

SECTION 10

SEATS

INDEX

Subject	Page	Subject	Page
Introduction	10-2	Arm Rest Assembly - Notch Down and Strato Seat Back	10-22
Front Seats - Full Width	10-2	Arm Rest Support - Notch Down and Strato Seat Back	10-22
Front Seat Assembly - Manually Operated	10-2	Foot Rest Assembly - Cadillac 68169 Styles	10-23
Description	10-2	Bucket Seats	10-23
Seat Assembly	10-3	Description	10-23
Adjuster Assembly	10-3	Manually Operated Bucket Seat Assembly	10-23
Front Seat Assembly - Power Operated (2, 4 and 6-Way)	10-3	Power Operated Horizontal or Four-Way Assembly	10-24
Description	10-3	Manually Operated Bucket Seat Adjuster	10-25
Seat Assembly	10-4	Power Operated Horizontal Adjuster	10-26
Adjuster Assembly	10-7	Power Operated Four-Way Adjuster	10-26
Two-Way Seat Adjuster Components -		Power Operated Four-Way Adjuster Components	10-27
"C" Body	10-8	Motor and Transmission Drive Belt and Pulleys	10-28
Electric Motor	10-8	Motor Assembly	10-28
Horizontal Gearnut	10-9	Transmission Assembly and Drive Cables	10-28
Horizontal Jackscrew	10-9	Disassembly and Assembly of Transmission	10-28
Plastic Slides	10-9	Adjuster Vertical Gearnut	10-29
Four-Way Seat Adjuster Components -		Adjuster Jackscrew	10-29
"A" Body	10-9	Adjuster Horizontal Actuator	10-29
Electric Motor	10-9	Torque Tube Assembly	10-29
Vertical Gearnut	10-10	Standard Bucket Seat Back - Two Door Styles Except Corvair	10-30
Horizontal Actuator	10-11	Standard Bucket Seat Back - Corvair	10-30
Jackscrew	10-12	Reclining Front Seat Back and Headrest	10-32
Horizontal and Vertical Drive Cables	10-12	Reclining Front Seat Back	10-32
Transmission	10-12	Description	10-32
Disassembly and Assembly of Transmission	10-12	Seat Back Assembly	10-32
Four-Way Seat Adjuster Components -		Positioning Unit	10-32
Buick "B, C & E" Body	10-13	Strato Seat Back Headrest	10-33
Electric Motor	10-13	Description	10-33
Vertical Gearnut	10-13	Support Guide Tube	10-33
Horizontal Actuator	10-14	Headrest Supports	10-33
Horizontal and Vertical Drive Cables	10-14	Rear Seat	10-34
Transmission	10-14	Rear Seat Cushion	10-34
Disassembly and Assembly of Transmission	10-15	Rear Seat Back - All Except Corvair	10-34
Six-Way Seat Adjuster Components -		Rear Seat Back Center Arm Rest and Curtain	10-34
"B, C & E" Body	10-15	Rear Seat Back Center Arm Rest Hanger Plate and Linkage	10-34
Electric Motor	10-15	Folding Rear Seat Back - Corvair	10-35
Horizontal Actuator	10-15	Folding Rear Seat Back Assembly	10-35
Front Vertical Gearnut	10-16	Folding Rear Seat Back Linkage	10-35
Rear Vertical Gearnut	10-16	Folding Rear Seat Back Filler Panel	10-35
Lower Channel and Plastic Slides	10-17	Station Wagon Folding Rear Seats and Floor Panels - "B" Body	10-35
Upper Channel	10-17	Description	10-35
Horizontal and Vertical Drive Cables	10-17	Rear Floor to Tail Gate Filler Panel Assembly 25-26000 Series	10-36
Transmission	10-17	Compartment Pan Side Filler Panel	10-37
Disassembly and Assembly of Transmission	10-18	Luggage Compartment Front and Rear Panel Assemblies - Two Seat Styles	10-37
Front Seat Back	10-18	Luggage Compartment Rear Panel - Two Seat Styles	10-37
Seat Back Assembly - Four Door with Standard Seat	10-18	Luggage Compartment Front and Rear Panel Hinge	10-38
Seat Back Assembly (Right or Left) - Two Door with Standard Seat	10-19	Folding Third Seat Cushion - Three Seat Styles	10-38
"Strato" Seat Back Assembly (Right or Left) - All Except 16639 Styles	10-19		
"Strato" Seat Back Assembly (Right or Left) - 16639 Styles	10-20		
Standard Seat Back Headrest	10-21		
Front Seat Center Arm Rest	10-21		
Arm Rest and Curtain - Standard Full Width Seat Back	10-21		
Arm Rest and Support - Standard Full Width Seat Back	10-21		
Arm Rest and Curtain - Notch Down and Strato Seat Back	10-22		

Subject	Page	Subject	Page
Folding Third Seat Cushion, Panel and Support - Three Seat Styles	10-38	Station Wagon Folding Rear Seats and Floor Panels - "A" Body "55 and 65" Styles	10-44
Folding Third Seat Back Trim - Three Seat Styles	10-38	Description	10-44
Folding Third Seat Back Panel - Three Seat Styles	10-39	Second Seat Assembly - Right or Left - "65" Styles	10-46
Compartment Floor Panel (At Kick-Up)	10-39	Second Seat Cushion - Right or Left - "65" Styles	10-46
Rear Floor Filler Panel	10-39	Second Seat Back Trim and Spring - Right or Left - "65" Styles	10-47
Second Seat Cushion (Full Width or Split Seat)	10-39	Second Seat Front Floor Pan Linkage - Right or Left - "65" Styles	10-47
Second Seat Back Trim (Full Width or Split Seat)	10-40	Second Seat Rear Floor Pan Linkage - Right or Left - "65" Styles	10-47
Second Seat Back Trim, Panel and Linkage (Full Width or Split Seat)	10-40	Second Seat Side Inner Linkage - Right or Left - "65" Styles	10-47
Second Seat Back Linkage (Full Width Both Sides; Split Seat-Outer Only)	10-41	Second Seat Side Outer Linkage - Right or Left "65" Styles	10-48
Second Seat Split Back Inner Linkage	10-41	Second Seat Back Lock - Right or Left - "65" Styles	10-48
Second Seat Back Catch - 25-26000 Styles	10-41	Second Seat Back Panel and Filler - Right or Left - "65" Styles	10-48
Luggage Compartment Lock Cylinder - 15-16000 Styles	10-42	Third Seat and Floor Panel - "65" Styles	10-49
Luggage Compartment Lock - 15-16000 Styles	10-42	Third Seat Cushion Trim - "65" Styles	10-50
Station Wagon Folding Rear Seats and Floor Panels - "A" Body Except 65" Styles	10-43	Third Seat Back Trim or Seat Back Panel - "65" Styles	10-50
Description	10-43	Luggage Compartment Cover Panel and Filler Panel - "65" Styles	10-50
Rear Compartment Floor Panel Covering - Styles with Rubber Mat	10-43	Seat Belts	10-50
Rear Compartment Floor Panel Covering - Styles with Vinyl Mat	10-43	Front Standard Seat Belts	10-50
Rear Compartment Floor Panel Covering - Styles with Floor Carpet	10-43	Front Deluxe Seat Belts with Bail Type Retractors	10-51
Rear Seat Cushion - Two Seat Styles	10-43	Description	10-51
Rear Seat Back Trim and Spring - Two Seat Styles	10-44	Deluxe Seat Belts	10-51
Rear Compartment Floor Panel (At Kick-Up) - Two Seat Styles	10-44	Bail Type Retractor	10-52
Rear Seat Back and Panel - Two Seat Styles	10-44	Front Deluxe Seat Belts with Floor Mounted Retractor and Cover	10-52
Rear Floor Filler Panel - Two Seat Styles	10-44	Description	10-52
		Outboard Seat Belts	10-52
		Inboard Seat Belts - Bucket Seats	10-53
		Rear Seat Belts	10-53

INTRODUCTION

In addition to the standard line full width seats for 1966, a new design "Strato" full width and bucket seat have been introduced this year. The new "Strato" seats are contoured to provide greater comfort and are thinner to provide additional leg room. A reclining seat back with head rest is available on the passengers side on some body

styles. The "Strato" head rest is also available on both the drivers and passengers side of "Strato" seats. All bucket seats, with the exception of Corvair use the new "Strato" design bucket seats. A standard seat back head rest is available for both the drivers and passengers side of the seat back.

FRONT SEATS—FULL WIDTH

FRONT SEAT ASSEMBLY— MANUALLY OPERATED

Description

The conventional full width manually operated seat assembly incorporates manually operated seat adjusters to provide fore and aft movement of the

seat. When the lever at the left seat adjuster is moved forward the seat adjusters unlock, permitting horizontal travel of the seat. When the seat is in the desired position, and the locking lever is released, the seat is locked.

All seat adjusters are secured to the floor pan by nuts installed on floor pan anchor plate studs or bolts installed into anchor nuts in the floor pan. (See Fig. 10-1 and Fig. 10-2).

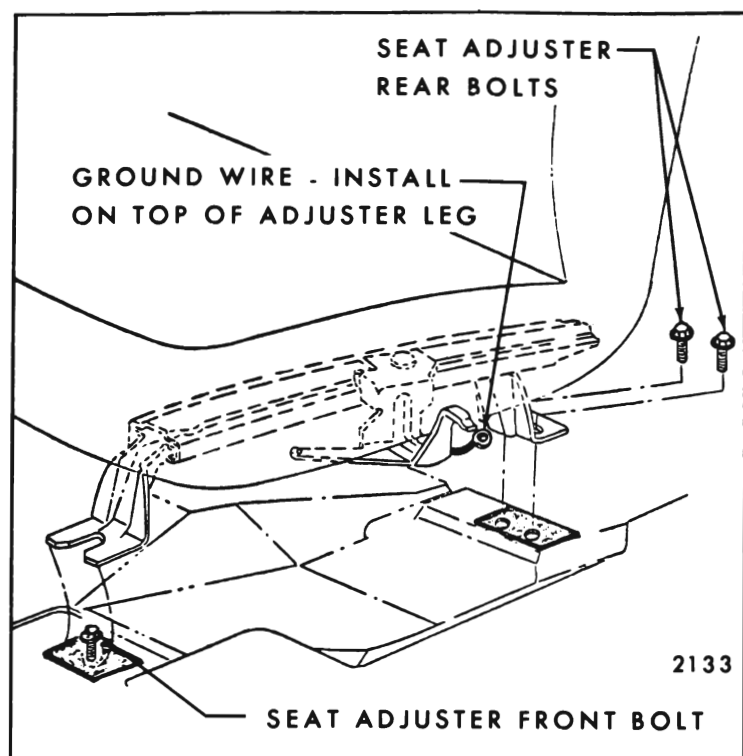

Fig. 10-1—Seat Adjuster Floor Pan Attachment -
"A, X & Z" Full Width Seat

Seat Assembly

Removal and Installation

1. Remove both driver and passenger inner seat belt floor pan attaching bolt.
2. Remove door sill plates and turn back floor mat or carpeting, where necessary, to expose seat adjuster-to-floor pan attaching nuts or bolts.
3. Operate seat to full forward position.
4. At rear of adjusters, remove adjuster-to-floor pan rear attaching nuts or bolts (Fig. 10-1 and Fig. 10-2).
5. Operate seat to full rearward position. On "A, X & Z" Body Styles loosen adjuster-to-floor pan front attaching bolts. Then with aid of a helper, slide seat assembly rearward until front legs of adjusters are disengaged from under front attaching bolts. Remove seat assembly from body.

On "B & C" Body Styles remove adjuster-to-floor pan front attaching bolts. On Styles with seat back cigar lighter tilt seat assembly rearward sufficiently to disconnect lighter feed wire. With aid of a helper, remove seat assembly from body.

6. To install seat assembly, reverse removal procedure. Where seat adjuster-to-floor pan

spacers were present reinstall spacers in same position.

NOTE: On "A, X & Z" Body Styles make certain front legs of adjusters are completely engaged under front attaching bolts before tightening bolts.

Check operation of seat assembly to full limits of travel.

Adjuster Assembly

Removal and Installation

1. Remove front seat assembly with adjusters attached, as previously described, and place upside down on a clean protected surface.
2. Remove seat adjuster assist spring from adjuster to be removed (Fig. 10-3).
3. If left adjuster is being replaced, remove adjuster control knob.
4. Squeeze hooked end of seat adjuster locking wire together and slide retaining spring back over hump in locking wire and remove locking wire from adjuster.
5. Remove adjuster-to-seat bottom frame front and rear attaching bolts (Fig. 10-3) and remove seat adjuster from seat.
6. To install, reverse removal procedure.

NOTE: The right and left seat adjuster sliding mechanism should be in same relative position when attaching adjuster to seat bottom frame.

After installing adjusters to seat frame, check operation of adjusters. If adjusters do not lock or unlock satisfactorily when control handle on left adjuster is operated, disengage locking wire retainer from hole in seat bottom frame and engage retainer in one of adjacent holes to obtain proper tension in wire. (Fig. 10-3)

FRONT SEAT ASSEMBLY—POWER OPERATED TWO, FOUR OR SIX-WAY FULL WIDTH SEAT

Description

The seat adjusters are actuated by a 12 volt, reversible, shunt wound motor with a built in circuit breaker. The motor is energized by a toggle-type control switch installed in the left seat side panel or in the left door arm rest.

On four-way and six way power operated seats the seat operating mechanism incorporates a transmission assembly which incorporates solenoids

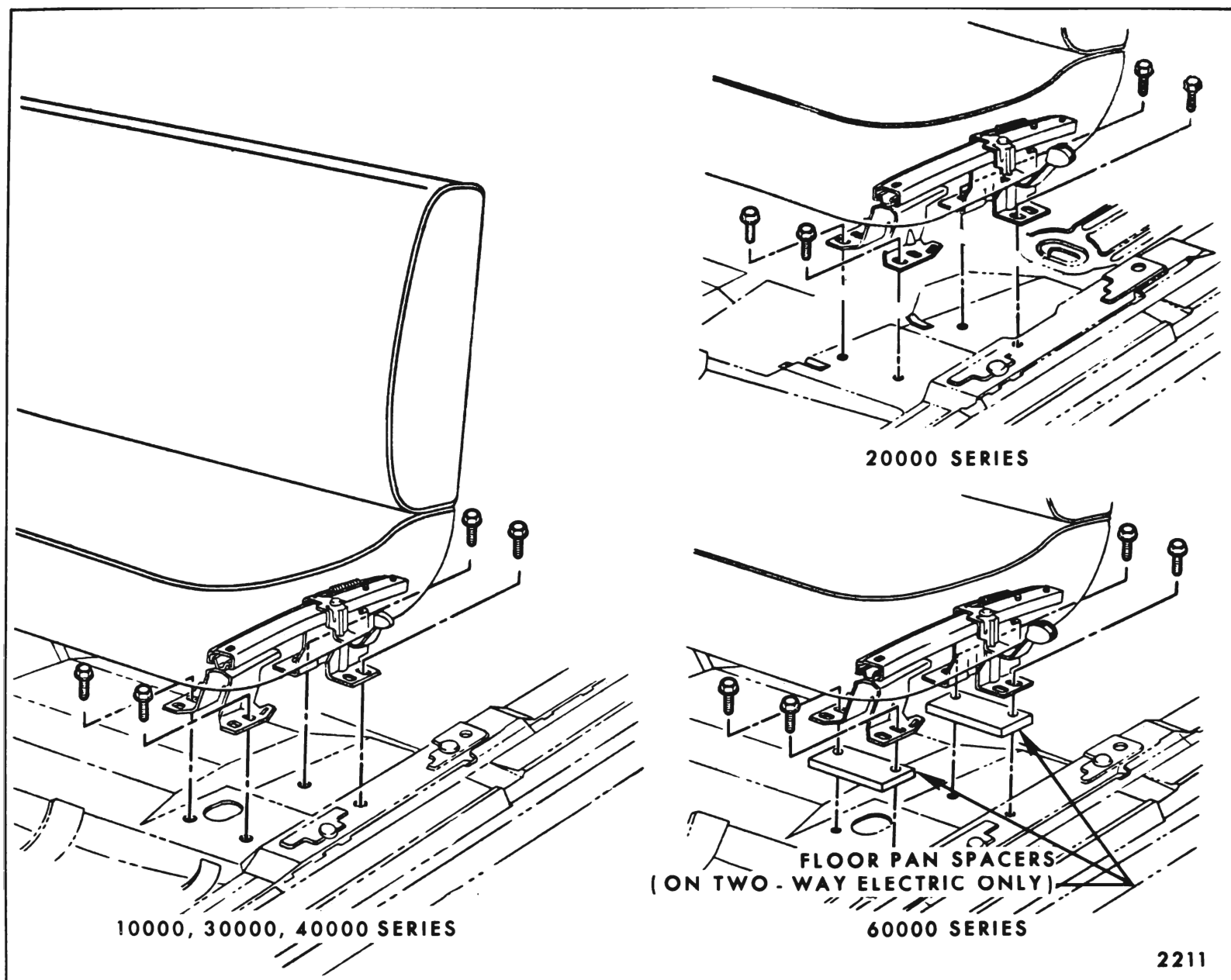

Fig. 10-2—Seat Adjuster Floor Pan Attachment - "B & C" Full Width Seat

and drive cables to the seat adjusters. On the four-way seat one solenoid controls the horizontal movement of the seat while the second solenoid controls the vertical movement of the seat. On the six-way seat one solenoid controls the vertical movement of the front of the seat, the second solenoid controls the horizontal movement of the seat and the third solenoid controls the vertical movement of the rear of the seat. When the control switch is actuated, the motor and one of the solenoids are energized simultaneously. Then the solenoid plunger engages with the driving gear dog. The driving gear rotates the drive cables and operates both adjusters. When the adjusters reach their limit of travel, the drive cables stop their rotating action and torque is absorbed by the rubber coupler connecting the motor and transmission. When the control switch is released, a return spring returns the solenoid plunger to its original position disengaging it from the driving gear dog.

Seat Assembly

Removal and Installation

1. Operate seat to full forward position. On four-way or six-way power seats operate seat to full up position.
2. Remove both driver and passenger inner seat belt floor pan attaching bolt. Remove seat cushion side panels where present. Where seat adjuster track covers are present carefully pry out track cover snap in retainers with a flat-bladed tool and remove track covers.
3. Where necessary, remove sill plates and turn back floor mat or carpeting to expose seat adjuster-to-floor pan attaching nuts or bolts.

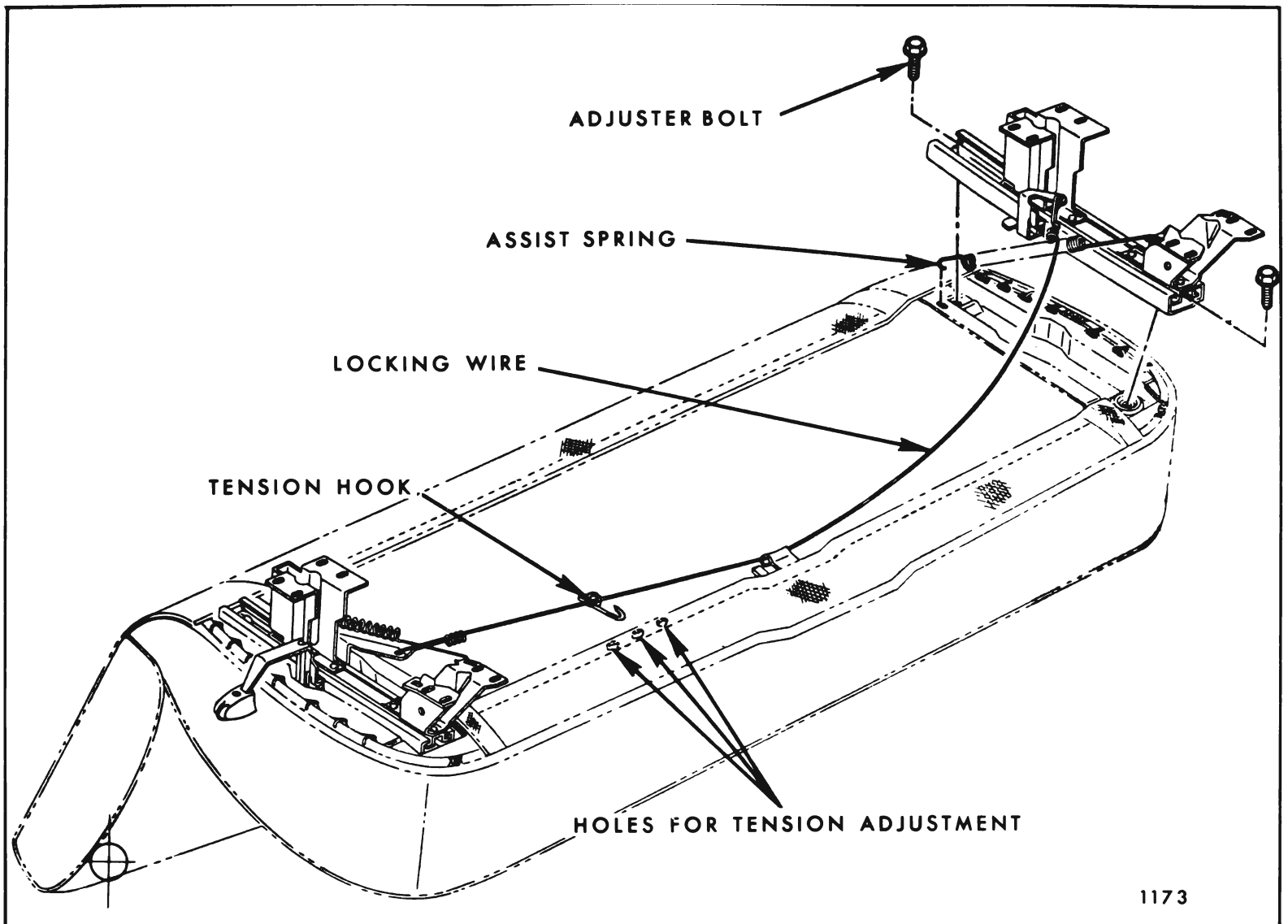

Fig. 10-3—Manually Operated Seat Adjuster Installation - "B & C" Shown "A, X & Z" Typical

4. Remove seat adjuster-to-floor pan rear attaching bolts (Fig. 10-1 or 10-2); then operate seat assembly to full rearward position.
 5. a. On "A" Body Styles with power operated seat adjusters, loosen adjuster-to-floor pan front attaching bolts (Fig. 10-1). With aid of helper, slide seat assembly rearward until front legs of adjusters are disengaged from under front attaching bolts. Tilt seat assembly rearward sufficiently to disconnect seat harness feed connector and detach harness from clip on floor pan (Fig. 10-4); then remove seat assembly from floor pan.
 - b. On "B & C" Body Styles remove adjuster-to-floor pan front attaching bolts (Fig. 10-2). Tilt seat assembly rearward sufficiently to disconnect seat harness feed connector and detach harness from clip on floor pan (Fig. 10-5 for Two-Way, Fig. 10-6 for Four-Way, Fig. 10-7 for Six-Way and Fig. 10-8 for Strato Six-Way). On styles with seat back cigar lighter, seat back courtesy lamps or seat back vanity lamp disconnect electrical feed wire or wires. With aid of a helper remove seat assembly from body.
 6. To install seat assembly, reverse removal procedure. Where seat adjuster-to-floor pan spacers were present reinstall spacers in same position.
- NOTE:** On "A" Body Styles make certain front legs of adjusters are completely engaged under front attaching bolts before tightening. Also check that carpet retainers are installed under rear attaching bolts (Fig. 10-1) and that floor mat or carpet is properly positioned under retainers.
- Make sure ground wire is securely attached under left seat adjuster-to-floor pan rear attaching bolt. Check for proper operation of seat adjusters to limits of travel.
- IMPORTANT:** When installing seat assembly in body, seat adjusters should be parallel and "in phase" with each other. In the event the

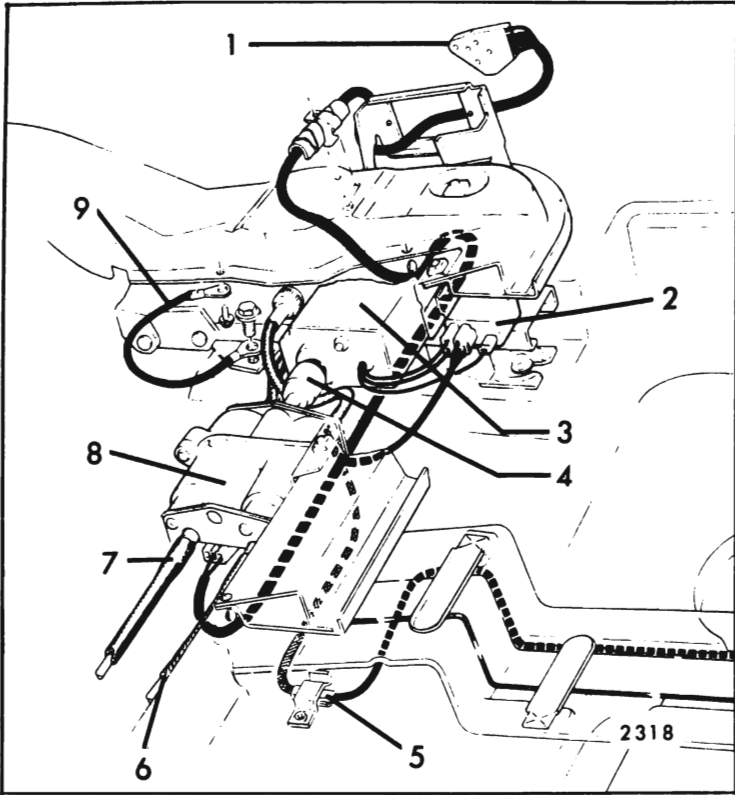

Fig. 10-4—Four-Way Full Width Seat Electric Wiring - "A" Styles

- | | |
|---------------------------|-----------------------------------|
| 1. Control Switch Block | 6. Vertical Drive Cable (Yellow) |
| 2. Motor Control Relay | 7. Horizontal Drive Cable (Black) |
| 3. Motor | 8. Transmission Assembly |
| 4. Rubber Coupler | 9. Seat Ground Wire |
| 5. Harness Feed Connector | |

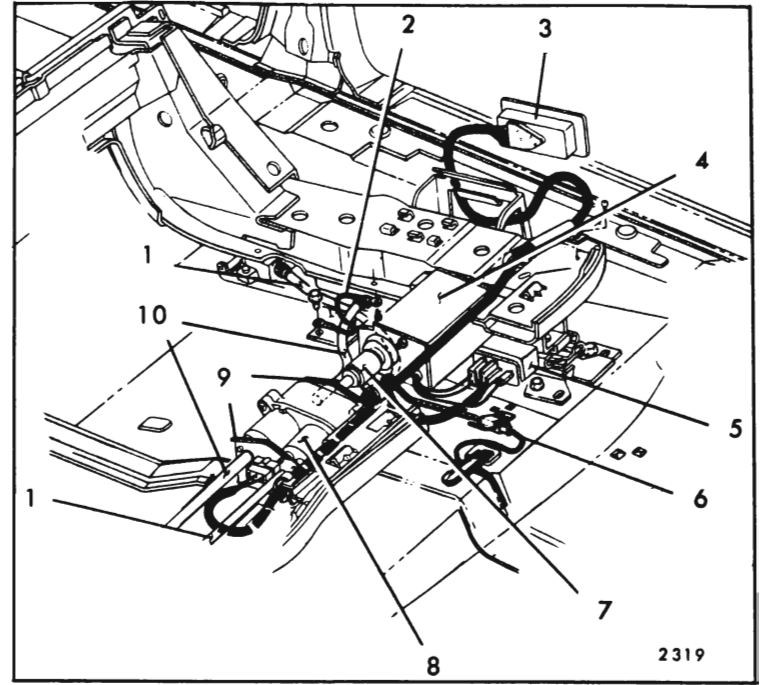

Fig. 10-6—Four-Way Full-Width Seat Electric Wiring - Buick "B, C & E" Styles

- | | |
|------------------------------------|--------------------------------------|
| 1. Vertical Control Cable (Yellow) | 6. Harness Feed Connector |
| 2. Ground Wire | 7. Rubber Coupler |
| 3. Control Switch | 8. Transmission Assembly |
| 4. Motor | 9. Transmission End Plates |
| 5. Motor Control Relay | 10. Horizontal Control Cable (Black) |

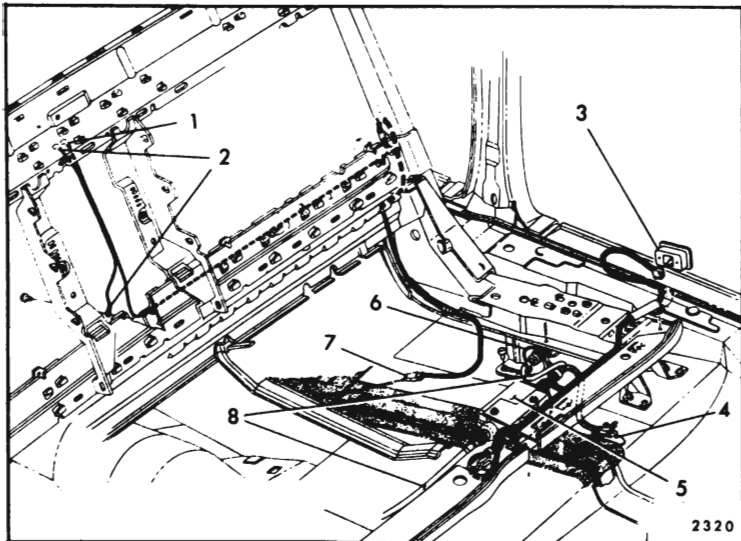

Fig. 10-5—Two-Way Full Width Seat Electric Wiring - "C & E" Styles

- | | |
|--|---|
| 1. Front Seat Back Switch Feed - White | 5. Motor |
| 2. Front Seat Back Switch Ground - Black | 6. Ground Wire |
| 3. Control Switch | 7. Front Seat Back Courtesy Lamp Feed Connector (Cadillac Only) |
| 4. Harness Feed Connector | 8. Horizontal Control Cable |

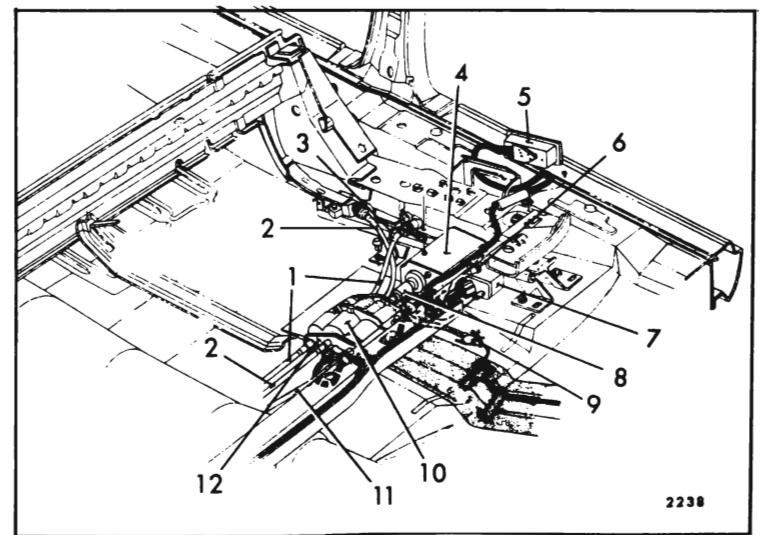

Fig. 10-7—Six-Way Full-Width Seat Electric Wiring - "B, C & E" Styles

- | | |
|--|--|
| 1. Horizontal Control Cable (Black) | 7. Motor Control Relay |
| 2. Rear Vertical Control Cable (Blue) | 8. Rubber Coupler |
| 3. Ground Wire | 9. Harness Feed Connector |
| 4. Motor | 10. Transmission and Solenoid Assembly |
| 5. Control Switch | 11. Front Vertical Control Cable (Yellow) - Right Side |
| 6. Front Vertical Control Cable (Yellow) - Left Side | 12. Transmission End Plate |

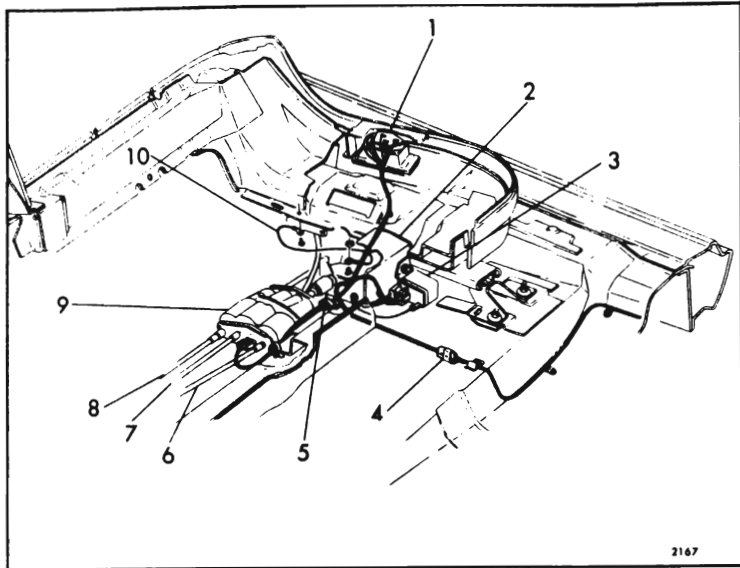

Fig. 10-8—"Strato" Six-Way Full-Width Seat Electric Wiring

- | | |
|--|---------------------------------------|
| 1. Control Cable | 7. Rear Vertical Control Cable (Blue) |
| 2. Motor | 8. Horizontal Control Cable (Black) |
| 3. Motor Control Relay | 9. Transmission Assembly |
| 4. Harness Feed Connector | 10. Ground Wire |
| 5. Rubber Coupler | |
| 6. Front Vertical Control Cable (Yellow) | |

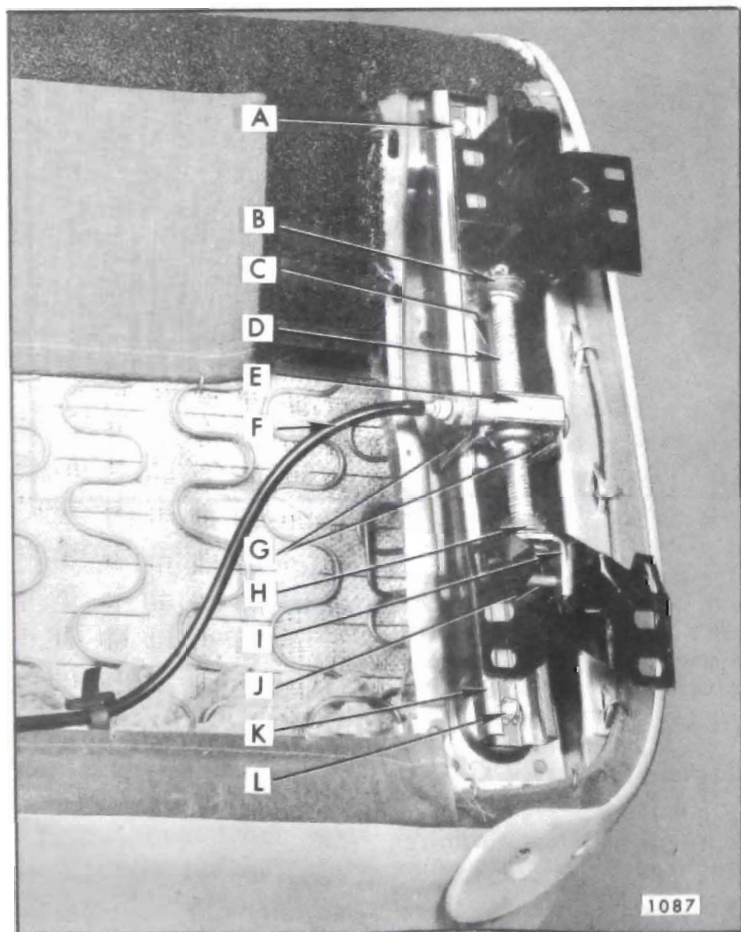

Fig. 10-9—Horizontal Power Adjuster - "C & E" Styles

- | | |
|----------------------------|----------------------------|
| A. Adjuster Attaching Bolt | G. Shoulder Bolts |
| B. Rear Stop | H. Front Stop |
| C. Adjuster Lower Channel | I. Stop Bracket |
| D. Jackscrew | J. Cross Pin |
| E. Gearnut | K. Adjuster Upper Channel |
| F. Drive Cable | L. Adjuster Attaching Bolt |

adjusters are "out of phase" (this is, one adjuster reaches its maximum horizontal or vertical travel in a given direction before the other adjuster), proceed as follows:

- a. Horizontal Travel - Operate seat control switch until one adjuster reaches full forward position. Detach horizontal drive cable from adjuster which has reached full forward position. Operate seat forward until other adjuster reaches full forward position; then, connect horizontal drive cable and check horizontal travel of seat.
- b. Front or Rear Vertical Travel - Operate seat control switch until one adjuster has reached the fully raised position at both front and rear vertical travel limits. Disconnect both front and rear vertical drive cables from adjuster which has reached the fully raised position. Operate seat control switch until other adjuster reaches the fully raised position at both front and rear vertical travel limits; then, connect previously removed front and rear vertical drive cables. Check vertical travel by operating adjusters through one or two complete cycles. The above operation may be repeated on an "as required" basis if adjusters do not appear to be "in phase" after test cycle.

Adjuster Assembly

Removal and Installation

1. Operate seat to a midway horizontal position; on four-way and six-way seats also operate seat to fully raised position.
2. Remove front seat assembly with adjusters attached, as previously described, and place upside down on a clean protected surface.
3. Detach power drive cables from gear nuts to adjuster to be removed (Fig. 10-9, 10-10, 10-11 and 10-12).
4. Remove adjuster-to-seat bottom frame front and rear attaching bolts and remove adjuster from seat assembly (Fig. 10-9, 10-10, 10-11 and 10-12).
5. To install seat adjuster assembly, reverse removal procedure. On seats with adjuster track covers, make sure track cover supports are installed between adjuster and seat frame (Fig. 10-10, 10-12 and 10-11). Check operation of seat adjusters and make sure adjusters are

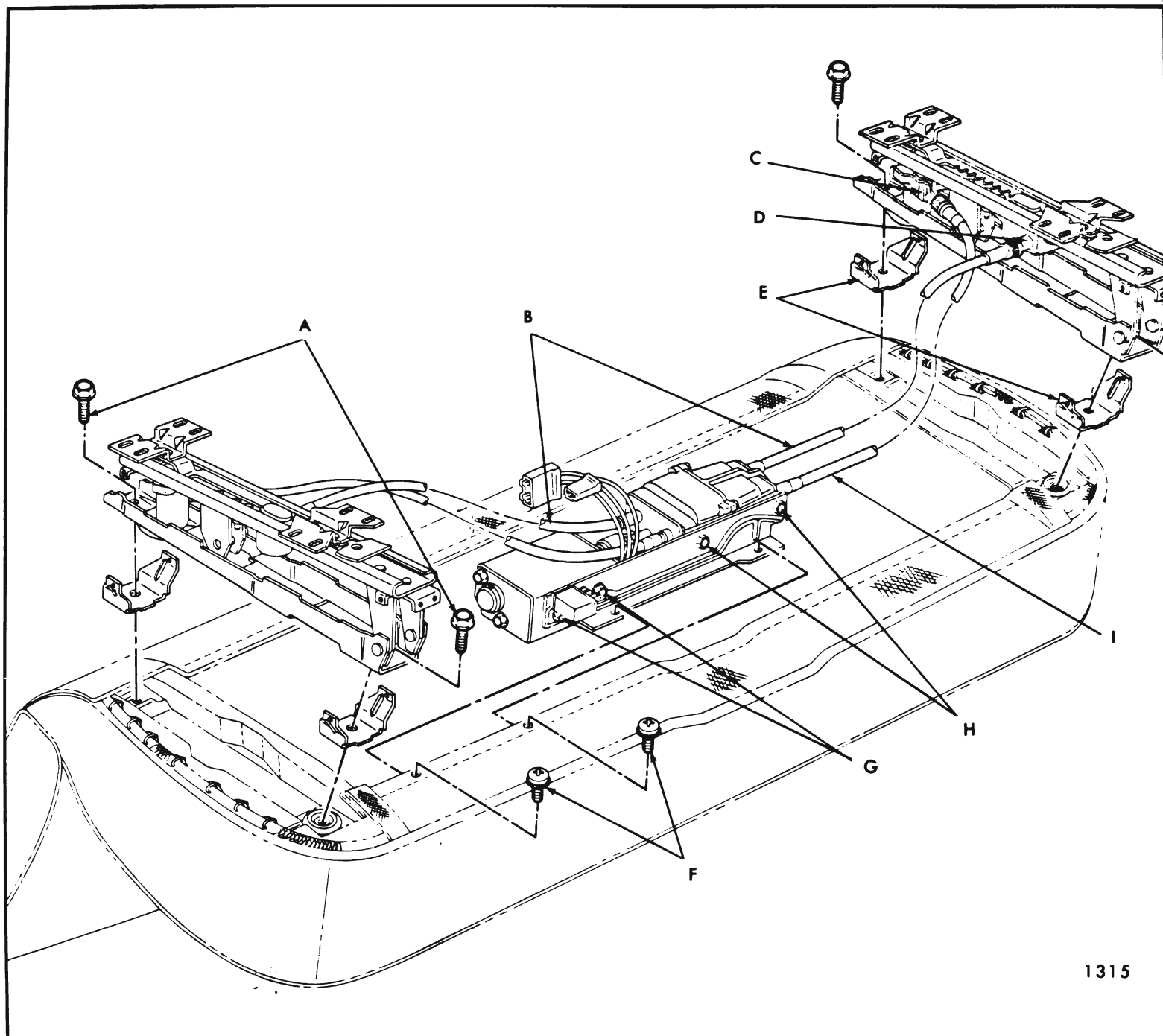

Fig. 10-10—Front Seat Assembly - Four-Way Tilt - Buick "B, C & E" Styles

A. Adjuster-to-Seat Attaching Bolts
 B. Horizontal Cables - Black
 C. Vertical Gearnut

D. Horizontal Actuator
 E. Track Cover Supports
 F. Motor and Transmission Support Attaching Screws

G. Motor Attaching Screws
 H. Transmission Attaching Screws
 I. Rear Vertical Cables - Blue

“in phase” before installing assembly into body (See Step 6 under “Front Seat Assembly - Removal and Installation”).

TWO-WAY SEAT ADJUSTER MAJOR COMPONENTS—“C” BODY FULL WIDTH SEATS

The following service procedures cover replacement of the major component parts of the power operated two-way seat adjusters used on “C” body full width seats.

Electric Motor—“C” Body

Removal and Installation

1. Remove front seat assembly as previously described and place upside down on a clean protected surface.
2. Disconnect both power drive cables from actuator motor.
3. Remove screws that secure actuator motor support bracket to seat bottom frame and

remove actuator motor with attached support bracket from seat assembly.

4. Disconnect feed wire harness from actuator motor (Fig. 10-5).
5. Remove screws securing motor to motor support bracket.
6. To install, reverse removal procedure. Check for proper seat operation to extreme limit of fore and aft travel.

Horizontal Gearnut Assembly—"C" Body

Removal and Installation

1. Remove front seat assembly with attached adjusters and place upside down on a clean, protected surface.
2. Detach power drive cable from gearnut to be removed.
3. Using a "clutch" type screwdriver or other suitable tool, remove two shoulder bolts securing gearnut to upper slide portion of seat adjuster (Fig. 10-9).
4. Rotate jackscrew assembly upward sufficiently to gain access to cotter pin at rear of jackscrew assembly.
5. Remove cotter pin, washer and rubber bumper from rear end of jackscrew; then, remove gearnut from jackscrew.
6. To install, reverse removal procedure. Prior to installing seat assembly in body, be sure adjusters are "in phase". See step 6 under "Front Seat Assembly - Removal and Installation".

Horizontal Jackscrew—"C" Body

Removal and Installation

1. Remove front seat assembly with attached adjusters and place upside down on a clean, protected surface.
2. Detach power drive cable from gearnut and jackscrew assembly to be removed.
3. Using a suitable tool (preferably a "clutch" type screwdriver) remove two shoulder bolts securing gearnut to upper slide portion of seat adjuster assembly (Fig. 10-9).

4. Remove retainer that secures stop bracket crosspin to adjuster front pedestal and remove crosspin (Fig. 10-9).
5. Remove jackscrew assembly from seat adjuster.
6. To install, reverse removal procedure.

NOTE: When replacing jackscrew assembly with new part, remove nut, washers, rubber bumper and stop bracket with inserted rubber grommet from front end of jackscrew, as well as gearnut and washers, rubber bumper and cotter pin from rear end of jackscrew and transfer to new jackscrew assembly.

Plastic Slides—"C" Body

Removal and Installation

1. Remove front seat adjuster to be serviced from front seat assembly. (See: Front Seat Adjuster - Two-Way Electric - Removal and Installation procedures).
2. Using a suitable tool (preferably a "clutch" type screwdriver), remove two shoulder bolts securing gearnut to upper channel of seat adjuster assembly (Fig. 10-9).
3. Slide lower track and support base portion of seat adjuster, with attached jackscrew and gearnut, forward until it disengages from upper channel assembly. The four plastic slides may now be disengaged from positioning slots on lower track.
4. To install, reverse removal procedure making sure that groove in plastic slide slips onto lower track with thinner section of slide protruding above surface of track.

FOUR-WAY SEAT ADJUSTER MAJOR COMPONENTS—"A" BODY FULL WIDTH SEATS

The following service procedures cover replacement of the major component parts of the power operated four-way seat adjusters used on the "A" body full width seats.

Electric Motor—"A" Body

Removal and Installation

1. Remove front seat assembly as previously described and place upside down on a clean protected surface.

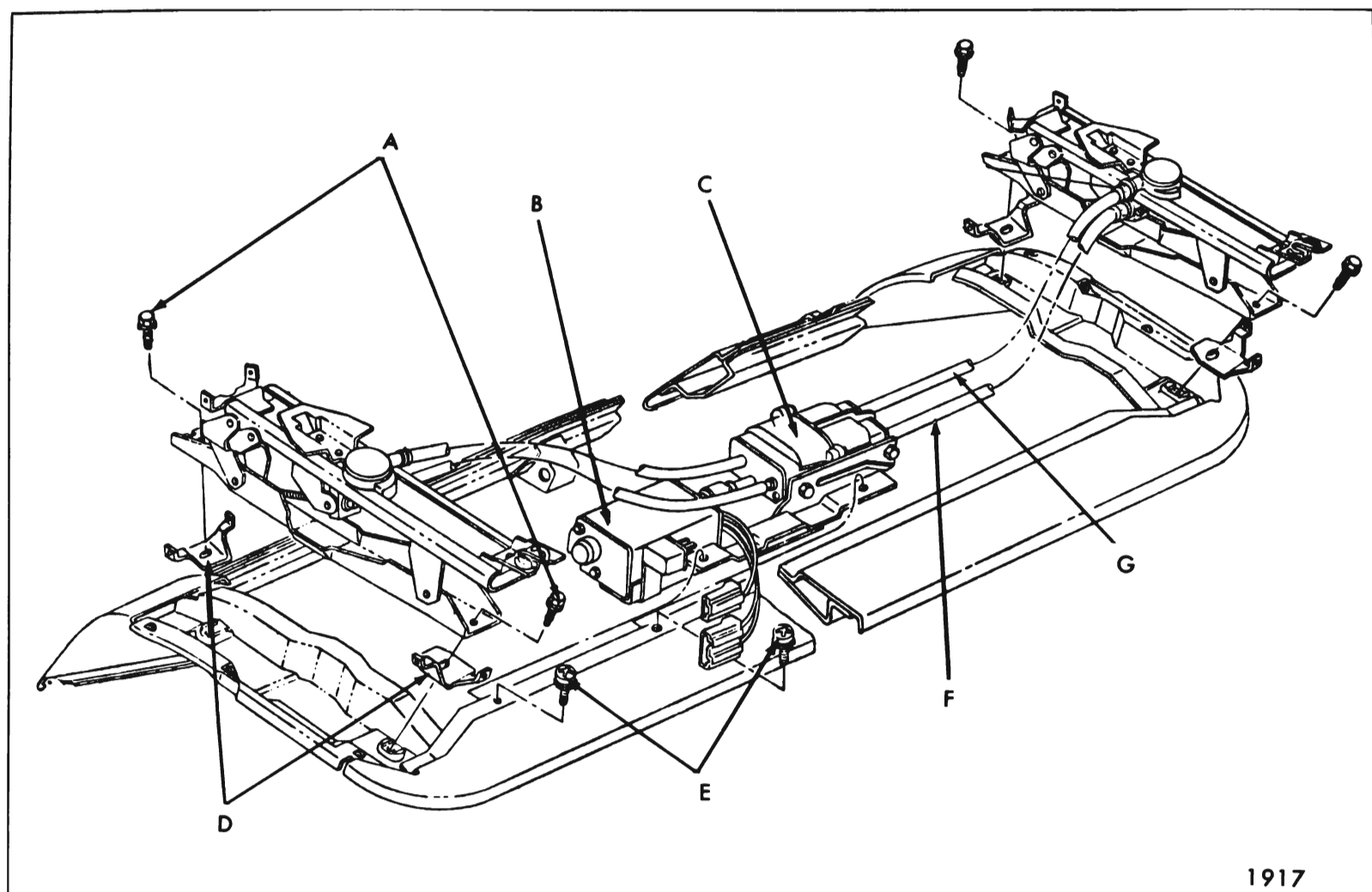

1917

Fig. 10-11—Front Seat Assembly - Four-Way Tilt - "A" Styles

A. Adjuster to Seat Frame
Attaching Bolts
B. Motor Assembly
C. Transmission Assembly

D. Track Cover Supports
E. Motor and Transmission
Support Attaching
Screws

F. Vertical Cable (Yellow)
G. Horizontal Cable (Black)

2. Disconnect wire harness from motor relay assembly.
3. Remove screws securing motor and transmission support to seat bottom frame. (Fig. 10-11)
4. Remove motor-to-motor support attaching screws and remove motor assembly from support.
5. To install, reverse removal procedure making sure rubber coupler is properly engaged at both motor and transmission ends. Check operation of seat to full limits of travel.

2. Remove front seat assembly from body as previously described and place upside down on a clean protected surface.
3. Detach vertical gearnut drive cable from other adjuster.
4. Using a clutch type screwdriver or other suitable tool, remove shoulder screws securing linkage to vertical gearnut being replaced (Fig. 10-13).
5. If right adjuster gearnut is being replaced, at front of jackscrew, remove double nut that acts as a jackscrew "down" stop.
6. Using a portable power source to energize the motor, actuate vertical gearnut until gearnut is disengaged from jackscrew.

Vertical Gearnut—"A" Body

Removal and Installation

1. Operate seat assembly to fully raised and mid-way position.

NOTE: It may be necessary to manually raise or lower upper rear portion of adjuster to gain clearance for removal of gearnut.

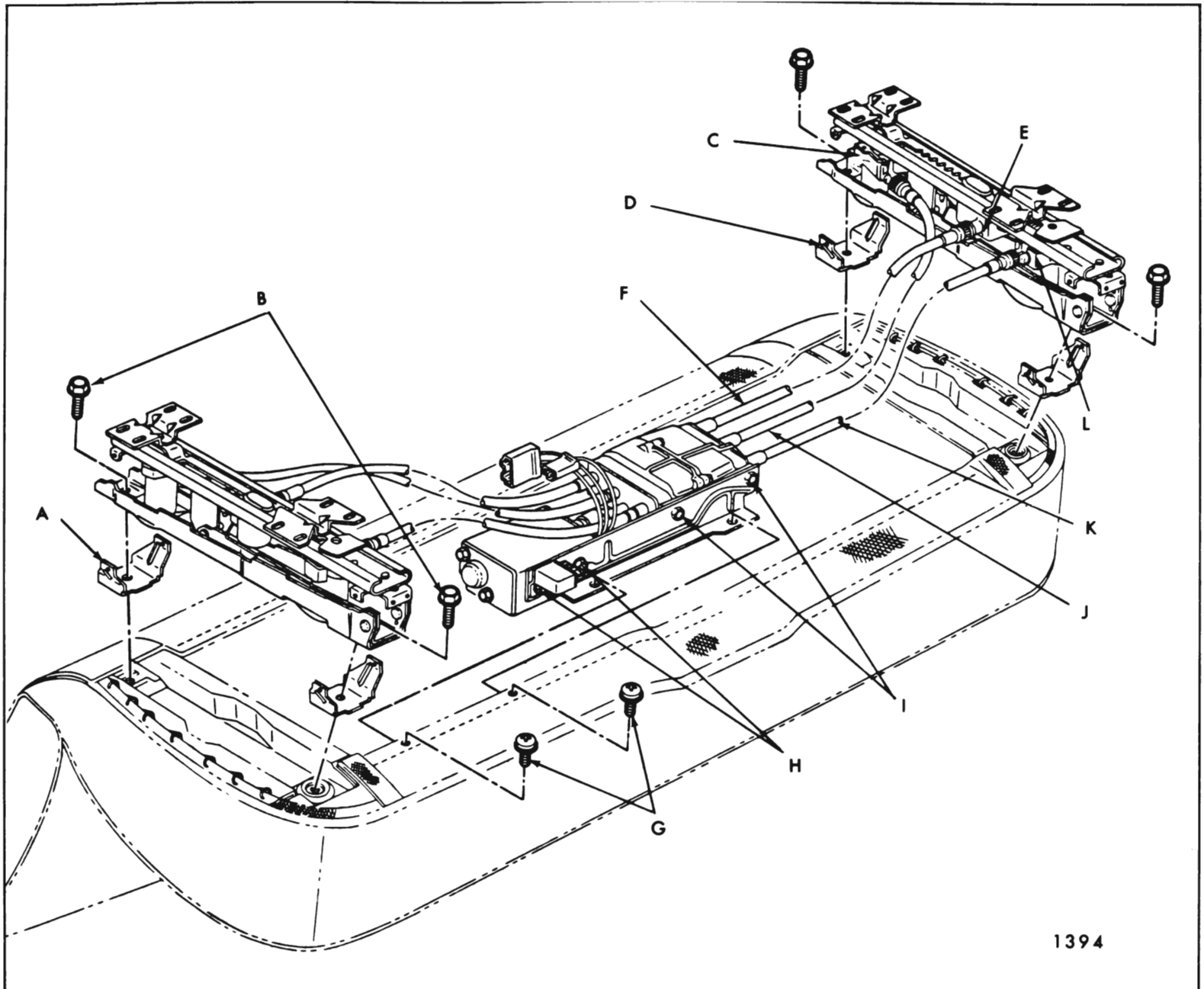

Fig. 10-12—Front Seat Assembly - Six-Way - "B & C" Styles

- | | | |
|--------------------------------------|--|-----------------------------------|
| A. Track Cover Support | E. Horizontal Actuator | H. Motor Attaching Screws |
| B. Adjuster-to-Seat Attaching Screws | F. Horizontal Cables - Black | I. Transmission Attaching Screws |
| C. Rear Vertical Gearnut | G. Motor and Transmission Support Attaching Screws | J. Rear Vertical Cables - Blue |
| D. Track Cover Support | | K. Front Vertical Cables - Yellow |
| | | L. Front Vertical Gearnut |

7. Disconnect drive cable from gearnut.
 8. To install, reverse removal procedure.
- NOTE:** Check operation of seat adjusters and make sure adjusters are "in phase". See step 6 under "Front Seat Assembly - Removal and Installation".
2. Disconnect drive cable from horizontal actuator.
 3. Remove screws securing horizontal actuator assembly to adjuster lower track; then remove actuator from adjuster assembly (Fig. 10-13).
 4. To install, reverse removal procedure.

NOTE: When installing horizontal actuator, adjust actuator so that drive gear is fully engaged with teeth on lower channel. When horizontal actuator attaching screws are tightened, there should be no free motion between upper and lower channels. Readjust actuator "as required" until all free motion between

Horizontal Actuator—"A" Body

Removal and Installation

1. Remove adjuster vertical gearnut as previously described.

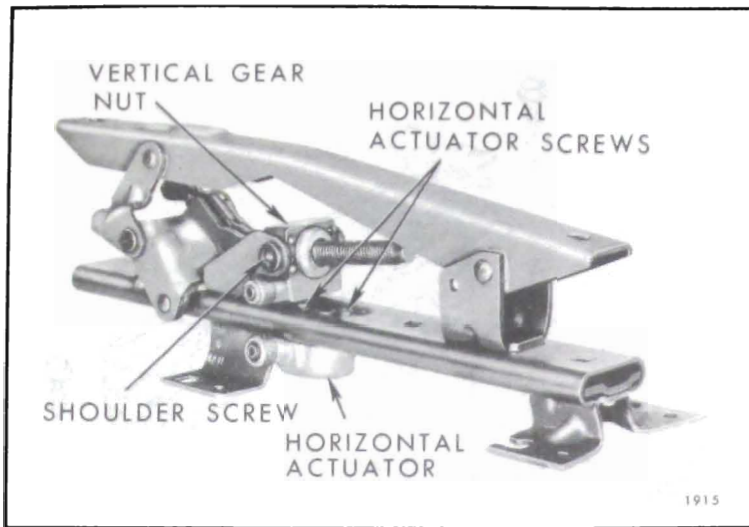

Fig. 10-13—Four-Way Seat Adjuster - "A" Styles

channels has been removed. Check operation of seat adjusters and make sure adjusters are "in phase". See step 6 under "Front Seat Assembly - Removal and Installation".

Jackscrew—"A" Body

Removal and Installation

1. Remove adjuster vertical gearnut as previously described.
2. Remove seat adjuster-to-seat bottom frame front and rear attaching bolts on side affected (Fig. 10-11).
3. As a bench operation, remove jackscrew-to-adjuster linkage attaching rivet and remove jackscrew from adjuster assembly (Fig. 10-14).

NOTE: It may be necessary to manually raise or lower upper rear portion of adjuster to gain access to jackscrew attaching rivet.

4. To install, reverse removal procedure. Check operation of seat adjusters and make sure adjusters are "in phase". See step 6 under "Front Seat Assembly - Removal and Installation".

Horizontal and Vertical Drive Cables—"A" Body

Removal and Installation

1. Remove front seat assembly from body with attached adjusters, motor and transmission and place upside down on a clean protected surface.

2. Detach both horizontal and vertical cables from seat adjuster.
3. Remove screws securing horizontal and vertical cable end plate on side of transmission from which cables are being removed and remove cables from seat assembly (Fig. 10-4).
4. Disengage cable to be replaced from end plate.
5. To install cables, reverse removal procedure. Check operation of seat to full limits of travel.

Transmission—"A" Body

Removal and Installation

1. Remove front seat assembly from body with attached adjusters, motor and transmission and place upside down on a clean protected surface.
2. Disconnect wire harness connector from transmission (Fig. 10-4).
3. Remove screws securing horizontal and vertical cable end plate on both sides of transmission and detach cables from transmission.
4. Remove transmission to support attaching bolts; then, disengage transmission from rubber coupler and remove transmission from seat assembly.
5. To install, reverse removal procedure.

Disassembly and Assembly of Transmission

1. Remove front seat adjuster transmission from seat assembly.

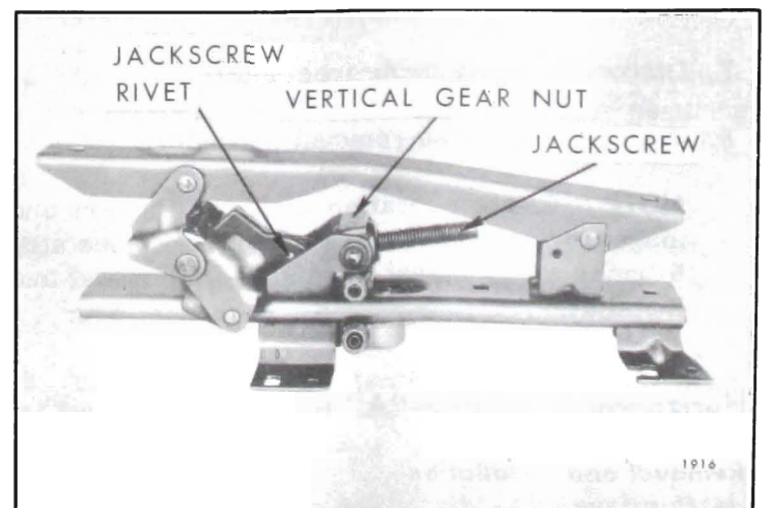

Fig. 10-14—Four-Way Seat Adjuster - "A" Styles

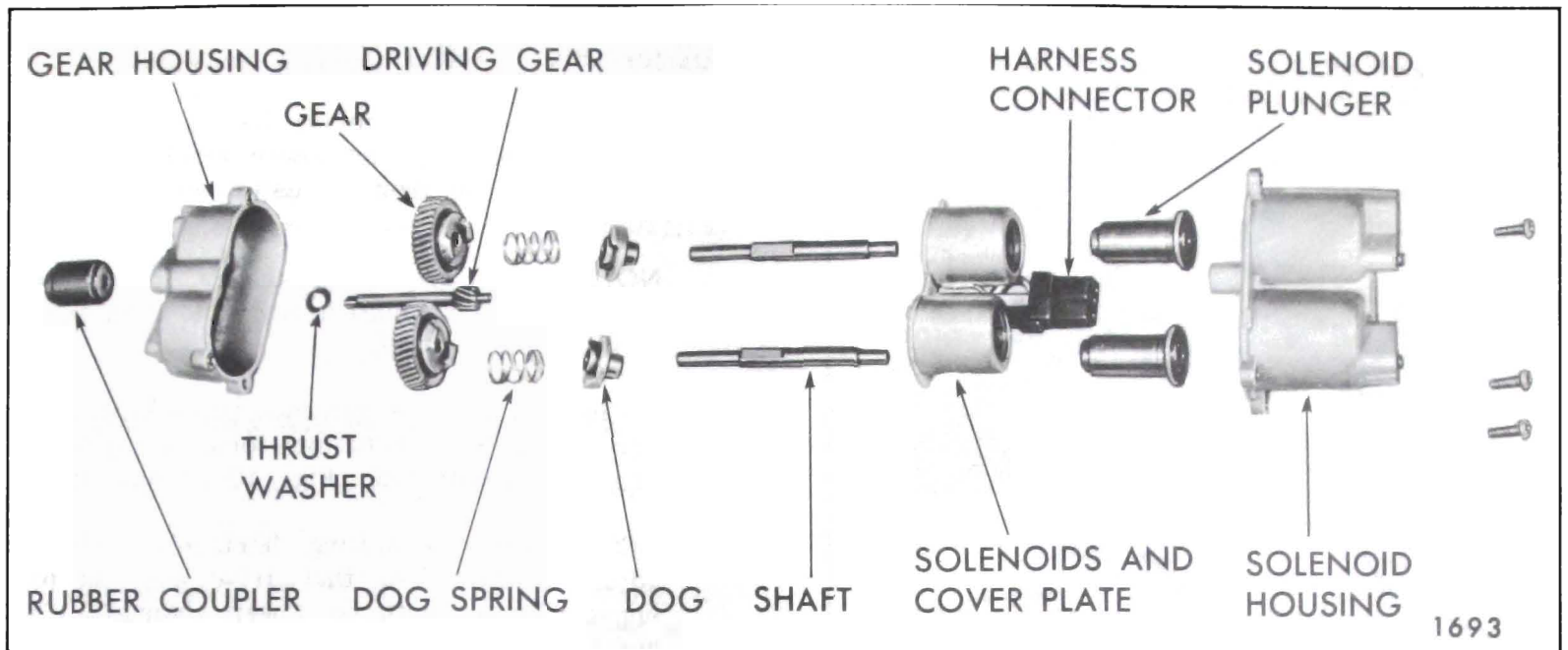

Fig. 10-15—Four-Way Seat Adjuster Transmission

- Remove screws securing gear and solenoid housings together; then, carefully separate housings and remove component parts of transmission assembly (Fig. 10-15).
- To assemble transmission, reverse removal procedure.

IMPORTANT: Prior to or during installation, lubricate frictional surfaces of driving gear thrust washer, gears, dog washers, shaft and solenoid plungers with "Lubriplate" (630AAW) or equivalent.

FOUR-WAY SEAT ADJUSTER MAJOR COMPONENTS—BUICK "B-C & E" FULL WIDTH FOUR-WAY POWER SEAT

The following service procedures cover replacement of the major component parts of the power operated four-way seat adjusters used on the Buick "B-C & E" body full width seats.

Electric Motor—Buick "B-C & E" Body

Removal and Installation

- Remove front seat assembly, and place upside down on a clean protected surface.
- Disconnect wire harness from motor relay assembly (Fig. 10-6).
- Remove screws securing motor and transmission support to seat bottom frame (Fig. 10-10).

- Remove motor-to-support attaching screws and remove motor assembly from support.
- To install, reverse removal procedure making sure rubber coupler is properly engaged at both motor and transmission ends. Check that seat harness is properly secured to seat (Fig. 10-6). Check operation of seat to full limits of travel.

Vertical Gearnut—Buick "B-C & E" Body

Removal and Installation

- Operate seat to rearward position; then, remove front seat assembly and seat adjuster.

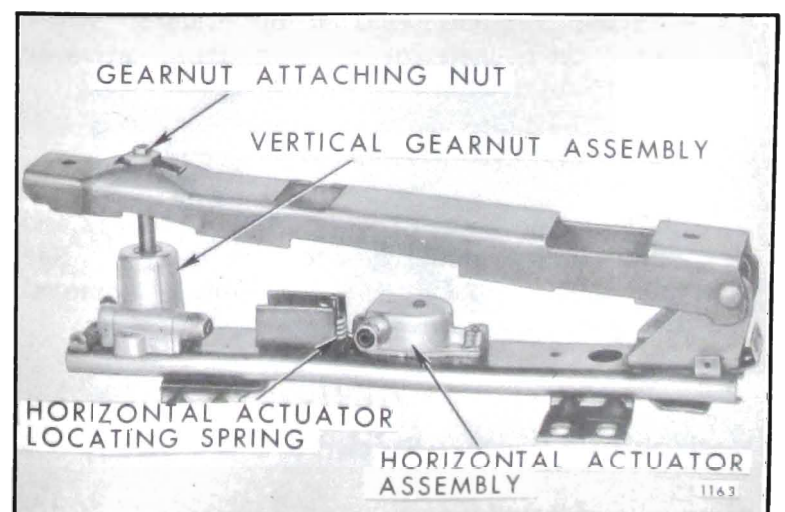

Fig. 10-16—Four-Way Seat Adjuster - Buick "B-C & E" Styles

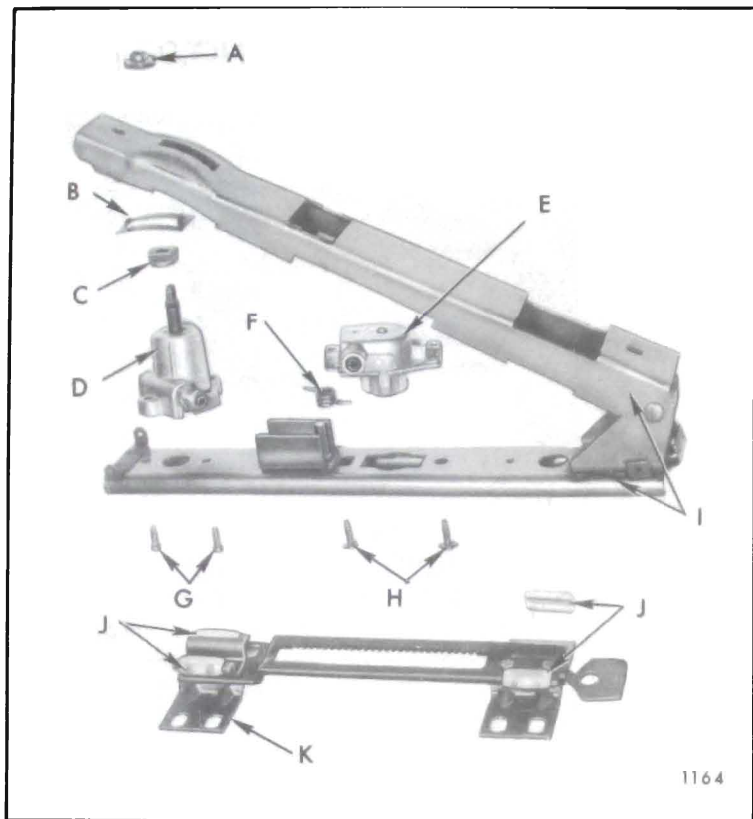

Fig. 10-17—Four-Way Seat Adjuster Components -
Buick "B-C & E" Styles

- | | |
|-----------------------------------|-------------------------------|
| A. Gearnut to Upper Attaching Nut | F. Locating Spring |
| B. Gearnut Tension Spring | G. Vertical Gearnut Screws |
| C. Gearnut Washer | H. Horizontal Actuator Screws |
| D. Vertical Gearnut Assembly | I. Upper Channel Assembly |
| E. Horizontal Actuator Assembly | J. Plastic Shoes |
| | K. Lower Channel |

- Remove vertical gearnut attaching nut at adjuster upper track (Fig. 10-16). Lift rear of channel upward and remove gearnut tension spring and washer (Fig. 10-17).
- Lay adjuster on its side and remove screws securing vertical gearnut to adjuster lower track; then, remove gearnut from adjuster (Fig. 10-16).
- To install, reverse removal procedure.

NOTE: Check operation of seat adjusters and make sure adjusters are "in phase". See step 6 under "Front Seat Assembly - Removal and Installation".

Horizontal Actuator—Buick "B-C & E" Body

Removal and Installation

- Remove front seat assembly and place upside down on a clean protected surface.

- Disconnect drive cable from horizontal actuator (Fig. 10-10).

- Remove screws securing horizontal actuator assembly to adjuster lower track; then, remove actuator from adjuster assembly (Fig. 10-17).

NOTE: It may be necessary to manually actuate the horizontal actuator to gain access to attaching screws.

- To install, reverse removal procedure. Make sure horizontal actuator locating spring is properly positioned (Fig. 10-16 and 10-17).

NOTE: When installing horizontal actuator, adjust actuator so that drive gear is fully engaged with teeth on lower channel. When horizontal actuator attaching screws are tightened, there should be no free motion between upper and lower channels. Readjust actuator "as required" until all free motion between channels has been removed. Check operation of seat adjusters and make sure adjusters are "in phase". See step 6 under "Front Seat Assembly - Removal and Installation".

Horizontal and Vertical Drive Cables— Buick "B-C & E" Body

Removal and Installation

- Remove front seat assembly, as previously described, and place upside down on a clean protected surface.
- Detach both horizontal and vertical cables from seat adjuster (See Fig. 10-10).
- Remove screws securing horizontal and vertical cable end plate on side of transmission from which cables are being removed and remove cables from seat assembly (See Fig. 10-6).
- Disengage cable to be replaced from end plate.
- To install cables, reverse removal procedure. Check operation of seat to full limits of travel.

Transmission—Buick "B-C & E" Body

Removal and Installation

- Remove front seat assembly, from body and place upside down on a clean protected surface.
- Disconnect wire harness connector from transmission (See Fig. 10-6).

3. Remove screws securing horizontal and vertical cable end plate on both sides of transmission and detach cables from transmission.
4. Remove transmission to support attaching bolts; then, disengage transmission from rubber coupler and remove transmission from seat assembly.
5. To install, reverse removal procedure.

5. To install, reverse removal procedure making sure rubber coupling is properly engaged at both motor and transmission. Check that seat harness is properly secured to seat (See Fig. 10-7). Check operation of seat to full limits of travel.

Disassembly and Assembly of Transmission

1. Remove front seat adjuster transmission from seat assembly.

IMPORTANT: Prior to or during installation, lubricate frictional surfaces of driving gear thrust washer, gears, dog washers, shaft and solenoid plungers with "Lubriplate" (630AAW) or equivalent.

2. Remove screws securing gear and solenoid housings together; then, carefully separate housings and remove component parts of transmission assembly (Fig. 10-15).
3. To assemble transmission, reverse removal procedure.

SIX-WAY SEAT ADJUSTER MAJOR COMPONENTS—"B-C & E" BODY FULL WIDTH SEATS

The following service procedures cover replacement of the major component parts of the power operated six-way seat adjusters used on the "B, C and E" body full width seats.

Electric Motor—"B-C & E" Body

Removal and Installation

1. Remove front seat assembly, as previously described, and place upside down on a clean protected surface.
2. Disconnect motor feed wires from motor control relay (See Fig. 10-7).
3. Remove motor support-to-seat frame attaching bolts.
4. Remove motor-to-support attaching bolts; then move motor assembly outboard (away from transmission) sufficiently to disengage motor from rubber coupling.

Horizontal Actuator—"B-C & E" Body

Removal and Installation

1. Remove seat assembly from body as previously described and place upside down on a clean protected surface.

NOTE: Horizontal Actuator is easily accessible with seat in mid-way or approximate center position.

2. Detach three power drive cables from adjuster to be removed.
3. Remove screws securing seat adjuster to seat bottom frame and remove adjuster from seat assembly.
4. At top of adjuster, remove front and rear vertical gearnut attaching nuts (Fig. 10-18).
5. Remove front vertical gearnut spring (Fig. 10-18).
6. Lift upward on adjuster upper track; then remove rear vertical gearnut spring (Fig. 10-18).
7. Lay adjuster on its side; then remove screws securing horizontal actuator to adjuster upper channel assembly and remove actuator from adjuster.

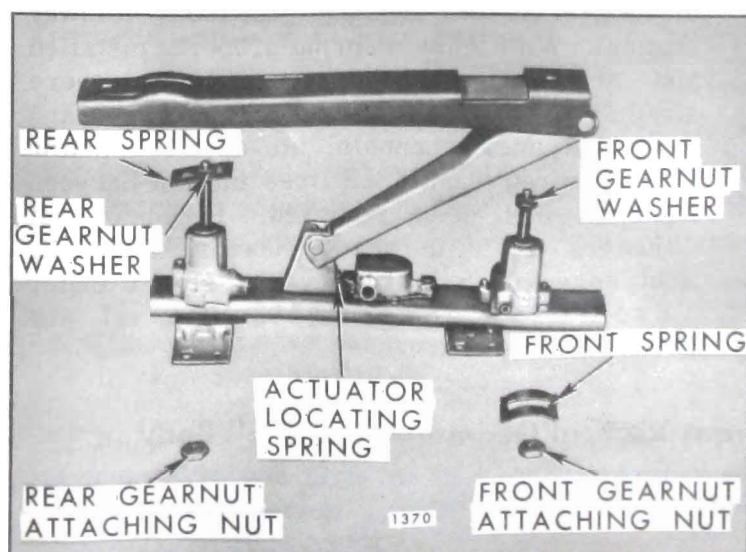

Fig. 10-18—Six-Way Seat Adjuster - "B & C" Styles

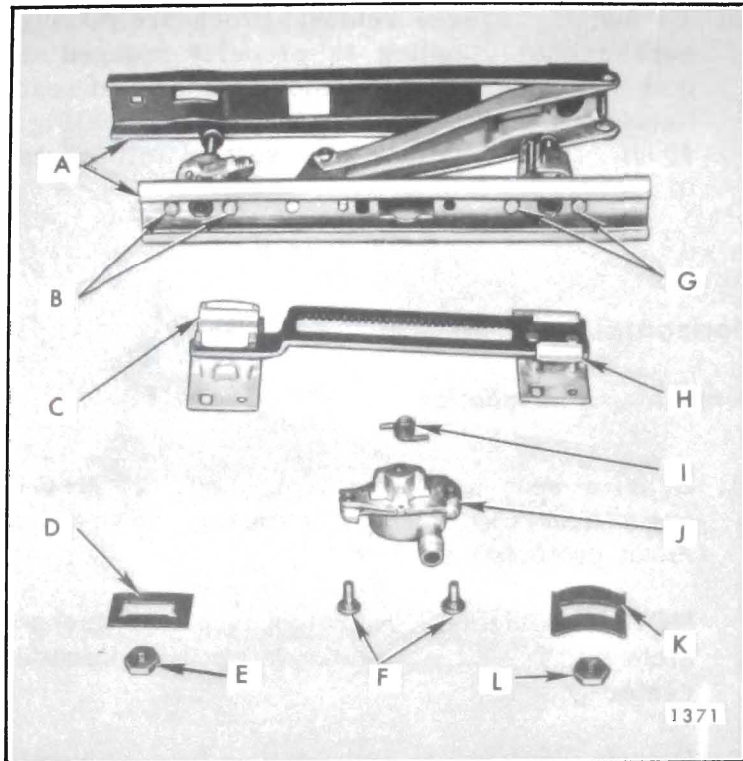

Fig. 10-19—Six-Way Seat Adjuster Components -
"B & C" Styles

- | | |
|---|--|
| A. Upper Channel Assembly | G. Front Vertical Gearnut Attaching Screws |
| B. Rear Vertical Gearnut Attaching Screws | H. Plastic Shoe |
| C. Lower Channel | I. Actuator Locating Spring |
| D. Rear Spring | J. Horizontal Actuator |
| E. Rear Gearnut Attaching Nut | K. Front Spring |
| F. Actuator Attaching Screws | L. Front Gearnut Attaching Screw |

IMPORTANT: Horizontal actuator is under tension from spring shown in Figure 10-18. When installing actuator, be sure actuator locating spring is properly engaged with actuator assembly.

- To install, reverse removal procedure. When installing horizontal actuator, be sure actuator drive gear is full engaged with teeth on lower channel. With tension spring properly installed and actuator attaching screws tight, there should be no free motion between upper and lower adjuster channels. Re-adjust actuator "as required" until all free motion between channels has been removed. Be sure seat adjusters are "in phase", before installing seat assembly into body. (See step 6 under "Front Seat Assembly - Removal and Installation").

Front Vertical Gearnut—"B-C & E" Body

Removal and Installation

- Operate seat to either full forward or full rearward position.

- Remove front seat assembly from body as previously described and place upside down on a clean protected surface.
- Detach three power drive cables from adjuster to be removed.
- Remove screws securing seat adjuster to seat bottom frame and remove adjuster from seat assembly.
- At top of adjuster, remove front vertical gearnut attaching nut.
- Remove front vertical gearnut spring (Fig. 10-18).
- Lay adjuster on its side and remove front vertical gearnut attaching screws (Fig. 10-19); then remove gearnut from adjuster.
- If front vertical gearnut is being replaced with a new part, transfer gearnut washer to new gearnut assembly (Fig. 10-18).
- To install, reverse removal procedure. Be sure adjusters are "in phase" before installing seat assembly into body. (See step 6 under "Front Seat Assembly - Removal and Installation").

Rear Vertical Gearnut—"B-C & E" Body

Removal and Installation

- Operate seat to full forward position.
- Remove front seat assembly from body as previously described and place upside down on a clean protected surface.
- Detach three power drive cables from adjuster to be removed.
- Remove screws securing seat adjuster to seat bottom frame and remove adjuster from seat assembly.
- At top of adjuster, remove rear vertical gearnut attaching nut (Fig. 10-18).
- Lift rear of channel upward and remove rear vertical gearnut spring (Fig. 10-18).
- Lay adjuster on its side and remove rear vertical gearnut attaching screws; then remove gearnut from adjuster (Fig. 10-19).
- If rear vertical gearnut is being replaced with a new part, transfer gearnut washer to new gearnut assembly (Fig. 10-18).

- To install, reverse removal procedure. Be sure rear gearnut spring is properly engaged under adjuster upper channel before tightening rear gearnut upper attaching nut. In addition, be sure adjusters are "in phase" prior to installing seat assembly into body. (See step 6 under "Front Seat Assembly - Removal and Installation").

Lower Channel and Plastic Slides— "B-C & E" Body

Removal and Installation

- Remove horizontal actuator as previously described.
- Slide seat adjuster lower channel from upper channel until lower channel is completely disengaged from upper channel. Remove plastic slides from lower channel.
- If lower channel is being replaced with a new part, transfer plastic slides to new part (Fig. 10-19).
- Apply "Lubriplate" (630AAW) or equivalent to track portion of upper channel, plastic slides and teeth on lower channel.
- To install, reverse removal procedure. Be sure adjusters are "in phase" before installing seat assembly into body. (See step 6 under "Front Seat Assembly - Removal and Installation").

Upper Channel—"B-C & E" Body

Removal and Installation

- Remove seat assembly from body and place upside down on a clean protected surface.
- Detach three power drive cables from adjuster to be removed.
- Remove screws securing seat adjuster to seat bottom frame and remove adjuster from seat assembly.
- Remove horizontal actuator from upper channel as previously described.
- Slide lower channel until it is completely disengaged from upper channel; then transfer lower channel to new upper channel.

NOTE: Be sure sliding surfaces of upper and lower channels are properly lubricated with "Lubriplate" (630AAW) or equivalent.

- Transfer front and rear gearnuts to new upper channel (Fig. 10-19).
- Install horizontal actuator and actuator locating spring to new upper channel.
- Install adjuster to seat bottom frame; then check all operations of adjusters. Be sure adjusters are "in phase" prior to installing seat assembly into body. (See step 6 under "Front Seat Assembly - Removal and Installation").
- Install seat assembly into body. Operate seat through several complete cycles to insure proper operation.

Horizontal and Vertical Drive Cables— "B-C & E" Body

Removal and Installation

- Remove front seat assembly from body with attached adjusters, motor and transmission and place upside down on a clean protected surface.
- Detach both horizontal and vertical cables from seat adjuster.
- Remove screws securing horizontal and vertical cable end plate on side of transmission from which cables are being removed and remove cables from seat assembly; then disengage cables from end plate.
- To install horizontal and vertical cables, reverse removal procedure. Make sure colored drive cables are installed to proper gearnuts and horizontal actuator as shown in Figure 10-12.

Transmission—"B-C & E" Body

Removal and Installation

- Remove front seat assembly from body with attached adjusters, motor and transmission and place upside down on a clean protected surface.
- Disconnect wire harness connector from transmission (See Fig. 10-7).
- Remove screws securing horizontal and vertical cable end plate on both sides of transmission and detach cables from transmission.
- Remove transmission to support attaching bolts; then disengage transmission from motor

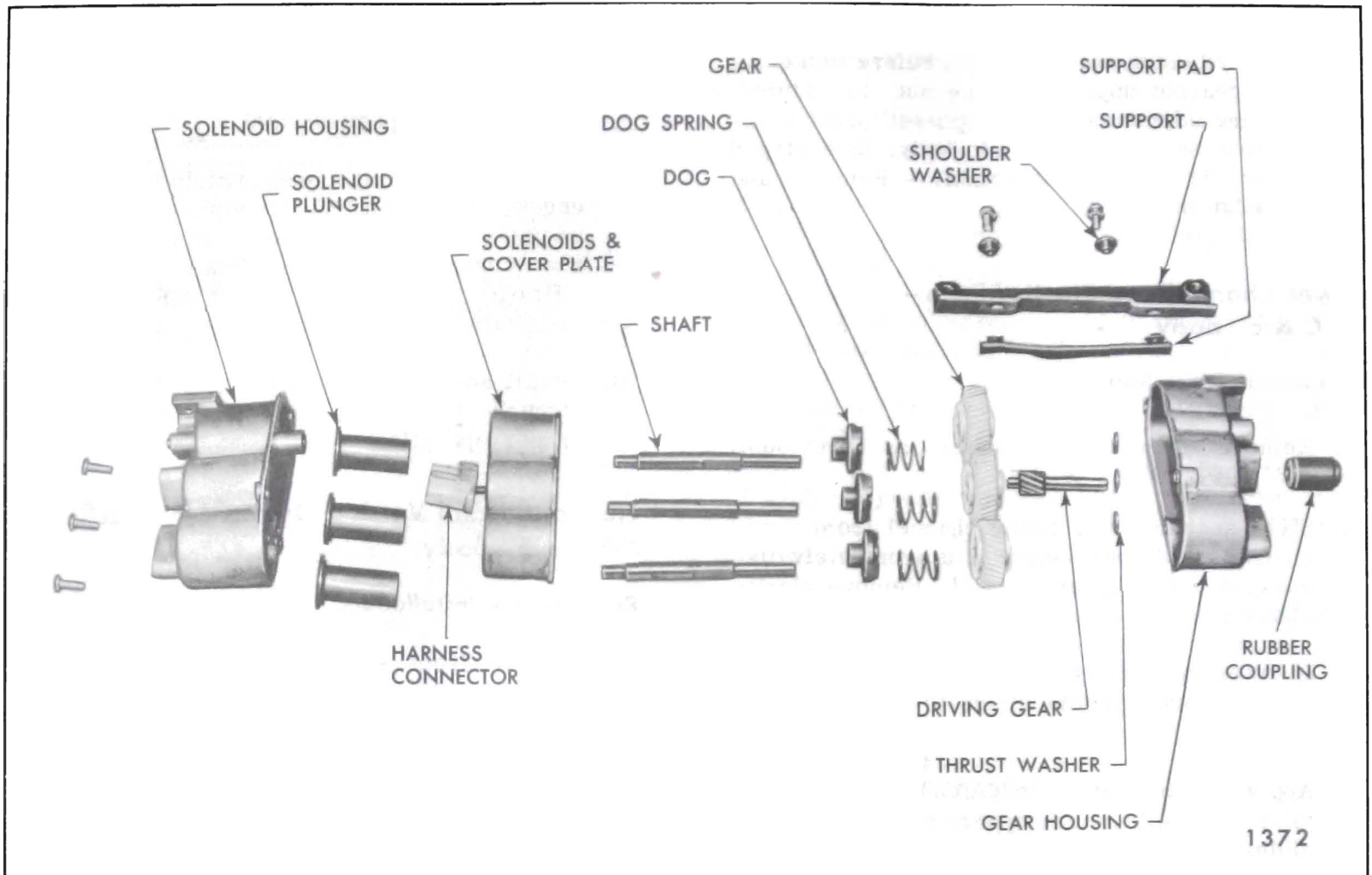

Fig. 10-20—Six-Way Seat Adjuster Transmission - "B & C" Style

drive coupling and remove transmission from seat assembly.

5. To install, reverse removal procedure. Make sure seat harness is properly secured to seat. (See Fig. 10-7).

Disassembly and Assembly of Transmission

1. Remove front seat adjuster transmission from seat assembly.
2. Remove screws securing gear housing to the solenoid housing; then, carefully separate housings and remove component parts of transmission assembly (Fig. 10-20).
3. To assemble transmission, reverse removal procedure.

IMPORTANT: Prior to or during installation, lubricate frictional surfaces of driving gear, thrust washer, large gears, dog washers, gear shafts and solenoid plungers with "Lubriplate" (630AAW) or equivalent.

FRONT SEAT BACK

Seat Back Assembly—Four Door Style with Standard Full Width Seat

Removal and Installation

1. Remove front seat assembly from body and place it upside down on a clean protected surface. Remove seat side panels, where present.
2. Remove hog rings securing lower edge of seat back trim to seat cushion springs.
3. On "A-X & Z" body full width front seats, raise lower edge of seat back trim, remove cardboard breakover foundation and bend out tabs on seat back frame securing seat cushion springs. Disengage springs from tabs.
4. At each end of seat, remove hog rings securing lower edge of seat back trim to seat bottom frame. Raise or turn back seat back trim to expose bolts securing seat back frame to seat cushion frame (Fig. 10-22). Where seat back lighter or courtesy light is present disconnect wire from seat cushion frame.

5. Place seat assembly in upright position. Then with a helper, holding seat back assembly, remove seat back attaching bolts on each side of seat and remove seat back assembly.
6. To install seat back assembly, reverse removal procedure.

Seat Back Assembly—(Right or Left)— Two Door Style with Standard Full Width Seat

Removal and Installation

1. a. On seat with seat cushion side panel, remove side panel and detach seat cushion trim sufficiently to expose outer hinge pin and retainer.
- b. On seats with outer hinge arm cover, remove screw securing cover and remove cover.
2. Using a flat bladed tool carefully remove retainer securing seat back outer arm to hinge pin.
3. Carefully disengage seat back outer arm from hinge pin; then, tilt seat back forward and upward to disengage seat back inner arm from hinge pin and remove seat back from body.
4. To install seat back assembly, reverse removal procedure making sure washers are installed over hinge pins prior to installing seat back. If outer retainer is damaged, install new retainer.

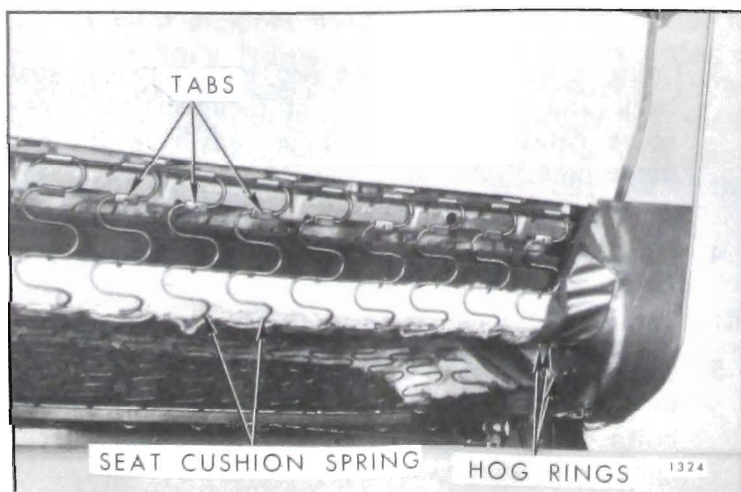

Fig. 10-21—Seat Cushion-to-Back Spring Attachment

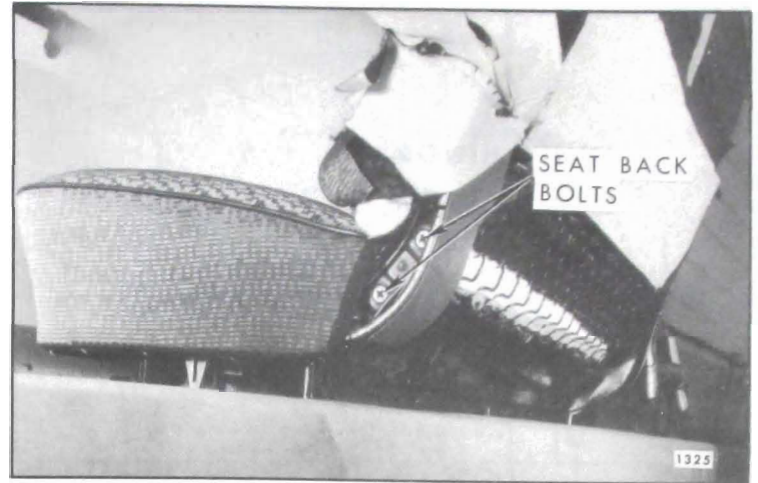

Fig. 10-22—Seat Back Attachment

“Strato” Front Seat Back Assembly (Right or Left)—Full Width Seat All Styles Except 16639 Style

Removal and Installation

1. Remove front seat assembly as described under, “Full Width Front Seat Assembly - Removal and Installation”.
2. At side of seat from which seat back is being removed, remove hog rings securing cushion side trim at rear of seat and fold trim forward sufficiently to expose two seat back outer attaching bolts (Fig. 10-23).

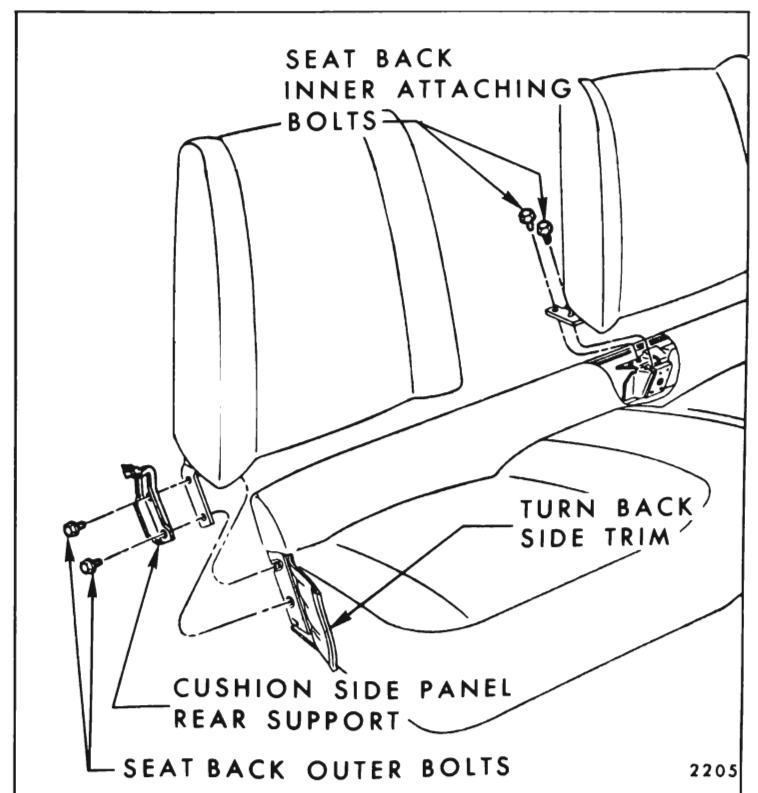

Fig. 10-23—Strato Full Width Seat Back Attachment

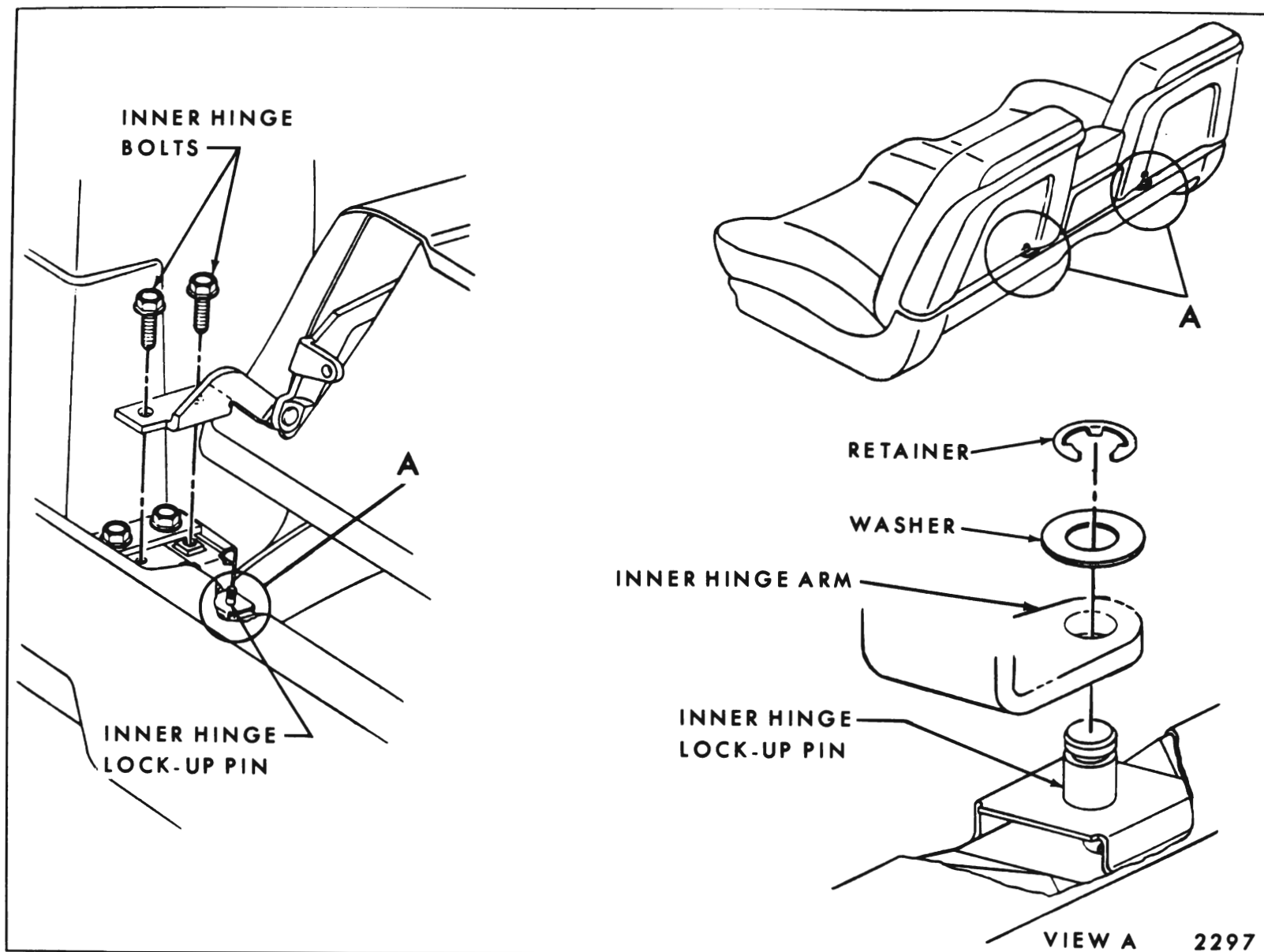

Fig: 10-24—Strato Full Width Seat Back Attachment - Chevrolet 16639 Style

3. At inboard side of seat back, remove screw securing inner attaching bolt cover plate and remove cover plate.
4. Remove seat back inner attaching bolts; then, remove outer attaching bolts and remove seat back assembly from seat.
5. To install seat back assembly, reverse removal procedure. Make certain seat side panel support (Fig. 10-23) is secured under seat back outer attaching bolts.

"Strato" Front Seat Back Assembly (Right or Left)—Full Width Seat—16639 Style

Removal and Installation

1. Remove seat assembly from body, as previously described, and place seat right side up on a clean surface.

2. Remove seat side panel on side from which seat back is being removed. Remove hog rings securing seat cushion trim side facing at rear of seat and turn side facing forward sufficiently to expose seat back outer arm attaching bolts (See Fig. 10-23).
3. Using a suitable hooked end tool between seat back and seat cushion, at location "A", remove retaining ring locking seat back at inner hinge (see View "A", Fig. 10-24).
4. Remove seat back outer arm attaching bolts (Fig. 10-23).
5. Carefully tilt seat back forward. Remove inner hinge bolt cover plate. Remove inner hinge bolts (Fig. 10-24) and carefully remove seat back from seat assembly.
6. To install, reverse removal procedure.

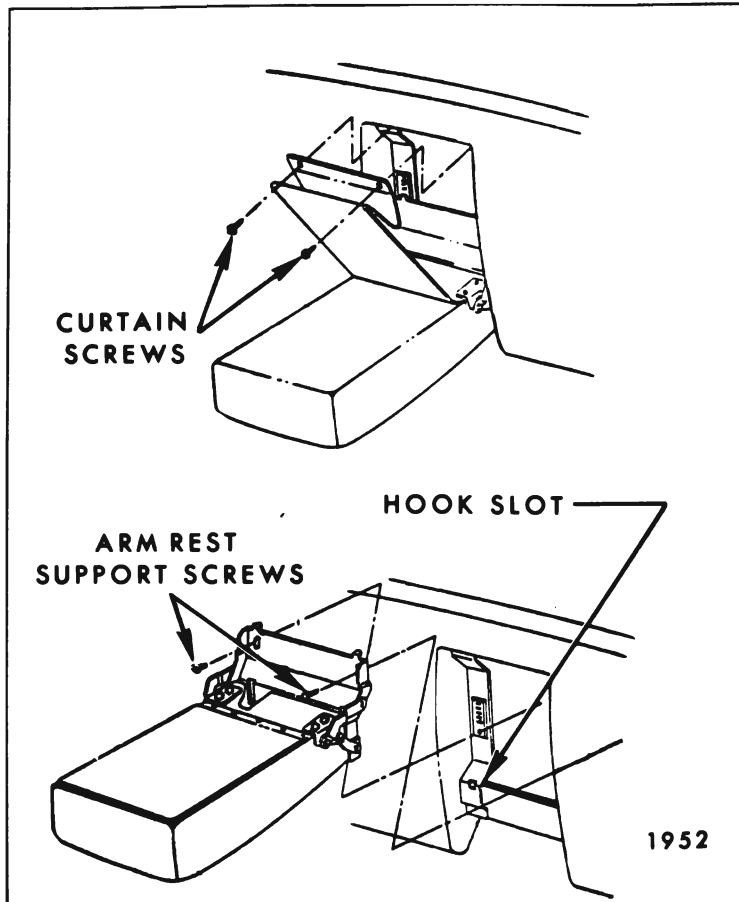

Fig. 10-25—Front Seat Center Arm Rest (Full Width Seat Back)

NOTE: It is important that removal procedure be reversed step by step when installing seat back assembly.

Standard Full Width Seat Back Head Rest (Drivers or Passengers Side)

The standard full width seat back headrest is secured by a support which is screwed or welded to the seat back frame. The support incorporates a detent spring which allows the headrest to be raised or lowered to four different height positions. The headrest can be removed from the seat back for storage by pulling the headrest bar out of the support.

To remove and install the headrest support, the seat back trim must be removed and the support-to-seat back frame screws removed.

NOTE: On styles where the support is welded to the seat back frame, the welds must be cut to remove the support.

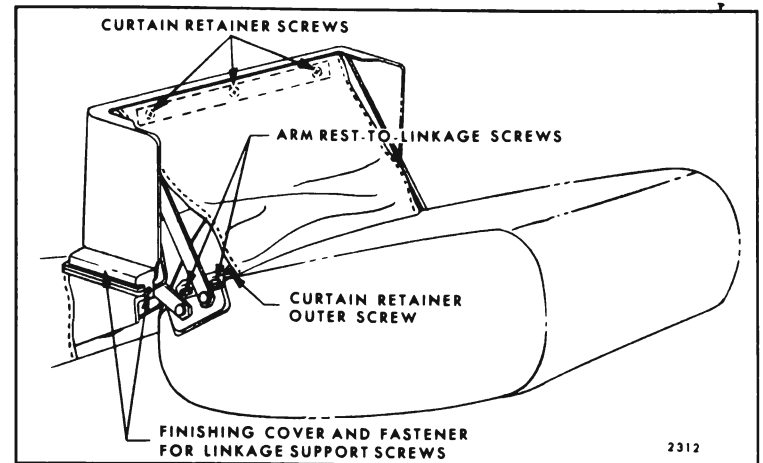

Fig. 10-26—Front Seat Center Arm Rest (Notch Down Seat Back)

FRONT SEAT CENTER ARM REST

Arm Rest and Curtain Assembly—Front Seat with Standard Full Width Seat Back

Removal and Installation

1. Place center arm rest in down position.
2. At top of arm rest curtain, remove two screws securing curtain to seat back frame (Fig. 10-25) and pull curtain forward to expose screws securing arm rest to support linkage (Fig. 10-25).
3. Remove arm rest-to-support linkage screws (Fig. 10-25) and remove arm rest and curtain from seat.
4. To install, reverse removal procedure.

Arm Rest and Support Assembly—Front Seat with Standard Full Width Seat Back

Removal and Installation

1. Place center arm rest in down position.
2. At top of arm rest curtain, remove two screws securing curtain to seat back frame (Fig. 10-25).
3. Remove two screws securing arm rest to supports on seat back (Fig. 10-25); then, carefully lift arm rest and linkage upward to disengage hooks of arm rest from slots in supports and remove assembly from seat.
4. To install, reverse removal procedure. Prior to installing curtain screws check alignment and operation of arm rest.

Front Seat Center Arm Rest and Curtain Assembly—Front Seat with Notch Down Seat Back and Strato Front Seat

Removal and Installation

1. Lower arm rest to approximately 2 inches short of full down position.
2. Carefully pull curtain back sufficiently to remove screws securing center arm rest to support linkage and loosen outer screws securing curtain retainer to arm rest (Fig. 10-26).
3. Remove screw finishing covers (Fig. 10-26). Disengage arm rest from support linkage and turn arm rest upside down on trim panel finishing cover with curtain attached. Remove three screws securing curtain retainer to trim panel finishing cover (Fig. 10-26); then remove arm rest and curtain from seat.
4. To install, reverse removal procedure.

Front Seat Center Arm Rest Assembly—Front Seat with Notch Down Seat Back and Strato Front Seat

Removal and Installation

1. Place arm rest in up position.
2. Working between arm rest and seat back, remove fastener at both sides of arm rest securing front end of screw finishing covers (Fig. 10-26).
3. Working at rear of seat, push one seat back to full forward position. Carefully pull up front of screw finishing cover sufficiently to expose arm rest support attaching screws; then remove screws (Fig. 10-27). Repeat this operation on opposite side of arm rest; then carefully remove arm rest assembly, including trim panel finishing cover, from seat.

NOTE: If washers are present between arm rest support and supports on seat (Fig. 10-27), note location and number of washers used to facilitate installation in same position. Washer(s) are used to align arm rest to front seat back(s).

4. To install, reverse removal procedure. Prior to bending down screw finishing covers check

alignment and operation of arm rest. Where necessary to align arm rest with seat back(s) install washer(s), as required, between arm rest support and supports on seat (See Fig. 10-27).

Front Seat Center Arm Rest Support—Front Seat with Notch Down Seat Back and Strato Front Seat

Removal and Installation

1. Remove center arm rest assembly.
2. Remove screws securing arm rest to support (Fig. 10-26); then, remove support from arm rest, finishing cover and curtain.
3. To install, reverse removal procedure. Prior to bending down support screw finishing covers check alignment and operation of arm rest. Where necessary to align arm rest with seat back(s), install washer(s), as required, between arm rest support and supports on seat (See Fig. 10-27).

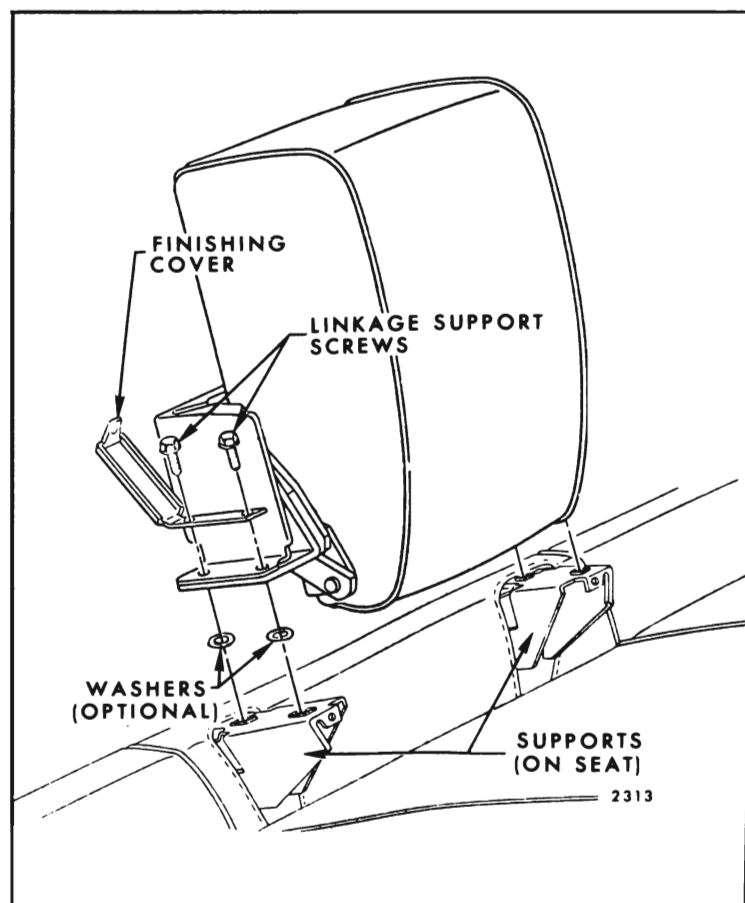

Fig. 10-27—Front Seat Center Arm Rest Support (Notch Down Seat Back)

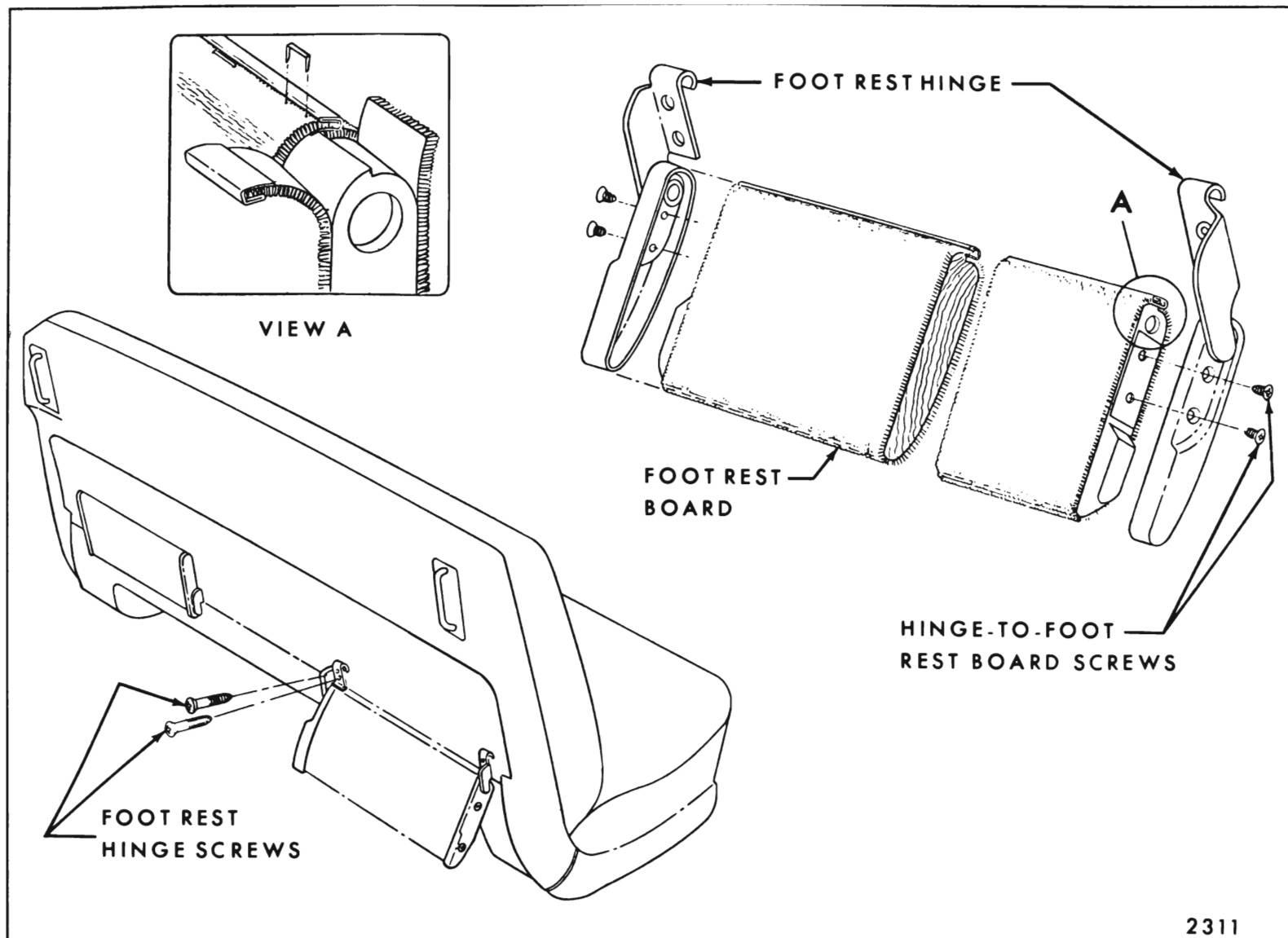

Fig. 10-28—Foot Rest Installation - Cadillac 68169 Styles

FOOT REST ASSEMBLY—CADILLAC 68169 STYLE

The folding foot rest assemblies shown in Fig. 10-28 are secured to the seat back by hinges. To remove foot rest assembly, remove hinge-to-seat

back attaching screws from both sides of foot rest (Fig. 10-28) and remove foot rest assembly from seat back. To remove trimmed foot rest board remove hinge-to-board attaching screws (Fig. 10-28) and remove hinges from foot rest board.

BUCKET SEATS

DESCRIPTION

Bucket seats, on all styles except Corvair, are a new Strato design type seat incorporating new manual and power operated seat adjusters. Optional reclining seat back with head rest are available on Pontiac, Oldsmobile, Buick and Cadillac passenger's bucket seats. The reclining seat back is operated by a control lever located at the right side of the seat cushion. When the control lever is pulled upward the seat back can be reclined to any desired position up to approximately 30° from normal position. The head rest, which is available on all Strato

seat backs, can be raised or lowered to four detent positions and can be completely removed from the seat back.

MANUALLY OPERATED BUCKET SEAT ASSEMBLY

Removal and Installation

1. Operate seat to full rearward position.

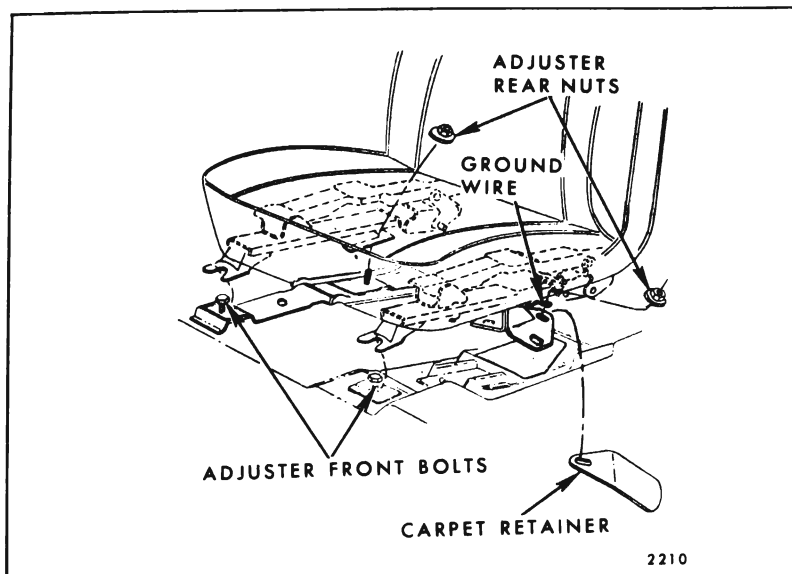

Fig. 10-29—Bucket Seat Floor Rear Attachment - "A" Styles

2. Turn back floor carpeting sufficiently to expose seat adjuster-to-floor pan attaching nuts or bolts (Fig. 10-29 or 10-30).
3. a. On "A, X & Z" body styles loosen adjuster-to-floor pan front attaching bolts (Fig. 10-29). Operate seat to full forward position. Remove adjuster-to-floor pan rear attaching bolts, then, slide seat rearward sufficiently to disengage front legs of adjusters from under front attaching bolts and remove seat assembly from body.
- b. On "B, C & E" body styles remove adjuster-to-floor pan front attaching bolts (Fig. 10-30). Operate seat to full forward position. Remove adjuster-to-floor pan rear attaching bolts and remove seat assembly from body.
4. To install, reverse removal procedure. On "A, X & Z" body styles make sure front leg of both adjusters are engaged under front attaching bolts prior to installing rear attaching nuts. Check operation of seat adjusters to full limits of travel.

POWER OPERATED HORIZONTAL OR FOUR-WAY BUCKET SEAT ASSEMBLY

The two-way and four-way (tilt) seat adjusters are actuated by a 12 volt, reversible shunt wound motor with a built-in circuit breaker.

The four-way seat adjuster operating mechanism incorporates a transmission assembly which includes two solenoids and two drive cables leading to the seat adjusters. One solenoid controls the vertical movement of the seat while the other solenoid controls the horizontal movement of the seat. When the control switch is actuated, the motor drives the

transmission by means of a belt and one of the transmission solenoids are energized simultaneously. The solenoid plunger then engages with the driving gear dog. The driving gear rotates the drive cables and operates both adjusters. When the adjusters reach their limit of travel, the drive cables stop their rotating action and torque is absorbed by the rubber belt connecting the motor and transmission. When the switch contacts are opened, a return spring returns the solenoid plunger to its original position disengaging it from the driving gear dog.

Removal and Installation

1. Operate seat to full forward position. On four-way power seats operate seat to full up position. Remove seat cushion side panels, where present. Where seat adjuster track covers are present, carefully pry out track cover snap-on retainers with a flat-bladed tool and remove track covers.
2. Where necessary, remove sill plates and turn back floor carpeting to expose seat adjuster-to-floor pan attaching nuts and bolts.
3. Remove seat adjuster-to-floor pan rear attaching bolts (Fig. 10-29 or 10-31); then, operate seat assembly to full rearward position.

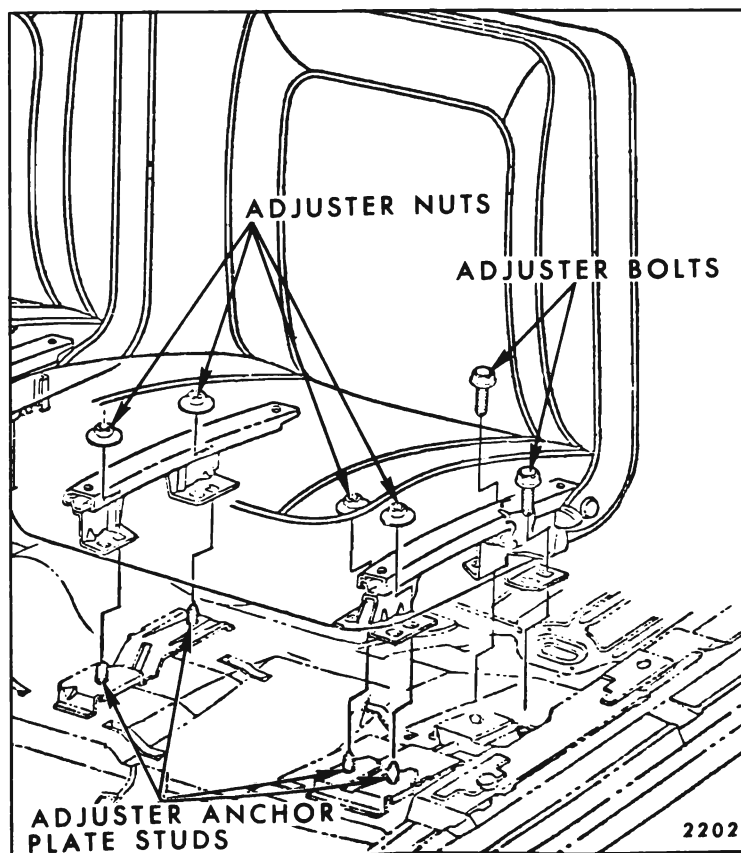

Fig. 10-30—Manually Operated Bucket Seat Floor Pan Attachment - "B & C" Styles

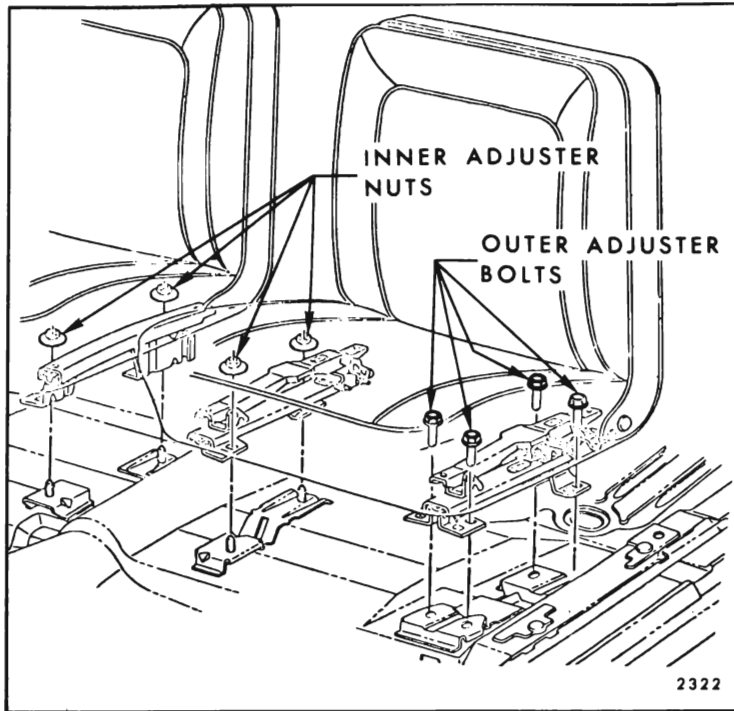

Fig. 10-31—Four-Way Bucket Seat Floor Pan Attachment - "B & C" Styles

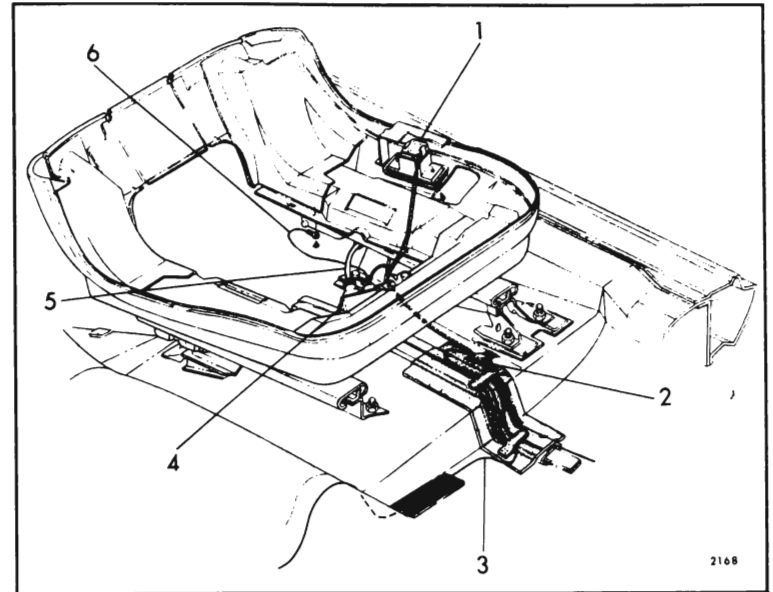

Fig. 10-33—Horizontal Bucket Seat Wiring - "B & C" Styles

- | | |
|--------------------------------|------------------|
| 1. Control Switch | 4. Motor |
| 2. Feed Harness Connector | 5. Control Cable |
| 3. Feed Wire to Passenger Seat | 6. Ground Wire |

4. a. On "A" Body Styles with power operated four-way seat adjusters loosen adjuster-to-floor pan front attaching bolts (Fig. 10-29), then, slide seat assembly rearward until front legs of adjusters are disengaged from under front attaching bolts. Tilt seat rearward sufficiently to disconnect seat harness feed connector and detach harness from clip

on floor pan (Fig. 10-32); then remove seat assembly from body.

- b. On "B, C & E" Styles with power operated seat adjusters remove seat adjuster-to-floor pan front attaching bolts (Fig. 10-31). Tilt seat rearward sufficiently to disconnect seat harness feed connector and detach harness from clip on floor pan (Fig. 10-32 or 10-33); then remove seat assembly from body.

5. To install, reverse removal procedure. Make sure ground wire is secured under adjuster inboard rear attaching nut or bolt.

On "A" Body Styles make sure adjusters are properly engaged under front attaching bolts and that rear floor carpet is properly positioned around rear supports of adjuster prior to installing carpet retainer on adjuster stud and adjuster rear attaching nuts.

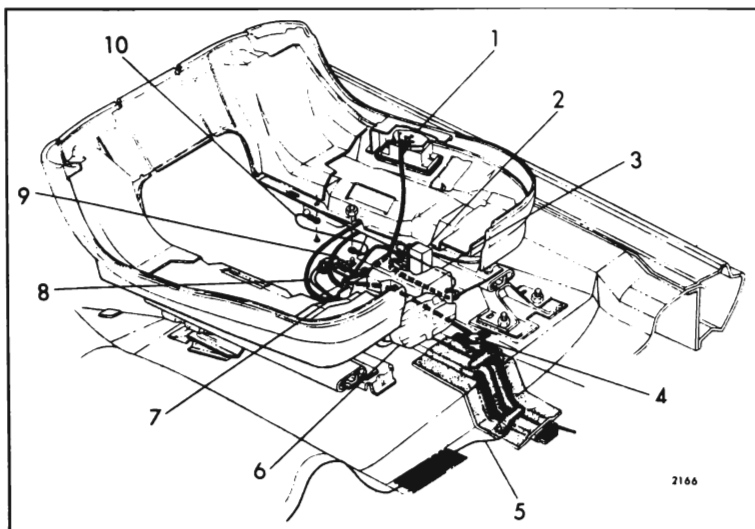

Fig. 10-32—Four-Way Strato Bucket Seat Wiring - "A & B" Styles

- | | |
|---------------------------|---------------------------------------|
| 1. Control Switch | 7. Transmission and Solenoid Assembly |
| 2. Motor Control Relay | 8. Vertical Control Cable (Orange) |
| 3. Motor | 9. Horizontal Control Cable (Black) |
| 4. Harness Feed Connector | 10. Ground Wire |
| 5. Feed to Passenger Seat | |
| 6. Pulley Cover Plate | |

MANUALLY OPERATED BUCKET SEAT ADJUSTER

Removal and Installation

1. Remove bucket seat assembly, as previously described, and place seat upside down on a protected surface.
2. If replacing inboard adjuster, remove assist spring (Fig. 10-34).

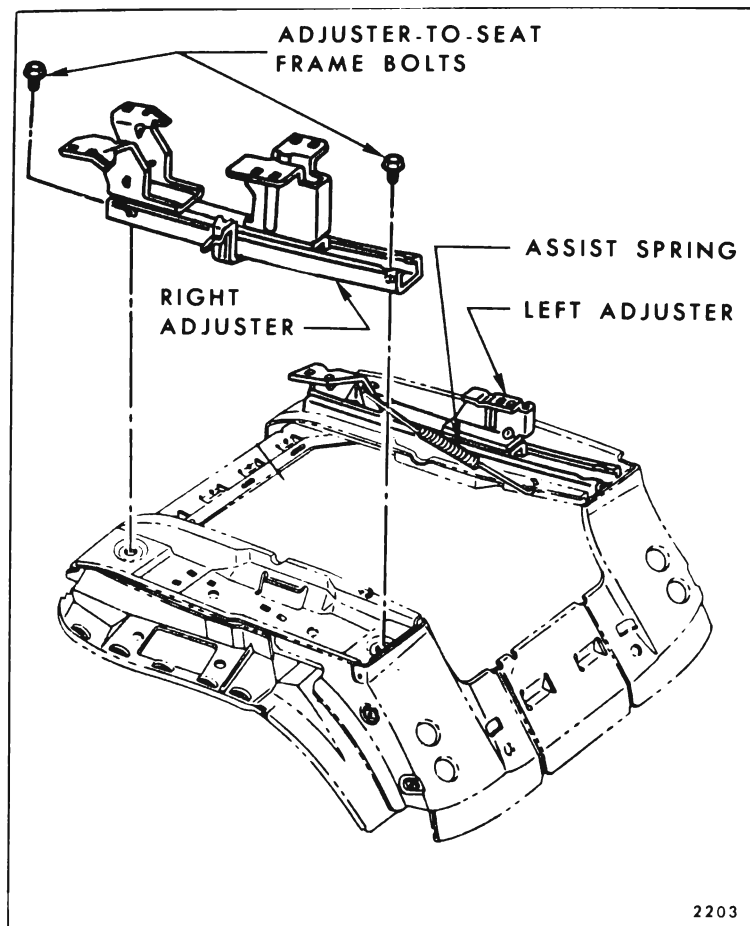

Fig. 10-34—Manual Bucket Seat Adjuster Removal

3. Operate adjuster so that both front and rear adjuster-to-seat frame attaching bolts (Fig. 10-34) are accessible; then, remove attaching bolts and remove adjuster from seat assembly.
4. To install, reverse removal procedure.

POWER OPERATED HORIZONTAL BUCKET SEAT ADJUSTER

Removal and Installation

1. Operate seat to a midway horizontal position. Remove bucket seat assembly, as previously described, and place seat upside down on a clean protected surface.
2. Disconnect power drive cable from adjuster gearnut (Fig. 10-35).
3. Remove adjuster-to-seat bottom frame front and rear attaching bolts (Fig. 10-35) and remove adjuster from seat assembly.
4. To install, reverse removal procedure. Where spacers were installed between seat adjuster and floor pan or seat adjuster and seat frame make certain spacers are reinstalled. Check for proper operation of seat to full limits of travel.

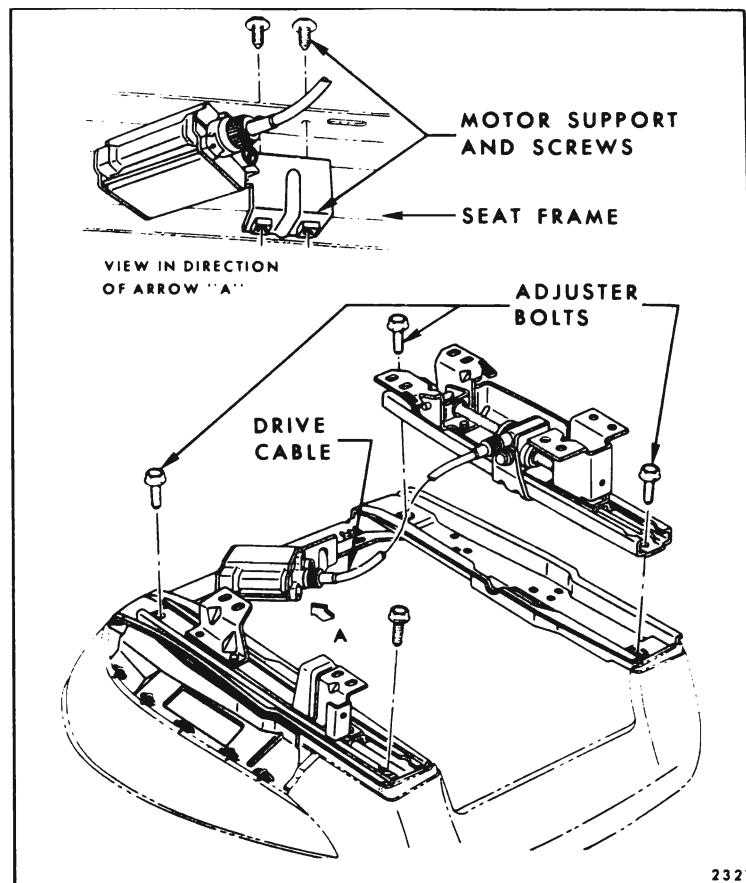

Fig. 10-35—Power Horizontal Bucket Seat Adjuster Removal

POWER OPERATED FOUR-WAY BUCKET SEAT ADJUSTER

Removal and Installation

1. Operate seat to assembly to fully raised and midway horizontal positions.

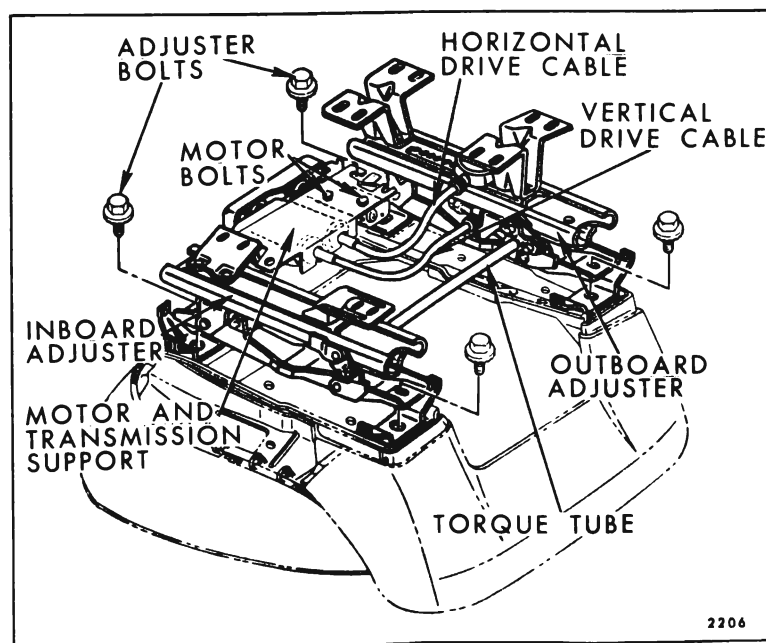

Fig. 10-36—Four-Way Bucket Seat Assembly

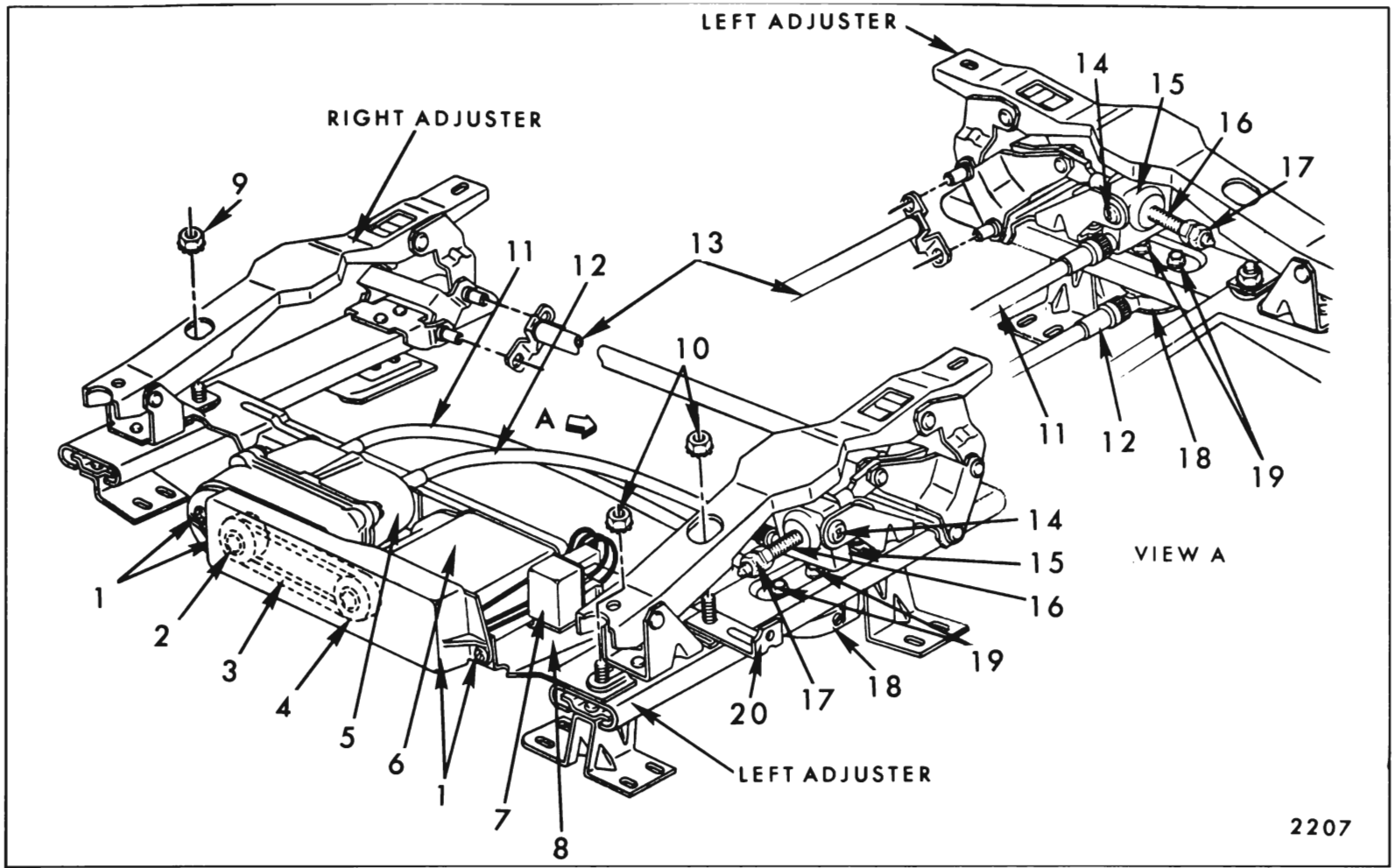

Fig. 10-37—Four-Way Bucket Seat Adjusters

- | | | | |
|---|--|--|---|
| 1. Motor and Transmission Drive Belt Cover and Attaching Screws | 7. Electric Motor Relay | 11. Adjuster Horizontal Drive Cable | 16. Adjuster Vertical Jackscrew |
| 2. Transmission Drive Pulley | 8. Motor and Transmission Support | 12. Adjuster Vertical Drive Cable | 17. Adjuster Vertical Jackscrew Stop Nuts |
| 3. Transmission and Motor Drive Belt | 9. Motor and Transmission Support-to-Right Adjuster Attaching Nut | 13. Adjuster Torque Tube | 18. Adjuster Horizontal Actuator Assembly |
| 4. Motor Drive Pulley | 10. Motor and Transmission Support-to-Left Adjuster Attaching Nuts | 14. Adjuster Vertical Gearnut Shoulder Screw | 19. Adjuster Horizontal Actuator Attaching Screws |
| 5. Transmission Assembly | | 15. Adjuster Vertical Gearnut Assembly | 20. Seat Side Panel Support |
| 6. Electric Motor Assembly | | | |

2. Remove front seat assembly from body with attached adjusters, motor and transmission, as previously described, and place upside down on a clean protected surface.

3. If outboard adjuster is being removed, disconnect bolt, horizontal and vertical drive cables from vertical gearnut and horizontal actuator (Fig. 10-36).

4. Remove nuts securing motor and transmission support to adjuster being removed (Fig. 10-37).

5. Remove adjuster-to-seat bottom frame front and rear attaching bolts securing adjuster to be removed (Fig. 10-36).

6. Carefully disengage adjuster from support, and torque tube; then, remove adjuster from seat.

7. To install power operated four-way bucket seat adjuster assembly, reverse removal procedure. Check for proper operation of seat adjusters to limits of travel.

POWER OPERATED FOUR-WAY BUCKET SEAT ADJUSTER MAJOR COMPONENTS

The following service procedures cover replacement of the major component parts of the power operated four-way seat adjuster, used on bucket seats.

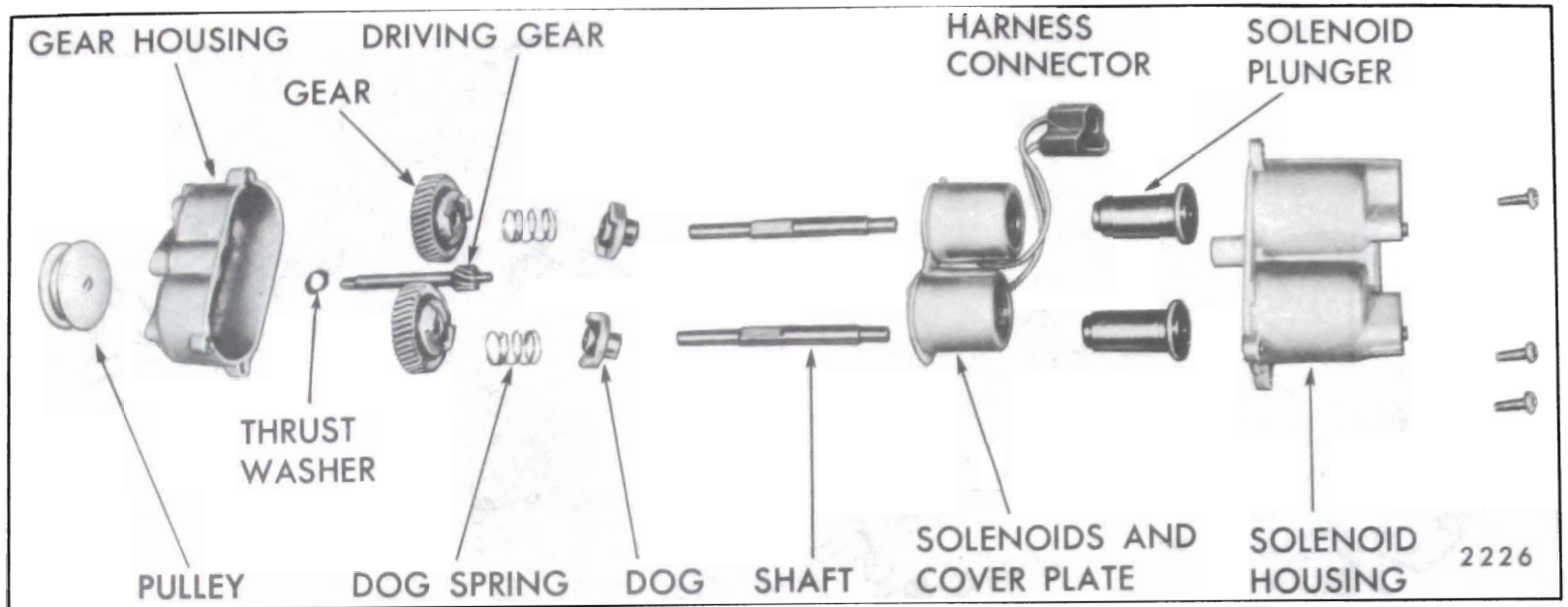

Fig. 10-38—Four-Way Bucket Seat Transmission

Motor and Transmission Drive Belt and Pulleys

Removal and Installation

1. At front of seat motor and transmission drive belt cover remove attaching screws (Fig. 10-37) and remove cover.
2. Remove drive belt (Fig. 10-37) from both motor and transmission drive pulleys. Pulleys may be removed from either motor or transmission by pulling pulleys off their respective shaft.
3. To install drive belt, reverse removal procedure. Check for proper operation of seats to full limits of travel.

Motor Assembly

Removal and Installation

1. If motor can be operated, operate seat assembly to full "up" position. Disconnect wire harness connector from motor relay.
2. Remove motor-to-transmission drive belt cover and drive belt, as previously described.
3. From under motor and transmission support remove two cap screws securing motor to motor-and-transmission support and remove motor assembly from under seat.
4. To install, reverse removal procedure. Check for proper operation of seat to full limits of travel.

Transmission Assembly and Horizontal and Vertical Drive Cables

Removal and Installation

1. Remove front seat assembly from body with attached adjusters, motor and transmission, as previously described, and place upside down on a protected surface.
2. Disconnect wire harness connector from transmission.
3. Remove motor and transmission drive belt cover and remove drive belt (Fig. 10-37).
4. Remove two screws securing transmission assembly to motor and transmission support; then, move transmission forward to disengage from drive cables and remove transmission from seat.

NOTE: To remove horizontal or vertical drive cables detach drive cable from adjuster and remove cable.

Disassembly and Assembly of Transmission

1. Remove front seat adjuster transmission from seat assembly.
2. Remove screws securing gear and solenoid housings together; then, carefully separate housings and remove component parts of transmission assembly (Fig. 10-38).
3. To assemble transmission, reverse removal procedure.

IMPORTANT: Prior to or during installation, lubricate frictional surfaces of driving gear thrust washer, gears, dog washers, shaft and solenoid plungers with "Lubriplate" (630AAW) or equivalent.

4. To install transmission assembly, reverse removal procedure. Make certain drive cables are properly engaged in transmission and properly retained in cut out notches of motor and transmission support prior to installing transmission attaching screws.
5. Check for proper operation of seat to full limits of travel.

Adjuster Vertical Gearnut

Removal and Installation

1. Operate seat assembly to fully raised and mid-way horizontal position.
2. Remove front seat assembly from body and place upside down on a clean protected surface.
3. Using a clutch type screwdriver or other suitable tool, remove shoulder screws securing linkage to vertical gearnut (Fig. 10-37).
4. Remove jackscrew "down" stop from jackscrew (Fig. 10-37).
5. Using a portable power source to energize the motor, actuate vertical gearnut until gearnut is disengaged from jackscrew.

NOTE: It may be necessary to manually raise or lower upper rear portion of adjuster to gain clearance for removal of gearnut.

6. Disconnect drive cable from gearnut.
7. To install, reverse removal procedure. Check seat adjusters for proper operation.

Adjuster Jackscrew

Removal and Installation

1. Remove adjuster gearnut as previously described.
2. Remove seat adjuster-to-seat bottom frame front and rear attaching bolts.
3. As a bench operation, remove jackscrew-to-adjuster linkage attaching rivet and remove jackscrew from adjuster assembly (Fig. 10-37).

NOTE: It may be necessary to manually raise or lower upper rear portion of adjuster to gain access to jackscrew attaching rivet.

4. To install, reverse removal procedure. Use new rivet to attach jackscrew-to-adjuster linkage. Check seat adjusters for proper operation.

Adjuster Horizontal Actuator Assembly

Removal and Installation

1. Remove front seat assembly from body as previously described and place upside down on a clean protected surface.
2. Using a clutch type screwdriver or other suitable tool, remove shoulder screws securing linkage to vertical gearnut (Fig. 10-37).
3. Using a portable power source, actuate vertical gearnut until gearnut is against "down" stop on jackscrew assembly.
4. Disconnect drive cable from horizontal actuator assembly.
5. Remove screws securing horizontal actuator assembly to adjuster lower track; then remove actuator from adjuster assembly (Fig. 10-37).
6. To install, reverse removal procedure.

NOTE: When installing horizontal actuator, adjuster actuator so that drive gear is fully engaged with teeth on lower channel. When horizontal actuator attaching screws are tightened, there should be no free motion between upper and lower channels. Re-adjust actuator "as required" until all free motion between channels has been removed. Check seat adjusters for proper operation.

Torque Tube Assembly

Removal and Installation

1. Remove inboard seat adjuster assembly, as previously described.
2. Disengage torque tube from outboard adjuster (Fig. 10-36 and 10-37) and remove torque tube assembly.
3. To install torque tube assembly, reverse removal procedure. Check for proper operation of seat to full limits of travel.

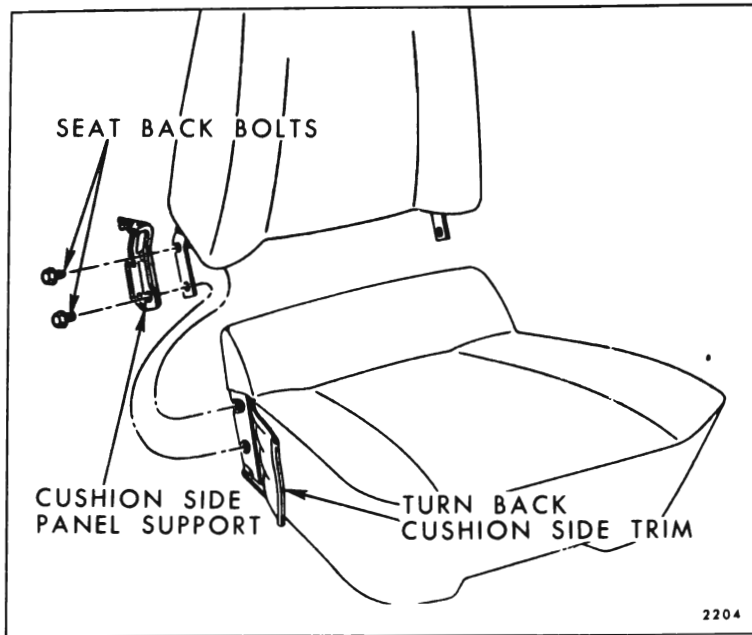

Fig. 10-39—Bucket Seat Back Removal (Without Reclining Seat Back) All Except Corvaire

STANDARD BUCKET SEAT BACK ASSEMBLY—ALL TWO DOOR STYLES EXCEPT CORVAIRE

Removal and Installation

1. Remove bucket seat assembly from body, as previously described, and place on a clean protected surface.
2. Remove hog rings at both sides of seat securing cushion side trim at rear of seat and fold trim forward sufficiently to expose four seat back attaching bolts (Fig. 10-39).



Fig. 10-40—Bucket Seat Back Removal - Corvaire

3. Remove seat back attaching bolts at both sides of seat and remove side panel support and seat back assembly from seat cushion assembly.
4. To install seat back assembly, reverse removal procedure. Make certain seat side panel support is secured under seat back outer attaching bolts.

STANDARD BUCKET SEAT BACK ASSEMBLY—CORVAIRE

Removal and Installation

1. Using a flat-bladed tool, carefully remove retainer from inner and outer hinge pin (Fig. 10-40).

NOTE: On 10000 Series, remove screw securing hinge arm cover (Fig. 10-41) and remove cover; then, remove inner hinge pin retainer.

2. Carefully disengage inner and outer front seat back hinge arms from pins; then remove seat back assembly from body.
3. To install, reverse removal procedure. Prior to installation of back assembly, be sure inner and outer washers are installed over hinge pins. In addition, inspect hinge arm retainers. If retainers are damaged, replace retainers using new parts.

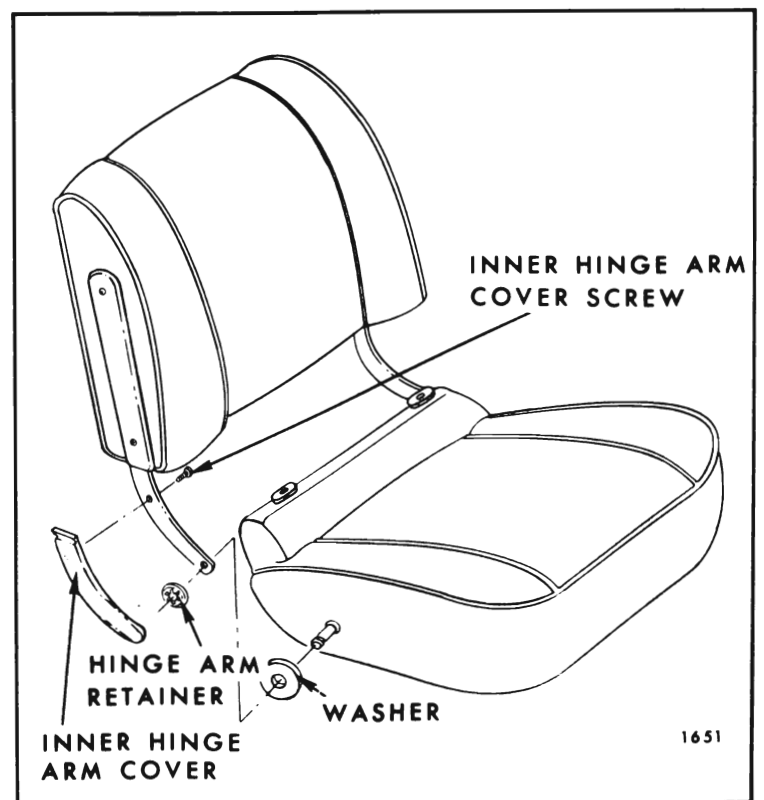

Fig. 10-41—Bucket Seat Back Inner "Hinge" Arm—Corvaire

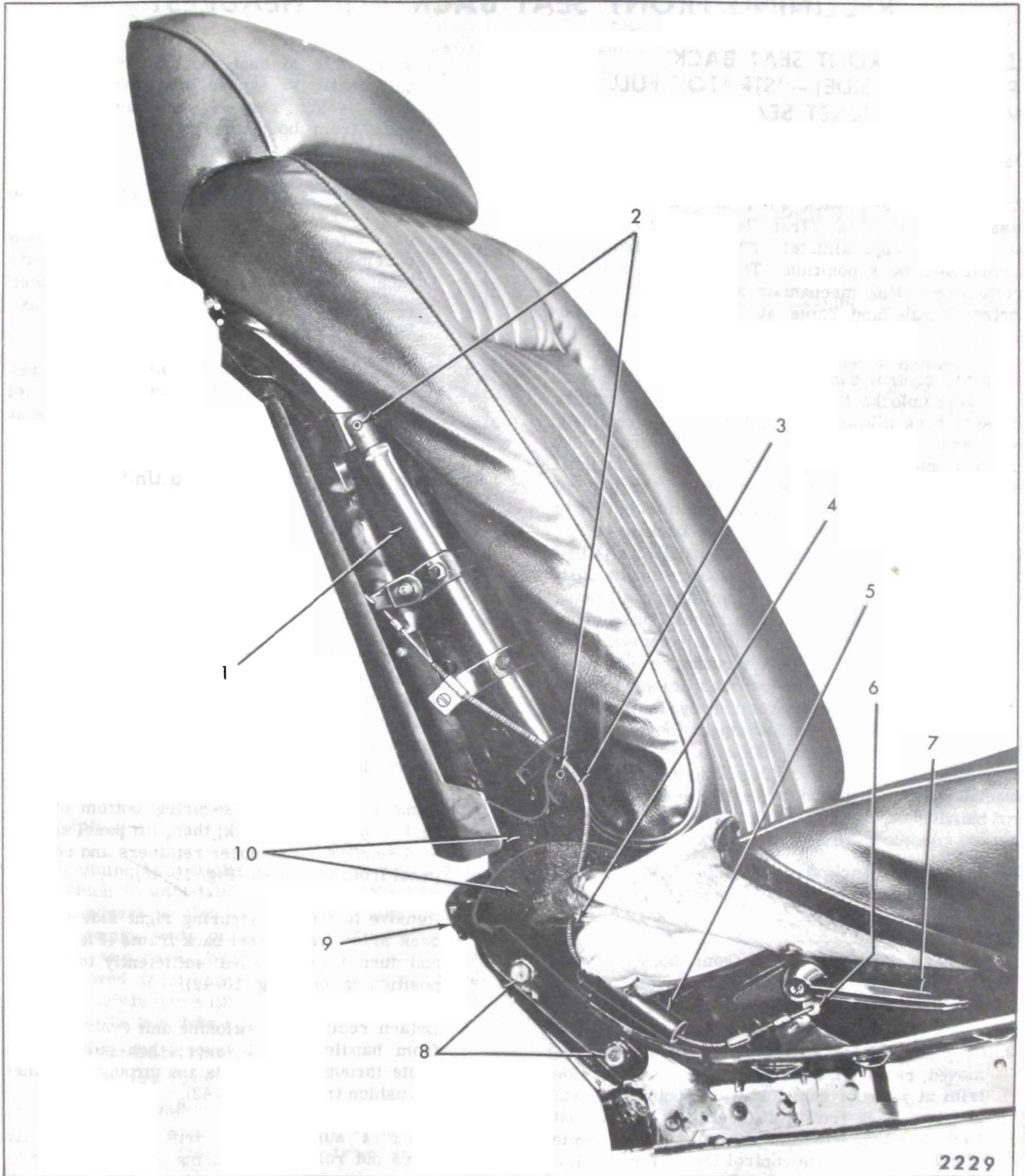

Fig. 10-42—Reclining Seat Back and Positioning Unit

- | | | |
|---|--|---|
| 1. Reclining Positioning Unit | 4. Control Cable Grommet in Cushion Trim | 8. Seat Back Hinge Attaching Bolts |
| 2. Positioning Unit Attaching Roll Pins | 5. Control Cable Guide | 9. Seat Cushion Side Panel Rear Support |
| 3. Positioning Unit Control Cable | 6. Handle Control Lever | 10. Seat Back Hinge |
| | 7. Control Handle | |

RECLINING FRONT SEAT BACK AND HEADREST

RECLINING FRONT SEAT BACK (PASSENGER SIDE)—“STRATO” FULL WIDTH OR BUCKET SEAT

Description

The reclining seat back which is available on the passenger seat of the Strato design front seats can be reclined approximately 30 degrees from the normal seat back position. The reclining unit is a friction operating mechanism and is actuated by a control handle and cable at the right side of the seat.

When the control handle is pulled upward the control cable unlocks the reclining positioning unit in the seat back allowing the seat back to be reclined, by means of rearward pressure on the seat back, to a maximum of approximately 30 degrees or until the control handle is released. When the control handle is released the reclining positioning unit is locked and will not allow the seat back to be reclined further. When the control handle is pulled up and there is no rearward pressure on the seat back, the assist spring in the reclining positioning unit will return the seat to the normal position or to a position at which the handle is released. The friction mechanism of the positioning unit will allow the seat back to be moved forward to the normal position with approximately four pounds manual forward push at the top of the seat back. This “dress-up” feature allows the driver or passenger to return a reclined seat back to its normal position without having to operate the control handle.

Reclining Seat Back Assembly

Removal and Installation

1. Remove seat assembly from body, as described, and place upside down on a clean protected surface.
2. On right side of seat with seat side panel removed, remove hog rings securing cushion side trim at rear of seat and along bottom of seat and turn back trim sufficiently to expose seat back attaching bolts and reclining control cable attachment at handle control lever (Fig. 10-42).
3. Detach reclining positioning unit control cable from handle control lever; then pull control cable through cable guide and through grommet in cushion trim (Fig. 10-42).
4. a. On reclining bucket seat remove hog rings securing cushion side trim facing on in-

board side of seat and turn trim forward sufficiently to expose seat back attaching bolts. Then remove seat back attaching bolts from both sides of seat and remove seat back assembly from seat.

- b. On reclining full width seat, remove screw at inboard side of seat back securing seat back attaching bolt cover plate and remove cover plate. Remove seat back inner attaching bolts then, remove seat back outer attaching bolts and remove seat back assembly from seat.
5. To install seat back assembly, reverse removal procedure. Make certain side panel support (Fig. 10-42) is secured under seat back outer attaching bolts.

Reclining Seat Back Positioning Unit

Removal and Installation

1. Remove seat assembly from body, as previously described, and place upside down on a clean protected surface.
2. On right side of seat with seat side panel removed, removed hog rings securing cushion side trim at rear of seat and along bottom of seat and turn back trim sufficiently to expose reclining control cable attachment at handle control lever (Fig. 10-42).
3. Remove two screws securing bottom of seat back panel to seat back; then, lift panel upward to disengage from upper retainers and remove panel from seat back (Fig. 10-43).
4. Remove hog rings securing right side of seat back side trim to seat back frame (Fig. 10-43) and turn trim forward sufficiently to expose positioning unit (Fig. 10-42).
5. Detach reclining positioning unit control cable from handle control lever; then pull control cable through cable guide and through grommet in cushion trim (Fig. 10-42).
6. Using a suitable size drift punch carefully drive out roll pins securing positioning unit to support on seat back frame and to seat back hinge (Fig. 10-42); then remove positioning unit from seat back.

IMPORTANT: If roll pins do not drive out easily use a suitable back up to prevent possible damage or breakage of the positioning unit or mounting brackets.

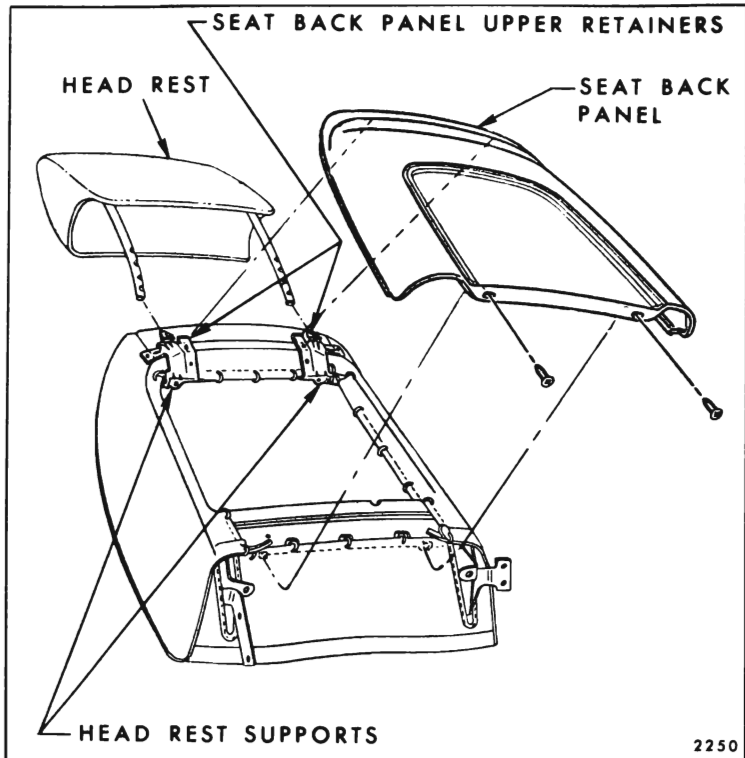

Fig. 10-43—Strato Seat Back Panel and Headrest

Where necessary, remove control cable from positioning unit.

7. To install reclining seat back positioning unit, reverse removal procedure. Check for proper operation of reclining seat back to full limits of travel.

STRATO SEAT BACK HEADREST

Description

All reclining seat backs are equipped with a headrest which is adjustable to four different positions. This headrest is also available as an option on all Strato design seats on either the drivers or passengers seat back. When desired, the headrest can be removed from the seat back; however, it requires slightly more lifting effort to clear the headrest past the last detent position.

Strato Seat Back Headrest Support Guide Tube

Removal and Installation

1. Remove headrest assembly from seat back.
2. Remove support finishing escutcheon screw and remove escutcheon (Fig. 10-44).
3. Carefully pull plastic support guide tube out of support. If guide tube hangs up on detent spring insert a screwdriver into guide and depress detent spring sufficiently to remove guide tube.

4. To install support guide tube reverse removal procedure. Make certain lower end of plastic guide is inserted into hole in bottom of support and that cut out in guide for detent spring is facing rearward (Fig. 10-44). Check for proper operation of headrest.

Strato Seat Back Headrest Supports

Removal and Installation

1. Remove headrest assembly from seat back.
2. Remove two screws securing bottom of seat back panel; then, lift panel upward to disengage from upper retainers and remove panel from seat back (Fig. 10-43).
3. Remove headrest support finishing escutcheon screw and remove escutcheon (Fig. 10-44).
4. Remove four remaining support attaching screws (Fig. 10-44) and remove support from seat back. Where required, remove support guide from support.
5. To install headrest support, reverse removal procedure. Make certain lower end of plastic guide is inserted into hole in bottom of support and that cut out in guide for detent spring is facing rearward (Fig. 10-44). Prior to tightening support attaching screws, install headrest into supports and align support(s) with headrest arm(s); then, tighten support screws.
6. Check for proper operation of headrest.

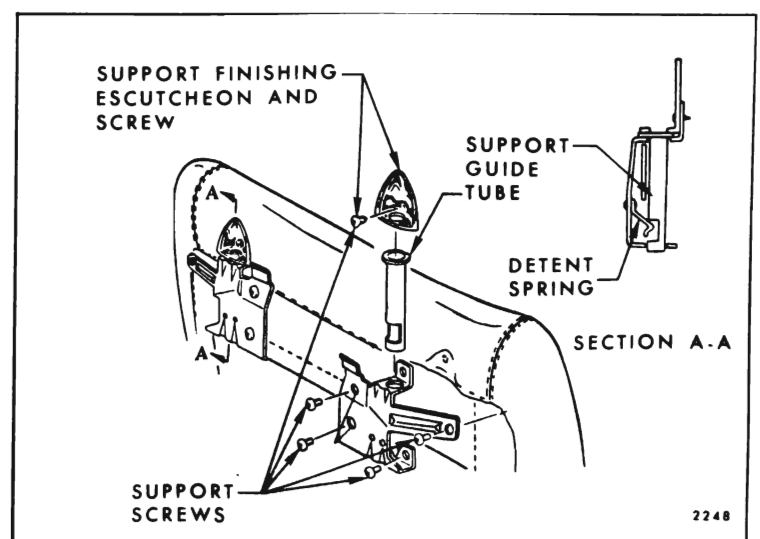

Fig. 10-44—Strato Seat Back Head Rest Support

REAR SEAT

REAR SEAT CUSHION—ALL STYLES

Removal

1. Push lower forward edge of cushion rearward and pull cushion upward until wire protrusions on seat bottom frame disengage from floor pan retainers at each side of seat.

NOTE: On "E" Body Styles lift up front of seat cushion sharply to disengage cushion from pan retainers.

2. Pull cushion forward and carefully remove from body.

Installation

1. Carefully lift cushion into body using caution not to damage adjacent trim.
2. Position rear edge of cushion under rear seat back assembly.
3. Center wire protrusions on seat bottom with retainers on or in floor pan.

IMPORTANT: If seat bottom frame protrusions are not properly centered in relation to retainers on floor pan, proper engagement and placement of cushion will be extremely difficult.

4. Push forward edge of cushion rearward and downward until protrusions are properly engaged behind retainers on floor pan.

REAR SEAT BACK ASSEMBLY—ALL STYLES EXCEPT CORVAIR

Removal and Installation

1. Remove rear seat cushion assembly.
2. At bottom of seat back bend out the tabs securing the lower portion of seat back to floor panel. On convertible styles, remove screw from rear side of seat back support panel securing upper corners of seat back to panel. If screws are used securing center of seat back to seat back panel it will be necessary to remove screws from inside rear compartment.

Remove two screws securing lower portion of seat back to floor pan.

3. Pull seat back assembly out at the bottom until seat back clears body tabs; then, on all styles except "E" Styles raise seat back upward until disengaged from hangers on the seat back panel support. On "E" Styles push seat back downward until wire protrusions at top of seat back are disengaged from slots in seat back panel support.
4. Remove seat back assembly from body.
5. To install, reverse removal procedure, making certain that all attaching body tabs and hangers have industrial body tape applied to them to act as an anti-squeak.

REAR SEAT BACK CENTER ARM REST AND CURTAIN

Removal and Installation

1. Lower rear seat back arm rest. On all styles except 68069 carefully pull upper portion of arm rest curtain out of slot in hanger plate and fold curtain forward. On 68069 Style fold arm rest flipper forward.
2. Remove four screws securing arm rest to hanger plate linkage then, remove arm rest from seat back.
3. To install, reverse removal procedure.

REAR SEAT BACK CENTER ARM REST HANGER PLATE AND LINKAGE

Removal and Installation

1. Remove rear seat back center arm rest; then, remove two screws securing arm rest hanger plate to body seat back support brace. Remove rear seat back.
2. On back side of rear seat back, remove four screws securing arm rest hanger plate to seat back supports; then, carefully remove arm rest and hanger plate assembly from seat back (Fig. 10-45).
3. To install, reverse removal procedure. Prior to tightening hanger plate screws move arm rest assembly upward until top is snug against top of opening in seat back.

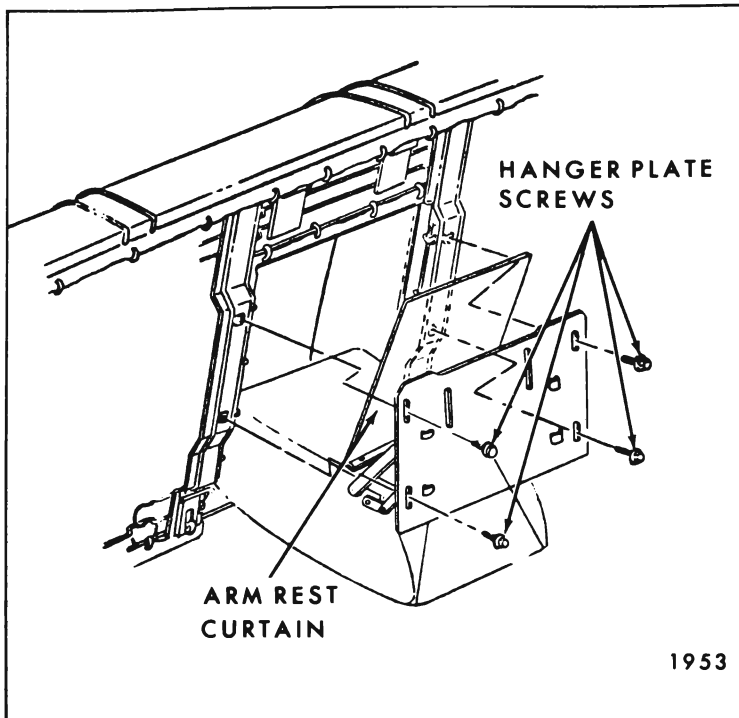

Fig. 10-45—Rear Seat Back Arm Rest and Hanger Plate

FOLDING REAR SEAT BACK AND FILLER PANEL—CORVAIR

Folding Rear Seat Back Assembly

Removal and Installation

1. Remove rear seat back cushion, as previously described.
2. Lower folding seat back; then, remove three screws from both sides of seat back securing seat back to folding linkage.
3. Carefully disengage seat back from linkage and remove folding seat back from body.

4. To install, reverse removal procedure.

Folding Rear Seat Back Linkage

Removal and Installation

1. Remove rear seat cushion and folding seat back, as previously described.
2. Mark position of linkage on floor pan. Remove bolts securing folding seat back linkage to floor pan and remove linkage.
3. To install, reverse removal procedure. Align linkage on floor pan with previously made alignment marks.

Rear Folding Seat Back Filler Panel—10039 Style

Removal and Installation

1. Remove rear seat cushion, as previously described; then lower folding seat back.
2. Lift up seat back filler panel sufficiently to gain access to attaching screws and prop panel in this position.

NOTE: Prop should be wide enough to bear against hinge and hold hinge in position during removal of hinge attaching screws.

3. Remove filler panel hinge attaching screws; then remove prop and remove filler panel.
4. To install, reverse removal procedure.

STATION WAGON FOLDING REAR SEATS AND FLOOR PANELS—"B" BODY (CHEVROLET 15-16000 SERIES AND PONTIAC 25-26000 SERIES)

DESCRIPTION

The following views are typical of the station wagon folding seats and rear compartment floor panels. These illustrations identify the component panels of the rear compartment area and their relationship.

Figure 10-46 is typical of 15000 and 16000 two-seat station wagons.

Figure 10-47 is typical of 15000 and 16000 three-seat station wagons with split second seat option.

Figure 10-48 is typical of 25000 and 26000 two-seat station wagons.

Figure 10-49 is typical of 25000 three-seat station wagons with split second seat option.

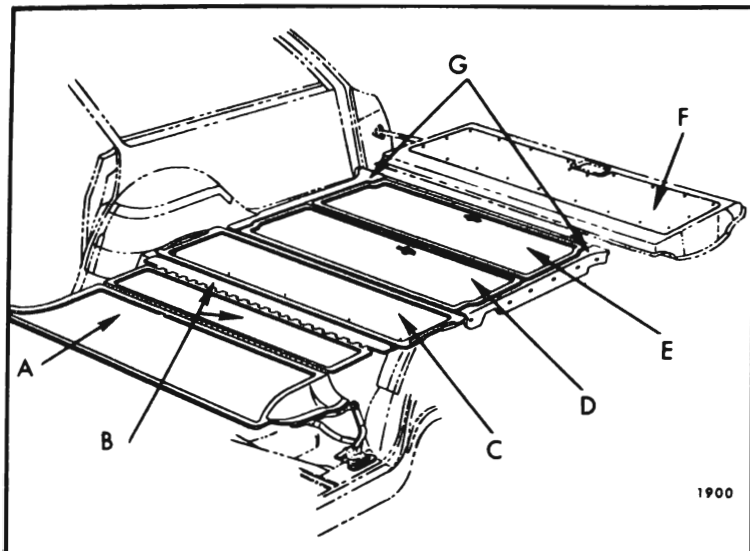

Fig. 10-46—Folding Seat and Floor Panels
Chevrolet "B-35" Styles

- | | |
|------------------------------------|---------------------------------------|
| A. Second Seat Back Panel | E. Luggage Compartment Rear Panel |
| B. Rear Floor Filler Panel | F. Tail Gate Inner Cover Panel |
| C. Compartment Floor Panel | G. Compartment Pan Side Filler Panels |
| D. Luggage Compartment Front Panel | |

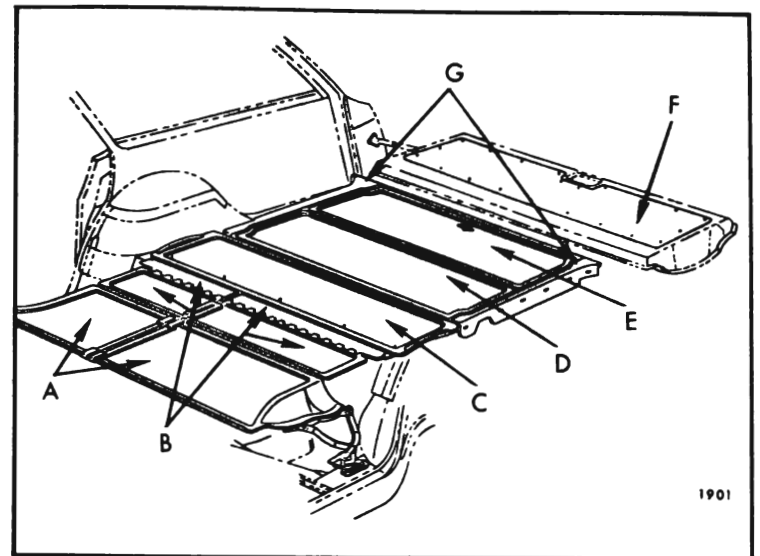

Fig 10-47—Folding Seats and Floor Panels
Chevrolet "B-45" Styles

- | | |
|---|---------------------------------------|
| A. Second Seat Back Panels (Split Option) | D. Third Seat Back Panel |
| B. Rear Floor Filler Panels | E. Third Seat Cushion Panel |
| C. Compartment Floor Panel (at Kick-Up) | F. Tail Gate Inner Cover Panel |
| | G. Compartment Pan Side Filler Panels |

REAR FLOOR TO TAIL GATE FILLER PANEL ASSEMBLY 25-26000 SERIES

Removal and Installation

1. Lower tail gate assembly.
2. Lift up rear edge of filler panel assembly

sufficiently to expose attaching screws along forward edge of panel.

3. Remove filler panel attaching screws and remove panel assembly from body opening.
4. To install, reverse removal procedure.

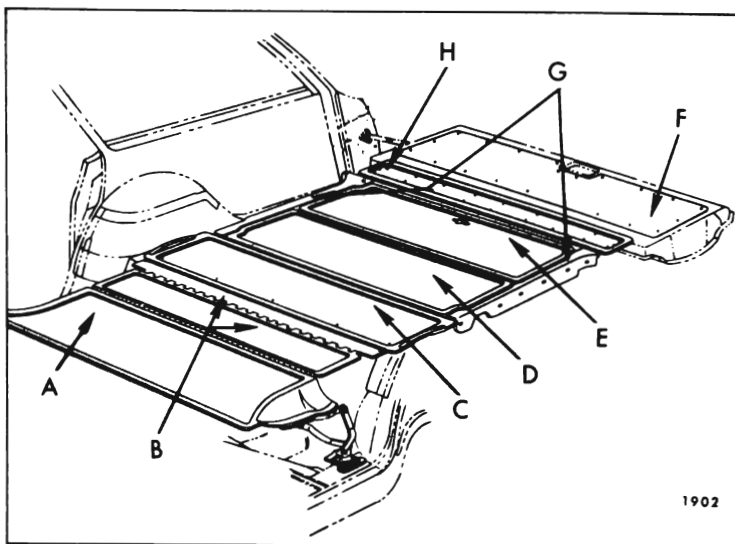

Fig. 10-48—Folding Seat and Floor Panels
Pontiac "B-35" Styles

- | | |
|---|---------------------------------------|
| A. Second Seat Back Panel | E. Luggage Compartment Rear Panel |
| B. Rear Floor Filler Panel | F. Tail Gate Inner Cover Panel |
| C. Compartment Floor Panel (at Kick-Up) | G. Compartment Pan Side Filler Panels |
| D. Luggage Compartment Front Panel | H. Rear Floor-to-Tail Gate Panel |

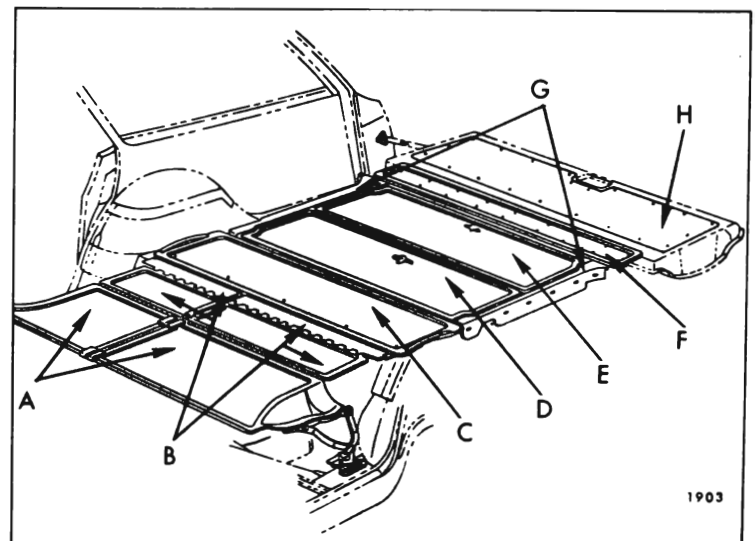

Fig. 10-49—Folding Seats and Floor Panels
Pontiac "B-45"

- | | |
|---|---------------------------------------|
| A. Second Seat Back Panels (Split Option) | E. Third Seat Cushion Panel |
| B. Rear Floor Filler Panels | F. Rear Floor-to-Tail Gate Panel |
| C. Compartment Floor Panel (at Kick-Up) | G. Compartment Pan Side Filler Panels |
| D. Third Seat Back Panel | H. Tail Gate Inner Cover Panel |

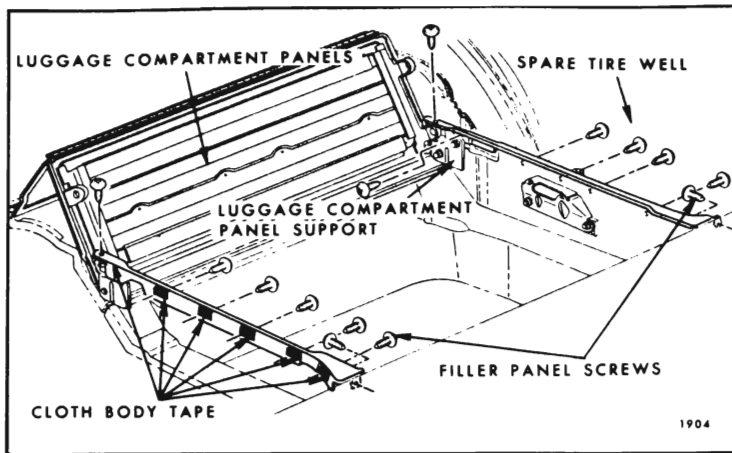

Fig. 10-50—Rear Compartment Pan Side Filler Panels

COMPARTMENT PAN SIDE FILLER PANEL (RIGHT OR LEFT SIDE) ALL STYLES

Removal and Installation:

1. On "35" Styles, use handle and fold rear luggage compartment panel forward until it is resting entirely on front luggage compartment panel (Fig. 10-50).
2. On "45" Styles, raise folding 3rd seat back assembly to up position; then raise 3rd seat bottom cushion assembly to up or "sitting" position.
3. For right floor side panel, remove spare tire cover panel.
4. On left side, remove screw which secures floor side panel to panel support.
5. Along inboard and outboard side facing of right and/or left panel, remove screws which secure panel to panel supports (Fig. 10-50) and remove panel(s) from body.
6. To install, reverse removal procedure. If installing new filler panel, apply cloth body tape over all screw attaching holes. (See Fig. 10-50).

LUGGAGE COMPARTMENT FRONT AND REAR PANEL ASSEMBLIES TWO-SEAT STYLES

Removal and Installation

1. Using handle, fold rear luggage compartment panel forward until it is resting entirely on front luggage compartment panel.
2. Fold combined front and rear luggage compartment panels to "up" or half open position. (See Fig. 10-50).

3. Remove bolt (Fig. 10-51) at both sides of front panel securing front and rear panel assemblies to supports; then remove assembly from body.
4. To install, reverse removal procedure. Make sure bushing and spring washer are properly installed (Fig. 10-51).

NOTE: When replacing front luggage compartment panel with new part, transfer rear luggage compartment panel with attached hinge to new part.

LUGGAGE COMPARTMENT REAR PANEL ASSEMBLY TWO-SEAT STYLES

Removal and Installation

1. Using handle, fold rear luggage compartment panel forward until it is resting entirely on front luggage compartment panel.
2. Remove screws securing hinge assembly to rear luggage compartment panel and remove panel assembly from body.
3. To install, reverse removal procedure.

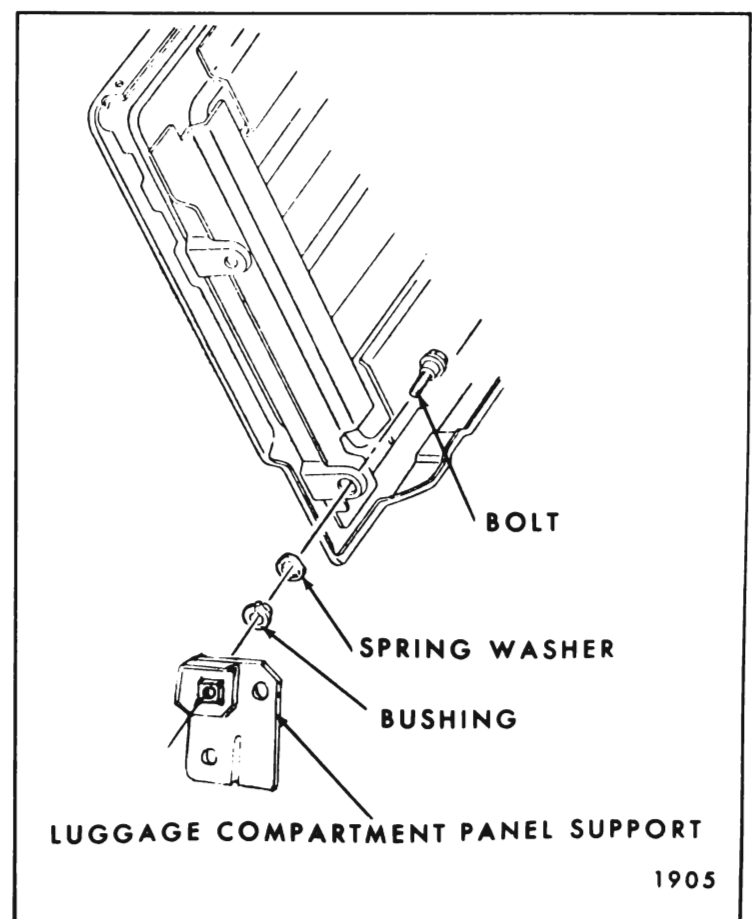

Fig. 10-51—Luggage Compartment Panel Attachment to Body

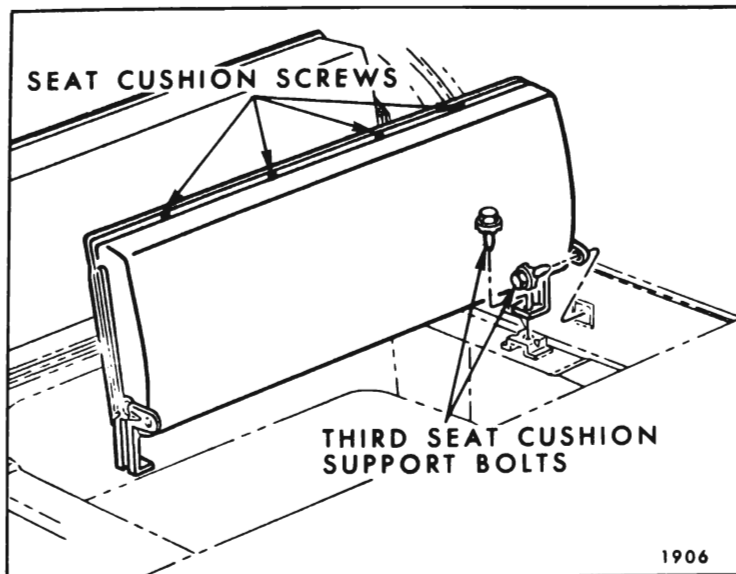

Fig. 10-52—Folding Third Seat Cushion

LUGGAGE COMPARTMENT FRONT AND REAR PANEL HINGE ASSEMBLY

Removal and Installation

1. Using handle, fold rear luggage compartment panel forward until it is resting entirely on front luggage compartment panel.
2. Remove screws securing hinge assembly to both front and rear panels and remove hinge from body.
3. To install, reverse removal procedure.

FOLDING THIRD SEAT CUSHION THREE-SEAT STYLES

Removal and Installation

1. Lift third seat cushion to a half raised position or approximately vertical to floor pan (Fig. 10-52).
2. Remove four seat cushion screws from rearward edge of cushion (Fig. 10-52).
3. Pull rear edge of cushion away from flange of cushion panel then lift cushion upward to disengage cushion border wire from four tabs on panel. Remove cushion from body and place on a clean protected surface.
4. To install, reverse removal procedure. Make sure cushion border wire is engaged with all four panel tabs prior to installing cushion attaching screws.

FOLDING THIRD SEAT CUSHION, PANEL ASSEMBLY AND SUPPORT THREE-SEAT STYLES

Removal and Installation

1. Lift third seat cushion to a half raised position or approximately vertical to floor pan. (See Fig. 10-52).
2. Remove two bolts at each side of seat securing supports to body (Fig. 10-52); then, remove seat cushion, panel assembly and supports from body and place on a clean protected surface.

To remove support, remove cushion from panel assembly; then remove bolt securing support to cushion (Fig. 10-53).

3. To install, reverse removal procedure. If support was removed from seat cushion panel, make sure bushing and spring washer are properly installed. (See Fig. 10-53).

FOLDING THIRD SEAT BACK TRIM ASSEMBLY THREE-SEAT STYLES

Removal and Installation

1. Raise third seat back assembly - leave cushion assembly in down position.
2. Remove four screws securing lower edge of seat back trim to seat back panel. (See Fig. 10-54).
3. Pull lower edge of seat back trim slightly rearward; then, lift trim assembly upward to disengage trim border wire from four tabs on

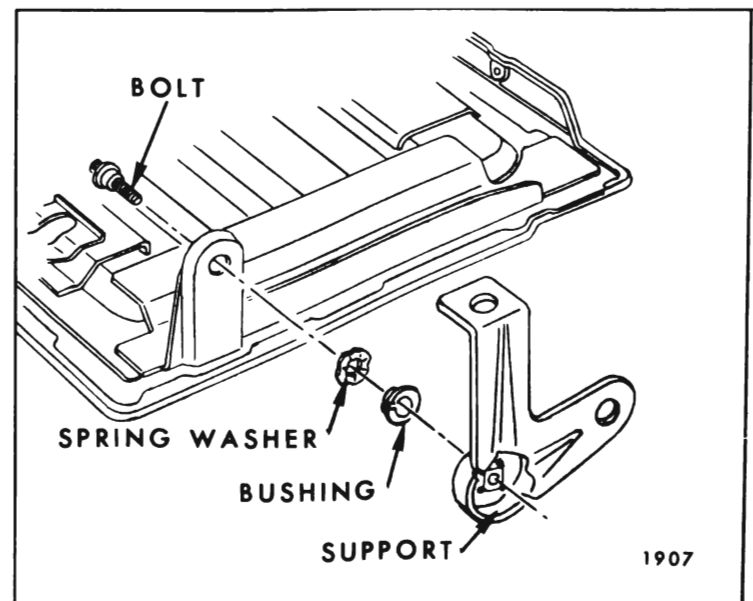

Fig. 10-53—Third Seat Cushion Panel and Support

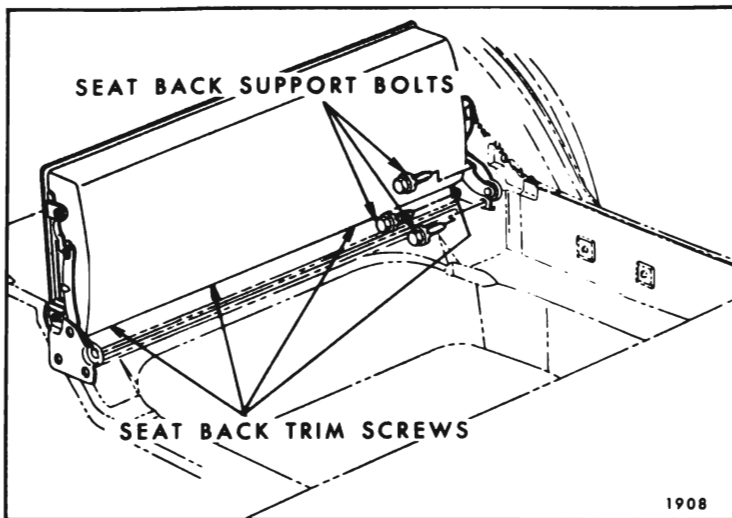

Fig. 10-54—Folding Third Seat Back

upper portion of panel. Remove trim assembly from body and place on a clean protected surface.

4. To install, reverse removal procedure. Make sure seat back trim border wire is engaged with all four panel tabs at upper portion of panel prior to installing seat back trim attaching screws.

FOLDING THIRD SEAT BACK PANEL ASSEMBLY THREE-SEAT STYLES

Removal and Installation

1. Remove third seat back trim assembly
2. At both sides of third seat back panel remove seat back linkage bolt (Fig. 10-55) and bolt securing seat back panel to support (Fig. 10-55); then remove seat back panel assembly from body.
3. To install, reverse removal procedure.

COMPARTMENT FLOOR PANEL ASSEMBLY (AT KICK-UP) ALL STYLES

Removal and Installation

1. On "45" Styles, remove folding 3rd seat back assembly as previously described.
2. On "35" Styles, remove luggage compartment front and rear panel assemblies (complete) as previously described.
3. Directly under rear edge of compartment floor panel remove four screws securing panel to floor pan.

4. At front of compartment floor panel remove five screws securing panel to floor pan; then, remove compartment floor panel from body.
5. To install, reverse removal procedure.

REAR FLOOR FILLER PANEL ALL STYLES

Removal and Installation

1. Remove compartment floor panel assembly (at kick-up) as previously described.
2. Along rear edge of filler panel, remove screws which secure panel to floor pan.
3. Fold filler panel forward sufficiently to remove screws which secure panel to folding 2nd seat back assembly and remove filler panel from body.
4. To install, reverse removal procedure.

SECOND SEAT CUSHION (FULL WIDTH OR SPLIT SEAT) ALL STYLES

Removal and Installation

1. Lift up front edge of folding rear seat cushion assembly to disengage seat bottom frame from slots in rear seat support on floor pan; then, remove cushion assembly from body and place on a clean protected surface.
2. To install, reverse removal procedure. Make certain that seat cushion frame is fully engaged in supports on floor pan.

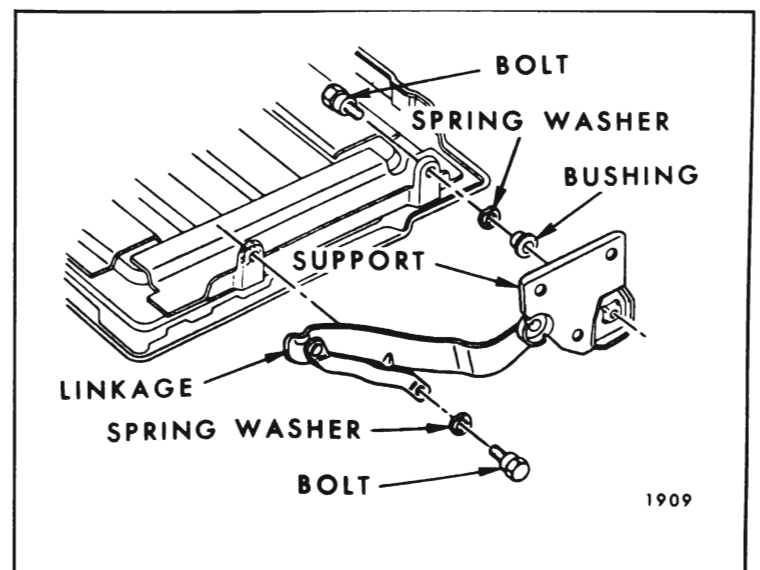

Fig. 10-55—Third Seat Back Panel and Linkage

FOLDING SECOND SEAT BACK TRIM ASSEMBLY (FULL WIDTH OR SPLIT SEAT) ALL STYLES

Removal and Installation

1. Raise folding second seat back and remove second seat cushion.
2. On underside of second seat back panel, remove screws securing seat back trim assembly to seat back panel.

NOTE: Do not remove screws securing rear floor filler panel hinge to second seat back panel.

3. Pull lower edge of seat back trim slightly forward; then lift trim assembly upward to disengage trim border wire from tabs on upper portion of panel. Remove trim assembly from body and place on a clean protected surface.
4. To install, reverse removal procedure. Make sure seat back trim border wire is engaged with panel tabs at upper portion of seat back panel prior to installing seat back trim attaching screws.

2. On underside of folding second seat back remove screws securing rear floor filler panel hinge to seat back panel.

NOTE: Do not remove screws securing seat back trim assembly to seat back panel.

3. Mark position of folding second seat back linkage supports on floor pan. Remove nuts from both sides of seat back securing linkage supports to floor pan (See Figure 10-56), full width seat (Fig. 10-57) for split seat.

Lift seat back assembly with attached linkage from body and place on a clean protected surface.

4. To remove linkage from folding second seat back remove linkage-to-seat back panel attaching bolts and remove linkage - See (Fig. 10-58 for full width seat) (Fig. 10-59 for split seat).
5. To install, reverse removal procedure. If linkage was removed from split seat back, make sure bushings and spring washers are properly installed prior to installing linkage attaching bolts. (See Fig. 10-59).

FOLDING SECOND SEAT BACK TRIM, PANEL AND LINKAGE ASSEMBLY (FULL WIDTH OR SPLIT SEAT) ALL STYLES

Removal and Installation

1. Raise folding second seat back and remove second seat cushion.

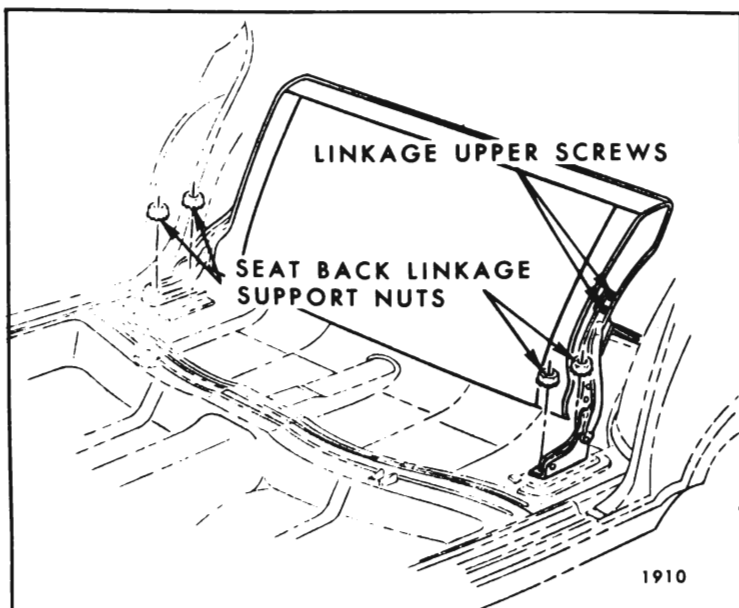

Fig. 10-56—Folding Second Seat Back Supports (Full Width Seat)

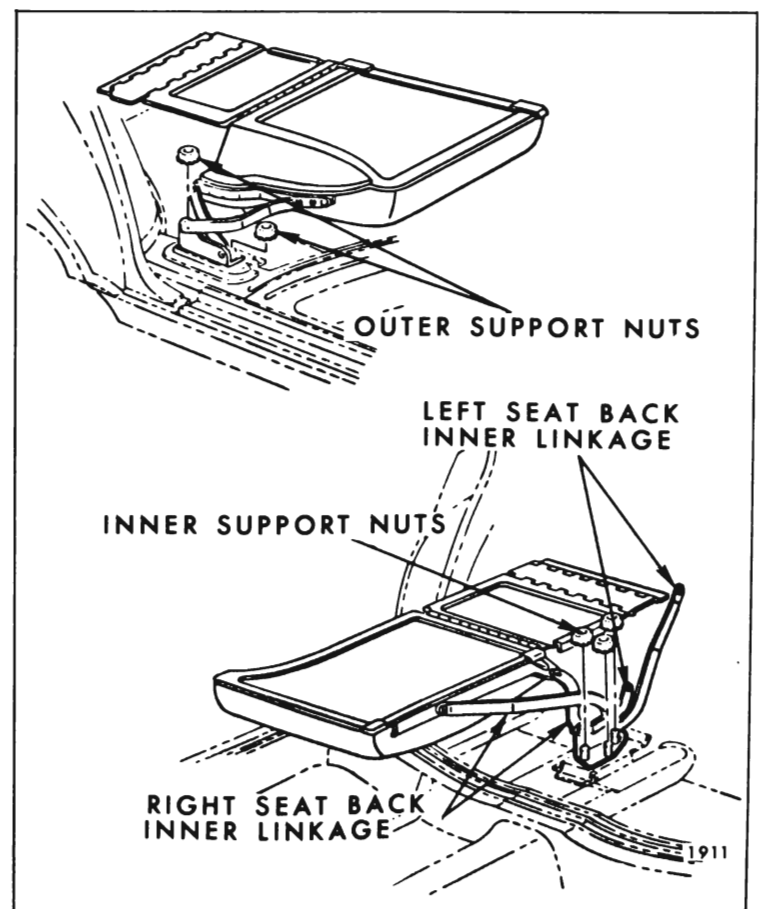

Fig. 10-57—Folding Second Seat Back Supports and Linkages (Split Seat)

FOLDING SECOND SEAT BACK LINKAGE ASSEMBLY (FULL WIDTH SEAT—RIGHT OR LEFT SIDE SPLIT SEAT— OUTER LINKAGE ONLY) ALL STYLES

If both right and left linkage assemblies are to be removed on full width second seat remove second seat back trim, panel and linkage assembly and remove linkage from seat back panel as described under "Folding Second Seat Back Trim, Panel and Linkage Assembly - Removal and Installation".

If one linkage assembly (right or left side) is to be removed proceed as follows:

Removal and Installation

1. Remove second seat cushion.
2. Move folding second seat back forward just sufficiently to remove two lower linkage-to-seat back panel attaching screws. (See Fig. 10-58).
3. Carefully return seat back to full up position; then, place a support under seat back assembly to support seat back in this position.
4. Remove two upper linkage-to-seat back panel attaching screws. (See Fig. 10-58).
5. Remove nuts securing linkage support to floor pan (See Fig. 10-56); then carefully remove linkage assembly from seat back and floor pan.
6. To install, reverse removal procedure.

FOLDING SECOND SPLIT SEAT BACK INNER LINKAGE ASSEMBLY ALL STYLES

Removal and Installation

1. Remove left second seat cushion and place left seat back in full up position. Place a support under right side of left seat back to support seat back in this position.
2. Place right seat back in partially down position (resting on seat cushion).
3. Remove nuts securing inner linkage assembly to floor pan (See Fig. 10-57).
4. Remove inner linkage-to-seat back bolts from both right and left seats (See Fig. 10-59); then carefully disengage inner linkage from seat backs and floor pan studs and remove linkage assembly.

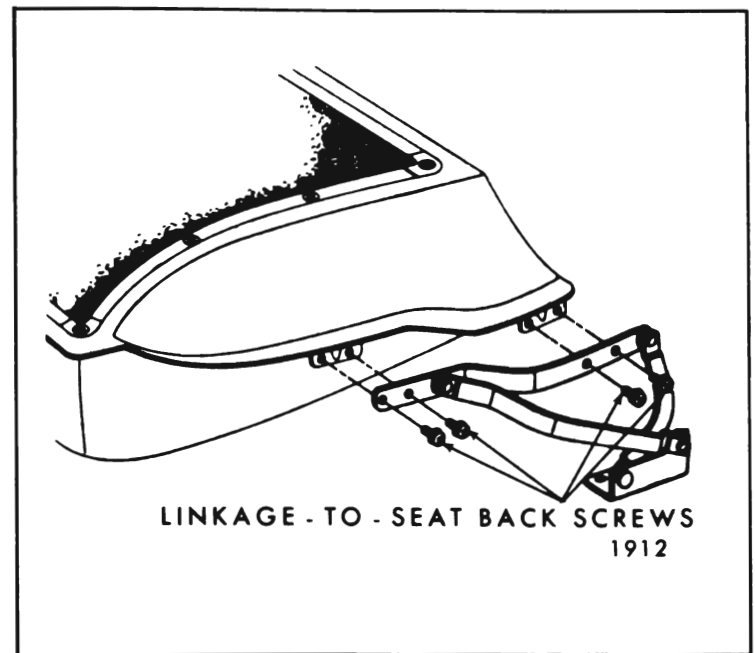

Fig. 10-58—Folding Second Seat Back Supports and Linkage (Full Width Seats)

5. To install, reverse removal procedure. Make sure bushings and spring washers are properly installed prior to installing linkage attaching bolts to both right and left seat back panels. (See Fig. 10-59).

FOLDING SECOND SEAT BACK CATCH ASSEMBLY ALL 25-26000 STYLES

Removal and Installation

1. Fold second seat back forward.
2. Remove catch cover screws and remove cover (Fig. 10-60).
3. Remove three screws securing catch to seat back frame and remove catch assembly from seat back (Fig. 10-60).
4. To install, reverse removal procedure.

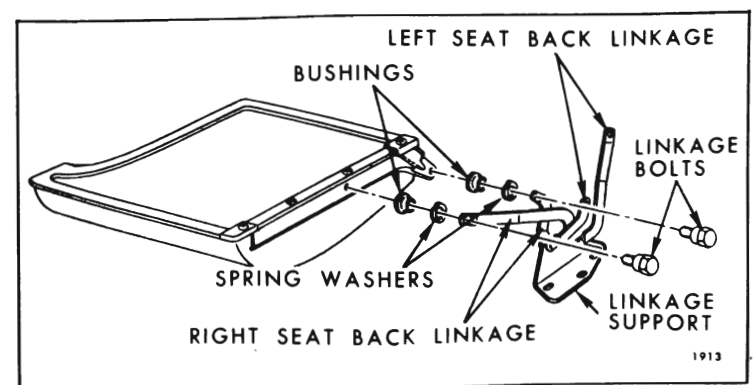

Fig. 10-59—Folding Second Seat Back Inner Linkage and Support

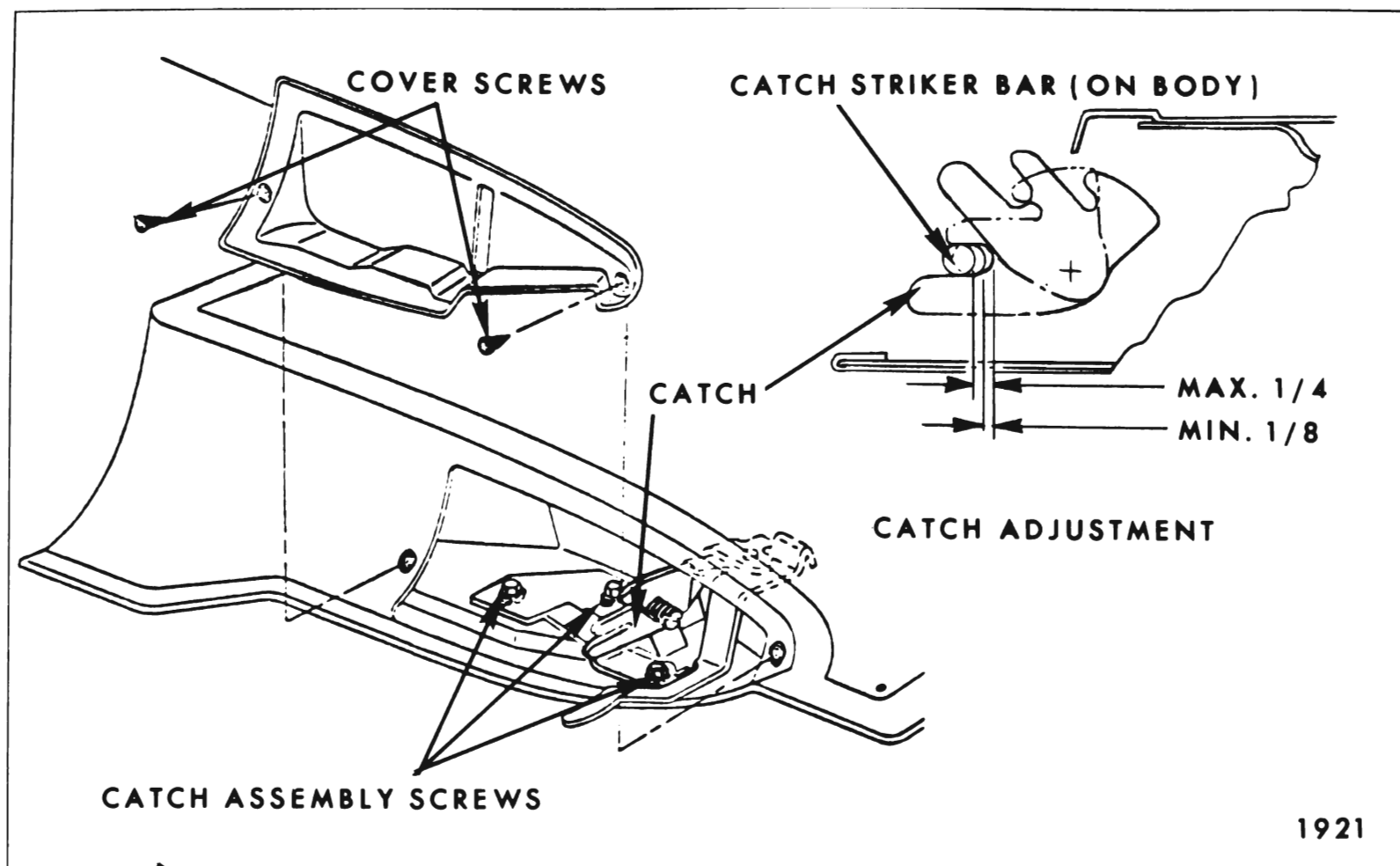

Fig. 10-60—Folding Seat Back Catch - All Pontiac "B" Styles

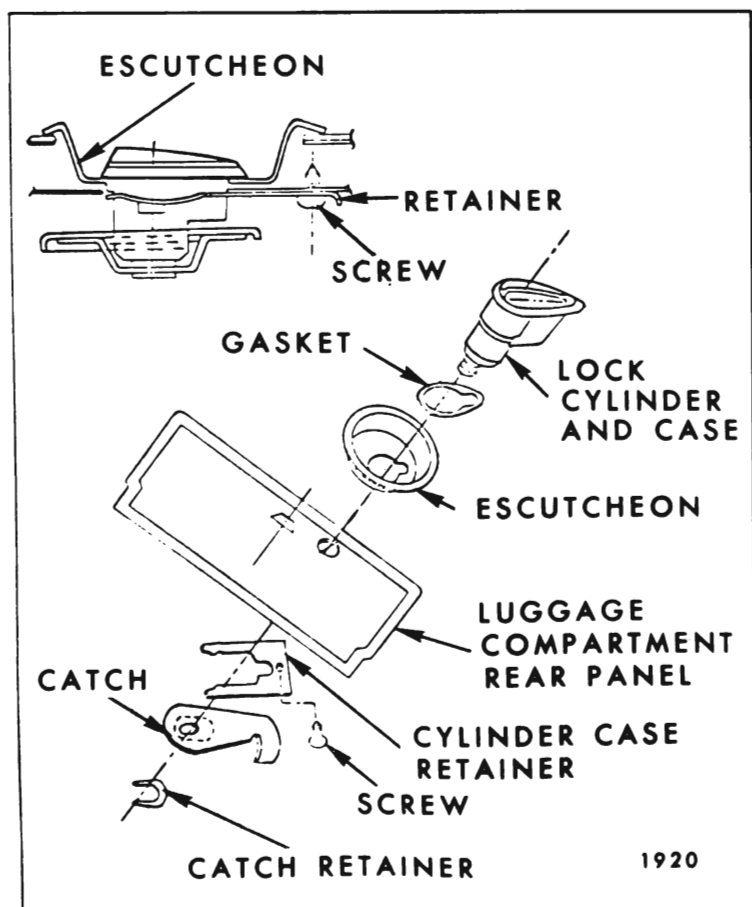

Fig. 10-61—Luggage Compartment Lock Chevrolet "B" Styles

IMPORTANT: To assure proper operation of the folding second seat back the catch assembly should be installed and, where necessary, adjusted for a minimum gap of $1/64$ inch to a maximum gap of $3/16$ inch between bottom of slot in catch and catch striker when seat back is in full "up" position (Fig. 10-60).

LUGGAGE COMPARTMENT LOCK CYLINDER (OPTIONAL EQUIPMENT) 15-16000 TWO-SEAT STYLES

Removal and Installation

1. Open luggage compartment rear panel.
2. On underside of luggage compartment rear panel remove catch retainer and catch from lock cylinder case (Fig. 10-61); then turn lock cylinder with key until cylinder can be removed from case.
3. To install, reverse removal procedure.

LUGGAGE COMPARTMENT LOCK (OPTIONAL EQUIPMENT) 15-16000 TWO-SEAT STYLES

Removal and Installation

1. Open luggage compartment rear panel.

2. On underside of luggage compartment rear panel, remove catch retainer and catch (Fig. 10-61).
3. Remove lock cylinder case retainer screw and

retainer (Fig. 10-61); then, remove lock cylinder and case, gasket and escutcheon from panel (Fig. 10-61).

4. To install, reverse removal procedure.

STATION WAGON FOLDING SEATS AND FLOOR PANELS—"A" BODY EXCEPT "65" STYLES

DESCRIPTION

Figures 10-62 and 10-63 are typical of two-seat station wagon folding full second seat and rear compartment floor panels. The illustration identifies component parts, their relationship and various attaching points.

REAR COMPARTMENT FLOOR PANEL COVERING STYLES WITH RUBBER MAT

The rear compartment floor panel cover consists of a one-piece rubber mat with a pad backing. The rubber mat is installed loose with sides inserted under rear quarter trim and wheelhouse trim assemblies.

REAR COMPARTMENT FLOOR PANEL COVERING STYLES WITH VINYL MAT

The rear compartment floor panel covering consists of a one-piece vinyl mat with a pad backing. The vinyl mat is installed loose with sides inserted under the rear quarter trim and wheelhouse trim assemblies. The 23535 Style incorporates metal skid strips which are tabbed to the vinyl mat.

REAR COMPARTMENT FLOOR PANEL COVERING STYLES WITH FLOOR CARPET

A one-piece rear compartment floor panel carpet with a pad backing is available as an option. The carpet is retained at the front and rear edges by finishing moldings which are secured to the floor panel by screws. (See Fig. 10-63). The sides of the carpet are inserted under the rear quarter trim and wheelhouse trim assemblies.

REAR SEAT CUSHION ASSEMBLY TWO-SEAT STYLES

Removal and Installation

1. Lift up front edge of cushion assembly to disengage protrusions on seat bottom frame from slots in seat cushion support and remove cushion assembly.
2. To install, reverse removal procedure. Make certain protrusions on seat bottom frame are fully engaged in slots in seat cushion support.

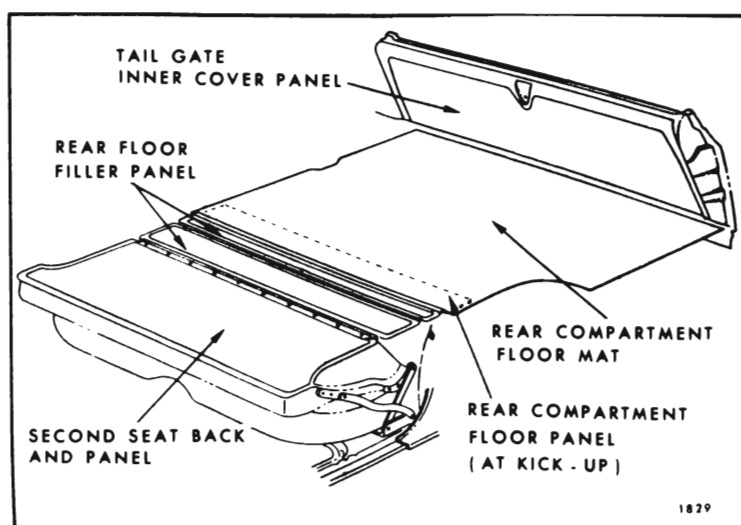

Fig. 10-62—Folding Second Seat and Rear Floor Panel Covers

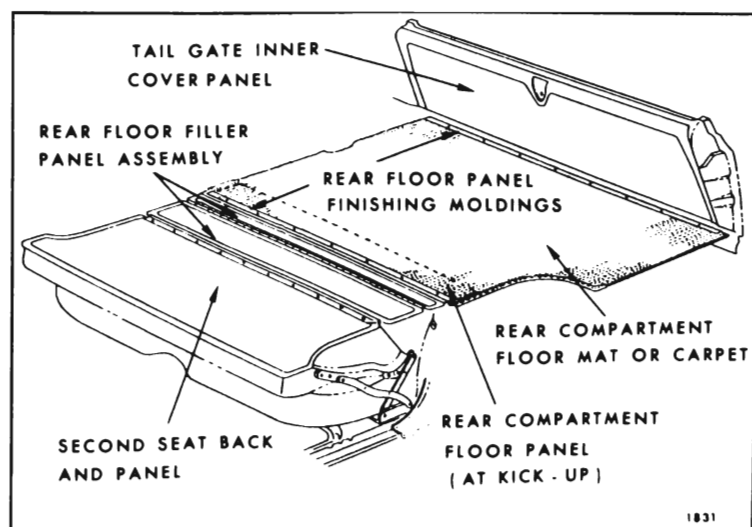

Fig. 10-63—Folding Second Seat and Rear Floor Panel Covering

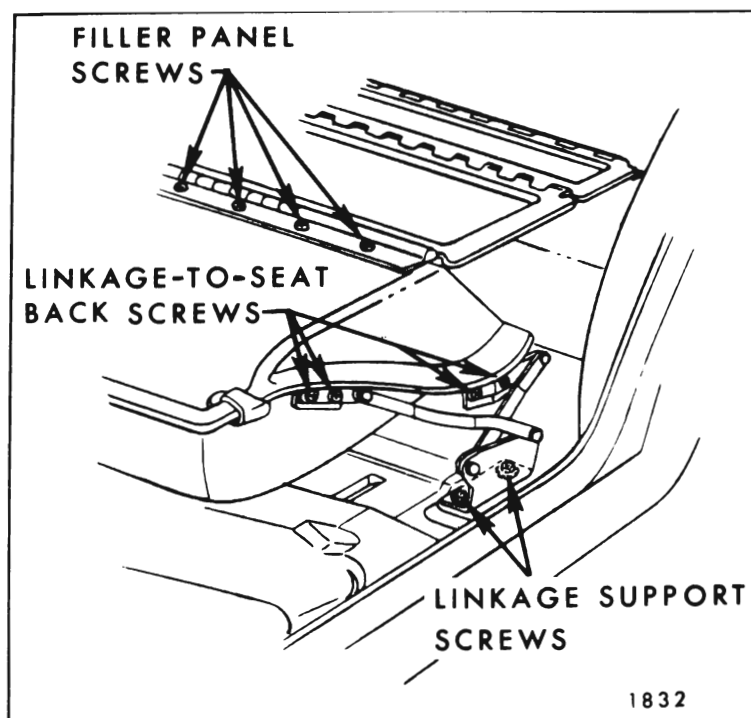

Fig. 10-64—Folding Second Seat Back Linkage and Filler Panel

FOLDING REAR SEAT BACK TRIM AND SPRING ASSEMBLY TWO-SEAT STYLES

Removal and Installation

1. Remove second seat cushion.
2. With folding second seat back in up position, remove screws along bottom edge of seat back trim. Lift trim and spring assembly to disengage retainers at top from slots in seat back panel; then, remove seat back trim and spring assembly from seat back panel.
3. To install, reverse removal procedure.

REAR COMPARTMENT FLOOR PANEL (AT KICK-UP) TWO-SEAT STYLES

Removal and Installation

1. Turn back front edge of rear compartment floor panel covering and remove eight hex-head rear compartment floor panel attaching screws. On styles with carpet, remove front finishing molding prior to turning back carpet.

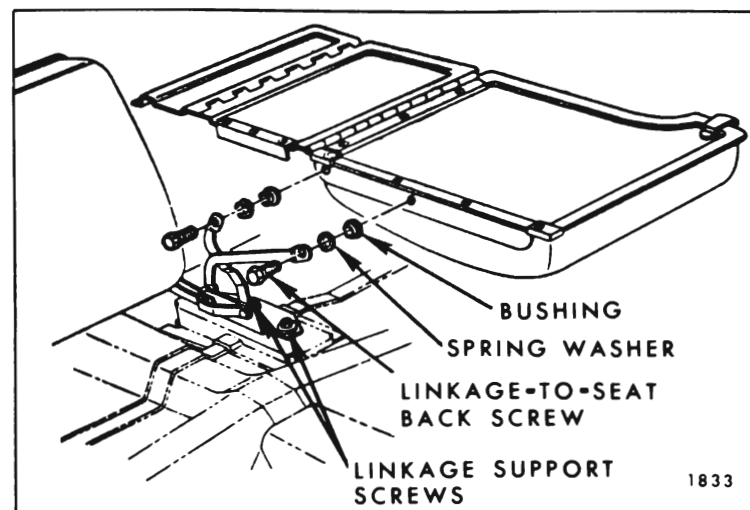

Fig. 10-65—Split Second Seat Center Linkage

2. To install, reverse removal procedure.

FOLDING REAR SEAT BACK AND PANEL ASSEMBLY TWO-SEAT STYLES

Removal and Installation

1. With second seat back in down position, remove screws securing rear floor filler panel to second seat back panel and detach filler panel from seat back.
2. On both sides of seat back, remove screws securing seat back to folding linkage (Fig. 10-64) and remove seat back and panel assembly from body.

See Figure 10-65 for center linkage attachments on split second seat.

3. To install, reverse removal procedure.

REAR FLOOR FILLER PANEL ASSEMBLY

Removal and Installation

1. Remove rear compartment floor panel (at kick-up) as previously described.
2. Remove filler panel front and rear attaching screws and remove filler panel assembly.
3. To install, reverse removal procedure.

STATION WAGON FOLDING SEATS AND FLOOR PANELS—"A" BODY "55 AND 65" STYLES

DESCRIPTION

The "55" Style Skylight station wagons have a full width folding second seat on which the seat back

folds flush with the floor panels. A luggage compartment is provided under the luggage compartment floor panel. Fig. 10-66 identifies the major load floor panels on the "55" Style station wagon.

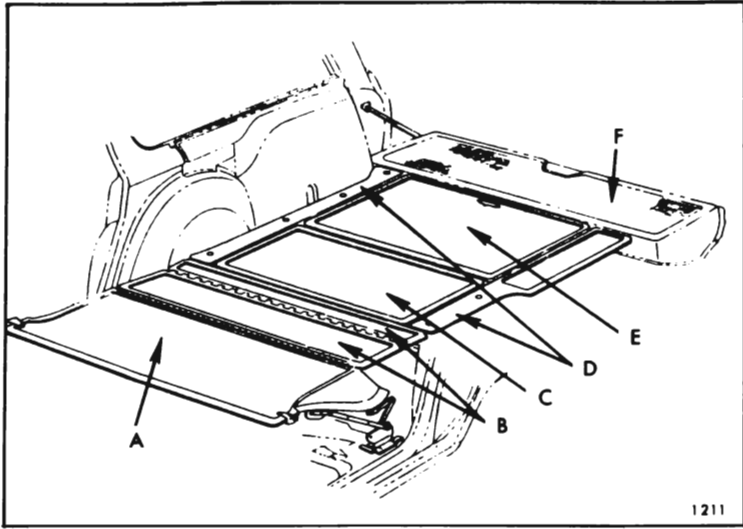

Fig. 10-66—Folding Seat and Rear Compartment Floor Panels "A-55" Style Station Wagon

- A. Folding Second Seat Back Panel
- B. Rear Floor Filler Panel Assembly
- C. Rear Compartment Floor Panel
- D. Rear Compartment Side Pan Cover Panel - Right and Left
- E. Luggage Compartment Cover Panel
- F. Tail Gate Inner Cover Panel

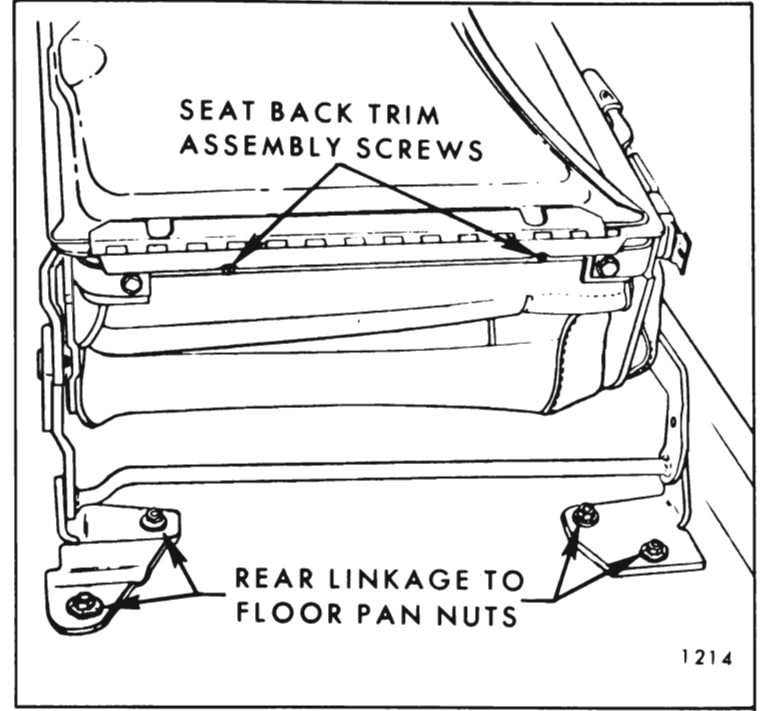

Fig. 10-68—Folding Second Seat Rear Linkage

The "65" Style station wagons have a full folding split second seat - 1/3 (right side), 2/3 (left side).

Both sections of the folding second seat are hinged to the floor pan and can be folded forward to provide entrance room into the third seat area. Also both sections of the folding second seat back can be folded flush with the floor panels. A seat back lock located at the outer linkage of both right and left folding second seat backs, locks the seat backs in the up position and must be released to fold the seats.

The full 3/4 width folding third seat is provided with an over-center lock on the right side linkage.

The lock handle is depressed to lock the seat in the

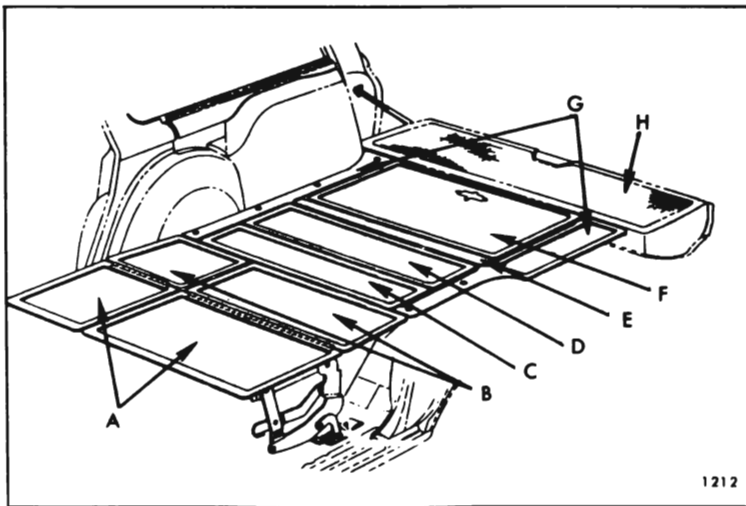

Fig. 10-67—Folding Seats and Rear Compartment Floor Panels "A-65" Style Station Wagon

- A. Folding Second Seat Back Panel - Left and Right
- B. Rear Floor Filler Panel - Left and Right
- C. Rear Floor Filler (at Kick-Up) Panel
- D. Folding Third Seat Back Panel Assembly
- E. Luggage Compartment Filler Panel
- F. Luggage Compartment Cover Panel
- G. Compartment Side Pan Cover Panel - Right and Left
- H. Tail Gate Inner Cover Panel

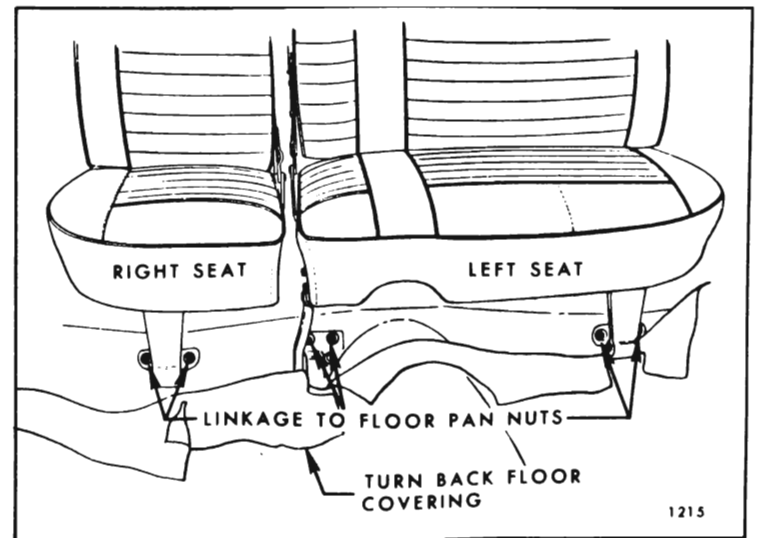

Fig. 10-69—Folding Second Seat Front Linkage

up position and pulled forward to release the lock and allow the seat to be folded.

Figure 10-67 identifies the major load floor panels on the "65" Style Skylight station wagon.

FOLDING SECOND SEAT ASSEMBLY— RIGHT OR LEFT SEAT "65" STYLES

Removal and Installation

1. Remove rear door sill plate and turn back floor carpeting sufficiently to gain access to nuts securing folding seat front and rear linkage to floor pan (Fig. 10-68 and 10-69).
2. Mark position of seat front and rear linkage supports on floor pan to facilitate installation of seat in same position.
3. Remove nut and washer assemblies securing front and rear linkage to floor pan (Fig. 10-68

and 10-69); then, remove seat assembly from body.

4. To install seat assembly, reverse removal procedure. Align linkage floor pan supports with previously made marks prior to tightening nuts.

FOLDING SECOND SEAT CUSHION ASSEMBLY—RIGHT OR LEFT SIDE "65" STYLES

Removal and Installation

1. Remove folding second seat assembly from car, as previously described and place on a clean surface.
2. Remove hog rings and detach outboard rear portion of trim sufficiently to remove three screws securing seat outer link to cushion frame (Fig. 10-70).

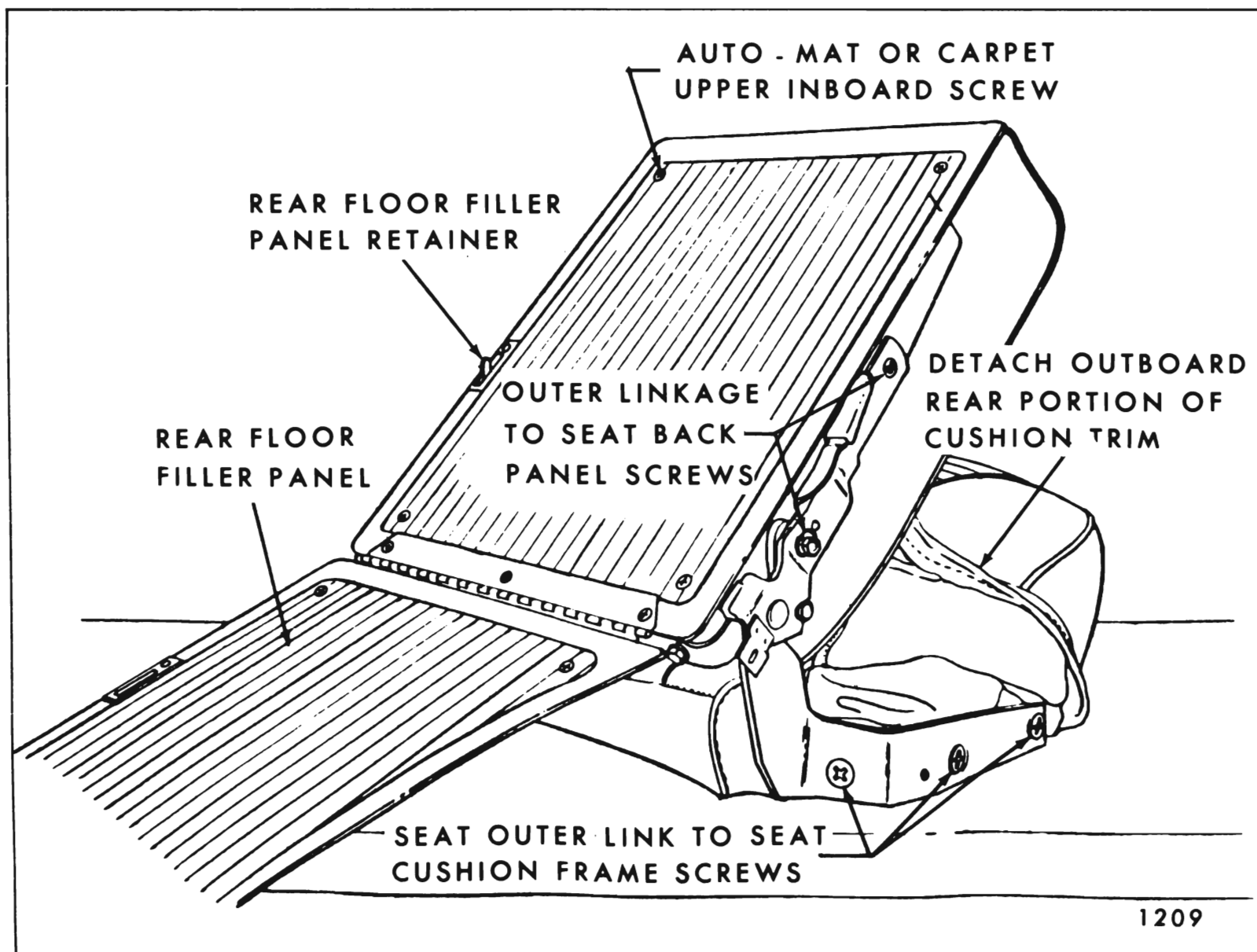

Fig. 10-70—Folding Second Seat Outer Linkage

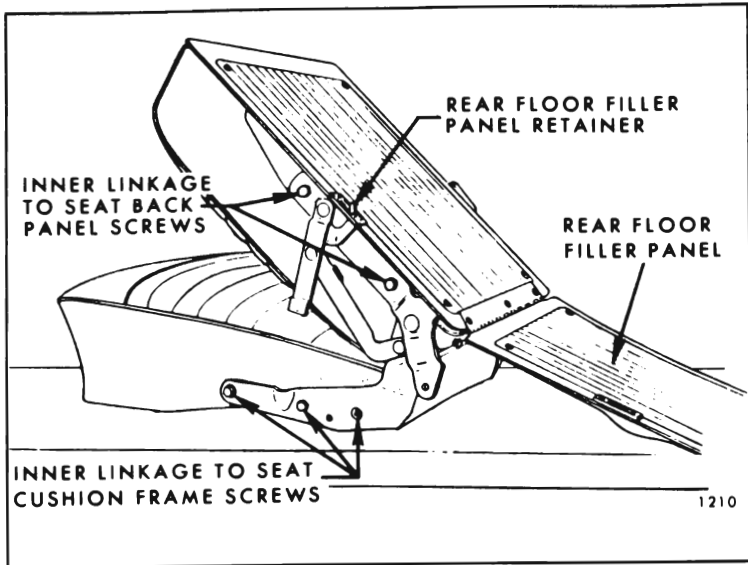

Fig. 10-71—Folding Second Seat Inner Linkage

3. Remove three screws securing seat inner link to cushion frame (Fig. 10-71); then remove seat cushion and frame assembly from linkage. If required, remove cushion front and rear floor pan linkage.
4. To install, reverse removal procedure.

FOLDING SECOND SEAT BACK TRIM AND SPRING ASSEMBLY—RIGHT OR LEFT SEAT “65” STYLES

Removal and Installation

1. Fold second seat back forward.
2. Remove seat back trim assembly attaching screws. (see Fig. 10-68).
3. Raise seat back; then, pull seat back trim assembly upward to disengage wire loops at top of seat back trim from slots in seat back panel.

NOTE: If seat back trim does not readily disengage from seat back panel, fold rear floor filler panel down and remove upper inboard screw securing automat or carpet (Fig. 10-70). Then remove seat back trim assembly.

4. To install seat back trim assembly, reverse removal procedure.

FOLDING SECOND SEAT FRONT FLOOR PAN LINKAGE—RIGHT OR LEFT SEAT “65” STYLES

Removal and Installation

1. Place seat in an up position. Turn back floor carpet sufficiently to gain access to front linkage floor pan attaching nuts.

2. Mark location of front linkage support on floor pan to facilitate installation in same position. Support front of seat. Remove bolts securing linkage to seat and nuts securing linkage to floor pan studs (see Fig. 10-69); then, remove front linkage.
3. To install, reverse removal procedure making sure linkage support on floor pan is aligned with previously made alignment mark.

FOLDING SECOND SEAT REAR FLOOR PAN LINKAGE—RIGHT OR LEFT SEAT “65” STYLES

Removal and Installation

1. Remove folding second seat assembly from car as previously described and place on a clean surface.
2. Remove screws securing rear floor pan linkage to each side of seat cushion frame (Fig. 10-72); then, remove linkage assembly from seat.
3. To install, reverse removal procedure. Inserts in Figure 10-72 show relationship of linkage, bushings and attaching screws.

FOLDING SECOND SEAT SIDE INNER LINKAGE—RIGHT OR LEFT SEAT “65” STYLES

Removal and Installation

1. Remove folding second seat assembly from car as previously described and place on a clean surface.

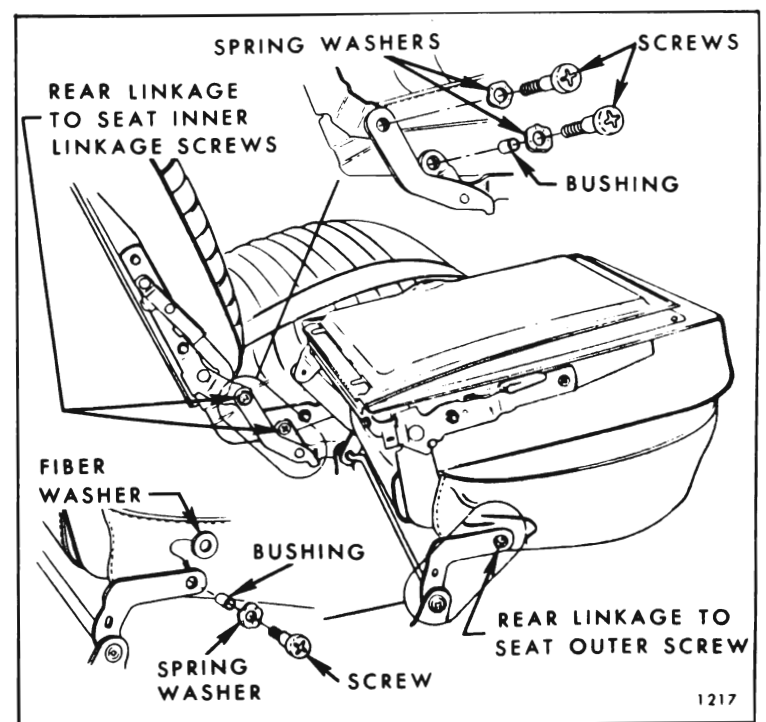

Fig. 10-72—Floor Pan Rear Linkage

2. Remove floor pan rear linkage-to-seat inner linkage attaching screws (Fig. 10-72).
3. Remove seat inner linkage-to-seat back panel and seat cushion frame attaching screws (see Fig. 10-71); then, disengage and remove side linkage from seat.
4. To install, reverse removal procedure. Make sure rear floor filler panel retainer is inserted through slot in seat back panel prior to installing inner linkage-to-seat back panel attaching screws.

FOLDING SECOND SEAT SIDE OUTER LINKAGE—RIGHT OR LEFT SEAT “65” STYLES

Removal and Installation

1. Remove folding second seat assembly from car as previously described and place on a clean surface.
2. Remove outer linkage cover. Remove screw securing seat rear floor pan linkage to seat outer attaching screw (Fig. 10-72).
3. Remove hog rings and detach rear portion of trim sufficiently to remove three screws securing outer linkage to seat cushion frame. (See Fig. 10-70).
4. Remove outer linkage-to-seat back panel attaching screws (see Fig. 10-70); then, remove linkage and seat back catch from seat.
5. To install, reverse removal procedure. Install seat back lock and spring as described under “Folding Second Seat Back Lock - Removal and Installation”.

FOLDING SECOND SEAT BACK LOCK—RIGHT OR LEFT SEAT “65” STYLES

Removal

1. Remove seat back trim assembly, as previously described. Remove outer linkage cover.
2. Remove outer linkage-to-seat back panel attaching screws (See Fig. 10-70).
3. Remove lock handle, spring and bushing from linkage.

Installation

1. Position bushing and spring on lock handle.
2. Install lock handle, bushing and spring into position between seat back panel and outer

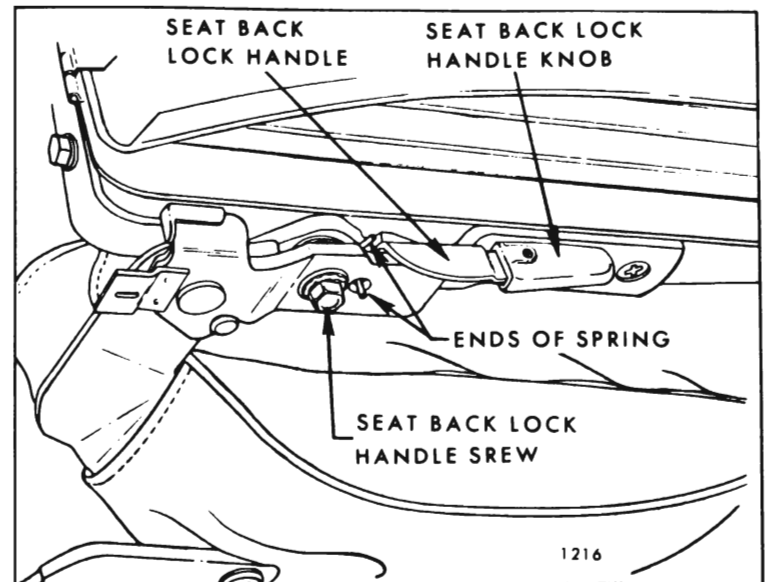

Fig. 10-73—Seat Back Lock

linkage making sure end of spring is engaged in hole in outer link (Fig. 10-73).

3. Install lock handle attaching screw; then, install outer linkage to seat back panel attaching screws (Fig. 10-70).
4. Install seat back trim assembly and outer linkage cover.

FOLDING SECOND SEAT BACK PANEL AND FILLER PANEL—RIGHT OR LEFT SEAT—“65” STYLES

Removal and Installation

1. Remove seat back trim assembly, as previously described. Remove outer linkage cover.

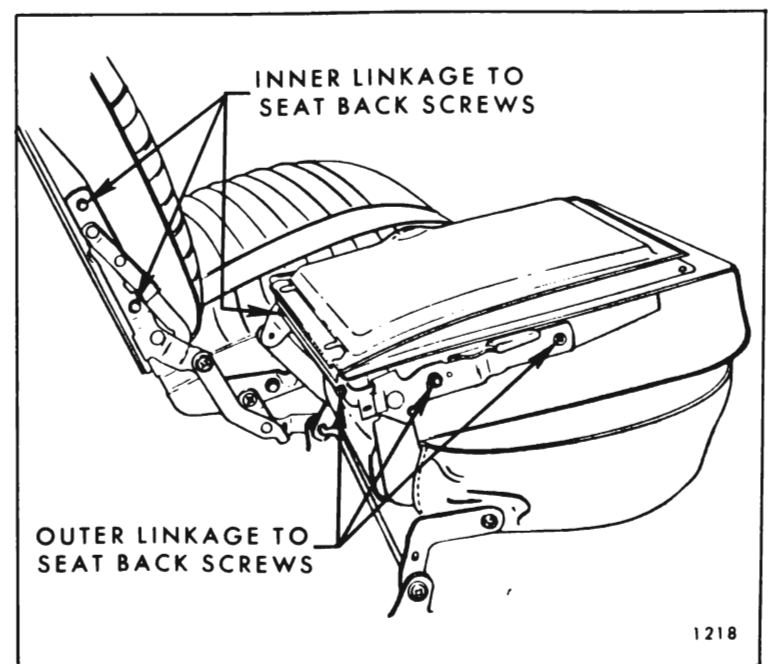

Fig. 10-74—Seat Inner and Outer Linkage

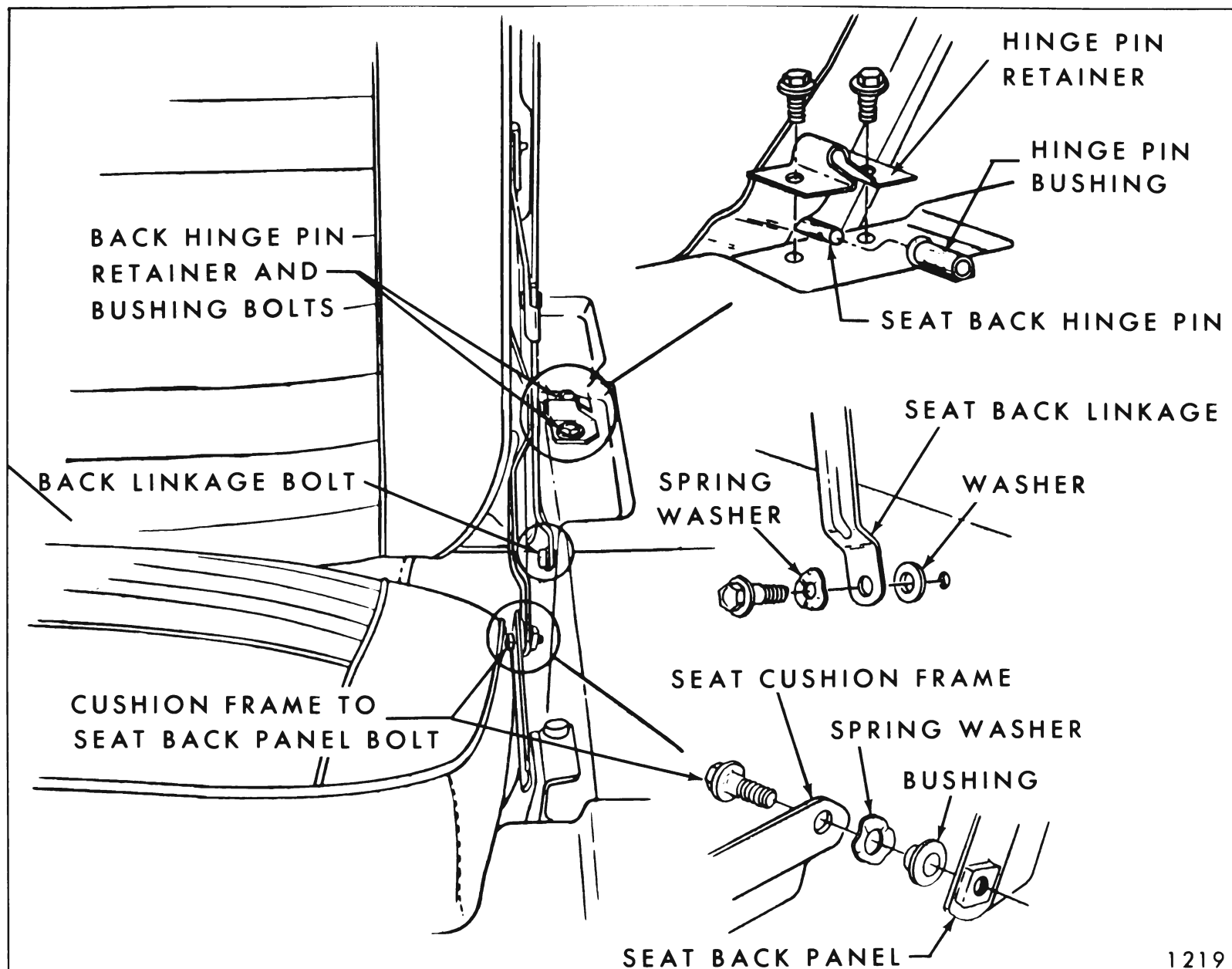

Fig. 10-75—Folding Third Seat

2. Remove outer and inner linkage to seat back attaching screws (Fig. 10-74). Remove seat back lock handle, spring and bushing from between outer linkage and seat back panel; then, remove seat back panel and rear floor filler panel from linkage.

3. To install, reverse removal procedure. To install seat back lock refer to "Folding Second Seat Back Lock - Installation".

FOLDING THIRD SEAT AND FLOOR PANEL ASSEMBLY "65" STYLES

Removal and Installation

1. Raise folding third seat. Remove rear compartment left side panel. (See Fig. 10-67).

2. Remove seat back linkage-to-compartment side pan attaching bolt (Fig. 10-75) at both right and left sides of seat.

3. At left side of seat remove seat back hinge pin retainer (Fig. 10-75).

4. Carefully move seat back assembly to the left sufficiently to disengage right seat back hinge pin from hinge pin retainer; then, remove folding third seat assembly from body and place on a clean surface.

5. To install folding third seat and floor panel assembly, reverse removal procedure. Make sure a seat back hinge pin bushing is installed over both hinge pins. Also install flat washer between seat back linkage and compartment side pan and spring washer between linkage and bolt head (Fig. 10-75).

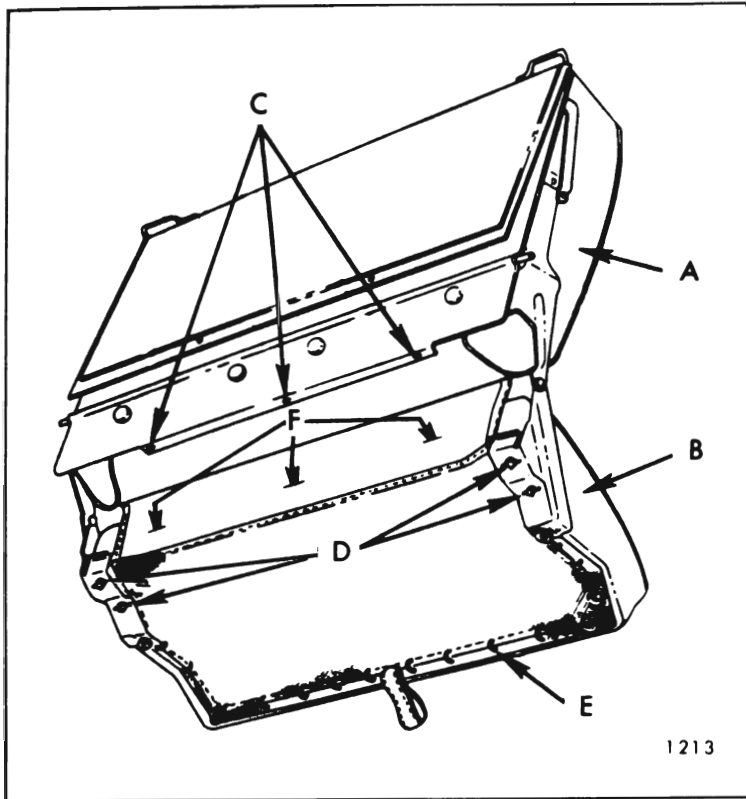

Fig. 10-76—Folding Third Seat Assembly

- | | |
|---|---|
| A. Third Seat Back | E. Hog Rings Securing Seat Back Trim Flap |
| B. Third Seat Cushion | F. Location of Cushion Trim to Cushion Frame Attaching Screws (Under Trim Flap) |
| C. Seat Back Trim to Seat Back Panel Attaching Screws | |
| D. Cushion Trim to Cushion Frame Attaching Screws | |

FOLDING THIRD SEAT CUSHION TRIM ASSEMBLY "65" STYLES

Removal and Installation .

1. Raise folding third seat. Raise front of third seat cushion and prop in up position.
2. Remove hog rings securing seat back trim flap to bottom of seat cushion (Fig. 10-76).
3. Remove seat cushion frame-to-seat back panel attaching bolt (Fig. 10-75) from both sides of seat; then, remove seat cushion assembly and place on a clean surface.
4. As a bench operation remove hex-head screws securing seat cushion trim to seat cushion

frame (Fig. 10-76) and three screws securing rear edge of seat cushion trim to seat cushion frame; then, remove cushion trim assembly from cushion frame.

5. To install, reverse removal procedure. When installing seat cushion frame-to-seat back frame attaching bolts install bolt bushing and spring washer, as shown in insert of Figure 10-75.

FOLDING THIRD SEAT BACK TRIM ASSEMBLY OR SEAT BACK PANEL ASSEMBLY "65" STYLES

Removal and Installation

1. Remove folding third seat and floor panel assembly, as previously described, and place on a clean surface.
2. Remove hog rings securing seat back trim flap to bottom of seat cushion (Fig. 10-76).
3. To remove seat back trim assembly remove seat back trim-to-seat back panel attaching screws (Fig. 10-76); then, lift trim assembly upward to disengage wire loops on seat back trim from slots in seat back panel and remove trim assembly.
4. To remove seat back panel assembly, remove seat cushion frame-to-seat back panel attaching bolt (Fig. 10-75); then, remove seat back panel with attached rear floor filler (at kick-up) panel from seat cushion.
5. To install, reverse removal procedure. Refer to inserts in Figure 10-75 for correct installation of linkage bolts, bushings and spring washers.

LUGGAGE COMPARTMENT COVER PANEL AND FILLER PANEL "65" STYLES

Removal and Installation

1. Raise luggage compartment cover panel and support cover panel in up position.
2. Remove five hex-head screws securing cover panel to cross bar; then remove luggage compartment cover panel and filler panel.
3. To install, reverse removal procedure.

SEAT BELTS

FRONT STANDARD SEAT BELTS

Removal and Installation

1. Remove bolt on outboard seat belt anchor plate at rocker inner panel and inboard seat belt anchor plate on side of floor pan tunnel. (See Fig. 10-77).

2. Bench Type Seats Only: Pull inboard belt from front of seat thru protector, and from between front seat cushion and back (Fig. 10-78).
3. To install, reverse removal procedure, making certain that anchor plates are facing direction of seat belt pull.

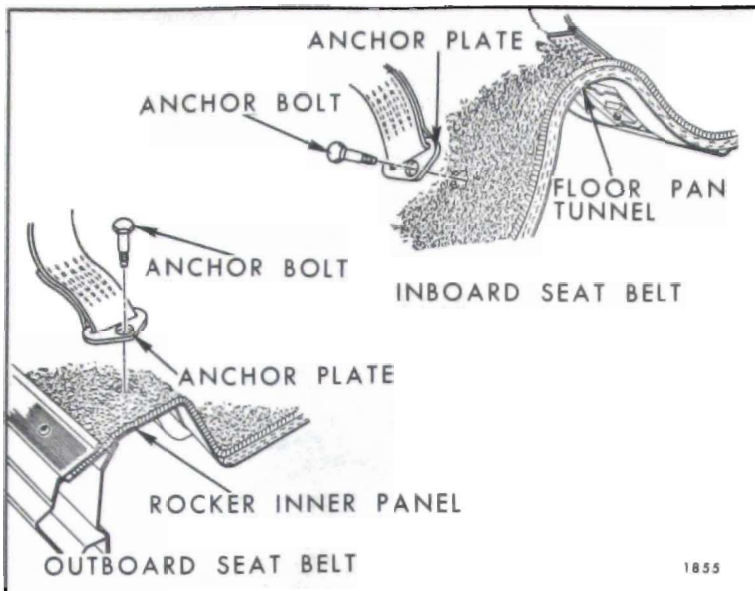

Fig. 10-77—Standard Seat Belt Attachments

FRONT DELUXE SEAT BELTS WITH BAIL TYPE RETRACTORS

Description

As an option, seat belts are available with bail type seat belt retractors on the outboard belt only. The outboard seat belt must be fully extended and the inboard belt adjusted for individual requirements when the seat belt is fastened by the driver or passenger. When the seat belt buckle is operated to disengage the belts, the outboard belt will automatically retract to the floor pan.

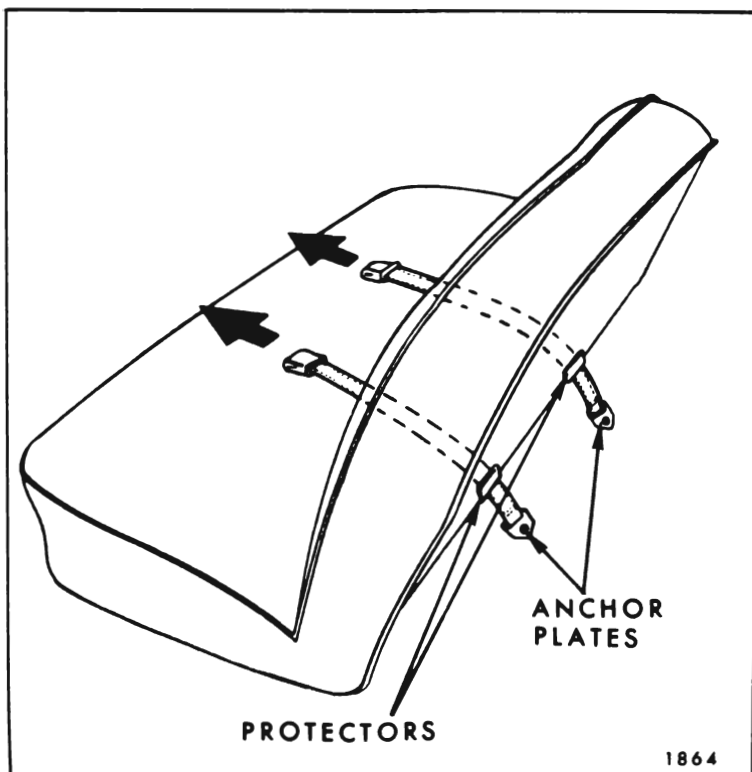

Fig. 10-78—Removal of Seat Belts from Bench Type Seats

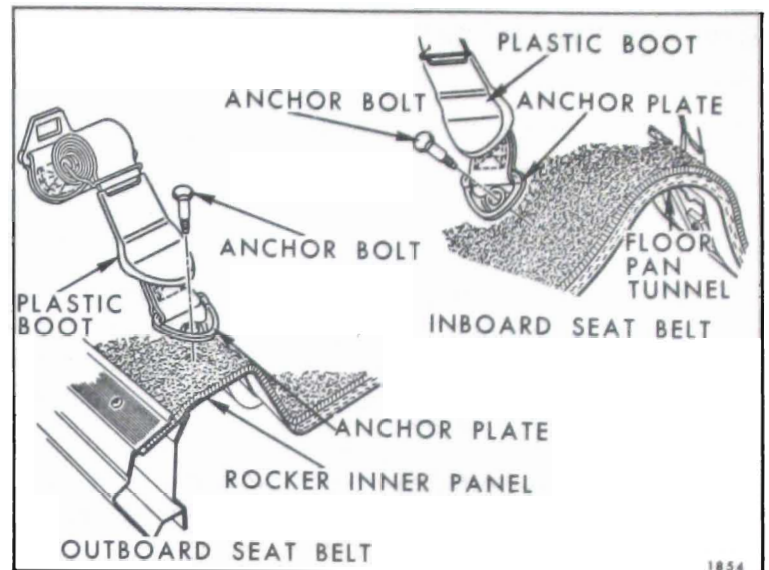

Fig. 10-79—Deluxe Seat Belt Attachments - With Bail Type Retractors

Deluxe Seat Belts with Bail Type Retractors

Removal and Installation

1. Remove bolt on outboard seat belt anchor plate at inner rocker panel and inboard seat belt anchor plate on side of floor pan tunnel by first sliding plastic boot away from plates (See Fig. 10-79).
2. Bench Type Seats Only: Pull inboard seat belt from front of seat thru protector and from between front seat cushion and back (See Fig. 10-78).
3. To install, reverse removal procedure, making certain that anchor plates are facing direction of seat belt pull.

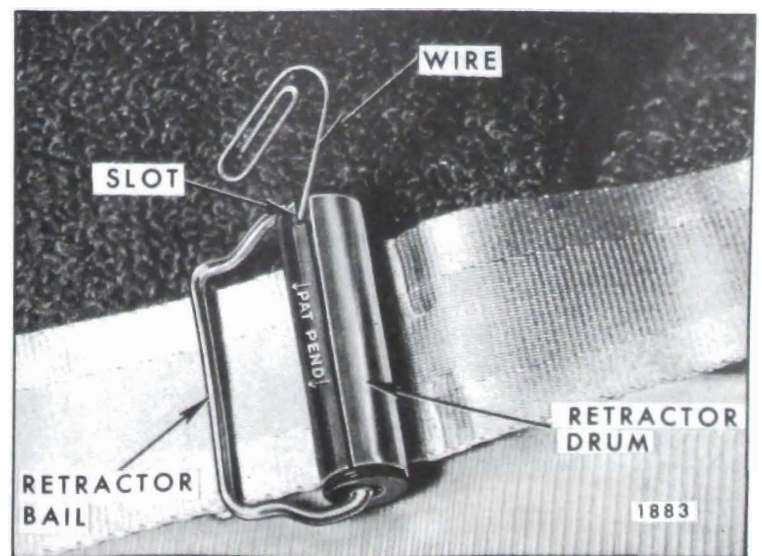

Fig. 10-80—Locking Seat Belt Bail Type Retractor Drum

Bail Type Retractor

Removal

1. Extend outboard seat belt to full length.
2. Insert a piece of stiff wire such as a paper clip in slot in roller drum to maintain spring tension of retractor. (See Fig. 10-80).

IMPORTANT: Wire to remain in slot until retractor is reinstalled. In the event that spring tension is lost, drum on retractor can be turned 8 revolutions by hand to regain spring tension.

3. Using a flat-bladed tool pry open tabs that secure belt on drum and remove retractor from belt (See Fig. 10-81).

Installation

1. With seat belt fully extended, insert belt under tabs on retractor and position on center of seat belt.

NOTE: Tabs on retractor to be on inboard side of seat belt and bail pointing forward.

2. Using pliers, lightly bend down tabs securing belt to drum.
3. Remove wire from slot in drum (when replacing with new retractor, a retaining clip that retains spring tension will be on retractor which is to be removed) and allow belt to roll up on retractor.

FRONT DELUXE SEAT BELTS WITH FLOOR MOUNTED RETRACTOR AND COVER

Description

As an option, seat belts may be equipped with seat

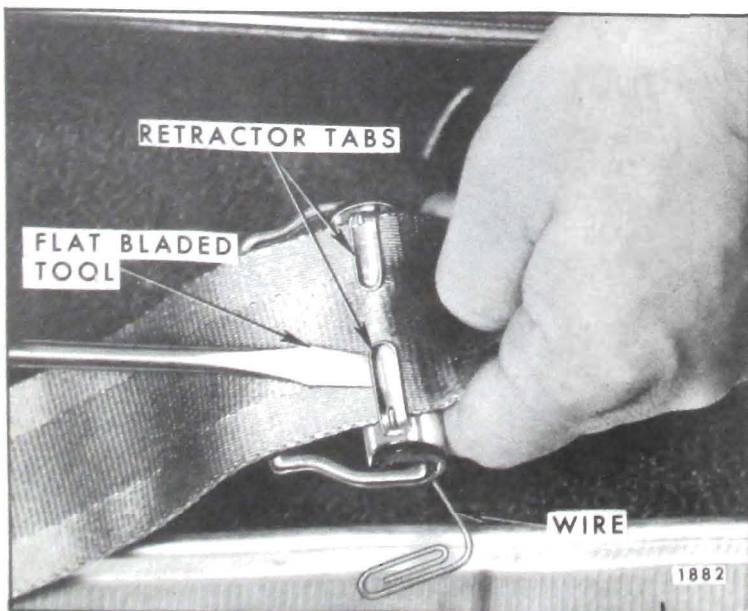

Fig. 10-81—Removal of Bail Type Retractor from Seat Belt

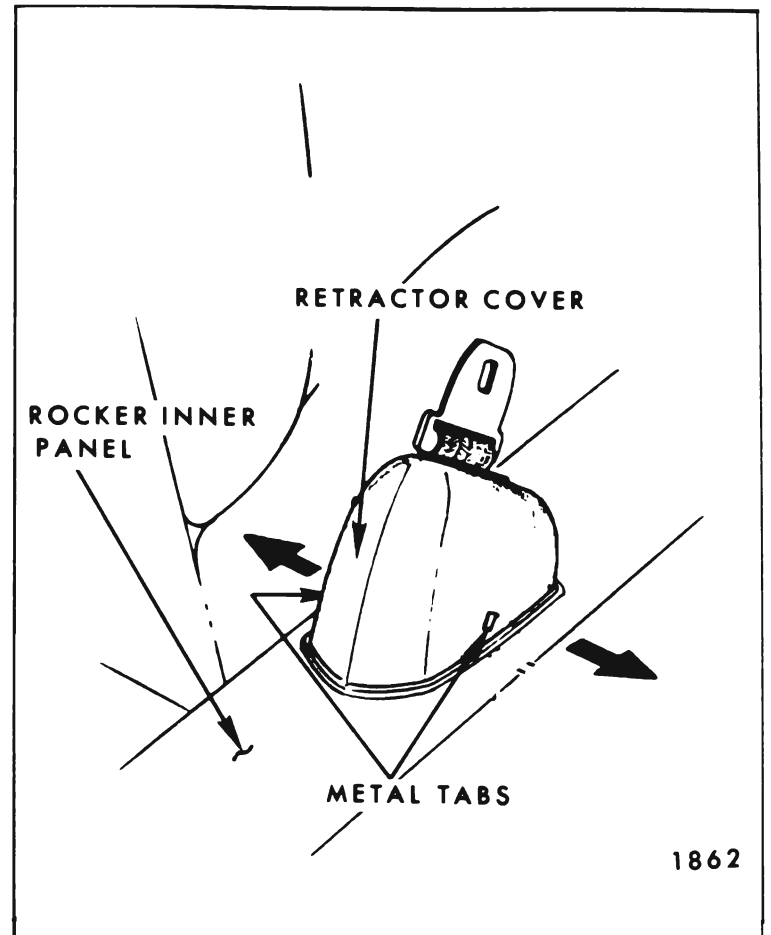

Fig. 10-82—Removal of Seat Belt Retractor Cover

belt floor mounted retractor and covers on the outboard side only. The outboard seat belt must be fully extended and the inboard belt adjusted for individual requirements when the seat belt is fastened by the driver or passenger. When the seat belt buckle is operated to disengage the belts; the outboard belt will automatically retract into the retractor cover.

Outboard Seat Belt

Removal

1. Extend belt fully; insert screwdriver through belt opening in cover and apply moderate pressure to inside of cover adjacent to metal tabs and disengage cover from tabs on sides of retractor base. (See Fig. 10-82)
2. Lift up cover to expose bolt securing seat belt retractor (See Fig. 10-83).
3. Remove bolt and remove retractor (See Fig. 10-83).

Installation

1. With retractor cover disengaged insert bolt thru retractor and into top of rocker inner panel and secure.

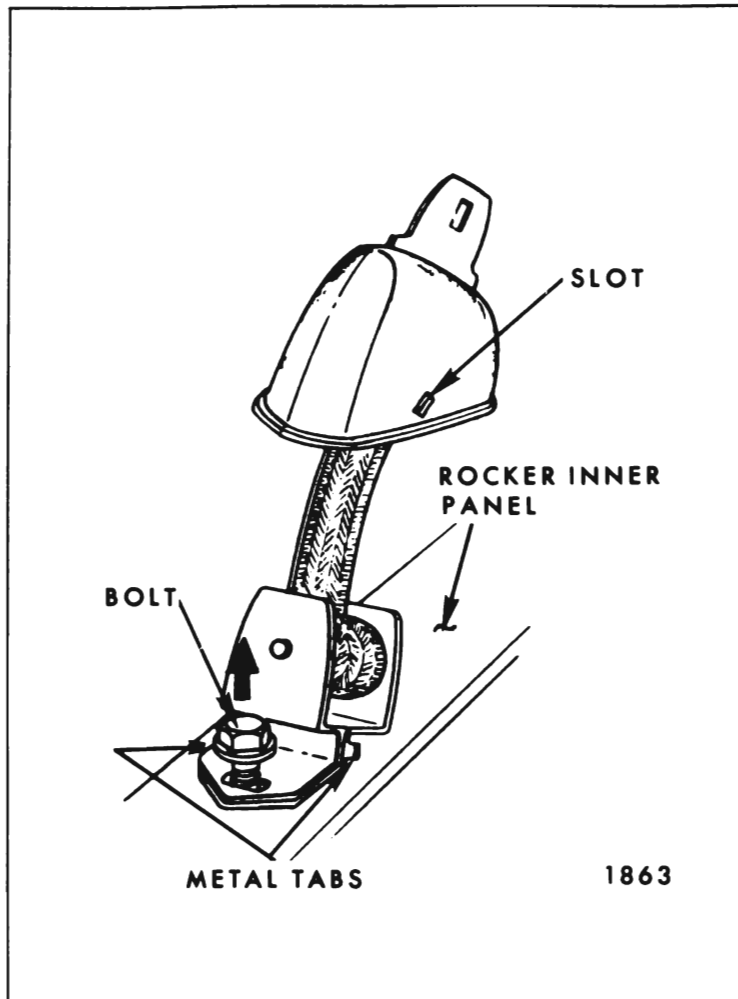

Fig. 10-83—Removal of Seat Belt Retractor with Cover

2. Gently pull sides of retractor cover outward, and position cover on retractor snapping slots in cover over metal tabs on retractor.

NOTE: Seat belt retractor and seat belt is serviced only as an assembly.

Inboard Seat Belt—Bucket Seats

Removal and Installation

1. Remove bolt securing seat belt anchor plate from side of floor pan tunnel. (See Fig. 10-77)

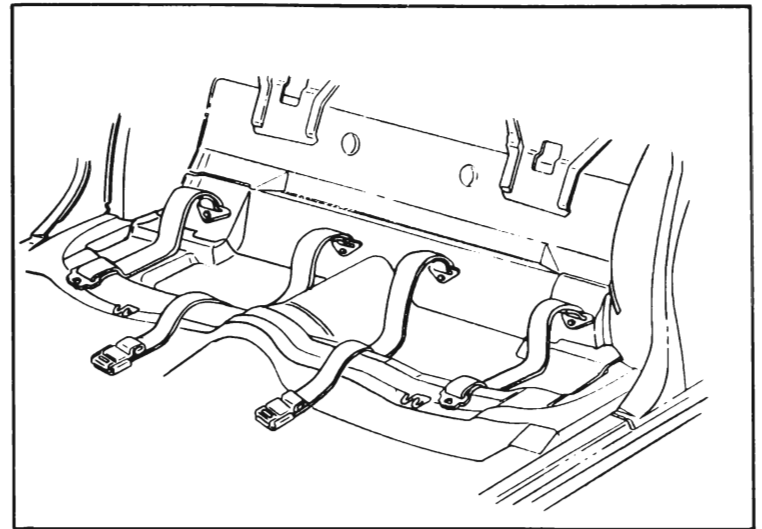

Fig. 10-84—Rear Seat Belt Attachment

2. To install, reverse removal procedure.

Inboard Seat Belts—Full Width Seats

Removal and Installation

1. Remove bolt securing seat belt anchor plate from side of floor pan tunnel. (See Fig. 10-77).
2. From front of seat, pull seat belt thru protector and from between front seat cushion and back (See Fig. 10-78).
3. To install, reverse removal procedure.

REAR SEAT BELTS

Rear seat belts will be available on all styles as standard equipment. The rear seat belts are attached to anchor nuts in the floor pan by bolts. To remove rear seat belts, remove rear seat cushion assembly, remove belt attaching bolts and seat belts. To install, reverse removal procedure making certain that the belts with the buckles are installed on the inboard location of the floor pan (Fig. 10-84).