

# SECTION 12

## EXTERIOR MOLDINGS

### INDEX

Subject	Page	Subject	Page
Introduction . . . . .	12-1	Molding Views and Charts-Oldsmobile . . . . .	12-44
General Precautions . . . . .	12-1	F-85-"A" (33000 Series) . . . . .	12-44
Sealing Operation . . . . .	12-1	Oldsmobile-"B & C" (35-38000 Series) . . . . .	12-52
Tools and Care . . . . .	12-3	Oldsmobile-"E" (39000 Series) . . . . .	12-61
Molding Views and Charts-Chevrolet . . . . .	12-4	Molding Views and Charts-Buick . . . . .	12-63
Corvaire-"Z" (10000 Series) . . . . .	12-4	Special-"A" (43-44000 Series) . . . . .	12-63
Chevy II-"X" (11000 Series) . . . . .	12-7	Buick-"B & C" (45-46-48000 Series) . . . . .	12-71
Chevelle-"A" (13000 Series) . . . . .	12-12	Buick-"E" (49000 Series) . . . . .	12-79
Chevrolet-"B" (15-16000 Series) . . . . .	12-20	Molding Views and Charts-Cadillac . . . . .	12-81
Molding Views and Charts-Pontiac . . . . .	12-27	Cadillac-"C" (68000 Series) . . . . .	12-81
Tempest-"A" (23-24000 Series) . . . . .	12-27		
Pontiac-"B" (25-26000 Series) . . . . .	12-35		

## EXTERIOR MOLDINGS

### INTRODUCTION

The exterior moldings are secured to the body by any one or a combination of the following attachments (see Fig. 12-1).

- a. attaching screws
- b. bolt and clip assemblies with attaching nuts
- c. integral studs with attaching nuts
- d. "bath-tub" type snap on clips
- e. "W base" type snap in clips
- f. weld on studs and clips
- g. snap in studs to pre-installed retainers
- h. spring (self retained)

Before using the molding charts the following information will be helpful when installing or removing exterior moldings.

1. Screw locations - the exact location for each screw is not shown or mentioned, but when hidden, the general location is indicated by naming the molding or other part which conceals the screw and therefore must be removed to gain access to the screw.
2. When a molding is overlapped the overlapping molding is indicated in the "Engages with other molding" column and must be removed first.

### GENERAL PRECAUTIONS

When removing or installing any body exterior molding certain precautions should be exercised.

1. Adjacent finishes should be protected with masking tape to prevent damage to finish.
2. Proper tools and care should be employed to guard against molding damage.

### SEALING OPERATION

Although detailed sealing operations for each individual molding are not described on the "Molding Removal Chart" the following information is given to permit a satisfactory sealing operation.

Medium-bodied sealer or body caulking compound are the sealers most frequently used to provide a watertight seal or for anti-rattle measures.

Holes in body panels for screws, bolts, or clips that would permit water to enter the interior of the body should be sealed with body caulking compound or presealed screws, nuts or clips.

Drip moldings require a 1/4" bead of medium-bodied sealer along the full length of the inner attaching surface. Door window scalps and center pillar scalps require a 1/8" x 1/4" x 1/4" bead of caulking compound at 5" intervals for anti-rattle purposes. Pinchwelds require medium-bodied sealer on both sides when pinchweld clips are used. The exception is the rear quarter pinchweld on convertible styles which requires waterproof tape over the entire pinchweld, prior to clip installation.

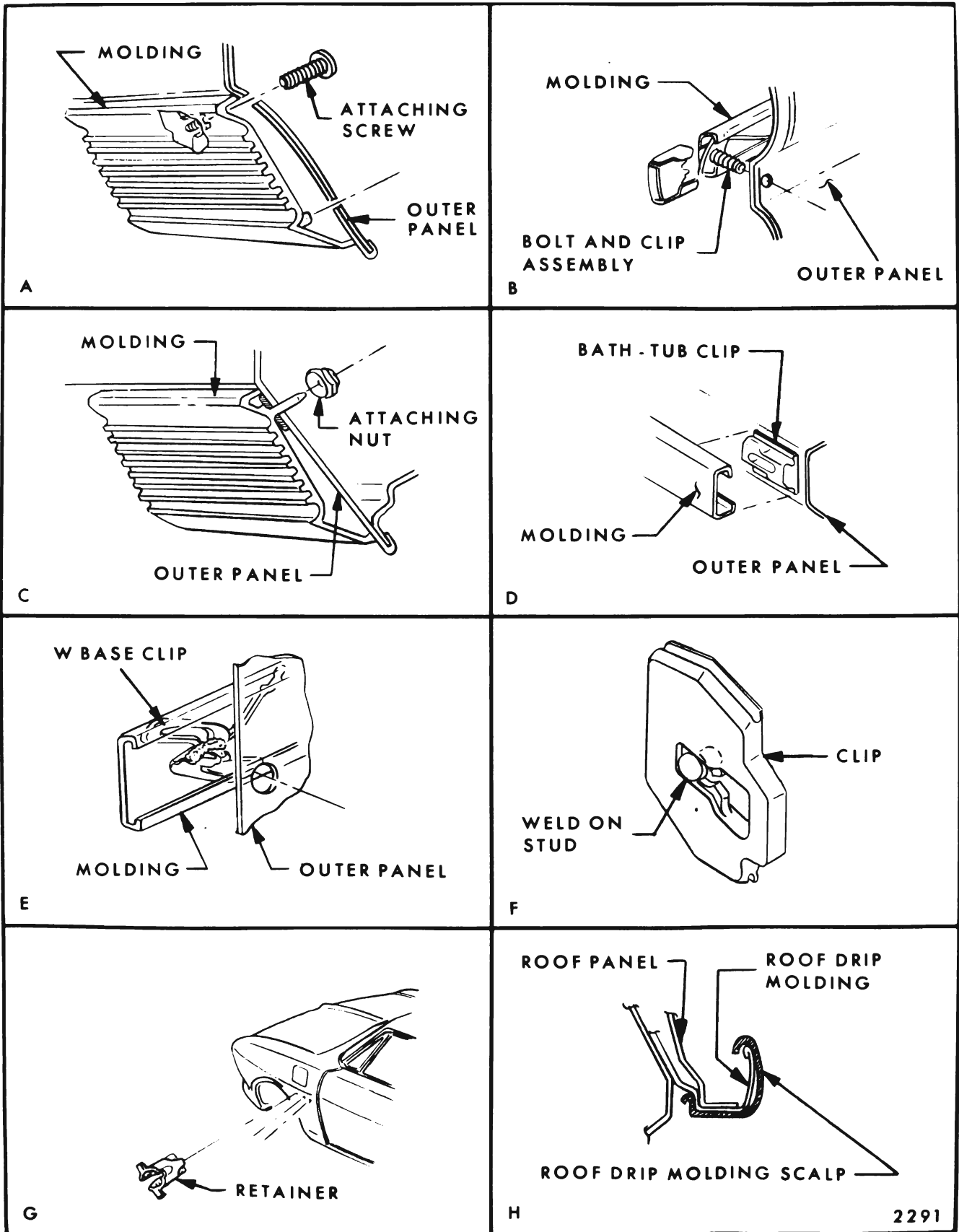

2291

Fig. 12-1—Exterior Molding Attachments

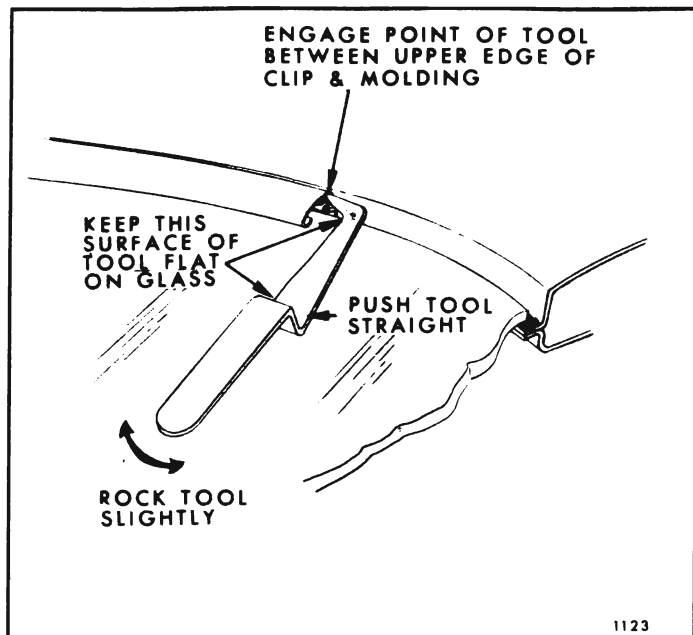

Fig. 12-2—Usage of Reveal Molding Disengagement Tool

## TOOLS AND CARE

The following groups of moldings are listed with the name or description of the tool which is suitable for molding removal.

Roof Drip Scalps - pointed hook tool

Door Window Scalps - thin flat-bladed tool (putty knife)

Snap-On Clips - thin flat-bladed tool (putty knife)

Reveal moldings around adhesive caulked glass installations are retained by clips which are attached to the body opening by weld on studs or screws. On all styles, a projection on the clip engages the reveal molding flange, retaining the molding between clip and body metal. To disengage a molding from retaining clips use tool J-21549-2 (or J-9698) or any other suitable tool as shown in Figure 12-2.

**NOTE:** Adhesive caulked window glass tool set J-21549-03 is available as a service tool package and consists of:

J-21549-1 Handle

\*J-21549-2 Reveal molding remover (flat blade)

\*\*J-21549-3 Reveal molding remover (angle blade)

J-21549-5 R.H. Reveal molding remover

J-21549-6 L.H. Reveal molding remover

\*also available as J-21549

\*\*also available as J-9698

If it is necessary to replace a damaged "bath-tub" molding clip, use the following procedure for removal and installation:

1. Insert sharp edge of flat-bladed tool, such as a putty knife, under edge of clip and hammer tool until base of clip is cut approximately half-way through (Fig. 12-3) then disengage clip from hole.

**NOTE:** In some cases, it may be necessary to cut clip at opposite end of base also.

2. Special tool J-21214 is required when installing metal bath-tub type clips.

3. No special tool is needed to install a new plastic bath-tub type clip.

If a weld stud on a panel becomes damaged or broken off use the following procedure:

1. Drill a small hole in the panel adjacent to where original weld on stud was installed.
2. Insert a self sealing screw through original clip and into outer panel.

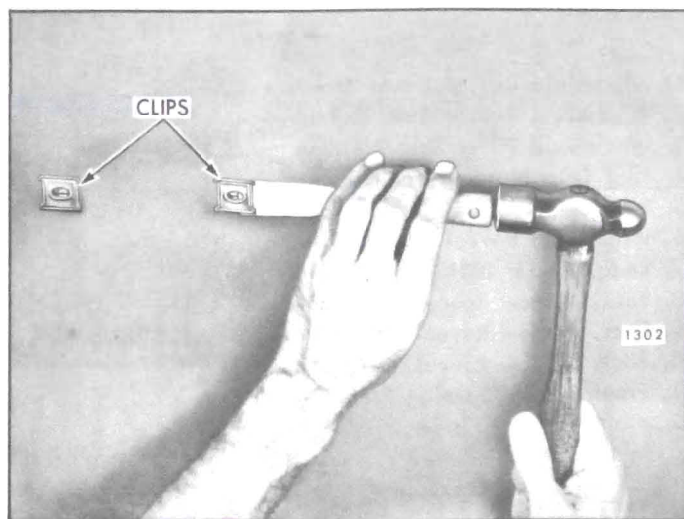

Fig. 12-3—Removal of "Bath-Tub" Molding Clip

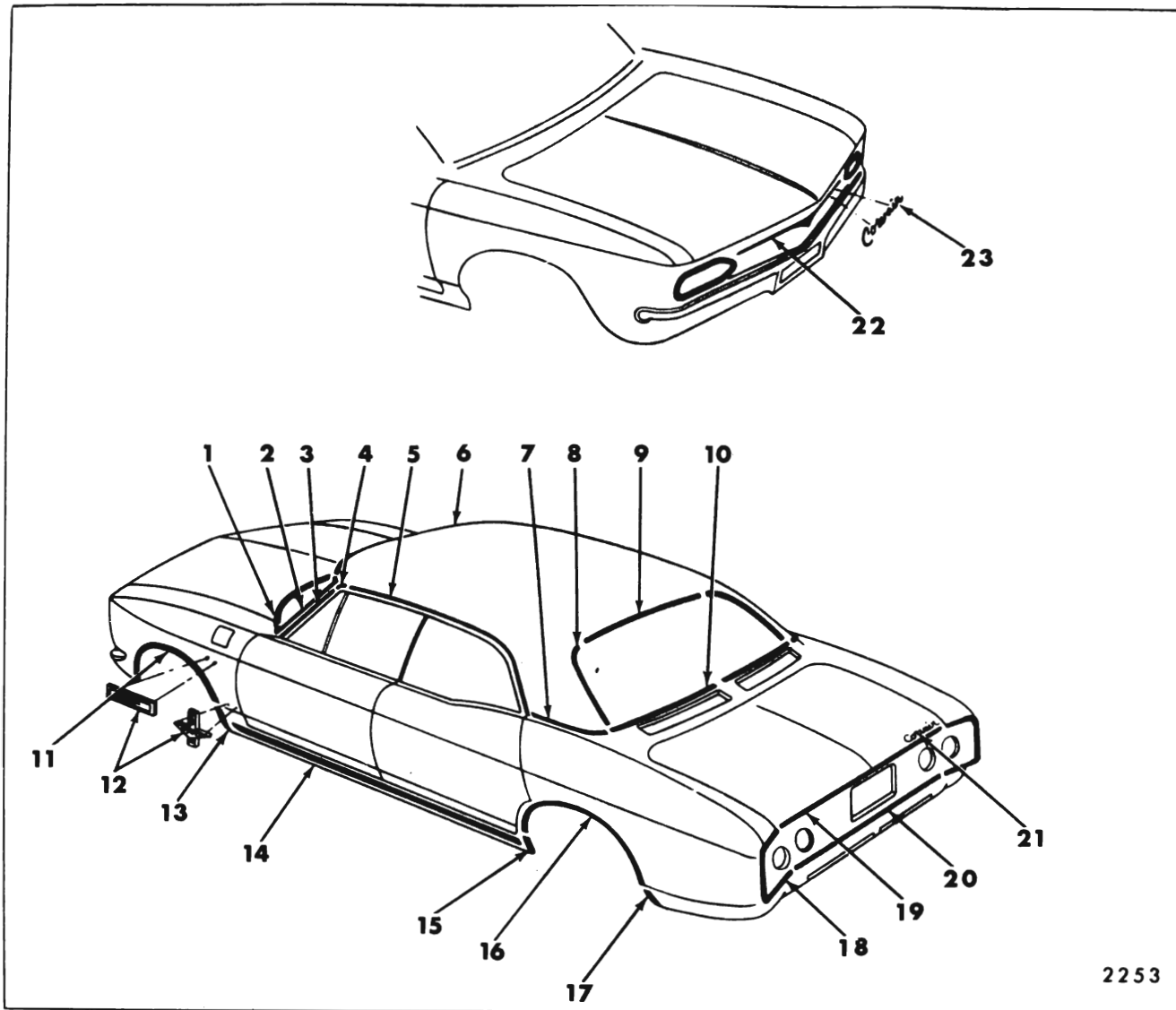

Fig. 12-4—Corvair - "Z-39" Styles

- |   |  |
|---|--|
| <ul style="list-style-type: none"> <li>1. Windshield Reveal Lower Molding</li> <li>2. Windshield Reveal Side Molding</li> <li>3. Windshield Pillar Drip Molding</li> <li>4. Roof Drip Molding Scalp Escutcheon</li> <li>5. Roof Drip Molding Scalp</li> <li>6. Windshield Reveal Upper Molding</li> <li>7. Rear Quarter Belt Reveal Molding</li> <li>8. Back Window Reveal Side Molding</li> <li>9. Back Window Reveal Upper Molding</li> <li>10. Back Window Reveal Lower Molding</li> <li>11. Front Wheel Opening Front Molding</li> <li>12. Front Fender Emblem</li> </ul> | <ul style="list-style-type: none"> <li>13. Front Wheel Opening Rear Molding</li> <li>14. Rocker Panel Molding</li> <li>15. Front of Rear Wheel Opening Molding</li> <li>16. Rear Wheel Opening Molding</li> <li>17. Rear of Rear Wheel Opening Molding</li> <li>18. Rear of Rear Quarter Panel Molding</li> <li>19. Engine Compartment Lid Outer Panel Molding</li> <li>20. Rear End Panel Molding</li> <li>21. Engine Compartment Lid Outer Panel Nameplate</li> <li>22. Front Compartment Emblem</li> <li>23. Front Compartment Nameplate</li> </ul> |
|---|--|

10100 - 10500 - 10700 SERIES

Molding Name	Series Or Styles	Method of Retention					Engages With Other Moldings	Remove Hardware Or Trim
		Screws	Spring (Self-Retained)	Snap-On Clips Or Retainers On Panel	Snap-On Clips On Moldings	Studs With Attaching Nuts		
Front End Outer Panel	All					X	Front Compartment Lock Cylinder and Retainer	
Front End Outer Panel Nameplate	All					X		
Front Wheel Opening Front	10500-10700	X						
Front Wheel Opening Rear	10500-10700	X					Loosen Front Wheel Opening Front Molding	
Front Fender Emblem	All			X		X	Front Cowl Trim Foundation	
Windshield Reveal Upper	All			X				
Windshield Reveal Side	All			X			Remove Windshield Upper Reveal	
Windshield Reveal Lower	All			X			Remove Windshield Side Reveal	
Windshield Pillar Drip	All (except 67)	X					Front Section of Side Roof Rail Weatherstrip and Weatherstrip Retainer	
Windshield Pillar Finishing	67 Style	X					Windshield Pillar Weatherstrip and Weatherstrip Retainer	
Windshield Pillar Drip Molding Scalp	10537, 39, 10737		X				Windshield Pillar Drip Molding Scalp Escutcheon	

10100 - 10500 - 10700 SERIES (Cont'd.)

Molding Name	Series Or Styles	Method of Retention						Engages With Other Moldings	Remove Hardware Or Trim
		Screws	Spring (Self-Retained)	Snap-On Clips Or Retainers On Panel	Snap-On Clips On Moldings	Studs With Attaching Nuts			
Windshield Pillar Drip Molding Scalp Escutcheon	10537, 39, 10737		X						
Roof Drip Molding Scalp	10537, 39, 10737		X					Windshield Pillar Drip Molding Scalp	
Rocker Outer Panel	10500-10700	X			X				
Rear Wheel Opening Front	10500-10700	X						Loosen Rear Wheel Opening Center	
Rear Wheel Opening Center	10500-10700	X							
Rear Wheel Opening Rear	10500-10700	X						Loosen Rear Wheel Opening Center	
Rear Quarter Outer Panel Emblem	10700						X		
Rear Quarter Belt Reveal (Optional)	39 Styles				X		X		
Rear Quarter Pinch Weld Finishing	67 Styles	X						Left Side Telescopes into Right Side	
Back Glass Reveal Upper	All 37-39 Styles				X			Remove Back Glass Reveal Sides	
Back Glass Reveal Side	All 37-39 Styles				X			Remove Back Glass Reveal Lower	
Back Glass Reveal Lower	All 37-39 Styles				X				
Rear of Rear Quarter	10500-10700								X
Engine Compartment Lid	10500-10700	X							X
Engine Compartment Lid Nameplate	All								X
Rear End Panel	10500-10700							Rear of Rear Quarter	X

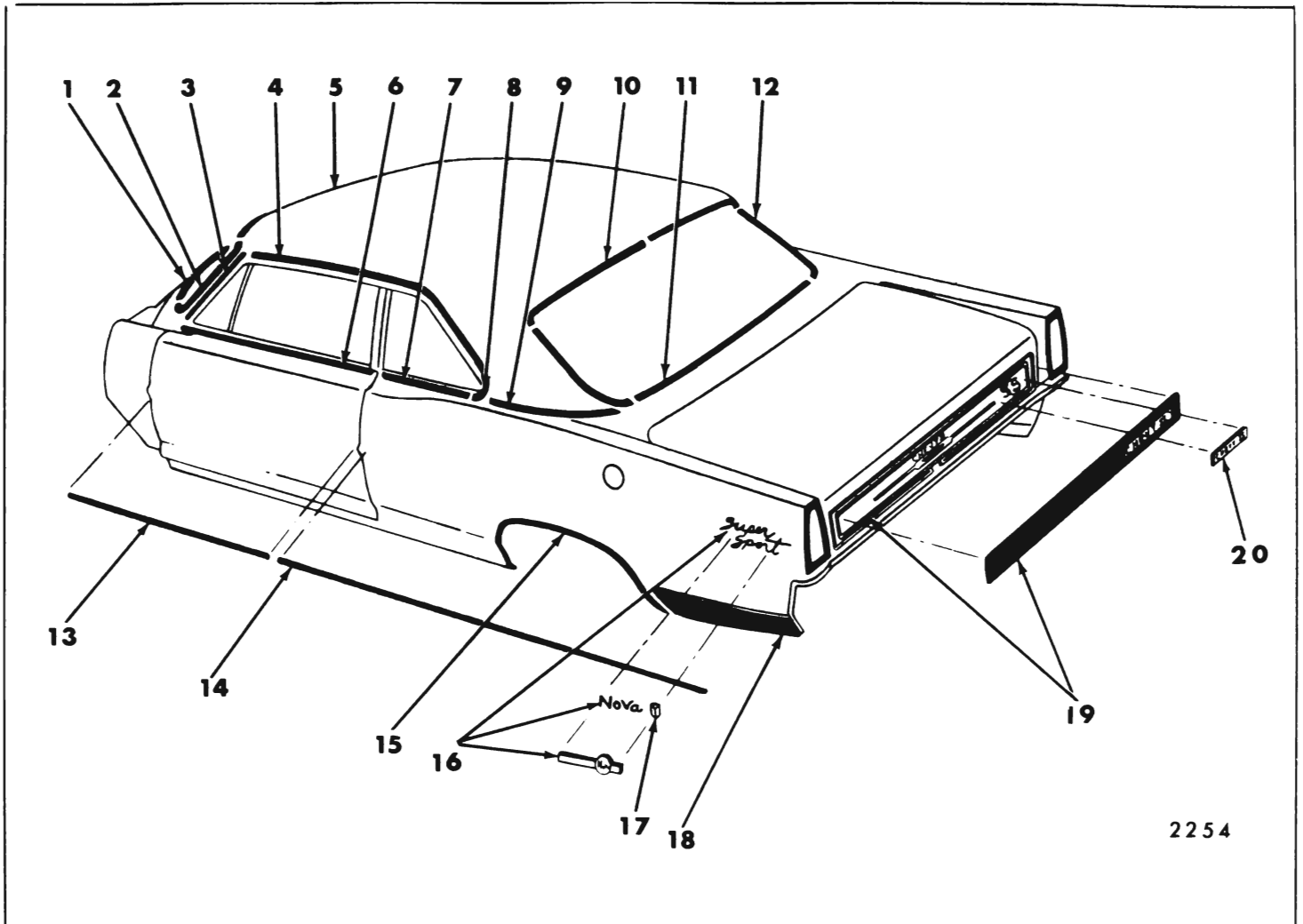

Fig. 12-5—Chevy II "X-37" Styles

1. Windshield Reveal Lower Molding
2. Windshield Reveal Side Molding
3. Windshield Pillar Drip Molding
4. Roof Drip Molding Scalp
5. Windshield Reveal Upper Molding
6. Front Door Window Belt Reveal Molding
7. Rear Quarter Window Belt Reveal Molding
8. Rear Quarter Window Rear Corner Belt Reveal Molding
9. Rear Quarter Belt Reveal Molding
10. Back Window Reveal Upper Molding
11. Back Window Reveal Lower Molding
12. Back Window Reveal Side Molding
13. Front Door Outer Panel Molding
14. Rear Quarter Outer Panel Molding
15. Rear Wheel Opening Molding
16. Rear Quarter Outer Panel Nameplate
17. Rear Quarter Outer Panel Emblem
18. Rear of Rear Wheel Opening Molding
19. Rear Compartment Lid Outer Panel Molding
20. Rear Compartment Lid Outer Panel Nameplate

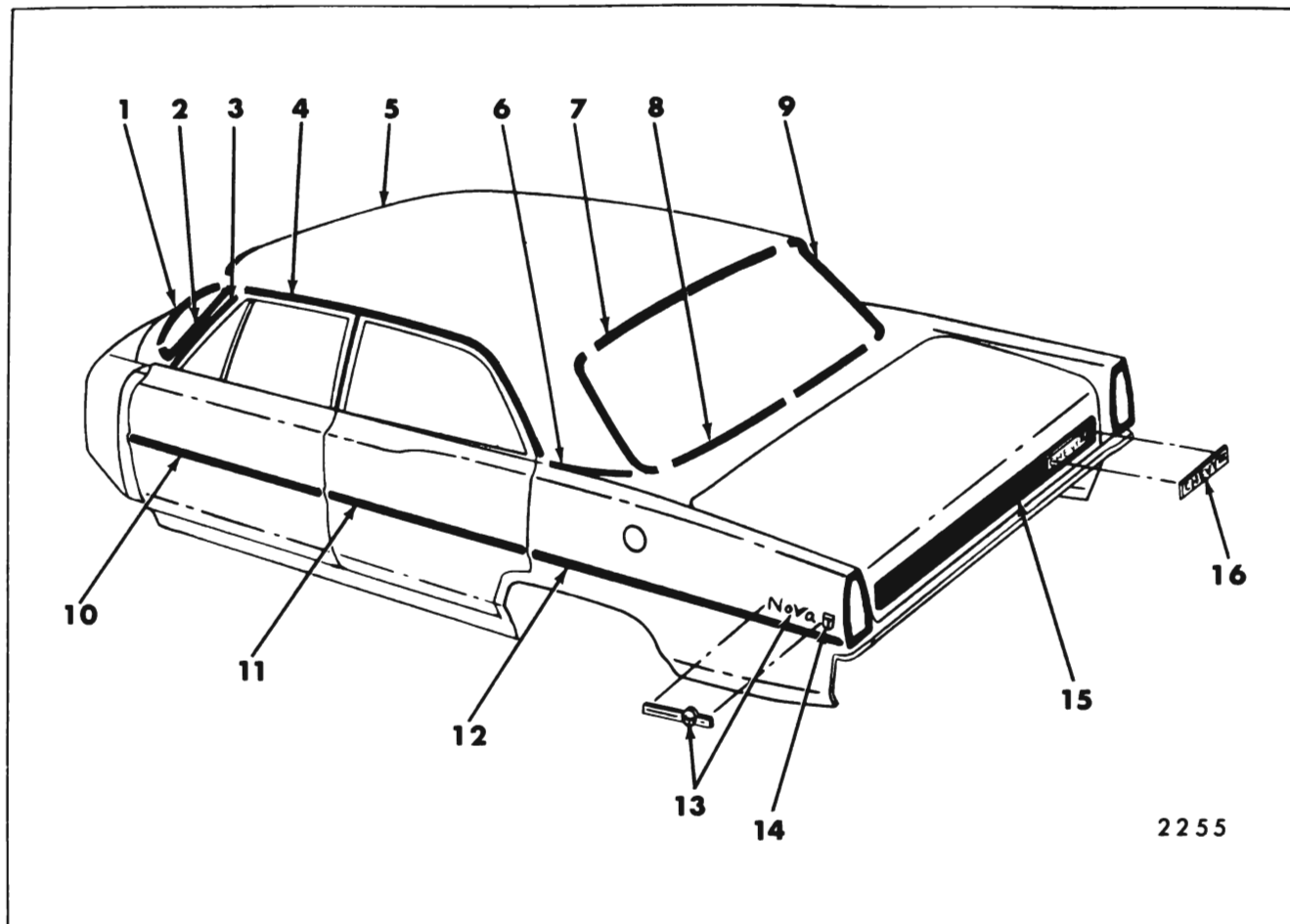

Fig. 12-6—Chevy II "X-69" Styles

1. Windshield Reveal Lower Molding
2. Windshield Reveal Side Molding
3. Windshield Pillar Drip Molding
4. Roof Drip Molding Scalp
5. Windshield Reveal Upper Molding
6. Rear Quarter Belt Reveal Molding
7. Back Window Reveal Upper Molding
8. Back Window Reveal Lower Molding
9. Back Window Reveal Side Molding
10. Front Door Outer Panel Molding
11. Rear Door Outer Panel Molding
12. Rear Quarter Outer Panel Molding
13. Rear Quarter Outer Panel Nameplate
14. Rear Quarter Outer Panel Emblem
15. Rear Compartment Lid Outer Panel Molding
16. Rear Compartment Lid Outer Panel Nameplate



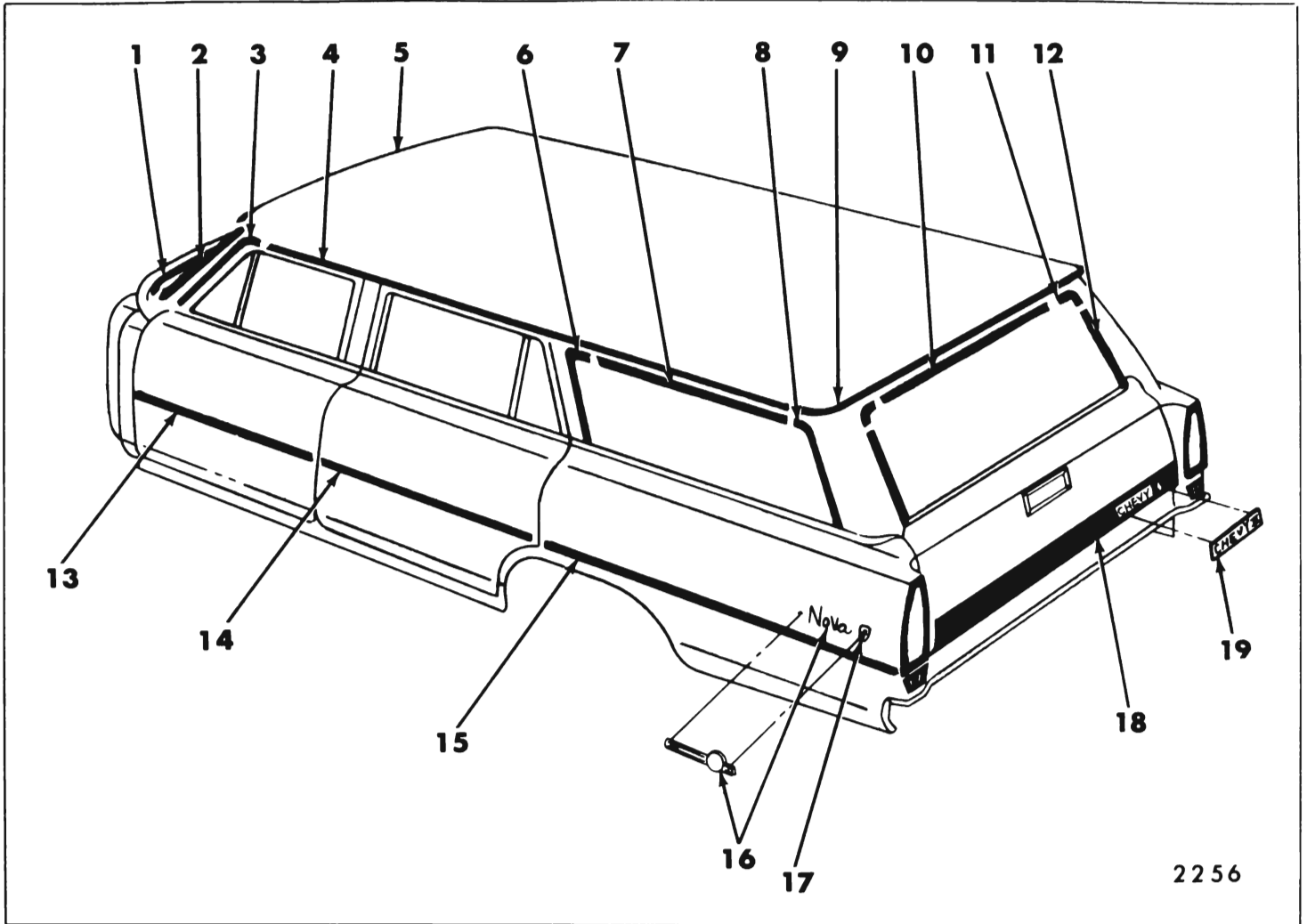

Fig. 12-7—Chevy II "X-35" Styles

1. Windshield Reveal Lower Molding
2. Windshield Reveal Side Molding
3. Windshield Pillar Drip Molding
4. Roof Drip Molding Front Scalp
5. Windshield Reveal Upper Molding
6. Rear Quarter Window Reveal Front Molding
7. Rear Quarter Window Reveal Upper Molding
8. Rear Quarter Window Reveal Rear Molding
9. Roof Drip Molding Rear Scalp
10. Back Body Opening Upper Reveal Molding
11. Back Body Opening Reveal Escutcheon
12. Back Body Opening Side Reveal Molding
13. Front Door Outer Panel Molding
14. Rear Door Outer Panel Molding
15. Rear Quarter Outer Panel Molding
16. Rear Quarter Outer Panel Nameplate
17. Rear Quarter Outer Panel Emblem
18. Tailgate Outer Panel Molding
19. Tailgate Outer Panel Nameplate

11400 - 11600 - 11800 SERIES

Molding Name	Series Or Styles	Method of Retention					Engages With Other Moldings	Remove Hardware Or Trim
		Screws	Spring (Self-Retained)	Snap-On Clips Or Retainers On Panel	Snap-On Clips On Moldings	Studs With Attaching Nuts		
Windshield Reveal Upper	All						Windshield Reveal Moldings are Removed from the Rubber Channel after the Glass and Channel are Removed from the Opening (Same As Above)	
Windshield Reveal Side	All						Overlaps the Upper and Lower Windshield Reveal Moldings (Same As Above)	
Windshield Reveal Lower	All							
Windshield Pillar Drip	All	X						
Roof Drip Molding Scalp	69		X					
Roof Drip Molding Scalp Front	35 and 37		X					
Roof Drip Molding Scalp Rear	35 and 37		X					
Back Roof Drip Molding Scalp	35		X					
Front Door Window Belt Reveal	37	X				X		
Rear Quarter Window Belt Reveal	37	X				X		
Quarter Belt Reveal	11 and 69 37 (Optional)						X	
Front Door Outer Panel	11600	X					X	
Rear Door Outer Panel	11600	X					X	

11400 - 11600 - 11800 SERIES (Cont'd.)

Molding Name	Series Or Styles	Method of Retention					Engages With Other Moldings	Remove Hardware Or Trim
		Screws	Spring (Self-Retained)	Snap-On Clips Or Retainers On Panel	Snap-On Clips On Moldings	Studs With Attaching Nuts		
Rear Quarter Outer Panel	11600			X		X		
Rear Quarter Outer Panel Emblem	All					X		
Rear Wheel Opening	11837	X						
Rear of Rear Wheel Opening	11837	X						
Back Glass Reveal Upper	All (except 35)			X				
Back Glass Reveal Side	All (except 35)			X				
Back Glass Reveal Lower	All (except 35)			X				
Back Body Opening Reveal Side	35			X				
Back Body Opening Reveal Upper	35			X				
Back Body Opening Reveal Escutcheon	35		X					
Tail Gate Outer Panel Emblem	11435						X	
Tail Gate Outer Panel Molding and Emblem Assembly	11635						X	
Rear Compartment Lid Outer Panel Emblem	11400						X	
Rear Compartment Lid Outer Panel Molding and Emblem Assembly	11600-11800						X	

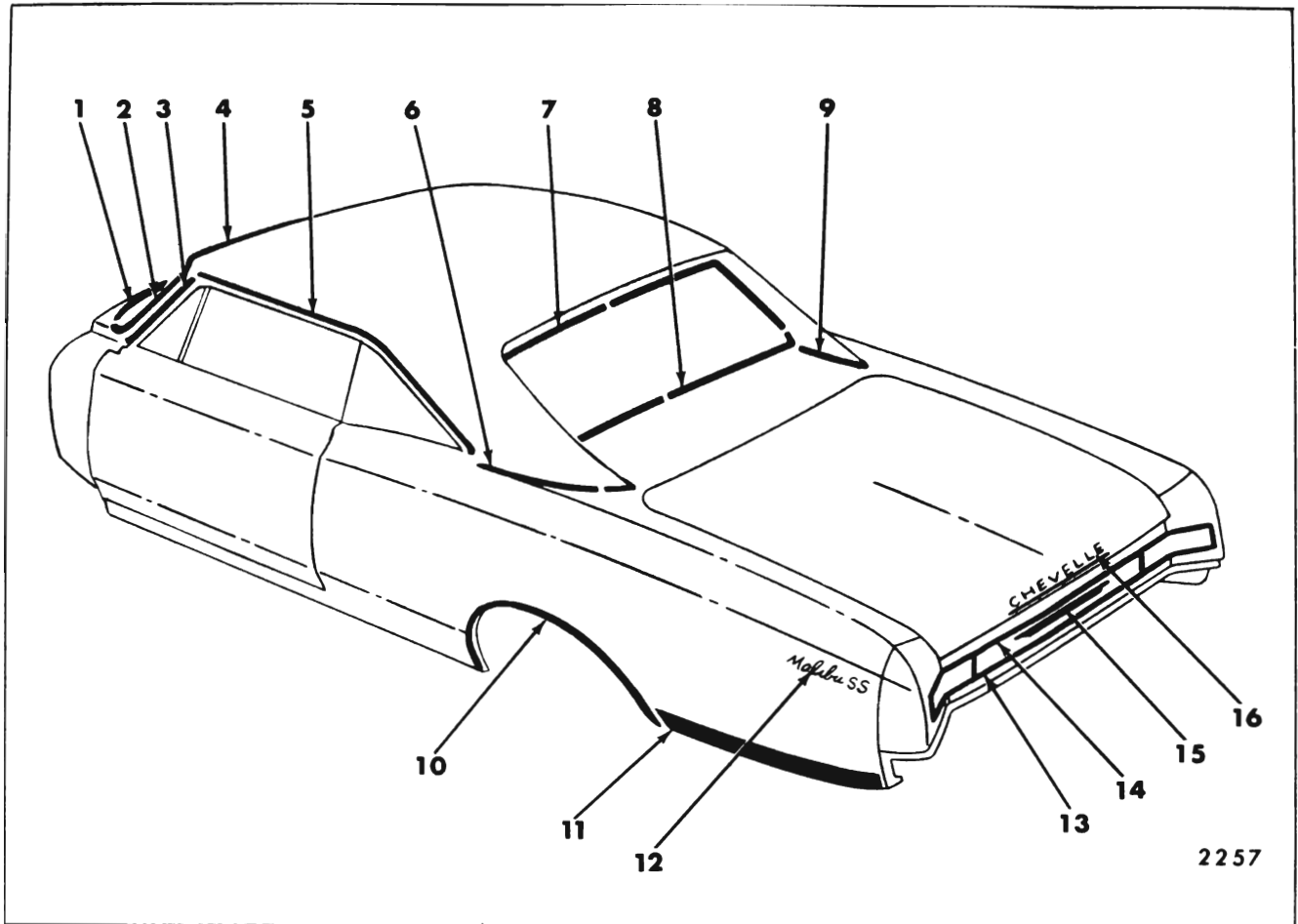

Fig. 12-8—Chevelle "A" — 13817

1. Windshield Reveal Lower Molding
2. Windshield Reveal Side Molding
3. Windshield Pillar Finishing Molding
4. Windshield Reveal Upper Molding
5. Roof Drip Molding Scalp
6. Rear Quarter Belt Reveal Molding
7. Back Window Reveal Upper Molding
8. Back Window Reveal Lower Molding
9. Rear Quarter Belt Reveal Rear Molding
10. Rear Wheel Opening Molding
11. Rear of Rear Wheel Opening Molding
12. Rear Quarter Outer Panel Nameplate
13. Rear End Panel Lower Molding
14. Rear End Panel Upper Molding
15. Rear End Panel Emblem
16. Rear Compartment Lid Outer Panel Nameplate

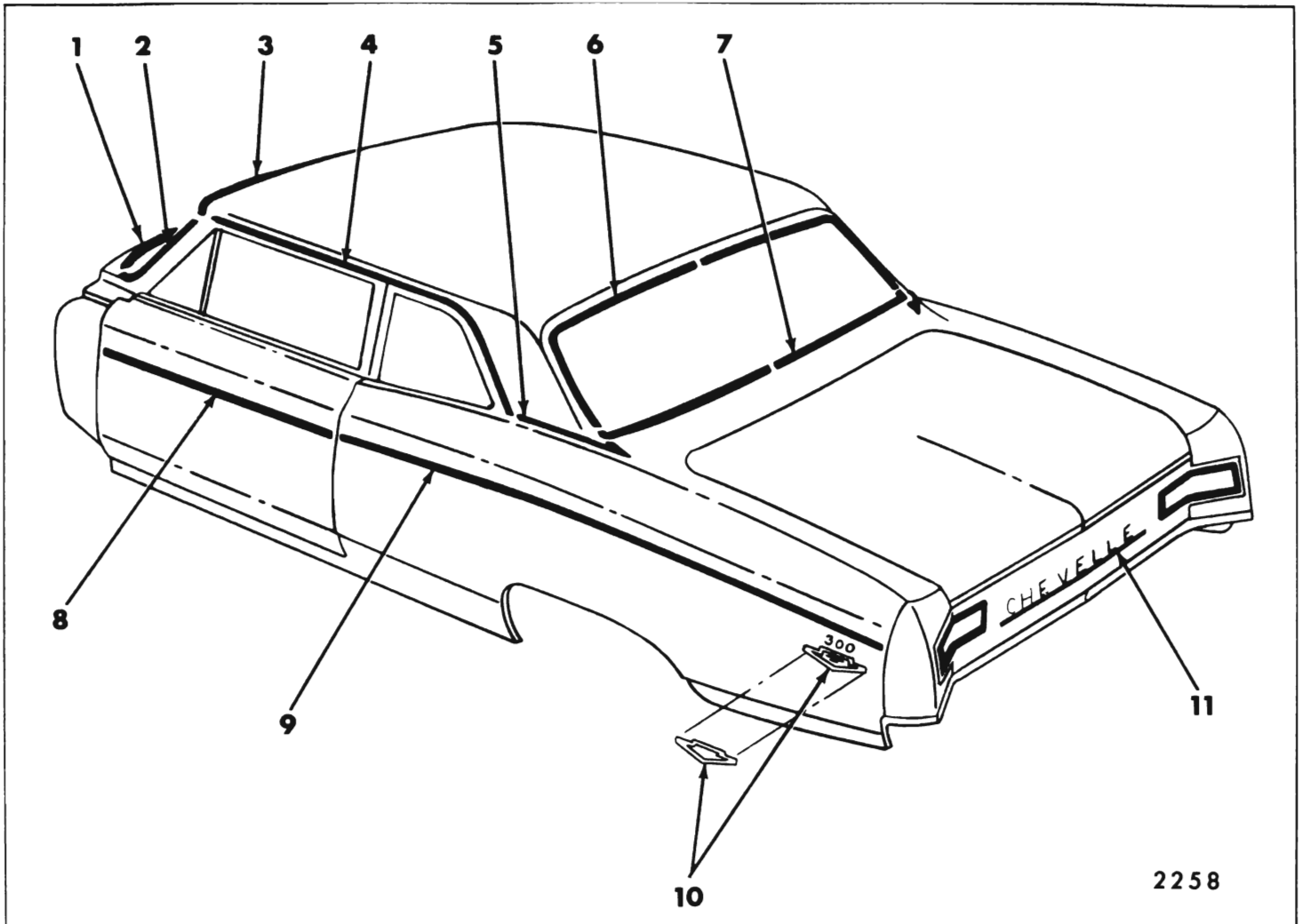

Fig. 12-9—Chevelle "A-11" Styles

1. Windshield Reveal Lower Molding
2. Windshield Reveal Side Molding
3. Windshield Reveal Upper Molding
4. Roof Drip Molding Scalp
5. Rear Quarter Belt Reveal Molding
6. Back Window Reveal Upper Molding
7. Back Window Reveal Lower Molding
8. Front Door Outer Panel Molding
9. Rear Quarter Outer Panel Molding
10. Rear Quarter Outer Panel Emblem
11. Rear End Panel Nameplate

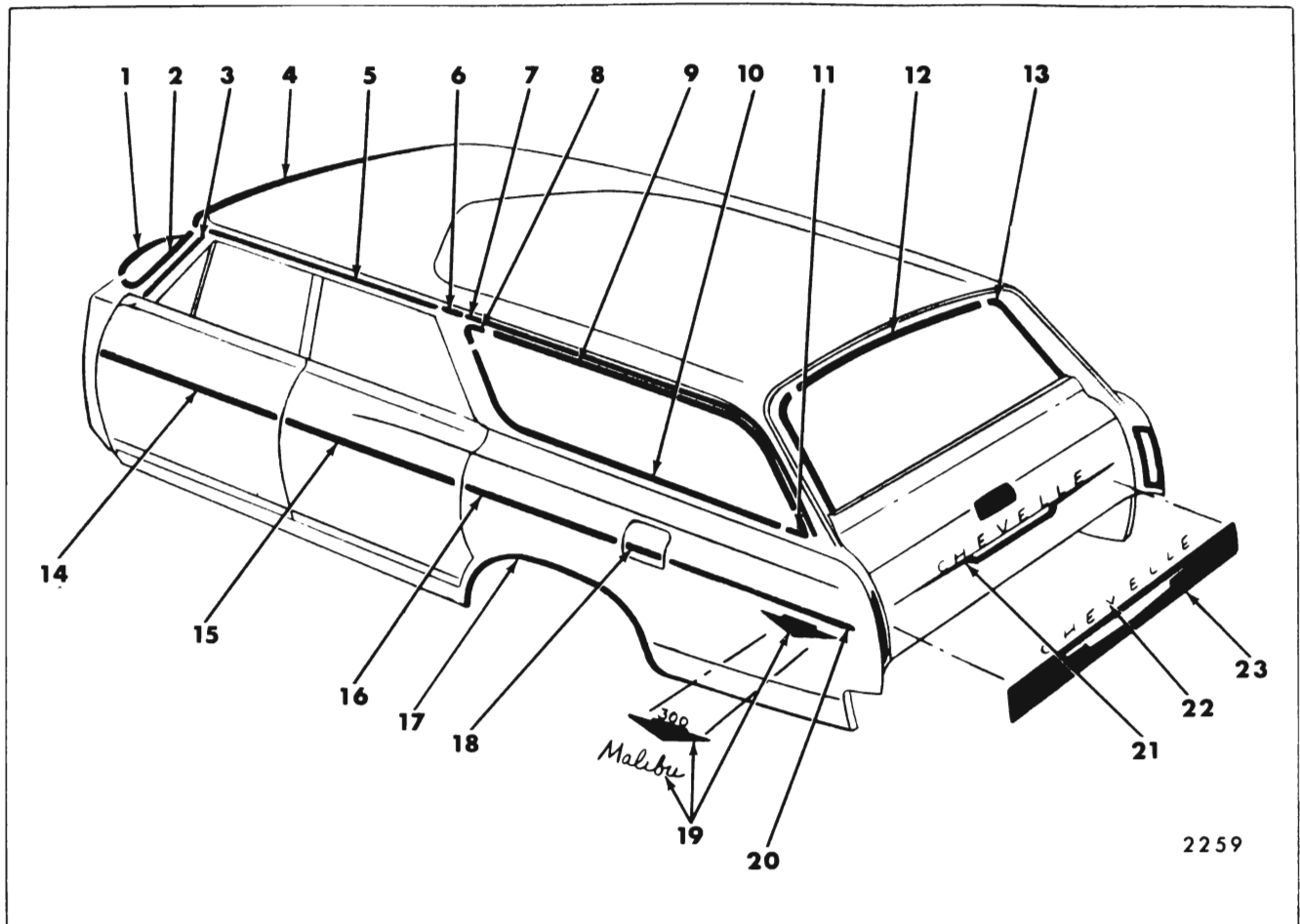

Fig. 12-10—Chevelle "A-35" Styles

1. Windshield Reveal Lower Molding
2. Windshield Reveal Side Molding
3. Windshield Pillar Finishing Molding
4. Windshield Reveal Upper Molding
5. Roof Drip Molding Front Scalp
6. Roof Drip Molding Scalp Escutcheon
7. Roof Drip Molding Rear Scalp
8. Rear Quarter Window Reveal Upper Corner Escutcheon
9. Rear Quarter Window Reveal Upper Molding
10. Rear Quarter Window Reveal Lower Molding
11. Rear Quarter Window Reveal Lower Corner Escutcheon
12. Back Body Opening Upper Reveal Molding
13. Back Body Opening Side Reveal Molding
14. Front Door Outer Panel Molding
15. Rear Door Outer Panel Molding
16. Rear Quarter Outer Panel Front Molding
17. Rear Wheel Opening Molding
18. Gas Tank Filler Door Molding
19. Rear Quarter Outer Panel Emblem
20. Rear Quarter Outer Panel Rear Molding
21. Tailgate Outer Panel Emblem
22. Tailgate Outer Panel Nameplate
23. Tailgate Outer Panel Molding

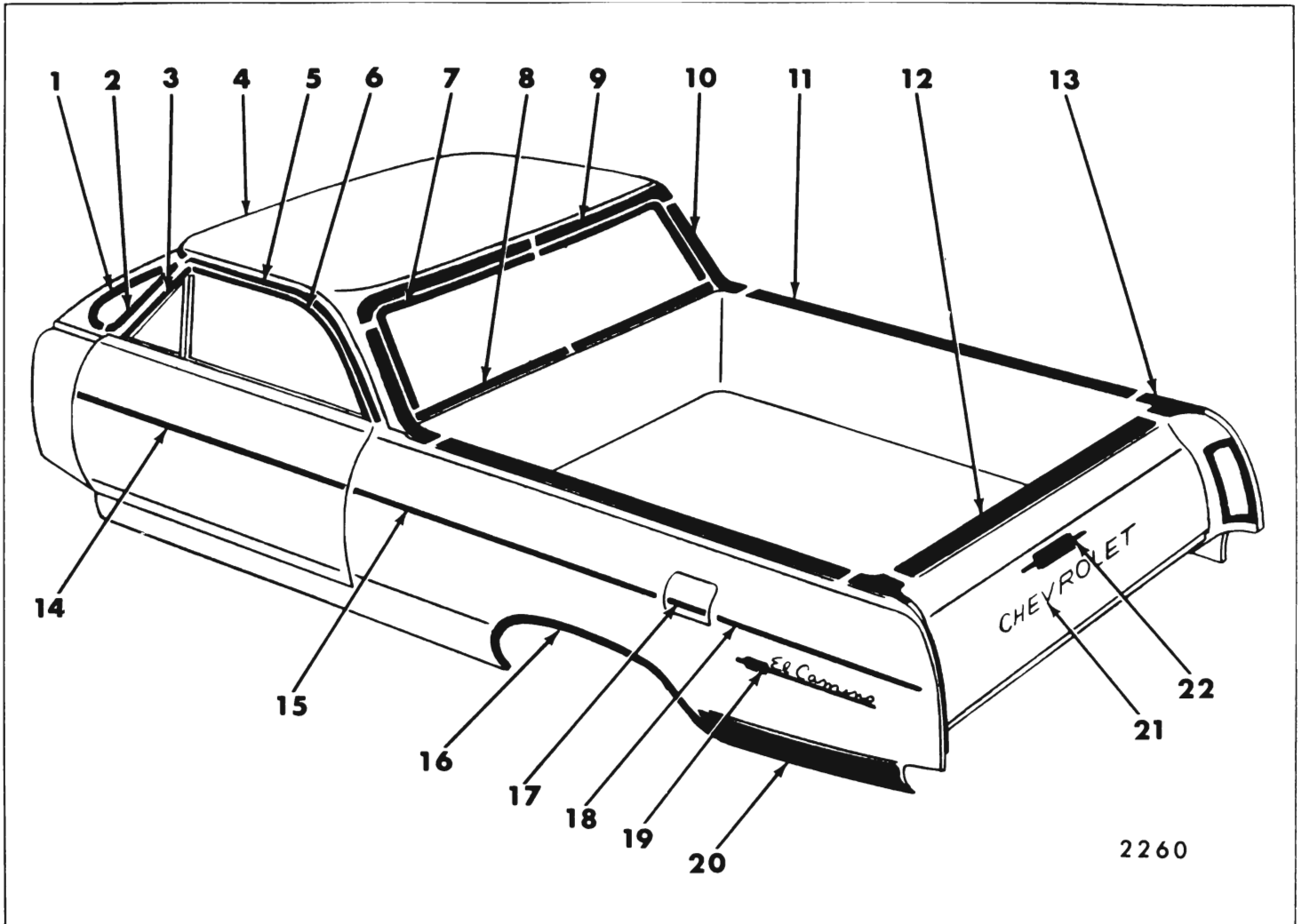

Fig. 12-11—Chevelle "A-80" Styles

1. Windshield Reveal Lower Molding
2. Windshield Reveal Side Molding
3. Front Door Window Frame Front Scalp Molding
4. Windshield Reveal Upper Molding
5. Roof Drip Molding Scalp
6. Front Door Window Frame Upper Scalp Molding
7. Back Window Reveal Upper Molding
8. Back Window Reveal Lower Molding
9. Roof Panel Upper Finishing Molding
10. Roof Panel Side Finishing Molding
11. Quarter Pinchweld Finishing Molding
12. Tailgate Belt Finishing Molding
13. Quarter Pinchweld Rear Finishing Molding
14. Front Door Outer Panel Molding
15. Rear Quarter Outer Panel Front Molding
16. Rear Wheel Opening Molding
17. Gas Tank Filler Door Molding
18. Rear Quarter Outer Panel Rear Molding
19. Rear Quarter Outer Panel Nameplate
20. Rear of Rear Wheel Opening Molding
21. Tailgate Outer Panel Nameplate
22. Tailgate Outer Panel Emblem

2260

13200 - 13400 - 13600 - 13800 SERIES

Molding Name	Series Or Styles	Method of Retention					Engages With Other Moldings	Remove Hardware Or Trim
		Screws	Spring (Self-Retained)	Snap-On Clips Or Retainers On Panel	Snap-On Clips On Moldings	Studs With Attaching Nuts		
Windshield Reveal Upper	All			X			Windshield Reveal Side	
Windshield Reveal Side	All			X			Windshield Reveal Lower	Windshield Reveal Upper
Windshield Reveal Lower	All			X			Windshield Reveal Side	Windshield Reveal Side
Windshield Pillar Finishing	67 & 80	X						Windshield Pillar Weatherstrip and Weatherstrip Retainer (67 Style)
Roof Drip Scalp Molding	11, 69, 80		X					
Roof Drip Scalp Molding Front	35 & 17		X				Roof Drip Molding Scalp Escutcheon	
Roof Drip Scalp Molding Rear	35 & 17		X				Roof Drip Molding Scalp Escutcheon	
Roof Drip Scalp Molding Escutcheon	35 & 17		X					
Roof Panel Rear Finishing	80						Right Side Overlaps Left Side Back Window Side Escutcheon	Finishing Lace. Dome Lamp. Rear of Headlining



13200 - 13400 - 13600 - 13800 SERIES (Cont'd.)

Molding Name	Series Or Styles	Method of Retention					Engages With Other Moldings	Remove Hardware Or Trim
		Screws	Spring (Self-Retained)	Snap-On Clips Or Retainers On Panel	Snap-On Clips On Moldings	Studs With Attaching Nuts		
Back Window Side Finishing	80					X	Quarter Pinchweld Belt Finishing at Front	Finishing Lace, Side Foundation
Front Door Window Frame Scalp Upper	80		X				Front Door Window Frame Scalp Front	
Front Door Window Frame Scalp Front	80		X					
Quarter Pinchweld Belt Finishing Front	80			X		X	Quarter Pinchweld Belt Finishing Rear	Quarter Inner Access Hole Cover
Quarter Pinchweld Belt Finishing Rear	80			X		X	Quarter Pinchweld Belt Finishing Front	Quarter Inner Access Hole Cover
Rear Quarter Front Reveal (Painted)	11		X				Quarter Window Upper Reveal	
Rear Quarter Upper Reveal (Painted)	11		X					
Quarter Pinchweld Finishing	67					X		Rear Quarter & Rear End Trim Sticks
Quarter Belt Reveal	11, 17, 69					X	Back Window Lower Reveal (11, 69 Only)	
Rear End Pinchweld Finishing	67			X			Quarter Pinchweld Finishing Molding	Rear Quarter & Rear End Trim Sticks

13200 - 13400 - 13600 - 13800 SERIES (Cont'd.)

Molding Name	Series Or Styles	Method of Retention					Engages With Other Moldings	Remove Hardware Or Trim
		Screws	Spring (Self-Retained)	Snap-On Clips Or Retainers On Panel	Snap-On Clips On Moldings	Studs With Attaching Nuts		
Quarter Window Reveal Upper Corner Escutcheon	35			X			Quarter Window Reveal Upper	Loosen Quarter Window Reveal Upper and Lower at Corner
Quarter Window Reveal Upper	35			X			Quarter Window Reveal Upper and Lower Corner Escutcheon	Quarter Window Reveal Upper Corner Escutcheon
Quarter Window Reveal Lower	35			X			Quarter Window Reveal Upper and Lower Corner Escutcheon	Quarter Window Reveal Lower Corner Escutcheon
Quarter Window Reveal Lower Corner Escutcheon	35			X			Quarter Window Reveal Lower	Loosen Quarter Window Reveal Upper and Lower at Corner
Front Door Outer Panel	13400	X						
Rear Door Outer Panel	13400	X						
Rear Quarter Outer Panel	13400			X				
Rear Wheel Opening	13600-13800	X						
Rear of Rear Wheel Opening	13800-13680							
Rear Quarter Outer Panel Nameplate and/or Emblem	All							
Rear Compartment Lid Nameplate	13600-13800 Exc. 35, 80							

13200 - 13400 - 13600 - 13800 SERIES (Cont'd.)

Molding Name	Series Or Styles	Method of Retention					Engages With Other Moldings	Remove Hardware Or Trim
		Screws	Spring (Self-Retained)	Snap-On Clips Or Retainers On Panel	Snap-On Clips On Moldings	Studs With Attaching Nuts		
Rear End Panel Nameplate	13200-13400 Exc. 35, 80					X		
Rear End Panel Upper	13600-13800					X		
Rear End Panel Emblem	13600-13800					X		
Rear End Panel Lower	13600-13800					X		
Back Window Reveal Upper	All except 35, 67			X			Back Window Reveal Side	
Back Window Reveal Side	All except 35, 67			X			Back Window Reveal Lower	Back Window Reveal Upper
Back Window Reveal Lower	All except 35, 67			X			Back Window Reveal Side	Back Window Reveal Side
Back Body Opening Upper Reveal	35	X						
Back Body Opening Side Reveal	35	X						
Tailgate Belt Finishing	80					X		
Tailgate Outer Panel Nameplate	35, 80					X		
Tailgate Outer Panel	13635					X		Tailgate Window and Regulator

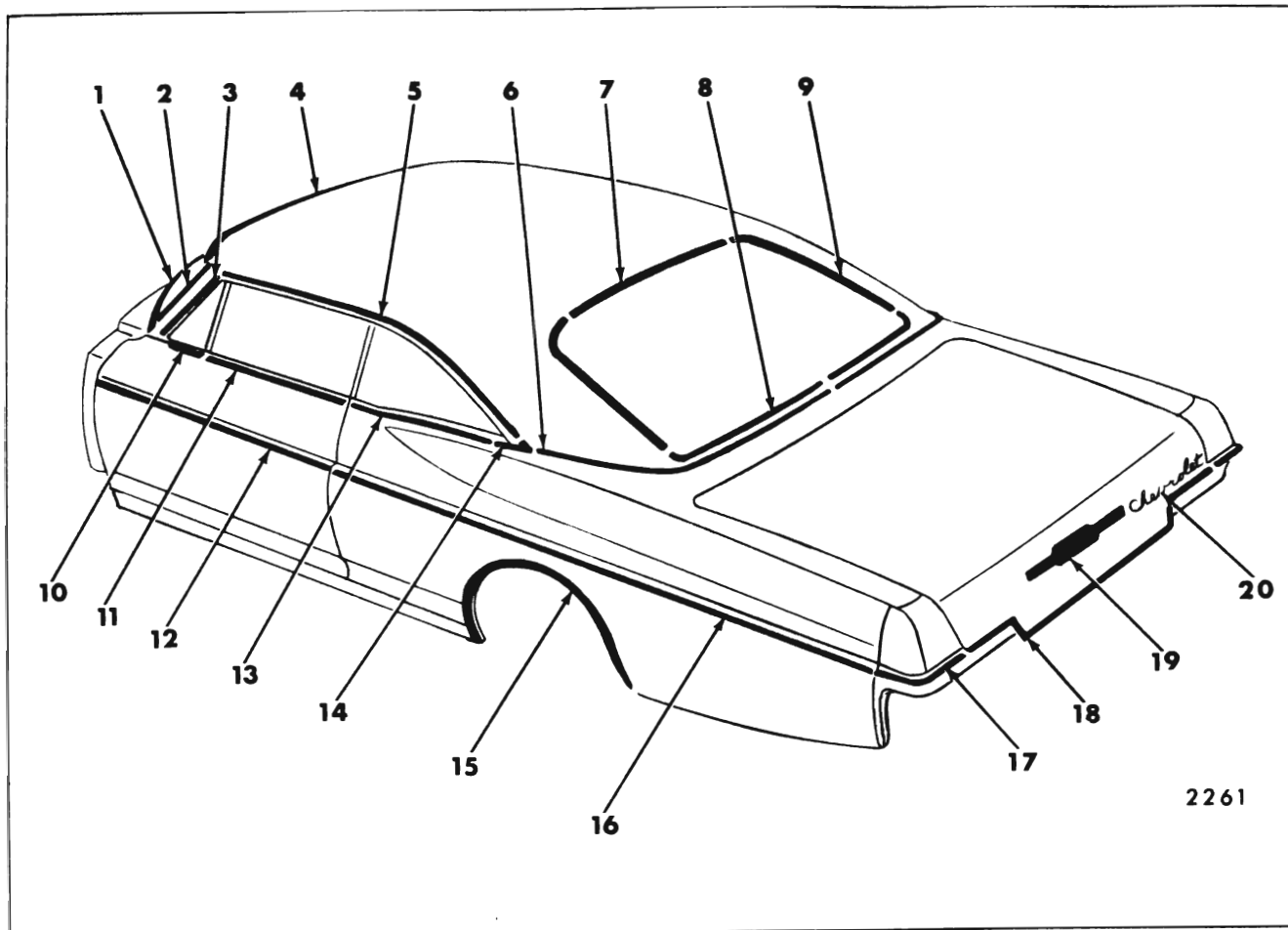

Fig. 12-12—Chevrolet "B-37" Styles

1. Windshield Reveal Lower Molding
2. Windshield Reveal Side Molding
3. Windshield Pillar Drip Molding
4. Windshield Reveal Upper Molding
5. Roof Drip Molding Scalp
6. Rear Quarter Belt Reveal Molding
7. Back Window Reveal Upper Molding
8. Back Window Reveal Lower Molding
9. Back Window Reveal Side Molding
10. Front Door Window Belt Reveal (At Vent) Molding
11. Front Door Window Belt Reveal Molding
12. Front Door Outer Panel Molding
13. Rear Quarter Window Belt Reveal Molding
14. Rear Quarter Window Belt Reveal (Rear Corner) Escutcheon
15. Rear Wheel Opening Molding
16. Rear Quarter Outer Panel Molding
17. Rear of Rear Quarter Outer Panel Molding
18. Rear Compartment Lid Outer Panel Molding
19. Rear Compartment Lid Outer Panel Emblem
20. Rear Compartment Lid Outer Panel Nameplate

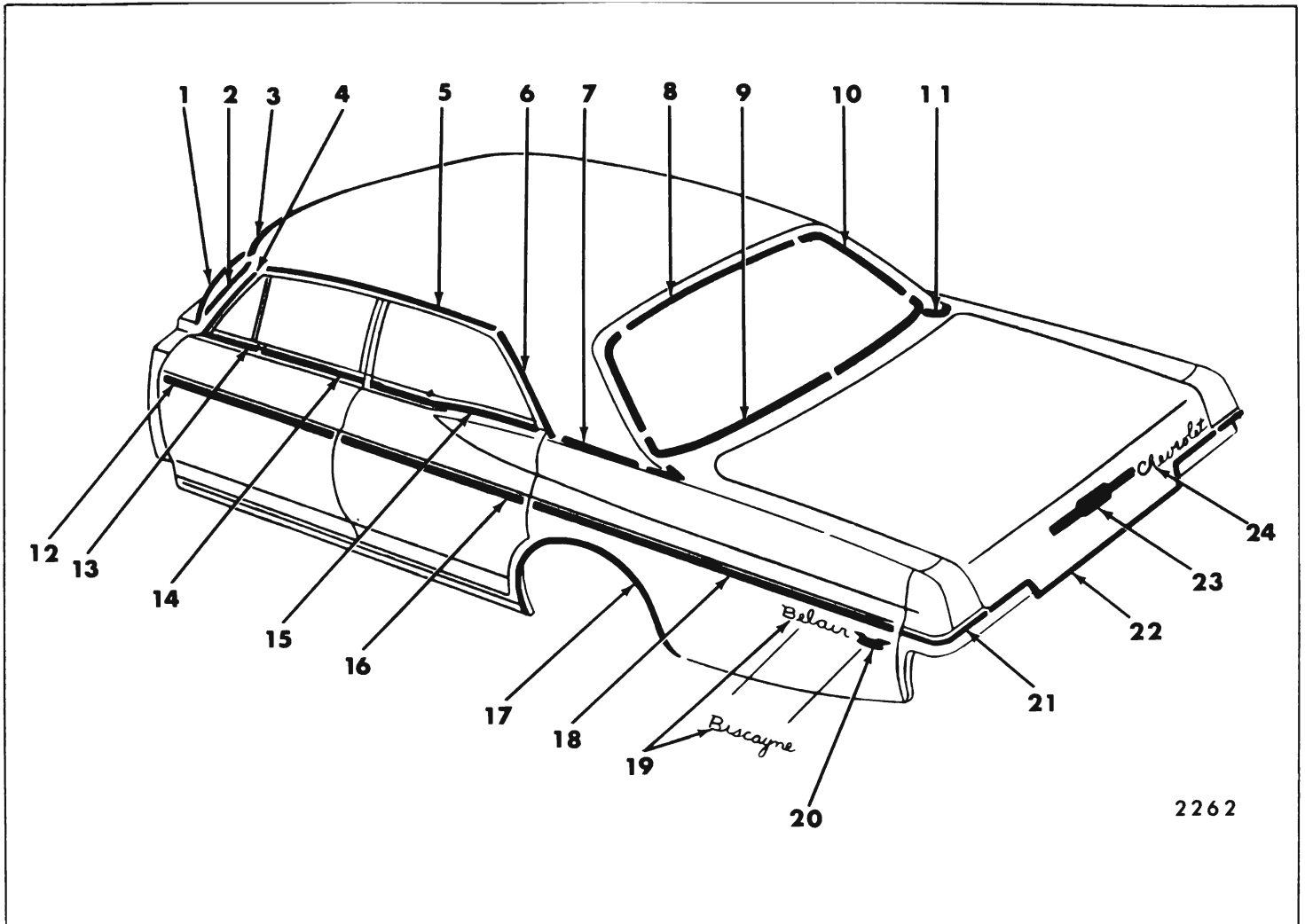

Fig. 12-13—Chevrolet "B-69" Styles

1. Windshield Reveal Lower Molding
2. Windshield Reveal Side Molding
3. Windshield Reveal Upper Molding
4. Windshield Pillar Drip Molding Scalp
5. Roof Drip Molding Front Scalp
6. Roof Drip Molding Rear Scalp
7. Rear Quarter Belt Reveal Front Molding
8. Back Window Reveal Upper Molding
9. Back Window Reveal Lower Molding
10. Back Window Reveal Side Molding
11. Rear Quarter Belt Reveal Rear Molding
12. Front Door Outer Panel Molding
13. Front Door Window Belt Reveal (At Vent) Molding
14. Front Door Window Belt Reveal Molding
15. Rear Door Window Belt Reveal Molding
16. Rear Door Outer Panel Molding
17. Rear Wheel Opening Molding
18. Rear Quarter Outer Panel Molding
19. Rear Quarter Outer Panel Nameplate
20. Rear Quarter Outer Panel Emblem
21. Rear of Rear Quarter Outer Panel Molding
22. Rear Compartment Lid Outer Panel Molding
23. Rear Compartment Lid Outer Panel Emblem
24. Rear Compartment Lid Outer Panel Nameplate

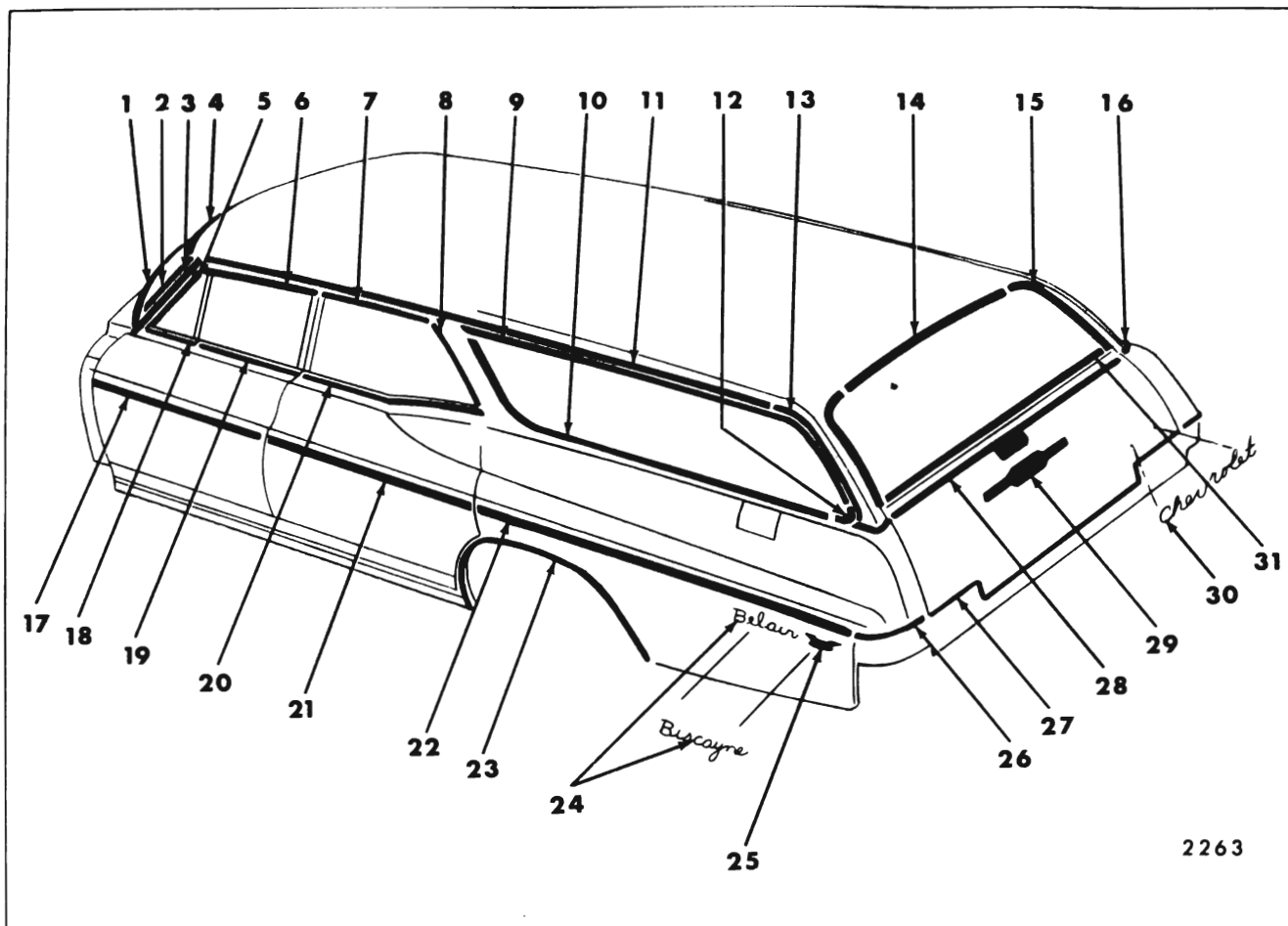

Fig. 12-14—Chevrolet "B-35-45" Styles

- |  |   |
|--|---|
| 1. Windshield Reveal Lower Molding                     | 17. Front Door Outer Panel Molding                  |
| 2. Windshield Reveal Side Molding                      | 18. Front Door Window Belt Reveal (At Vent) Molding |
| 3. Windshield Pillar Drip Molding                      | 19. Front Door Window Belt Reveal Molding           |
| 4. Windshield Reveal Upper Molding                     | 20. Rear Door Window Belt Reveal Molding            |
| 5. Front Door Window Frame Front Scalp Molding         | 21. Rear Door Outer Panel Molding                   |
| 6. Front Door Window Frame Upper Scalp Molding         | 22. Rear Quarter Outer Panel Molding                |
| 7. Rear Door Window Frame Upper Scalp Molding          | 23. Rear Wheel Opening Molding                      |
| 8. Rear Door Window Frame Rear Scalp Molding           | 24. Rear Quarter Outer Panel Nameplate              |
| 9. Rear Quarter Window Reveal Upper Molding            | 25. Rear Quarter Outer Panel Emblem                 |
| 10. Rear Quarter Window Reveal Lower Molding           | 26. Rear of Rear Quarter Outer Panel Molding        |
| 11. Roof Drip Molding Front Scalp                      | 27. Tailgate Outer Panel Lower Molding              |
| 12. Rear Quarter Window Reveal Lower Corner Escutcheon | 28. Tailgate Outer Panel Belt Reveal Molding        |
| 13. Roof Drip Molding Rear Scalp                       | 29. Tailgate Outer Panel Emblem                     |
| 14. Back Body Opening Upper Reveal Molding             | 30. Tailgate Outer Panel Nameplate                  |
| 15. Back Body Opening Side Reveal Molding              | 31. Tailgate Window Lower Reveal Molding            |
| 16. Back Body Pillar Belt Finishing Molding            |   |

15400 - 15600 - 16400 - 16600 SERIES

Molding Name	Series Or Styles	Method of Retention					Engages With Other Moldings	Remove Hardware Or Trim
		Screws	Spring (Self-Retained)	Snap-On Clips Or Retainers On Panel	Snap-On Clips On Moldings	Studs With Attaching Nuts		
Windshield Reveal Upper	All			X			Windshield Reveal Side	
Windshield Reveal Side	All			X			Windshield Reveal Lower	
Windshield Reveal Lower	All			X				Cowl Air Intake Grille
Windshield Pillar Drip	All (except 67)	X						Weatherstrip and Weatherstrip Retainer at Windshield Pillar
Windshield Pillar Finishing	67	X						Windshield Pillar Weatherstrip and Weatherstrip Retainer
Roof Drip Scalp	11, 37, 69		X				Windshield Pillar Drip	Windshield Side Reveal Molding
Roof Drip Molding Scalp Front	35, 45, 39		X				Windshield Pillar Drip	
Roof Drip Molding Scalp Rear	35, 45, 39		X				Roof Drip Molding Front Scalp	
Front Door Window Frame Scalp Front	35, 45, 69		X				Front Door Window Frame Scalp Upper	
Front Door Window Frame Scalp Upper	35, 45, 69		X					
Front Door Window Belt Reveal (at Vent)	All (except 11)	X						Front Door Vent Assy. (35, 45, 69 Styles) Front Door Trim Pad (37, 39, 67 Style)

15400 - 15600 - 16400 - 16400 SERIES (Cont'd.)

Molding Name	Series Or Styles	Method of Retention					Engages With Other Moldings	Remove Hardware Or Trim
		Screws	Spring (Self-Retained)	Snap-On Clips Or Retainers On Panel	Snap-On Clips On Moldings	Studs With Attaching Nuts		
Front Door Window Belt Reveal	16400-16600	X		X			Front Door Window Reveal (at Vent)	Rubber Bumper on Front Door Window Lower Stop
Rear Door Window Frame Scalp Upper	35, 45, 69		X				Rear Door Window Frame Rear Scalp (35, 45 Styles Only)	
Rear Door Window Frame Scalp Rear	35, 45		X					
Rear Door Window Belt Reveal	16400-16600	X		X				Rubber Bumper on Rear Door Window Lower Stop
Quarter Window Reveal Front (Painted)	11		X				Quarter Window Upper Reveal	
Quarter Window Reveal Upper (Painted)	11		X					
Quarter Window Belt Reveal	16400-16600	X			X			Quarter Window Lower Stop
Quarter Window Belt Reveal Lower Escutcheon	37	X						
Quarter Window Reveal Upper	35, 45				X		Quarter Window Reveal Lower	
Quarter Window Reveal Lower	35, 45				X			Quarter Window Reveal Lower Escutcheon
Quarter Window Reveal Lower Escutcheon	35, 45				X		Quarter Window Reveal Upper and Lower	



15400 - 15600 - 16400 - 16600 SERIES (Cont'd.)

Molding Name	Series Or Styles	Method of Retention					Engages With Other Moldings	Remove Hardware Or Trim
		Screws	Spring (Self-Retained)	Snap-On Clips Or Retainers On Panel	Snap-On Clips On Moldings	Studs With Attaching Nuts		
Quarter Pinchweld Finishing	67	X			X			
Front Door Outer Panel	15600-16400	X		X				
Rear Door Outer Panel	15600-16400	X		X				
Rear Quarter Outer Panel	15600-16400			X		X		
Rear Wheel Opening	16400-16600	X						
Rear Quarter Outer Panel Nameplate	15400-15600 35-45 Left Side			X				
Rear Quarter Outer Panel Nameplate	15400-15600 16600 35-45 Right Side					X		
Rear of Rear Quarter Outer Panel	35, 45	X				X	Rear of Rear Quarter Extension Loosen Rear Bumper	
Rear of Rear Quarter Outer Panel	15600-16400 16600	X						
Rear of Rear Quarter Outer Panel Lower (Vertical)	16600	X						
Back Glass Reveal Upper	All (except 35, 45, 67)			X			Back Glass Reveal Side	
Back Glass Reveal Side	All (except 35, 45, 67)			X			Back Glass Reveal Lower	
Back Glass Reveal Lower	All (except 35, 45, 67)			X			Back Glass Reveal Side	

15400 - 15600 - 16400 - 16600 SERIES (Cont'd.)

Molding Name	Series Or Styles	Method of Retention					Engages With Other Moldings	Remove Hardware Or Trim
		Screws	Spring (Self-Retained)	Snap-On Clips Or Retainers On Panel	Snap-On Clips On Moldings	Studs With Attaching Nuts		
Back Body Opening Reveal Upper	35, 45	X					Back Body Opening Reveal Side	Remove Upper Glass Run Channel
Back Body Opening Reveal Side	35, 45	X					Back Body Opening Reveal Upper	
Tailgate Window Reveal	35, 45	X			X			Tailgate Window and Regulator
Tailgate Outer Panel Belt Reveal (Optional)	35, 45	X			X			
Tailgate Outer Panel Emblem	All Series 35-45 Styles					X		Tailgate Inner Trim Panel
Tailgate Outer Panel Nameplate	All Series 35-45 Styles					X		Tailgate Inner Trim Panel
Tailgate Outer Panel Lower	15600-16400 16600 35, 45 Styles	X				X		
Back Body Pillar Belt Finishing (Optional)	35, 45	X				X		
Rear Compartment Lid Outer Panel Emblem	All							
Rear Compartment Lid Outer Panel	All	X						

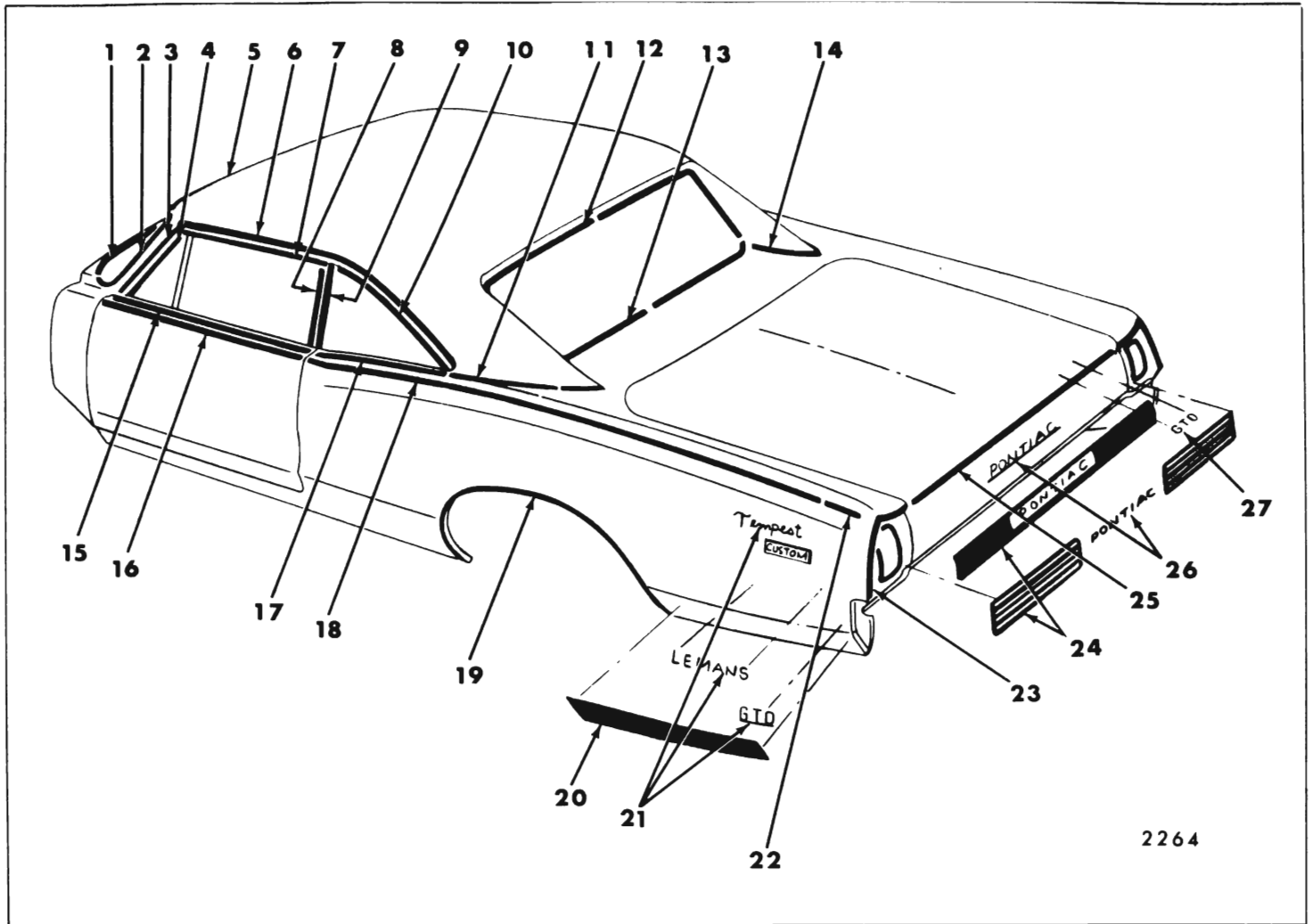

Fig. 12-15—Tempest "A-07" Styles

- |  |  |
|--|--|
| 1. Windshield Reveal Lower Molding             | 15. Front Door Window Belt Reveal Molding    |
| 2. Windshield Reveal Side Molding              | 16. Front Door Outer Panel Molding           |
| 3. Windshield Pillar Finishing Molding         | 17. Rear Quarter Window Belt Reveal Molding  |
| 4. Front Door Window Frame Front Scalp Molding | 18. Rear Quarter Outer Panel Front Molding   |
| 5. Windshield Reveal Upper Molding             | 19. Rear Wheel Opening Molding               |
| 6. Roof Drip Molding Scalp                     | 20. Rear of Rear Wheel Opening Molding       |
| 7. Front Door Window Frame Upper Scalp Molding | 21. Rear Quarter Outer Panel Nameplate       |
| 8. Front Door Window Frame Rear Scalp Molding  | 22. Rear Quarter Outer Panel Rear Molding    |
| 9. Quarter Window Front Scalp Molding          | 23. Rear of Rear Quarter Outer Panel Molding |
| 10. Quarter Window Upper Scalp Molding         | 24. Rear End Panel Molding                   |
| 11. Rear Quarter Belt Reveal Molding           | 25. Rear Compartment Lid Outer Panel Molding |
| 12. Back Window Reveal Upper Molding           | 26. Rear End Panel Nameplate                 |
| 13. Back Window Reveal Lower Molding           | 27. Rear Compartment Lid Outer Panel Emblem  |
| 14. Rear Quarter Belt Reveal Rear Molding      |  |

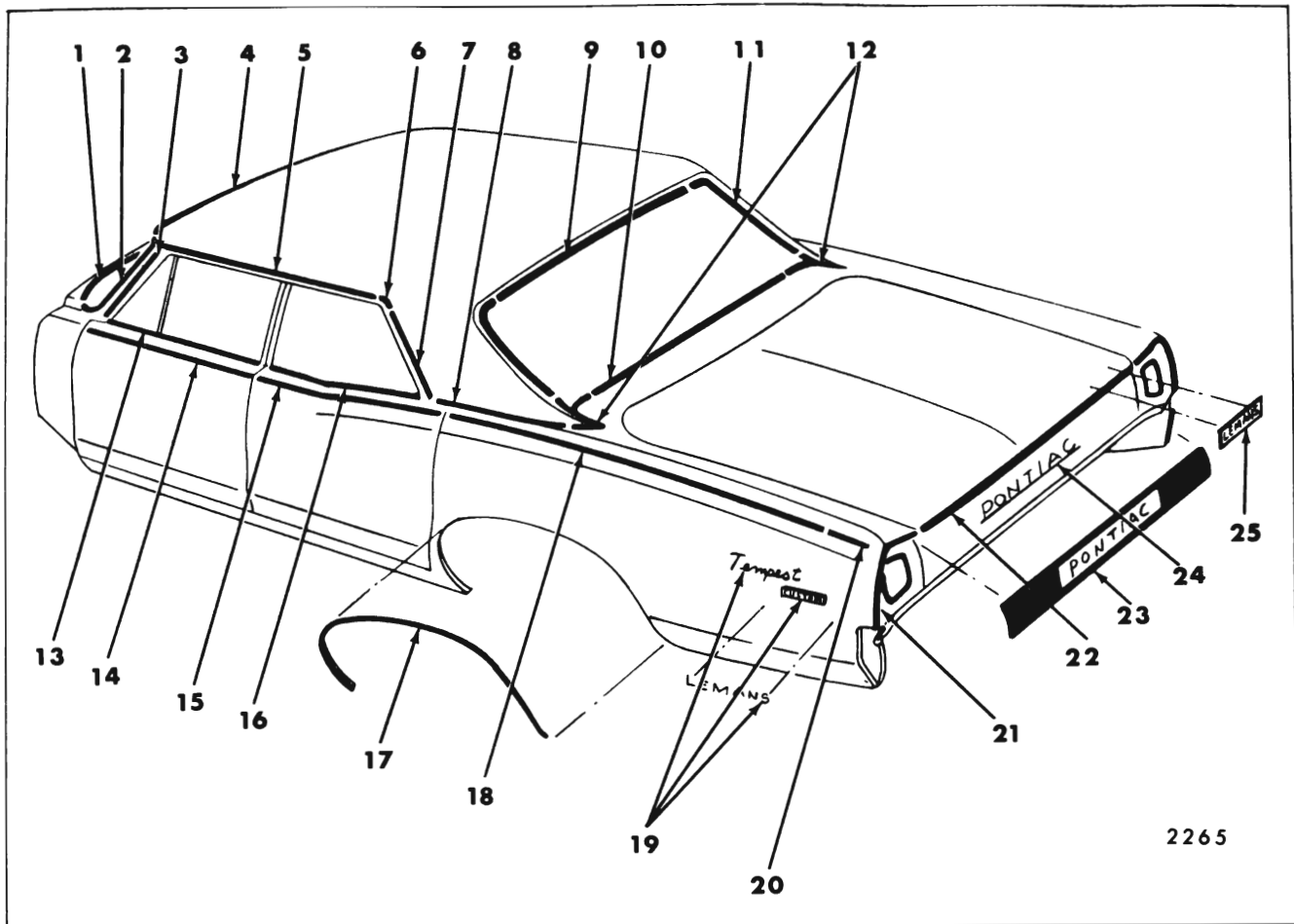

Fig. 12-16—Tempest "A-39" Styles

- |  |  |
|--|--|
| 1. Windshield Reveal Lower Molding             | 14. Front Door Outer Panel Molding             |
| 2. Windshield Reveal Side Molding              | 15. Rear Door Outer Panel Molding              |
| 3. Windshield Pillar Finishing Molding         | 16. Rear Door Window Belt Reveal Molding       |
| 4. Windshield Reveal Upper Molding             | 17. Rear Wheel Opening Molding                 |
| 5. Roof Drip Molding Front Scalp               | 18. Rear Quarter Outer Panel Front Molding     |
| 6. Roof Drip Molding Scalp Escutcheon          | 19. Rear Quarter Outer Panel Nameplate         |
| 7. Roof Drip Molding Rear Scalp                | 20. Rear Quarter Outer Panel Rear Molding      |
| 8. Rear Quarter Belt Reveal Molding            | 21. Rear of Rear Quarter Outer Panel Molding   |
| 9. Back Window Reveal Upper Molding            | 22. Rear Compartment Lid Outer Panel Molding   |
| 10. Back Window Reveal Lower Molding           | 23. Rear End Panel Molding                     |
| 11. Back Window Reveal Side Molding            | 24. Rear End Panel Nameplate                   |
| 12. Rear Quarter Belt Reveal Corner Escutcheon | 25. Rear Compartment Lid Outer Panel Nameplate |
| 13. Front Door Window Belt Reveal Molding      |  |

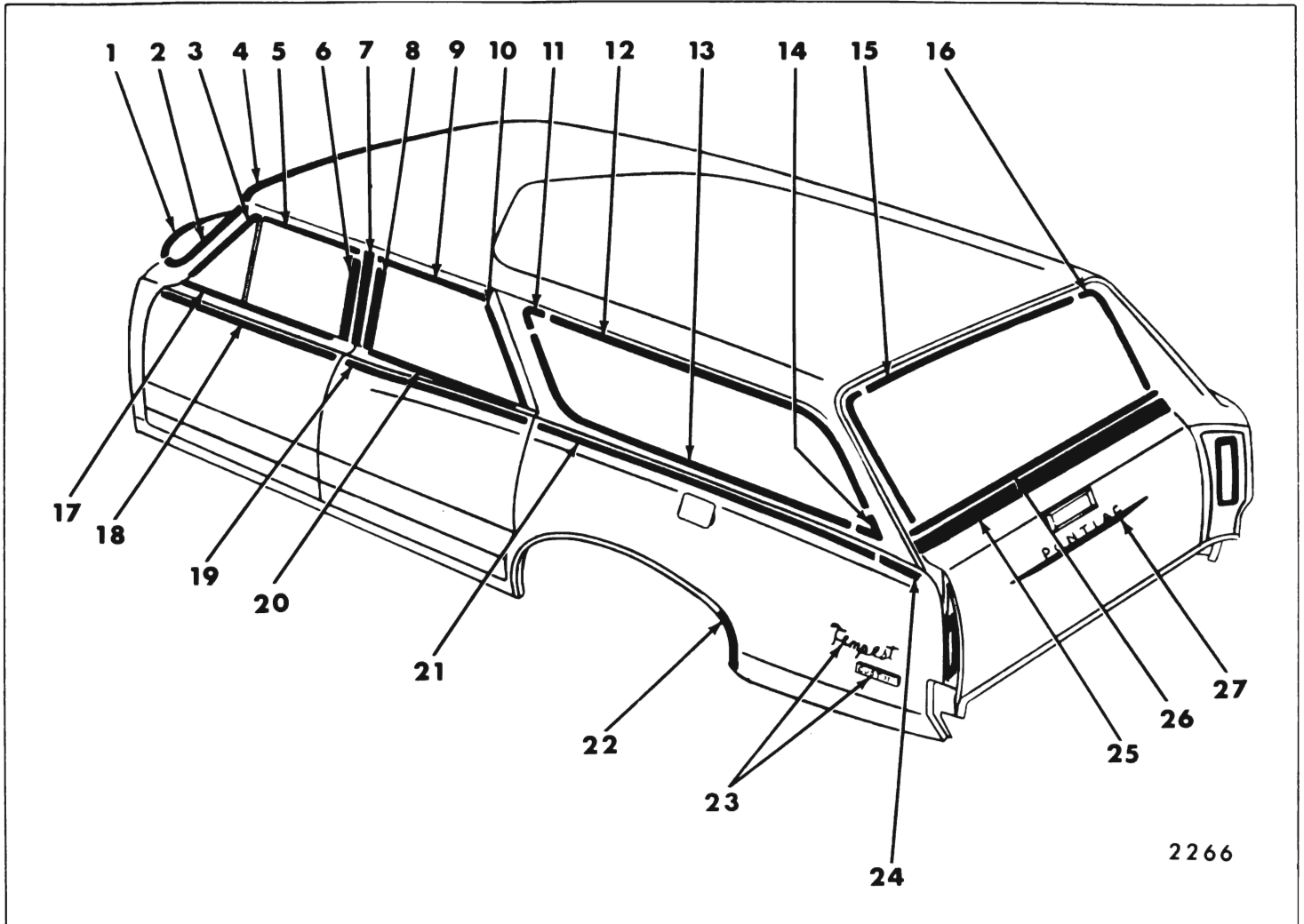

Fig. 12-17—Tempest "A-35" Styles

- |  |  |
|--|--|
| 1. Windshield Reveal Lower Molding                     | 15. Back Body Opening Upper Reveal Molding |
| 2. Windshield Reveal Side Molding                      | 16. Back Body Opening Side Reveal Molding  |
| 3. Front Door Window Frame Front Scalp Molding         | 17. Front Door Window Belt Reveal Molding  |
| 4. Windshield Reveal Upper Molding                     | 18. Front Door Outer Panel Molding         |
| 5. Front Door Window Frame Upper Scalp Molding         | 19. Rear Door Outer Panel Molding          |
| 6. Front Door Window Frame Rear Scalp Molding          | 20. Rear Door Window Belt Reveal Molding   |
| 7. Center Pillar Scalp Molding                         | 21. Rear Quarter Outer Panel Front Molding |
| 8. Rear Door Window Frame Front Scalp Molding          | 22. Rear Wheel Opening Stone Shield        |
| 9. Rear Door Window Frame Upper Scalp Molding          | 23. Rear Quarter Outer Panel Nameplate     |
| 10. Rear Door Window Frame Rear Scalp Molding          | 24. Rear Quarter Outer Panel Rear Molding  |
| 11. Rear Quarter Window Reveal Upper Corner Escutcheon | 25. Tailgate Outer Panel Belt Molding      |
| 12. Rear Quarter Window Reveal Upper Molding           | 26. Tailgate Window Lower Reveal Molding   |
| 13. Rear Quarter Window Reveal Lower Molding           | 27. Tailgate Outer Panel Nameplate         |
| 14. Rear Quarter Window Reveal Lower Corner Escutcheon |  |

23300 - 23500 - 23700 - 24200 SERIES

Molding Name	Series Or Styles	Method of Retention					Engages With Other Moldings	Remove Hardware Or Trim
		Screws	Spring (Self-Retained)	Snap-On Clips Or Retainers On Panel	Snap-On Clips On Moldings	Studs With Attaching Nuts		
Windshield Reveal Upper	All			X			Windshield Reveal Side	
Windshield Reveal Side	All			X			Windshield Reveal Lower	Windshield Reveal Upper
Windshield Reveal Lower	All			X			Windshield Reveal Side	Windshield Reveal Side
Windshield Pillar Finishing	07, 17, 67, 69	X						Windshield Pillar Weatherstrip and Weatherstripper Retainer (37 67 Styles Only)
Roof Drip Molding Front Scalp	07, 17, 69		X				Roof Drip Molding Scalp Escutcheon	
Roof Drip Molding Rear Scalp	07, 17, 69		X				Roof Drip Molding Scalp Escutcheon	
Roof Drip Molding Scalp Escutcheon	07, 17, 69		X					
Roof Panel Emblem	69					X		Headlining Rear Quarter Trim Panel
Front Door Window Frame Front Scalp	07, 35, 69		X					
Front Door Window Frame Upper Scalp	07, 35, 69		X				Front Door Window Frame Front Scalp	
Front Door Window Frame Rear Scalp	07, 35, 69		X				Front Door Window Frame Upper Scalp	

23300 - 23500 - 23700 - 24200 SERIES (Cont'd.)

Molding Name	Series Or Styles	Method of Retention					Engages With Other Moldings	Remove Hardware Or Trim
		Screws	Spring (Self-Retained)	Snap-On Clips Or Retainers On Panel	Snap-On Clips On Moldings	Studs With Attaching Nuts		
Front Door Window Belt Reveal	07, 37, 69, 67	X					Front Door Window Glass Lower Stops	
Center Pillar Scalp	35, 69	X						
Rear Door Window Frame Front Scalp	35, 69		X			Rear Door Window Frame Upper Scalp		
Rear Door Window Frame Upper Scalp	35, 69		X			Rear Door Window Frame Rear Scalp		
Rear Door Window Frame Rear Scalp	35, 69		X					
Rear Door Window Belt Reveal	69	X					Rear Door Window Lower Stops	
Quarter Window Front Scalp	07			X		Quarter Window Upper Reveal		
Quarter Window Upper Scalp	07			X				
Quarter Window Lower Belt Reveal	07, 17, 67	X					Quarter Window Glass Lower Stops	
Quarter Belt Reveal	07, 17, 69					Rear End Belt		
Quarter Belt Reveal Corner Escutcheon	39							
Quarter Pinchweld Finishing	67	X				Quarter Window Lower Reveal	Rear Quarter and Rear End Trim Sticks	

23300 - 23500 - 23700 - 24200 SERIES (Cont'd.)

Molding Name	Series Or Styles	Method of Retention					Engages With Other Moldings	Remove Hardware Or Trim
		Screws	Spring (Self-Retained)	Snap-On Clips Or Retainers On Panel	Snap-On Clips On Moldings	Studs With Attaching Nuts		
Rear End Pinchweld Finishing	67	X		X			Quarter Pinchweld Finishing	Rear Quarter and Rear End Trim Sticks
Quarter Window Reveal Upper Corner Escutcheon	35			X			Quarter Window Reveal Upper	Loosen Quarter Window Reveal Upper and Lower at Corner
Quarter Window Reveal Upper	35			X			Quarter Window Reveal Upper and Corner Escutcheon	Quarter Window Reveal Upper Corner Escutcheon
Quarter Window Reveal Lower	35			X			Quarter Window Reveal Upper and Lower Corner Escutcheon	Quarter Window Reveal Lower Corner Escutcheon
Quarter Window Reveal Lower Corner Escutcheon	35			X			Quarter Window Reveal Lower	Loosen Quarter Window Reveal Upper and Lower at Corner
Front Door Outer Panel	23500	X					Quarter Window Reveal Lower	
Rear Door Outer Panel	23500	X					Quarter Window Reveal Lower	
Rear Quarter Outer Panel Front	23500							
Rear Quarter Outer Panel Rear	23500							



23300 - 23500 - 23700 - 24200 SERIES (Cont'd.)

Molding Name	Series Or Styles	Method of Retention					Engages With Other Moldings	Remove Hardware Or Trim
		Screws	Spring (Self-Retained)	Snap-On Clips Or Retainers On Panel	Snap-On Clips On Moldings	Studs With Attaching Nuts		
Rear Wheel Opening Stone Guard	35	X						
Rear Wheel Opening	23700, 24200	X						
Rear of Rear Wheel Opening	24200	X						
Rear Quarter Outer Panel Nameplate and/or Emblem	All					X		Quarter Trim Left Side Spare Tire Cover Right Side (35 Style Only)
Rear of Rear Quarter Outer Panel	All					X		
Rear Compartment Lid Outer Panel	All	X						
Rear Compartment Lid Outer Panel Nameplate and/or Emblem	23500, 24200						X	
Rear End Panel	23700, 24200						X	
Rear End Panel Nameplate	23300, 23500 24200						X	

23300 - 23500 - 23700 - 24200 SERIES (Cont'd.)

Molding Name	Series Or Styles	Method of Retention					Engages With Other Moldings	Remove Hardware Or Trim
		Screws	Spring (Self-Retained)	Snap-On Clips Or Retainers On Panel	Snap-On Clips On Moldings	Studs With Attaching Nuts		
Back Window Reveal Upper	All except 35, 67			X			Back Window Reveal Side	
Back Window Reveal Side	All except 35, 67			X			Back Window Reveal Lower	Back Window Reveal Upper
Back Window Reveal Lower	All except 35, 67			X			Back Window Reveal Side	Back Window Reveal Side
Back Body Opening Upper Reveal	35	X					Back Body Opening Side Reveal	Tailgate Window Glass Run Channel
Back Body Opening Side Reveal	35	X					Back Body Opening Upper Reveal	
Tailgate Window Lower Reveal	35	X			X			Tailgate Window
Tailgate Outer Panel Belt	35						Tailgate Window Lower Reveal	Tailgate Window and Regulator
Tailgate Outer Panel Nameplate	35							Tailgate Window and Regulator

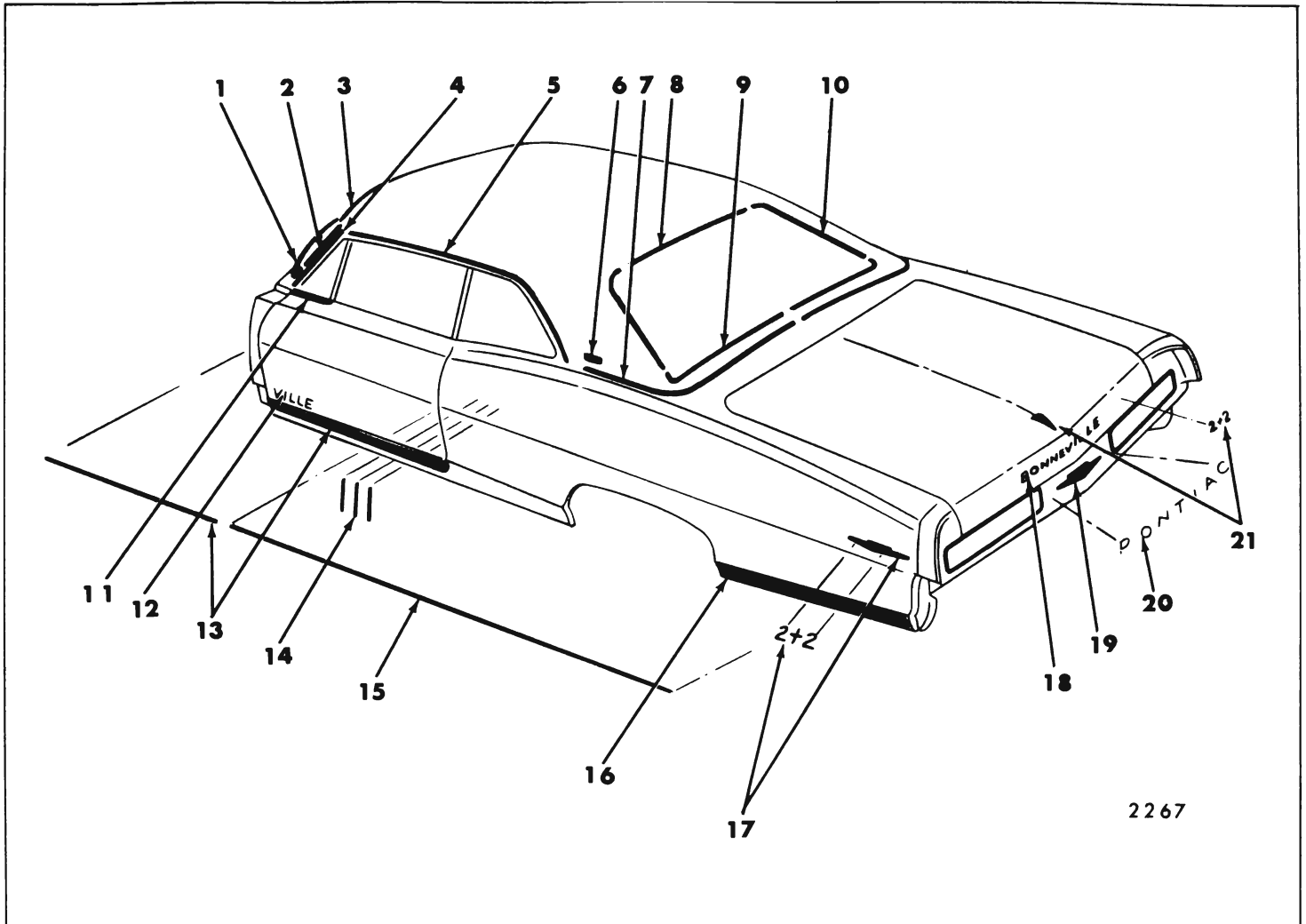

2267

Fig. 12-18—Pontiac "B-37" Styles

1. Windshield Reveal Lower Molding
2. Windshield Reveal Side Molding
3. Windshield Reveal Upper Molding
4. Windshield Pillar Drip Molding Scalp
5. Roof Drip Molding Scalp
6. Roof Panel Emblem
7. Rear Quarter Belt Reveal Molding
8. Back Window Reveal Upper Molding
9. Back Window Reveal Lower Molding
10. Back Window Reveal Side Molding
11. Front Door Window Belt Reveal (At Vent) Molding
12. Front Door Outer Panel Nameplate
13. Front Door Outer Panel Molding
14. Rear Quarter Outer Panel Louver Moldings
15. Rear Quarter Outer Panel Molding
16. Rear of Rear Wheel Opening Molding
17. Rear Quarter Outer Panel Emblem
18. Rear Compartment Lid Outer Panel Nameplate
19. Rear End Panel Emblem
20. Rear End Panel Nameplate
21. Rear Compartment Lid Outer Panel Emblem

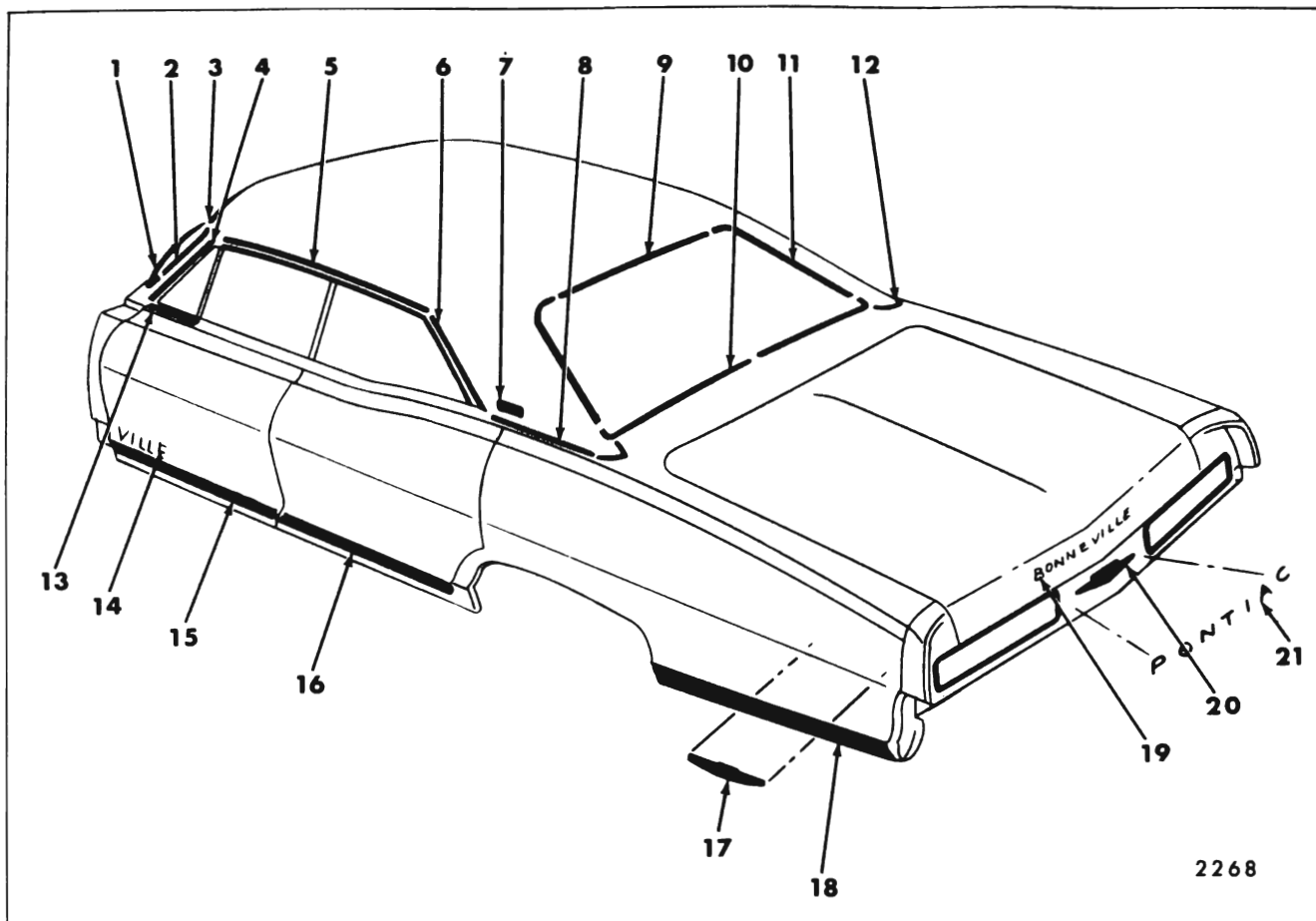

Fig. 12-19—Pontiac "B-39" Styles

1. Windshield Reveal Lower Molding
2. Windshield Reveal Side Molding
3. Windshield Reveal Upper Molding
4. Windshield Pillar Drip Molding
5. Roof Drip Molding Front Scalp
6. Roof Drip Molding Rear Scalp
7. Roof Panel Emblem
8. Rear Quarter Belt Reveal Molding
9. Back Window Reveal Upper Molding
10. Back Window Reveal Lower Molding
11. Back Window Reveal Side Molding
12. Rear Quarter Belt Reveal Rear Molding
13. Front Door Window Belt Reveal (At Vent) Molding
14. Front Door Outer Panel Nameplate
15. Front Door Outer Panel Molding
16. Rear Door Outer Panel Molding
17. Rear Quarter Outer Panel Emblem
18. Rear of Rear Wheel Opening Molding
19. Rear Compartment Lid Outer Panel Nameplate
20. Rear End Panel Emblem
21. Rear End Panel Nameplate

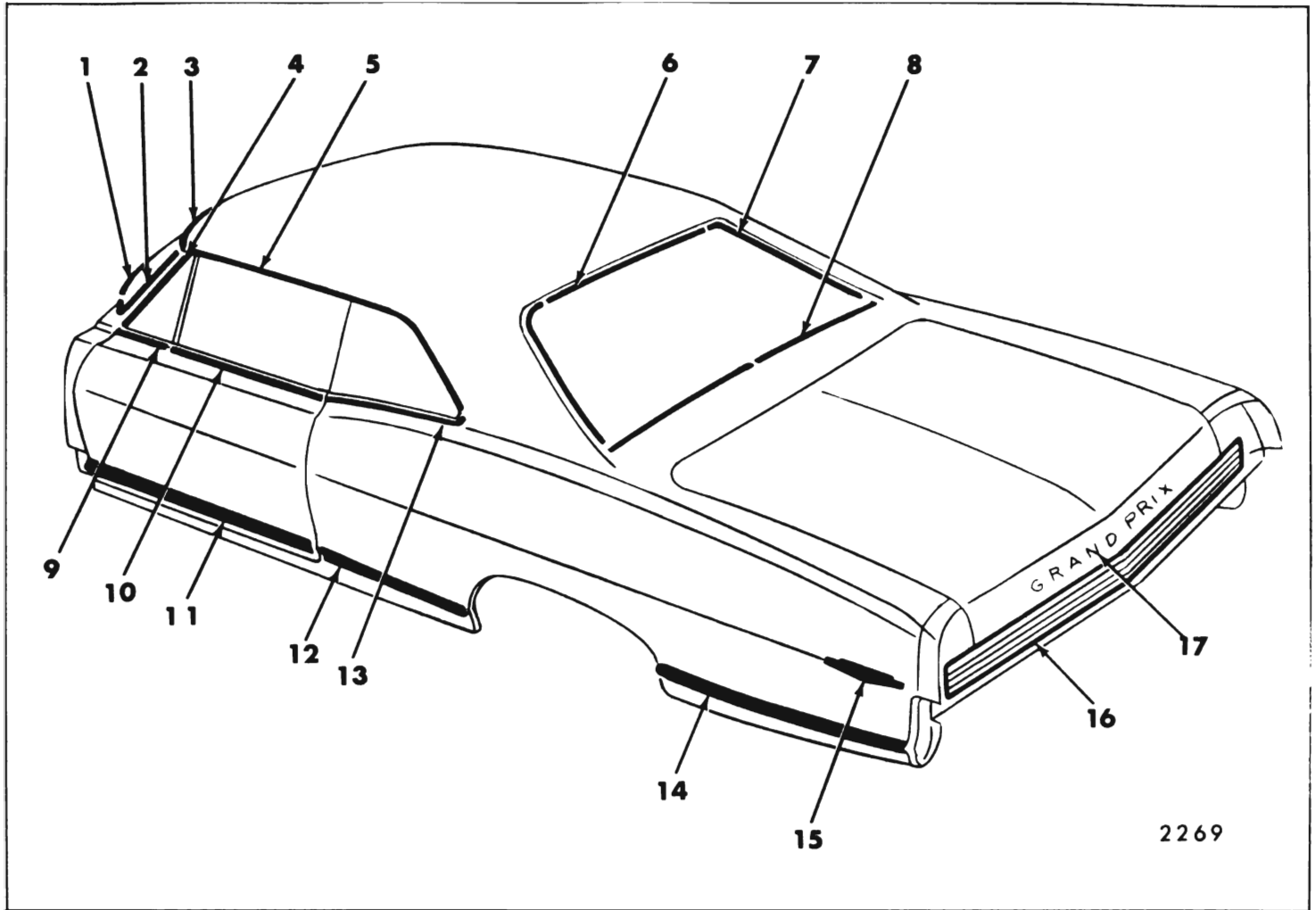

Fig. 12-20—Pontiac "B-57" Style

1. Windshield Reveal Lower Molding
2. Windshield Reveal Side Molding
3. Windshield Reveal Upper Molding
4. Windshield Pillar Drip Molding
5. Roof Drip Molding Scalp
6. Back Window Reveal Upper Molding
7. Back Window Reveal Side Molding
8. Back Window Reveal Lower Molding
9. Front Door Window Belt Reveal (At Vent) Molding
10. Front Door Window Belt Reveal Molding
11. Front Door Outer Panel Molding
12. Front of Rear Wheel Opening Molding
13. Rear Quarter Window Belt Reveal Molding
14. Rear of Rear Wheel Opening Molding
15. Rear Quarter Outer Panel Emblem
16. Rear End Panel Molding
17. Rear Compartment Lid Outer Panel Nameplate

2269

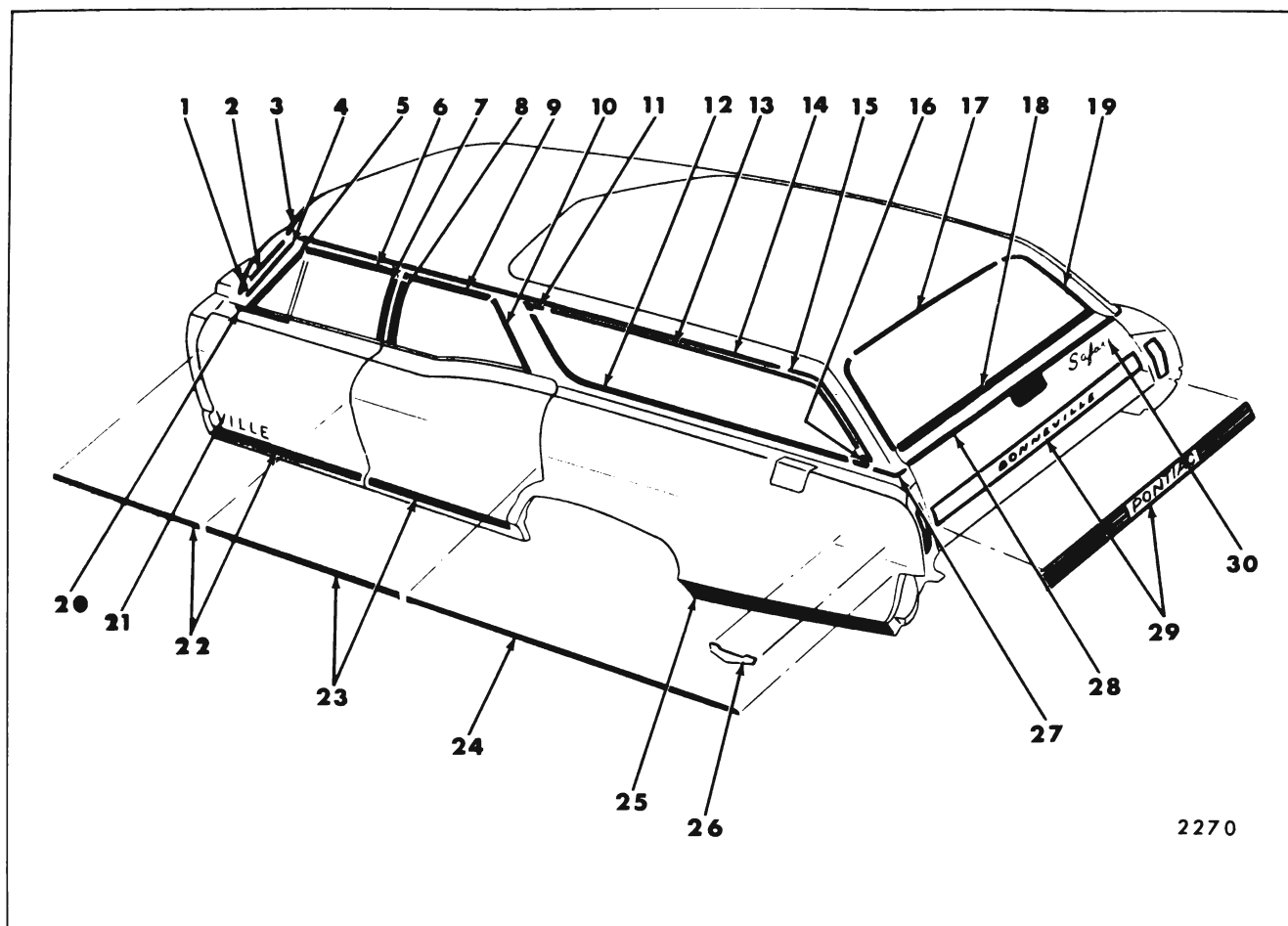

Fig. 12-21--Pontiac "B-35 and 45" Styles

- |  |  |
|--|--|
| 1. Windshield Reveal Lower Molding                     | 16. Rear Quarter Window Reveal Lower Corner Escutcheon |
| 2. Windshield Reveal Side Molding                      | 17. Back Body Opening Upper Reveal Molding             |
| 3. Windshield Reveal Upper Molding                     | 18. Tailgate Window Lower Reveal Molding               |
| 4. Windshield Pillar Drip Molding                      | 19. Back Body Opening Side Reveal Molding              |
| 5. Front Door Window Frame Front Scalp Molding         | 20. Front Door Window Belt Reveal (At Vent) Molding    |
| 6. Front Door Window Frame Upper Scalp Molding         | 21. Front Door Outer Panel Nameplate                   |
| 7. Front Door Window Frame Rear Scalp Molding          | 22. Front Door Outer Panel Molding                     |
| 8. Rear Door Window Frame Front Scalp Molding          | 23. Rear Door Outer Panel Molding                      |
| 9. Rear Door Window Frame Upper Scalp Molding          | 24. Rear Quarter Outer Panel Molding                   |
| 10. Rear Door Window Frame Rear Scalp Molding          | 25. Rear of Rear Wheel Opening Molding                 |
| 11. Rear Quarter Window Reveal Upper Corner Escutcheon | 26. Rear Quarter Outer Panel Emblem                    |
| 12. Rear Quarter Window Reveal Lower Molding           | 27. Back Body Pillar Belt Finishing Molding            |
| 13. Rear Quarter Window Reveal Upper Molding           | 28. Tailgate Outer Panel Belt Molding                  |
| 14. Roof Drip Molding Front Scalp                      | 29. Tailgate Outer Panel Molding                       |
| 15. Roof Drip Molding Rear Scalp                       | 30. Tailgate Outer Panel Nameplate                     |

25200 - 25400 - 25600 - 26200 - 26600 SERIES

Molding Name	Series Or Styles	Method of Retention					Engages With Other Moldings	Remove Hardware Or Trim
		Screws	Spring (Self-Retained)	Snap-On Clips Or Retainers On Panel	Snap-On Clips On Moldings	Studs With Attaching Nuts		
Windshield Reveal Upper	All			X			Windshield Reveal Side	
Windshield Reveal Side	All			X			Windshield Reveal Lower	
Windshield Reveal Lower	All			X				Cowl Air Intake Grille
Windshield Pillar Drip	35, 37, 39, 69, 57	X						Windshield Pillar Weatherstrip and Weatherstrip Retainer (37, 39, 57 styles only)
Windshield Pillar Finishing	67	X					Windshield Side Reveal	Windshield Pillar Weatherstrip and Weatherstrip Retainer
Roof Drip Molding Scalp	37, 69		X				Windshield Pillar Drip Molding	
Roof Drip Molding Scalp Front	35, 39, 57		X				Windshield Pillar Drip Molding	
Roof Drip Molding Scalp Rear	35, 39, 57	X (57 only)	X				Roof Drip Molding Scalp Front	
Roof Panel Ornament	39							Headlining Rear Quarter Trim
Roof Panel Name Plate	39, 69							Headlining Rear Quarter Trim

25200 - 25400 - 25600 - 26200 - 26600 SERIES (Cont'd.)

Molding Name	Series Or Styles	Method of Retention					Engages With Other Moldings	Remove Hardware Or Trim
		Screws	Spring (Self-Retained)	Snap-On Clips Or Retainers On Panel	Snap-On Clips On Moldings	Studs With Attaching Nuts		
Front Door Window Frame Front Scalp	11, 35, 45, 69		X				Front Door Window Frame Front Scalp	
Front Door Window Frame Upper Scalp	11, 35, 45, 69		X				Front Door Window Frame Upper Scalp	
Front Door Window Frame Rear Scalp	11, 35, 45, 69		X					
Front Door Window Belt Reveal (at vent)	All	X						Front Door Vent Assembly (11, 35, 45, 69 Styles only) Door Trim Pad (37, 57, 39, 67 Styles)
Front Door Window Belt Reveal	57	X					Front Door Window Reveal (at vent)	Rubber Bumper on Door Glass Lower Stop
Rear Door Window Frame Front Scalp	35, 45, 69		X				Rear Door Window Frame Upper Scalp	
Rear Door Window Frame Upper Scalp	35, 45, 69		X				Rear Door Window Frame Rear Scalp	
Rear Door Window Frame Rear Scalp	35, 45		X					
Quarter Window Upper Scalp	11			X				



25200 - 25400 - 25600 - 26200 - 26600 SERIES (Cont'd.)

Molding Name	Series Or Styles	Method of Retention					Engages With Other Moldings	Remove Hardware Or Trim
		Screws	Spring (Self-Retained)	Snap-On Clips Or Retainers On Panel	Snap-On Clips On Moldings	Studs With Attaching Nuts		
Quarter Window Front Scalp	11			X			Quarter Window Upper Reveal	Quarter Window Glass Lower Stop
Quarter Window Lower Belt Reveal	57	X					Roof Drip Molding Rear Scalp Quarter Window Lower Reveal	
Quarter Window Lower Belt Reveal Escutcheon	57		X					
Quarter Belt Reveal Front	57			X	X	X	Quarter Belt Reveal Rear	Headlining Rear Quarter Trim Panel
Quarter Belt Reveal Rear	57	X				X	Quarter Belt Reveal Front	
Quarter Belt Reveal	11, 39, 69			X		X		
Quarter Belt Reveal	37						Right Side Overlaps Left Side	Headlining Rear Quarter Trim Panel
Quarter Pinch Weld Finishing Molding	67						Right Side Overlaps Left Side	
Quarter Window Reveal Upper	35, 45	X					Quarter Window Reveal Lower	
Quarter Window Reveal Lower	35, 45			X			Quarter Window Reveal Lower Escutcheon	

25200 - 25400 - 25600 - 26200 - 26600 SERIES (Cont'd.)

Molding Name	Series Or Styles	Method of Retention					Engages With Other Moldings	Remove Hardware Or Trim
		Screws	Spring (Self-Retained)	Snap-On Clips Or Retainers On Panel	Snap-On Clips On Moldings	Studs With Attaching Nuts		
Quarter Window Reveal Lower Escutcheon	35, 45			X			Quarter Window Reveal Upper and Lower	
Front Door Outer Panel	25200-25400 25600	X		X				
Front Door Outer Panel	26200	X				X		Remove Door Trim
Rear Door Outer Panel	25200-25600	X		X				
Rear Door Outer Panel	26200	X				X		Remove Door Trim
Rear Quarter Outer Panel	25200-25600			X				
Front of Rear Wheel Opening	25400-26600			X				
Rear of Rear Wheel Opening	25400-26600			X				
Rear of Rear Wheel Opening	26200	X						
Rear Quarter Outer Panel Emblem and/or Nameplate	All Except 26200							
Back Window Reveal Upper	All (except 35, 45, 67)			X			Back Window Reveal Side	
Back Window Reveal Side	All (except 35, 45, 67)			X			Back Window Reveal Lower	

25200 - 25400 - 25600 - 26600 SERIES (Cont'd.)

Molding Name	Series Or Styles	Method of Retention					Engages With Other Moldings	Remove Hardware Or Trim
		Screws	Spring (Self-Retained)	Snap-On Clips Or Retainers On Panel	Snap-On Clips On Moldings	Studs With Attaching Nuts		
Back Window Reveal Lower	All (except 35, 45, 67)			X			Back Window Reveal Side	
Back Body Opening Reveal Upper	35, 45	X					Back Body Opening Reveal Side	Tailgate Glass Run Channel
Back Body Opening Reveal Side	35, 45	X					Back Body Opening Reveal Upper	
Tailgate Window Reveal	35, 45	X			X			Tailgate Window and Regulator
Tailgate Outer Panel Belt Reveal (Optional)	35, 45	X			X			
Tailgate Outer Panel Nameplate	35, 45					X		
Tailgate Outer Panel Lower	35, 45					X		
Back Body Pillar Belt Reveal (Optional)	35, 45					X		
Rear Compartment Lid Outer Panel Emblem and/or Nameplate	All (except 35, 45)							X
Rear End Panel	26657							X
Rear End Panel Nameplate	25200-25400 25600							X

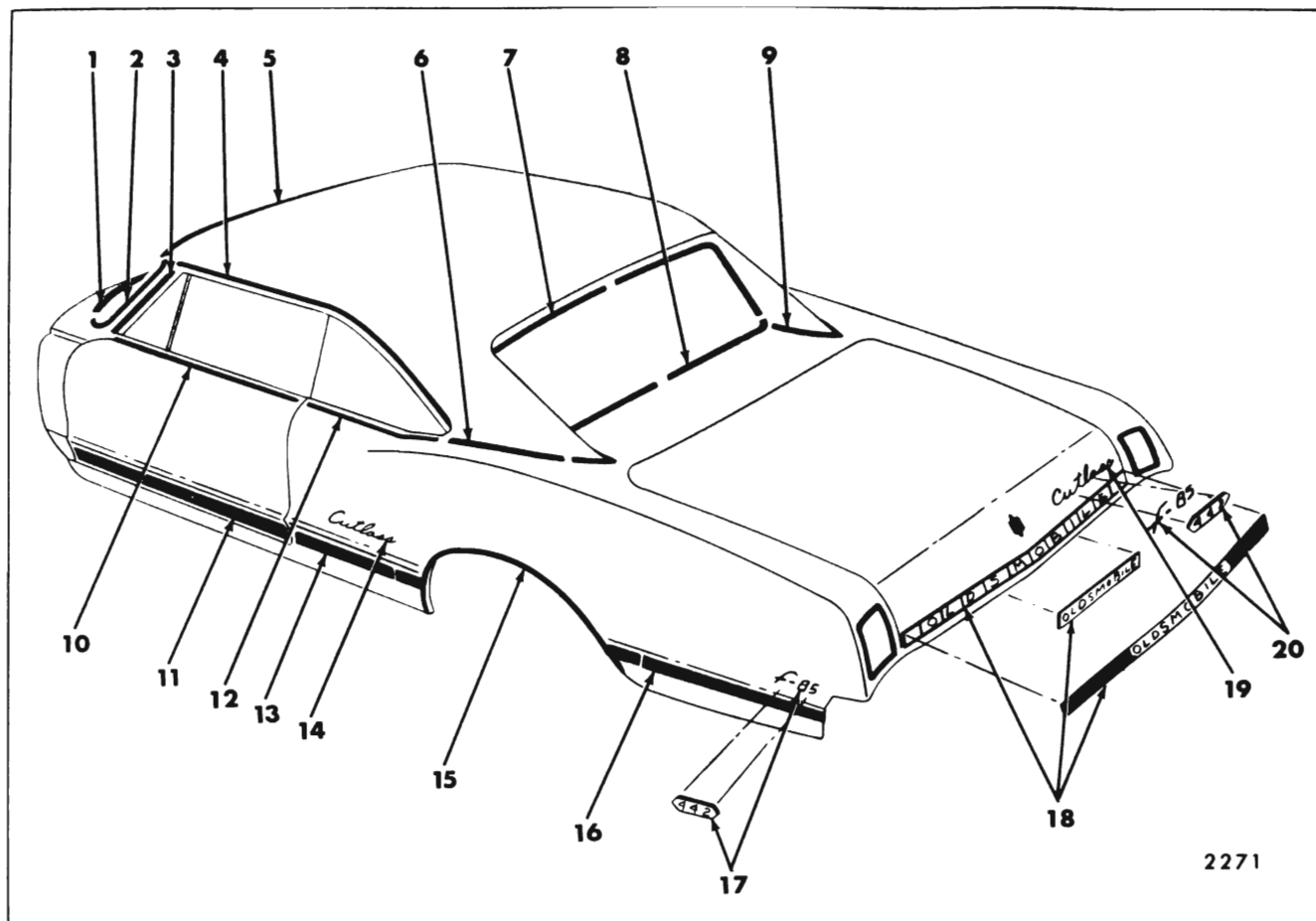

2271

Fig. 12-22—F-85 "A-17" Styles

1. Windshield Reveal Lower Molding
2. Windshield Reveal Side Molding
3. Windshield Pillar Finishing Molding
4. Roof Drip Molding Scalp
5. Windshield Reveal Upper Molding
6. Rear Quarter Belt Reveal Molding
7. Back Window Reveal Upper Molding
8. Back Window Reveal Lower Molding
9. Rear Quarter Belt Reveal Rear Molding
10. Front Door Window Belt Reveal Molding
11. Front Door Outer Panel Molding
12. Rear Quarter Window Belt Reveal Molding
13. Front of Rear Wheel Opening Molding
14. Rear Quarter Outer Panel Nameplate
15. Rear Wheel Opening Molding
16. Rear of Rear Wheel Opening Molding
17. Rear Quarter Outer Panel Emblem
18. Rear Compartment Lid Outer Panel Molding
19. Rear Compartment Lid Outer Panel Nameplate
20. Rear Compartment Lid Outer Panel Emblem

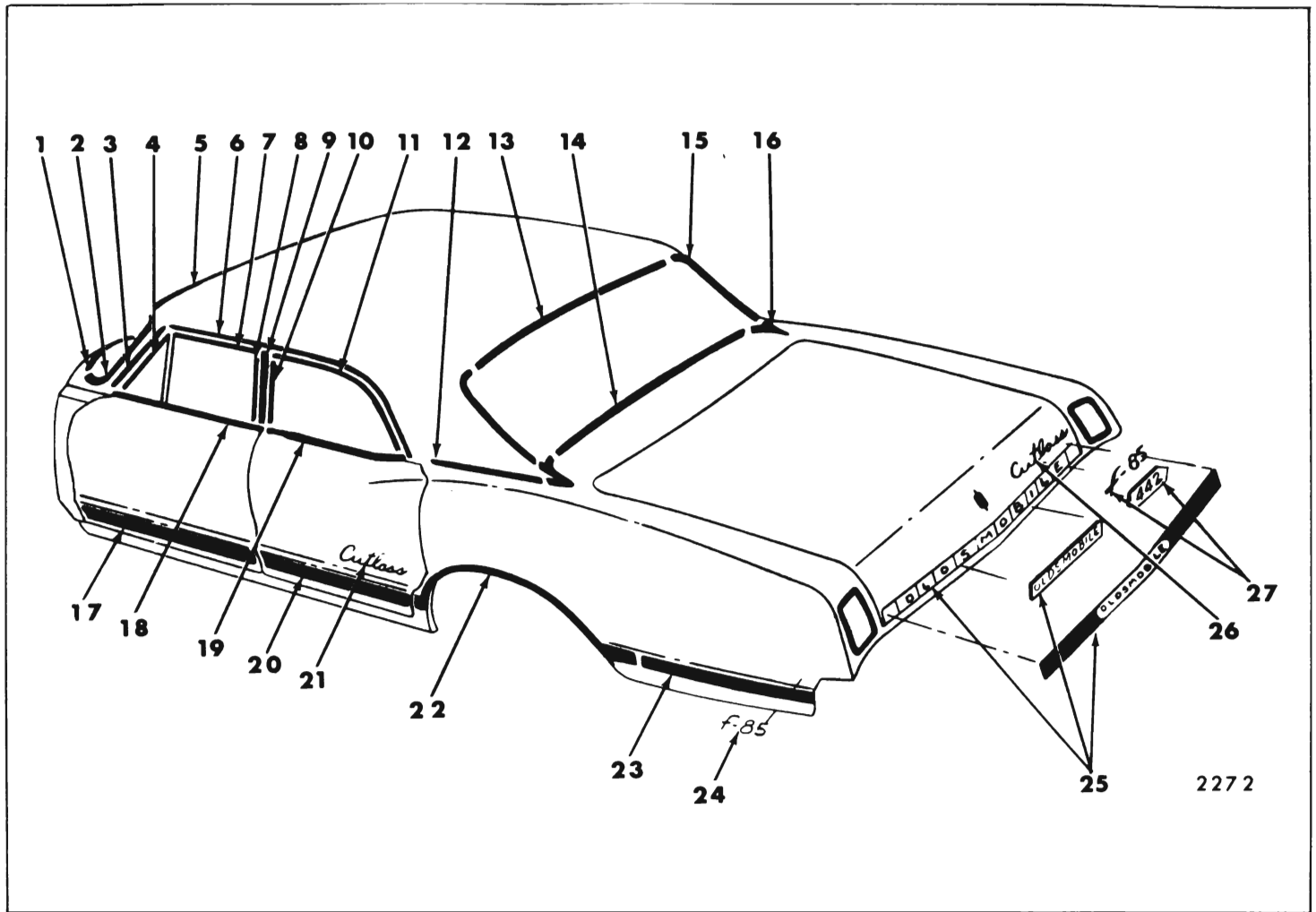

Fig. 12-23—F-85 "A-69" Styles

- |  |  |
|--|--|
| 1. Windshield Reveal Lower Molding             | 15. Back Window Reveal Side Molding            |
| 2. Windshield Reveal Side Molding              | 16. Rear Quarter Belt Reveal Rear Molding      |
| 3. Windshield Pillar Finishing Molding         | 17. Front Door Outer Panel Molding             |
| 4. Front Door Window Frame Front Scalp Molding | 18. Front Door Window Belt Reveal Molding      |
| 5. Windshield Reveal Upper Molding             | 19. Rear Door Window Belt Reveal Molding       |
| 6. Roof Drip Molding Scalp                     | 20. Rear Door Outer Panel Molding              |
| 7. Front Door Window Frame Upper Scalp Molding | 21. Rear Door Outer Panel Nameplate            |
| 8. Front Door Window Frame Rear Scalp Molding  | 22. Rear Wheel Opening Molding                 |
| 9. Center Pillar Scalp Molding                 | 23. Rear of Rear Wheel Opening Molding         |
| 10. Rear Door Window Frame Front Scalp Molding | 24. Rear Quarter Outer Panel Emblem            |
| 11. Rear Door Window Frame Upper Scalp Molding | 25. Rear Compartment Lid Outer Panel Molding   |
| 12. Rear Quarter Belt Reveal Molding           | 26. Rear Compartment Lid Outer Panel Nameplate |
| 13. Back Window Reveal Upper Molding           | 27. Rear Compartment Lid Outer Panel Emblem    |
| 14. Back Window Reveal Lower Molding           |  |

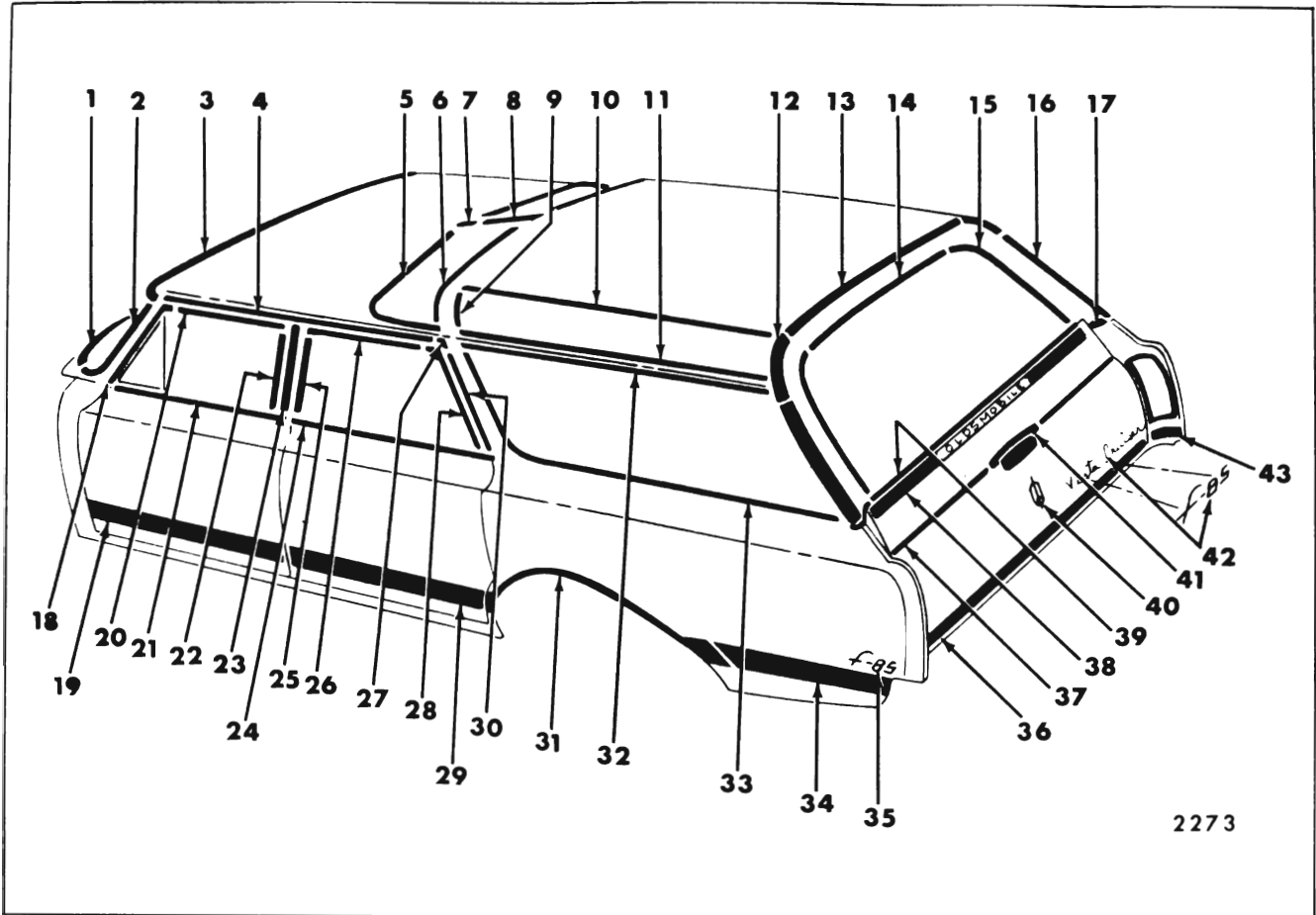

Fig. 12-24-F-85 "55-65" Styles

- |   |  |
|---|--|
| 1. Windshield Reveal Lower Molding                        | 23. Center Pillar Scalp Molding                    |
| 2. Windshield Reveal Side Molding                         | 24. Rear Door Window Belt Reveal Molding           |
| 3. Windshield Reveal Upper Molding                        | 25. Rear Door Window Frame Front Scalp Molding     |
| 4. Roof Drip Molding Front Scalp                          | 26. Rear Door Window Frame Upper Scalp Molding     |
| 5. Front Skylight Front Reveal Molding                    | 27. Roof Drip Molding Scalp Escutcheon             |
| 6. Front Skylight Rear Reveal Molding                     | 28. Rear Door Window Frame Rear Scalp Molding      |
| 7. Front Skylight Center Division Reveal Lower Escutcheon | 29. Rear Door Outer Panel Molding                  |
| 8. Front Skylight Center Division Reveal Molding          | 30. Roof Drip Molding Rear Scalp                   |
| 9. Side Skylight Front Reveal Molding                     | 31. Rear Wheel Opening Molding                     |
| 10. Side Skylight Upper Reveal Molding                    | 32. Rear Quarter Window Reveal Upper Molding       |
| 11. Side Skylight Lower Reveal Molding                    | 33. Rear Quarter Window Reveal Lower Molding       |
| 12. Rear Upper Side Finishing Molding                     | 34. Rear of Rear Wheel Opening Molding             |
| 13. Rear Upper Finishing Molding                          | 35. Rear Quarter Outer Panel Emblem                |
| 14. Back Body Opening Upper Reveal Molding                | 36. Tailgate Outer Panel Lower Molding             |
| 15. Back Body Opening Side Reveal Molding                 | 37. Tailgate Outer Panel Upper Molding             |
| 16. Rear Lower Side Finishing Molding                     | 38. Tailgate Outer Panel Belt Molding              |
| 17. Back Body Pillar Belt Finishing Molding               | 39. Tailgate Window Lower Reveal Molding           |
| 18. Front Door Window Frame Front Scalp Molding           | 40. Tailgate Outer Panel Emblem                    |
| 19. Front Door Outer Panel Molding                        | 41. Tailgate Outer Panel Upper Molding (At Handle) |
| 20. Front Door Window Frame Upper Scalp Molding           | 42. Tailgate Outer Panel Nameplate                 |
| 21. Front Door Window Belt Reveal Molding                 | 43. Rear of Rear Quarter Outer Panel Molding       |
| 22. Front Door Window Frame Rear Scalp Molding            |  |

33400 - 33600 - 33800 SERIES

Molding Name	Series Or Styles	Method of Retention						Engages With Other Moldings	Remove Hardware Or Trim
		Screws	Spring (Self-Retained)	Snap-On Clips Or Retainers On Panel	Snap-On Clips On Moldings	Studs With Attaching Nuts			
Windshield Reveal Upper	All			X			Windshield Reveal Side	Windshield Reveal Upper	
Windshield Reveal Side	All			X			Windshield Reveal Lower	Windshield Reveal Upper	
Windshield Reveal Lower	All			X			Windshield Reveal Side	Windshield Reveal Side	
Windshield Pillar Finishing	All	X						Windshield Pillar Weatherstrip and Weatherstrip Retainer (37, 67 Styles Only)	
Roof Drip Molding Scalp Front	All Except 67		X				Roof Drip Molding Scalp Escutcheon		
Roof Drip Molding Scalp Rear	All Except 67		X				Roof Drip Molding Scalp Escutcheon		
Roof Drip Molding Scalp Escutcheon	All Except 67		X						
Front Door Window Frame Front Scalp	07, 35, 55, 65, 69		X				Front Door Window Frame Front Scalp		
Front Door Window Frame Upper Scalp	07, 35, 55, 65, 69		X				Front Door Window Frame Front Scalp		
Front Door Window Frame Rear Scalp	07, 35, 55, 65, 69		X				Front Door Window Frame Upper Scalp		
Front Door Window Belt Reveal	All	X						Front Door Window Lower Stops	

33400 - 33600 - 33800 SERIES (Cont'd.)

Molding Name	Series Or Styles	Method of Retention						Engages With Other Moldings	Remove Hardware Or Trim
		Screws	Spring (Self-Retained)	Snap-On Clips Or Retainers On Panel	Snap-On Clips On Moldings	Studs With Attaching Nuts			
Center Pillar Scalp	35, 55, 65, 69	X							
Rear Door Window Frame Scalp Front	35, 55, 65, 69		X				Rear Door Window Upper Scalp		
Rear Door Window Frame Scalp Upper	35, 55, 65, 69		X				Rear Door Window Frame Rear Scalp		
Rear Door Window Frame Scalp Rear	35, 55, 65, 69		X						
Rear Door Window Belt Reveal	35, 55, 65, 69	X						Rear Door Window Lower Stops	
Quarter Window Front Scalp	07			X			Quarter Window Upper Reveal		
Quarter Window Upper Scalp	07			X					
Quarter Window Belt Reveal	07, 37, 67	X						Quarter Window Lower Stop	
Quarter Belt Reveal	07, 37								
Quarter Pinchweld Finishing	67	X		X				Rear Quarter and Rear End Trim Sticks	
Rear End Pinchweld	67	X		X			Quarter Pinchweld Finishing Quarter Window Lower Reveal Molding	Rear Quarter and Rear End Trim Sticks	



33400 - 33600 - 33800 SERIES (Cont'd.)

Molding Name	Series Or Styles	Method of Retention					Engages With Other Moldings	Remove Hardware Or Trim
		Screws	Spring (Self-Retained)	Snap-On Clips Or Retainers On Panel	Snap-On Clips On Moldings	Studs With Attaching Nuts		
Front Skylight Front Reveal	55, 65			X			Front Skylight Front Reveal	
Front Skylight Rear Reveal	55, 65			X			Front Skylight Front Reveal	
Front Skylight Center Division Reveal Lower Escutcheon	55, 65			X			Front Skylight Front Reveal and Center Division Reveal	
Front Skylight Center Division Reveal	55, 65			X			Front Skylight Rear Reveal	
Side Skylight Front Reveal	55, 65			X			Side Skylight Lower Reveal	
Side Skylight Upper Reveal	55, 65			X			Side Skylight Front Reveal	
Side Skylight Lower Reveal	55, 65			X			Quarter Window Reveal Upper	Loosen Quarter Window Reveal Upper and Lower at Corner
Quarter Window Reveal Upper Corner Escutcheon	35			X			Quarter Window Reveal Upper and Lower Corner Escutcheon	Quarter Window Reveal Upper Corner Escutcheon
Quarter Window Reveal Lower	35			X			Quarter Window Reveal Upper and Lower Corner Escutcheon	Quarter Window Reveal Lower Corner Escutcheon

33400 - 33600 - 33800 SERIES (Cont'd.)

Molding Name	Series Or Styles	Method of Retention					Engages With Other Moldings	Remove Hardware Or Trim
		Screws	Spring (Self-Retained)	Snap-On Clips Or Retainers On Panel	Snap-On Clips On Moldings	Studs With Attaching Nuts		
Quarter Window Reveal Lower Corner Escutcheon	35			X			Quarter Window Reveal Lower	Loosen Quarter Window Reveal Upper and Lower at Corner
Quarter Window Reveal Upper	55, 65			X				
Quarter Window Reveal Lower	55, 65			X				
Roof Panel Rear Upper Finishing	55, 65				X			Rear Roof Headlining Trim Finish Molding
Rear Upper Side Finishing	55, 65					X		
Rear Lower Side Finishing	55, 65				X			
Front Door Outer Panel	33800				X			
Rear Door Outer Panel	33800				X			
Front of Rear Wheel Opening	33800	X					Rear Wheel Opening	Quarter Trim Pad
Rear Wheel Opening	33800	X						
Rear of Rear Wheel Opening	33800	X			X		Rear Wheel Opening	
Rear Quarter Outer Panel Nameplate and/or Emblem	All							
Rear Compartment Lid Outer Panel	All							
Rear Compartment Lid Outer Panel Emblem	All							