

SECTION 10-E CRANKING (STARTER) SYSTEM

CONTENTS OF SECTION 10-E

Paragraph	Subject	Page	Paragraph	Subject	Page
10-31	The Cranking (Starter) System.....	10-37	10-37	Voltage Text of Cranking Motor and Solenoid Switch	10-49
10-32	Accelerator Vacuum Switch—On Carter Carburetor.....	10-39	10-38	Test and Adjustment of Solenoid Switch Relay.....	10-49
10-33	Accelerator Vacuum Switch—On Stromberg Carburetor..	10-42	10-39	Solenoid Switch Test and Repairs—Cranking Motor on Bench.....	10-51
10-34	Neutral Safety Switch—Dynaflow Drive.....	10-45	10-40	Bench Test of Cranking Motor	10-52
10-35	Cranking Motor Assembly...	10-46	10-41	Cranking Motor Repairs—On Bench.....	10-53
10-36	Periodic Inspection of Cranking Motor.....	10-48			

SERVICE BULLETIN REFERENCE

Bulletin No.	Page No.	SUBJECT

10-31 THE CRANKING (STARTER) SYSTEM

a. General Description

The Buick cranking system permits the engine to be cranked and started automatically, after the ignition has been turned on, by pressing down on the accelerator pedal. The cranking motor circuit is automatically opened and the cranking motor is disengaged from the flywheel ring gear as soon as the engine starts running and the accelerator pedal is released.

The units comprising the cranking system (fig. 10-32) are as follows:

1. Battery and battery cables (par. 10-14).
2. Cranking motor, including the drive assembly which engages the flywheel ring gear during cranking operation (par. 10-35).
3. Cranking motor solenoid switch, mounted on cranking motor, for shifting drive assembly and closing the motor circuit. The switch includes a relay for operating the solenoid (par. 10-35).
4. Accelerator vacuum switch, mounted on the carburetor and operated by both the throttle shaft and engine vacuum. This switch permits control of cranking system by the accelerator pedal (par. 10-32 and 10-33).
5. Generator windings, which are used for

completing the vacuum switch and solenoid relay magnet coil circuit to ground.

6. Charge indicator, ignition switch, and necessary wiring to connect the various units.

7. *Neutral safety switch, only on cars equipped with Dynaflow Drive.* This switch is connected in series with the solenoid switch relay to prevent cranking of engine except when the transmission control lever is in either the neutral (N) or parking (P) position.

b. Operation of Cranking System

After the ignition switch is turned on, the cranking system is set in operation to start the engine by pressing down on the accelerator pedal. This causes the throttle to open and the accelerator vacuum switch contacts to close, thereby allowing current to flow from the battery through the ignition switch, vacuum switch, solenoid switch relay windings, and generator windings to ground. See figure 10-32. **NOTE:** *On Dynaflow Drive cars, the transmission control lever must be in neutral (N) or parking (P) position so that neutral safety switch is closed.*

Completion of this control circuit causes the solenoid switch relay contacts to close. Current from the battery then flows through the "pull-

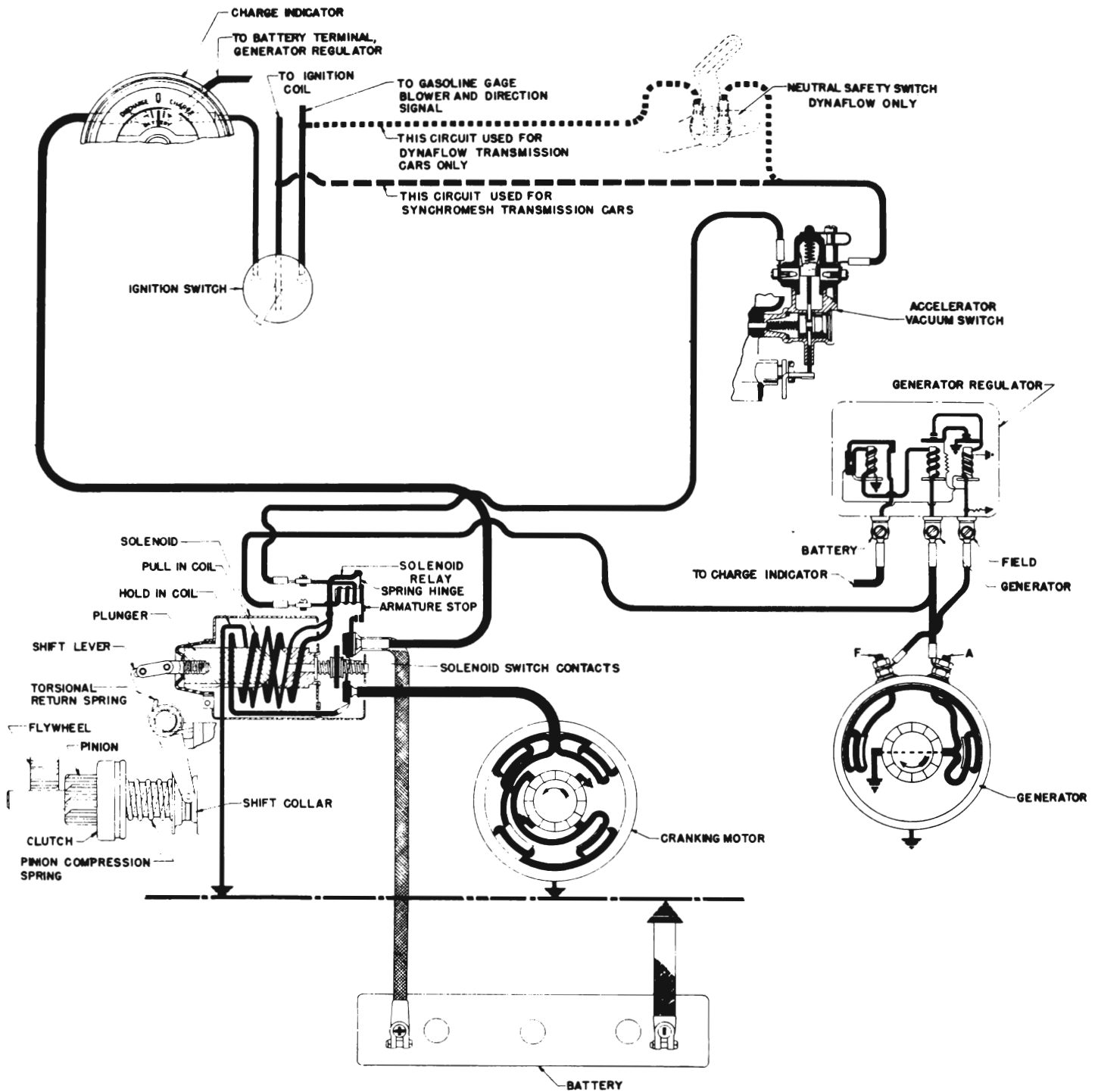

Figure 10-32—Cranking System Circuits

in" and "hold-in" coils of the solenoid, magnetizing the solenoid. The plunger is pulled into the solenoid so that it shifts the drive pinion into engagement with flywheel ring gear and closes the solenoid switch contacts.

The closing of the solenoid switch contacts causes the motor to crank the engine and also cuts out the "pull-in" coil of the solenoid, the magnetic pull of the "hold-in" coil being sufficient to hold the pinion in mesh after the shifting has been performed. This reduces the current consumed by the solenoid while the cranking motor is operating.

Normally, as soon as the engine starts running and accelerator pedal is released, the manifold vacuum causes the accelerator vacuum switch to break contact and open the relay circuit. This causes the solenoid switch relay contacts to open, which breaks the solenoid circuit. A return spring on the shift lever stud allows the solenoid switch to open and then disengages the drive pinion from flywheel ring gear.

Under conditions where the throttle does not return to idle position, or engine vacuum is not sufficient to cause the accelerator vacuum switch to break contact, the increased speed of the

generator results in generating a voltage which prevents the current passing through the magnet coil of the solenoid switch relay from continuing its flow through the generator to ground, therefore the relay points open to break the solenoid circuit.

In cold weather, if the first explosions are too feeble to keep the engine turning over, the manifold vacuum is not sufficient to cause the accelerator vacuum switch to break contact, and neither does the generator develop sufficient voltage to cause the relay points to open. The cranking system therefore remains in operation until the explosions are strong enough to keep the engine running.

When the engine is running, there are three separate means of preventing the cranking system from being operated by movement of the accelerator pedal: (1) Manifold vacuum acting on accelerator vacuum switch. (2) Mechanical lockout in the accelerator vacuum switch. (3) Blocking effect of generator voltage on solenoid relay.

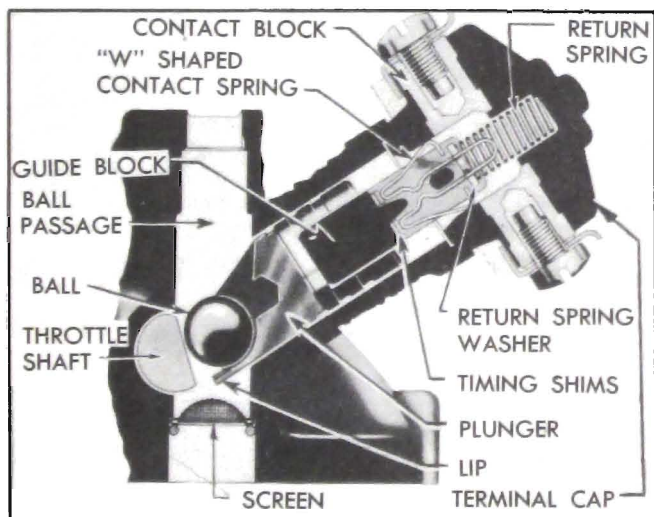

Figure 10-33—Carter Accelerator Vacuum Switch—Engine Not Running

throttle shaft. The plunger, guide block, and contact spring are held in a down position by the return spring so that the contact spring does not make contact with the contact blocks in terminal cap. See figure 10-33.

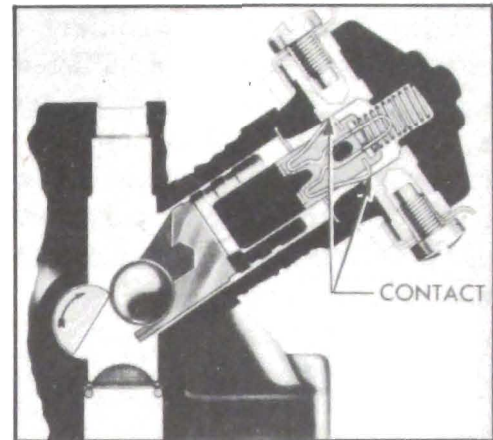

Figure 10-34—Carter Accelerator Vacuum Switch—Cranking Position

When the accelerator is depressed with engine stopped and ignition switch turned on, the flat spot on throttle shaft acts as a cam to push the switch ball, plunger, guide block, and contact spring upward until the contact spring makes contact with both contact blocks in terminal cap. This closes the solenoid relay circuit and puts the cranking system into operation. See figure 10-34.

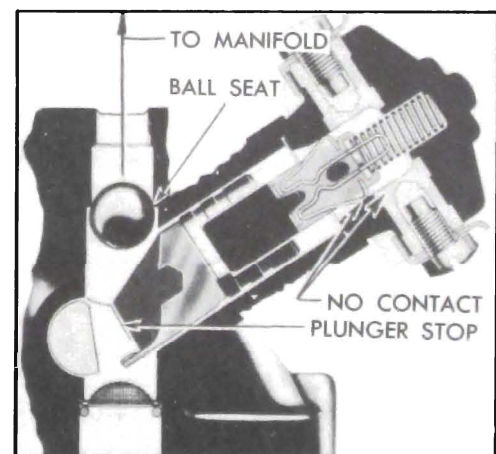

Figure 10-35—Carter Accelerator Vacuum Switch—Engine Running

10-32 ACCELERATOR VACUUM SWITCH — ON CARTER CARBURETOR

a. Description and Operation

The accelerator vacuum switch used on the Carter carburetor is built into the throttle body in position to be operated by the throttle shaft.

The switch consists of a special stainless steel ball, plunger, guide block, W-shaped contact spring, and return spring housed in a passage in throttle body which is closed by a terminal cap containing two contact blocks. When the engine is not running and throttle is closed, the ball rests on a lip on the lower end of switch plunger and bears against a flat spot on the

When the engine starts, manifold vacuum acts on the switch ball and as soon as the accelerator pedal is released the ball is drawn upward away from throttle shaft. The return spring then pushes the contact spring downward, thus breaking the circuit and causing the cranking system to stop operating. See figure 10-35. As long as engine continues running the switch ball is held against its seat in throttle body by manifold vacuum, therefore movement

of throttle cannot cause switch to make contact. As soon as engine stops, the ball drops to the starting position.

It is very important that switch contact is made when throttle valve is opened between 30 to 45 degrees, to assure proper starting conditions. If the switch makes contact too early the throttle will not be opened sufficient to give a good cold start. If the switch makes contact too late the throttle will be opened too far, which may cause gear clash as well as hard starting due to unloading of carburetor choke by the throttle mechanism. See subparagraph *b*, below.

throttle stop screw to give engine idle speed (hot) of 450 RPM, which is equivalent to 8 MPH on level road in third speed.

c. Checking Switch Timing with Carburetor Removed from Engine

When carburetor is removed from engine it is preferable to check vacuum switch timing by use of Carter Indicator Gauge T 109-155 S. If this gauge is not available, the switch timing may be checked by the method described above (subpar. *b*), after connecting a 6-volt battery and test lamp in series with switch terminals to indicate point of contact.

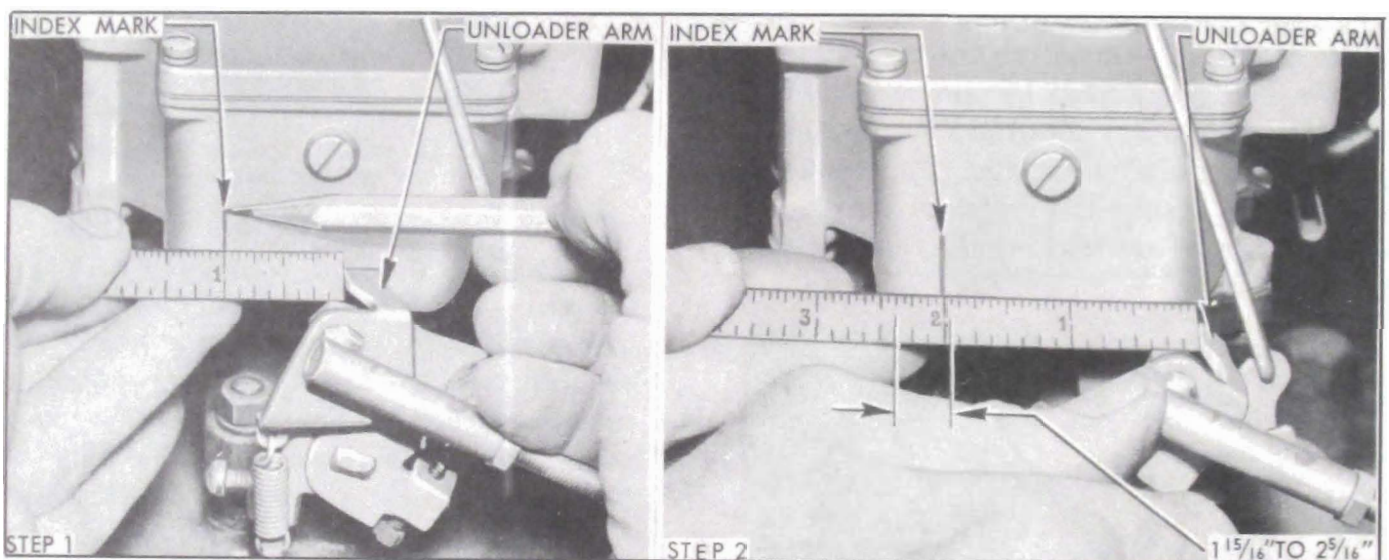

Figure 10-36—Checking Carter Accelerator Vacuum Switch Timing with Carburetor Installed

b. Checking Switch Timing with Carburetor Installed on Engine

CAUTION: Before checking timing be sure transmission is in neutral and apply parking brake.

1. Back off throttle stop screw, rotate fast idle cam to slow idle position if necessary, and fully close the throttle valve.

2. While holding throttle valve fully closed, place a scale against choke unloader arm of throttle lever and make an index mark on float bowl at the one inch division on scale. See figure 10-36, step 1.

3. Turn ignition switch "ON", and slowly push the scale against unloader arm to open throttle until the drive pinion just engages fly-wheel ring gear.

4. If switch is correctly timed, the scale will then read between $1\frac{5}{16}$ " and $2\frac{5}{16}$ " at mark on fuel bowl ($1\frac{5}{16}$ " to $1\frac{5}{16}$ " travel). See figure 10-36, step 2.

5. If necessary, retune switch as described below (subpar. *d*). If timing is correct adjust

Checking switch timing with Gauge T 109-155 S is as follows:

1. Attach protractor scale of gauge to the choke thermostat housing. Remove throttle

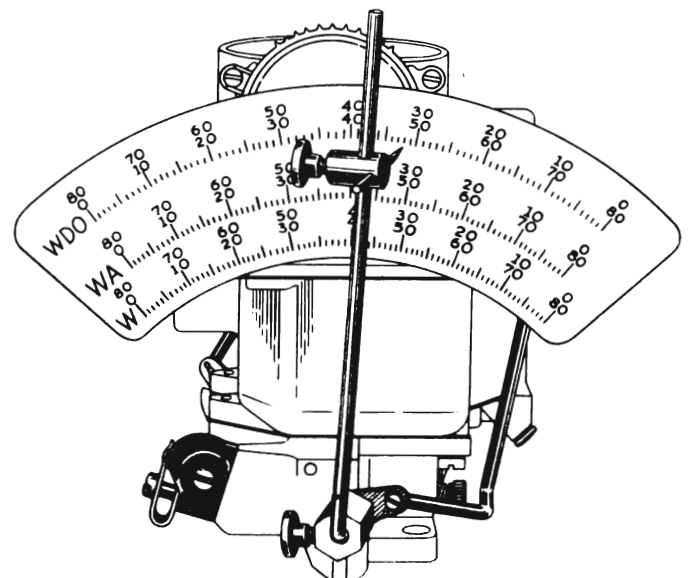

Figure 10-37—Carter Indicator Gauge T 109-155 S

shaft arm screw and attach pointer to end of throttle shaft. See figure 10-37.

2. Back off throttle stop screw and fast idle adjusting screw, and hold throttle valve fully closed. Adjust gauge pointer so that it is at zero on the "WCD" (top) scale, and tighten securely.

3. Connect 6-volt battery and test lamp in series with vacuum switch terminals, to indicate point of contact.

4. Slowly open throttle valve and note reading on "WCD" scale at instant that test lamp lights. Gauge pointer will be between 30 to 45 degrees if switch is correctly timed.

5. If necessary, retune switch as described below (subpar. d).

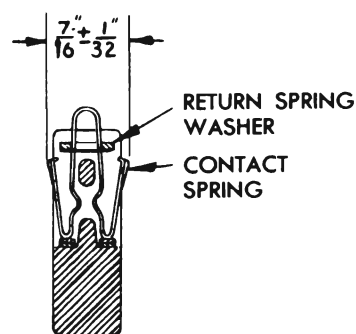

Figure 10-39—Contact Spring Dimension

5. The free length of switch return spring is $\frac{1}{16}$ " to $\frac{3}{4}$ ". Pressure of 32 ounces should be required to compress spring to length of $\frac{3}{8}$ ". Replace a weak or distorted spring; do not stretch or alter spring as switch operation will be affected.

6. The contact spring rests on a number of square brass shims which control the switch timing. If switch timing was found to be too early (subpar. b or c, above), reduce the total

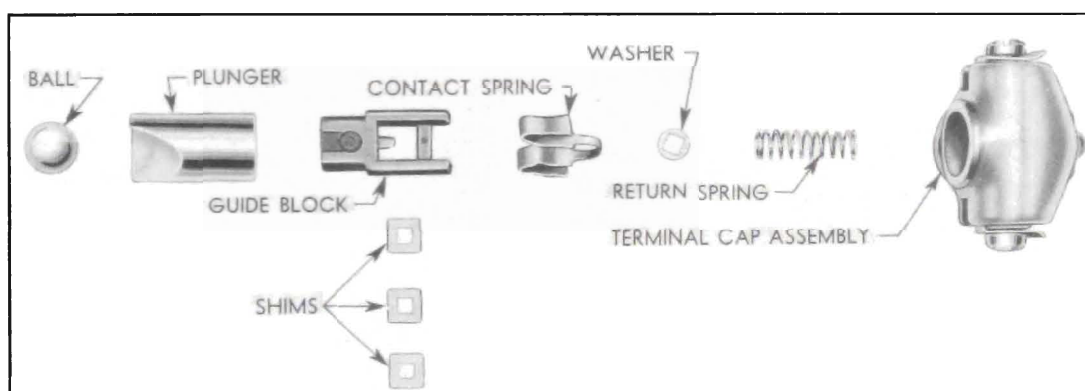

Figure 10-38—Carter Accelerator Vacuum Switch Disassembled

d. Cleaning and Timing Vacuum Switch

Switch timing may be changed without removing carburetor from engine; however if switch is dirty the carburetor should be removed so that switch passages can be properly cleaned.

1. Disconnect wires from terminals. Hold down on switch terminal cap while removing hold down clip. Remove terminal cap and return spring, then lift out switch guide block with contact spring and shims. Do not lose timing shims and the spring washer on contact spring. See figure 10-38.

2. Remove plunger and steel ball from carburetor body flange.

3. Wash all metal parts in clean white gasoline and wipe dry. Clean out passages in carburetor body flange if dirty. Do not soak terminal cap and guide block in cleaning solution, but wipe with a clean cloth.

4. Check condition of contact spring and replace it if burned or otherwise damaged. The free width of spring across the points, with return spring washer in place, is shown in figure 10-39.

thickness of these shims. If timing was too late, increase total thickness of shims. These shims are furnished in thicknesses of .006" and .018".

7. Before installing parts, the contact surfaces in terminal cap should be given a *light* coating of Standard Oil Rocker Arm Grease No. 1 or Beacon M-285 lubricant. If these lubricants are not available petroleum jelly may be used. Work lubricant into a piece of clean cloth and lightly swab the inside of terminal

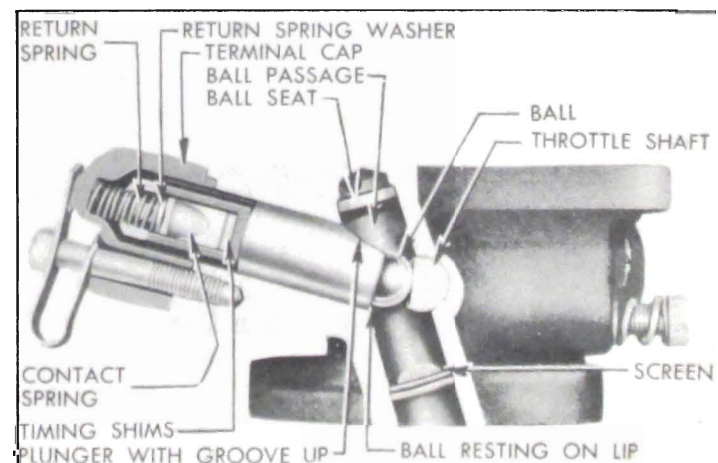

Figure 10-40—Carter Accelerator Vacuum Switch Correctly Assembled

cap. CAUTION: Do not use ordinary lubricants as poor switch contact will be obtained in cold weather. Do not apply lubricant to the ball or plunger.

8. Place plunger in position with the groove up so that the ball rests on lip at inner end of plunger. See figure 10-40. If the plunger is installed with groove down, as shown in figure 10-41, the ball will be prevented from rising into the ball passage when the engine starts. As a result, the switch will close each time the throttle is opened, causing gear clash at low speeds when the generator is not producing sufficient voltage to open the solenoid relay. If generator should be inoperative, gear clashing would occur at all speeds.

9. Make sure that all timing washers, contact spring, and the return spring washer are in proper position before installing the return spring and terminal cap. Make sure that terminal cap is properly seated. See figure 10-40.

10. After switch is assembled, check the timing as described above (subpar. b or c), and change shims as required until proper timing is obtained.

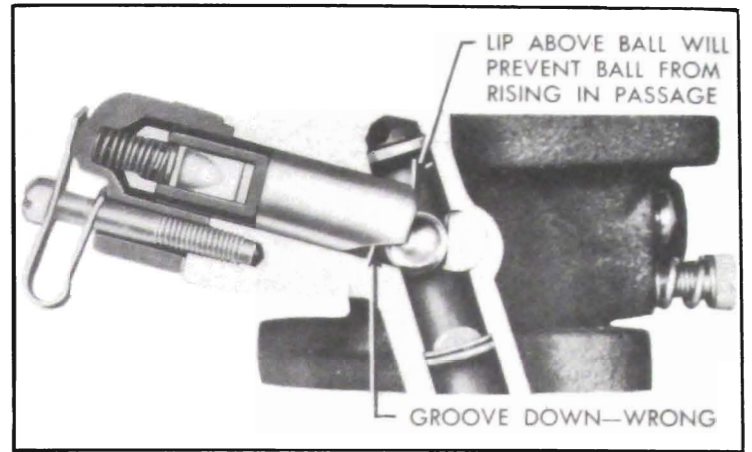

Figure 10-41—Carter Accelerator Vacuum Switch Incorrectly Assembled

the engine manifold is applied at one end by means of cored and drilled passages in the carburetor bodies. This end of the barrel is provided with a washer which forms a seal to prevent leaks when a piston opposed by a light spring is drawn against it by vacuum. The opposite end of the barrel is vented to outside air through a fine mesh screen which is held in place by a screen clip. A flat slide, actuated by an operating lever on the throttle shaft, moves in a confined slot in the housing and in a plane perpendicular to the axis of the cylinder barrel. This slide engages a cylindrical bakelite contact guide, the upward movement of which is opposed by a heavy contact guide spring. The contact guide carries a thin U-shaped spring contact which moves up and down within a bakelite terminal cap to engage stationary contacts for opening and closing the cranking motor control circuit. The terminal cap is held in place by a cap screw and cap clip. See figure 10-42.

10-33 ACCELERATOR VACUUM SWITCH — ON STROMBERG CARBURETOR

a. Description and Operation

The accelerator vacuum switch used on Stromberg carburetors is mounted on the throttle body of the carburetor by two screws. A gasket placed between the switch housing and the throttle body seals against loss of vacuum.

The switch housing is provided with a horizontal cylinder barrel to which vacuum from

Figure 10-42 shows the accelerator vacuum

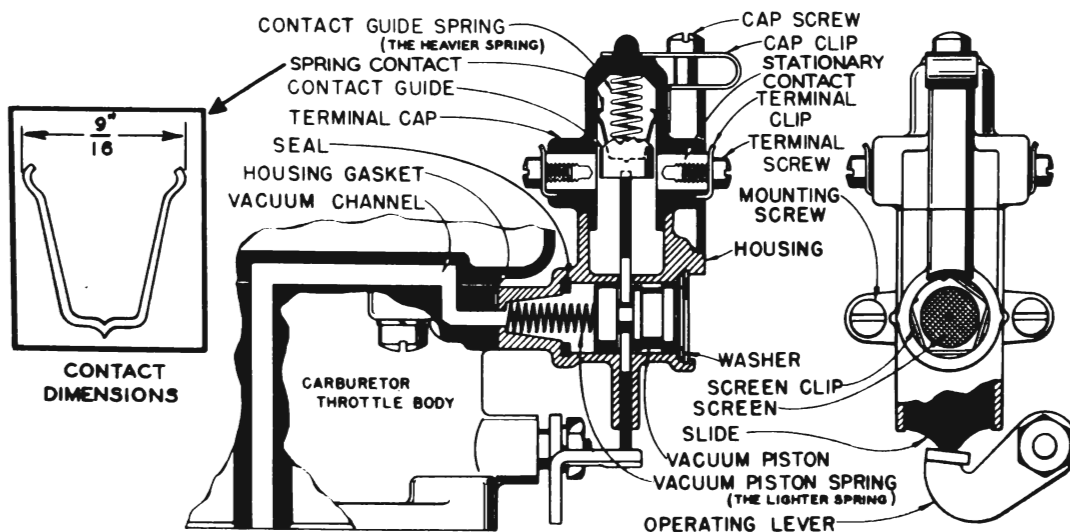

Figure 10-42—Stromberg Accelerator Vacuum Switch—Engine Not Running

switch with engine not running. The throttle is closed and the switch operating lever holds the slide in the upper position, thereby holding the U-shaped spring contact away from the stationary contacts in the terminal cap.

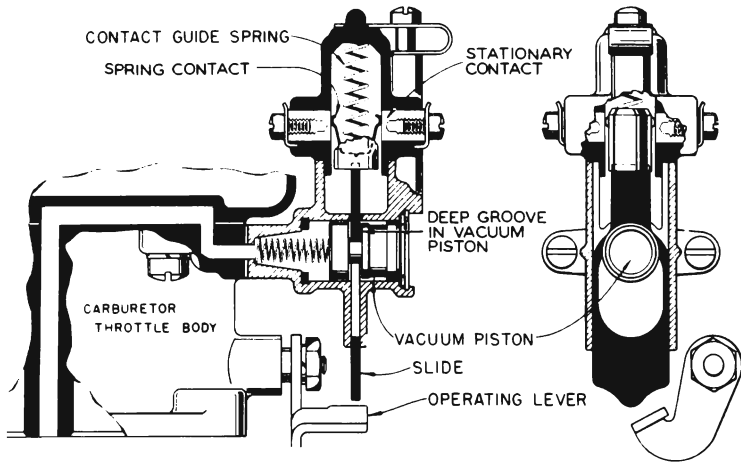

Figure 10-43—Stromberg Accelerator Vacuum Switch—Cranking Position

Pressing down on the accelerator pedal causes the operating lever to move away from the slide. This allows the contact guide spring to move the slide and U-shaped spring contact down to a position to bridge the stationary contacts in the terminal cap, thus closing the circuit. The slide moves into the deeper of the two grooves in the vacuum piston which has been positioned against the screen by the vacuum piston spring. See figure 10-43.

When the throttle is opened beyond the idle range, the operating lever moves away from the slide which is then forced downward by the contact guide spring until it strikes the shallow groove in the vacuum piston. This acts as a

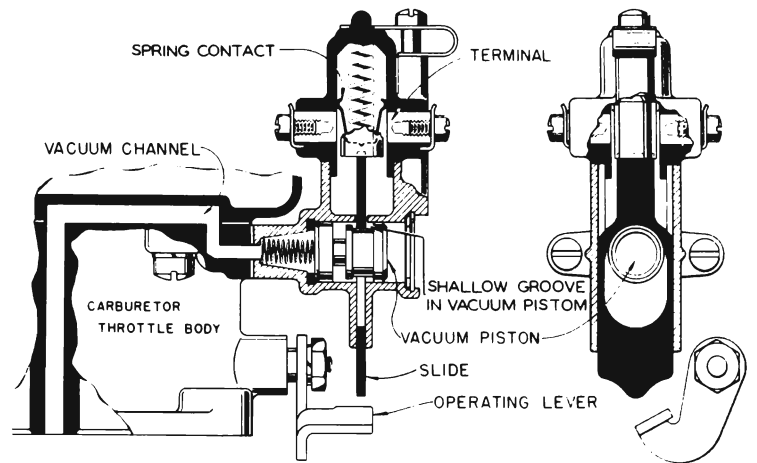

Figure 10-45—Stromberg Accelerator Vacuum Switch—Engine Running at Part or Open Throttle

stop and prevents the switch contacts from engaging while engine is running. It also holds the piston in the inner position when engine load conditions cause the vacuum to become too low to perform this function. See figure 10-45.

It is very important that the switch contact is made at a specific throttle opening, to assure proper starting conditions. If the switch makes contact too early the throttle will not be opened sufficiently to give a good start. If the switch makes contact too late the throttle will be opened too far, which may cause gear clash as well as hard starting due to unloading of carburetor choke by the throttle mechanism. See subparagraph *b*, below.

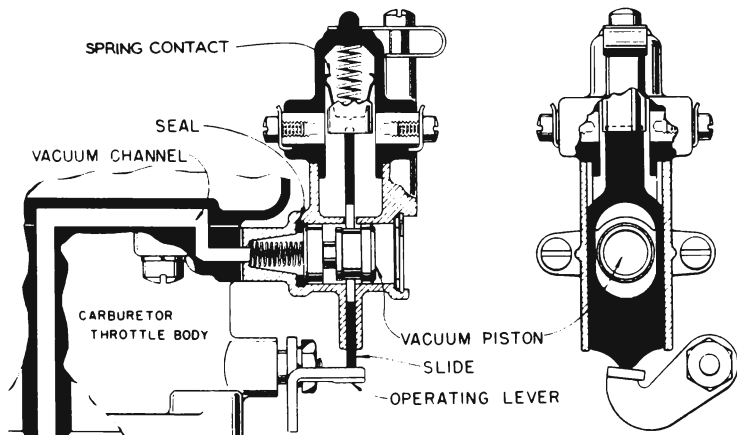

Figure 10-44—Stromberg Accelerator Vacuum Switch—Engine Running at Closed Throttle

When the engine starts and the throttle is allowed to close, the slide and U-shaped spring contact is moved upward by the switch operating lever, opening the circuit. With the slide in the up position, manifold vacuum pulls the vacuum piston inward until it seats against the seal. This aligns the shallow groove in piston with the slide. See figure 10-44.

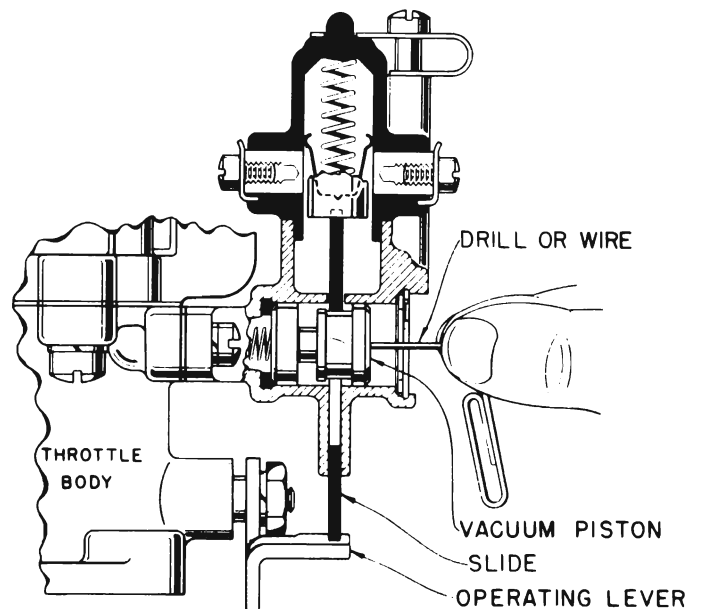

Figure 10-46—Pushing Vacuum Piston to Inner Position

b. Checking Switch Timing with Carburetor Installed on Engine

CAUTION: Before checking timing be sure that transmission is in neutral and apply parking brake.

1. Set engine hot idle speed at 450 RPM (8 MPH).
2. With engine not running insert #65 drill or wire (small size paper clip) through center of screen to operate vacuum piston. DO NOT REMOVE SCREEN. See figure 10-46.
3. With throttle closed, first push vacuum piston to its inner position and hold it there while opening throttle. This will allow slide to drop into the shallow groove in the piston and will lock it in the inner position and prevent slide from dropping far enough to complete contact. See figure 10-46. Hold throttle open to prevent release of piston until completion of Steps 4 and 5. Remove drill or wire.

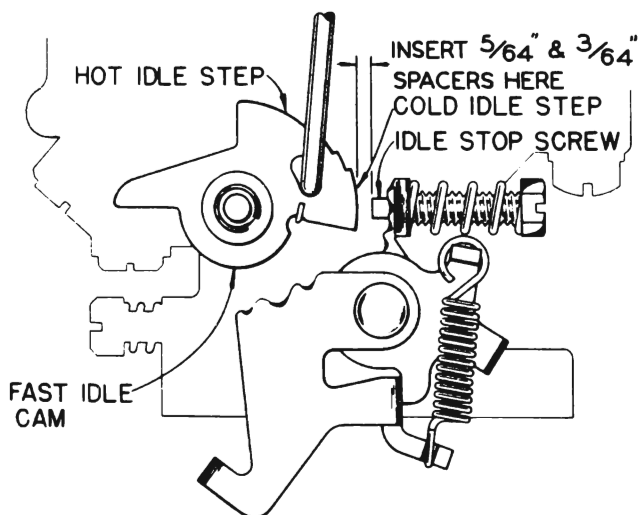

Figure 10-47—Spacer Between Idle Stop Screw and Fast Idle Cam

4. Place $\frac{5}{64}$ " spacer between idle stop screw and fast idle cam while holding fast idle cam in extreme cold idle position. Close throttle so that spacer will hold cam in this position. See figure 10-47. Turn ignition on, hold spacer and open throttle. Engine should *not* crank.

NOTE: A test light with a battery may be used in series with switch instead of turning on ignition.

5. Still holding throttle open, place $\frac{3}{64}$ " spacer between idle stop screw and fast idle cam while holding fast idle cam in extreme cold idle position. Close throttle so that spacer will hold cam in this position (fig. 10-47) and again open throttle with ignition on. Engine *should* crank.

6. If the $\frac{5}{64}$ " spacer causes the engine to crank, bend tang on operating lever downward.

If the $\frac{3}{64}$ " spacer does not cause engine to crank, bend tang on lever upward. In making either adjustment bend tang on operating lever only a slight amount each time until, by re-checking with the above procedure, the specified spacing is obtained.

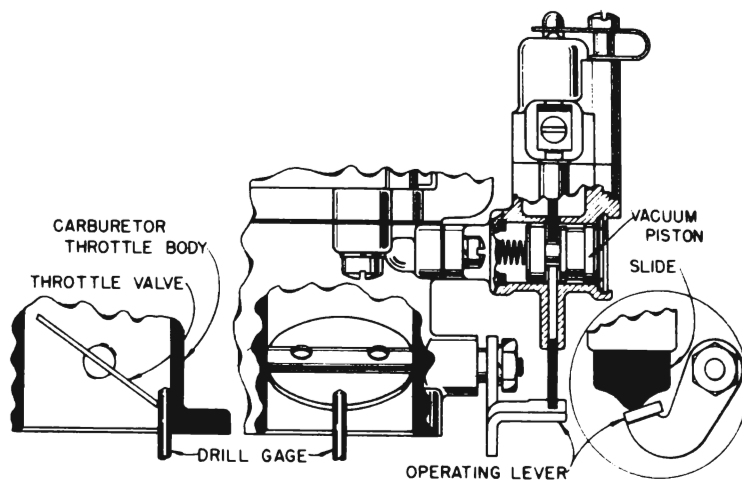

Figure 10-48—Setting Switch Timing with Carburetor Removed

c. Setting Switch Timing with Carburetor Removed from Engine

If the carburetor has been removed from the engine an approximate switch timing setting may be made as follows:

1. On Series 40-50, place a .075" to .085" drill (#45 to #48) between throttle valve and carburetor barrel. On Series 70, use a .090" to .100" drill (#39 to #42). Close throttle to hold drill in position.

2. Bend tang on switch operating lever until it just touches switch slide. See figure 10-48.

3. After carburetor is installed on engine, always recheck switch timing as described in subparagraph *b* above.

d. Cleaning and Lubricating Switch

The accelerator vacuum switch may be removed for cleaning or replacement of parts without removing the carburetor. Disconnect wires and remove two screws which attach switch to the throttle body of carburetor.

The switch may be readily disassembled by referring to figure 10-42. Wash all metal parts in white gasoline and wipe dry. Do not soak bakelite parts in cleaning solution, but wipe with a clean cloth.

Lubrication of switch contacts is unnecessary unless parts have been cleaned or replaced, in which case the inside surface of the terminal cap should be given a *light* coating of Beacon M-285 lubricant which is available in small tubes at authorized Stromberg Carburetor Serv-

ice Stations. If this lubricant is not available petroleum jelly may be used. Lubricant should be applied sparingly by working into a clean cloth and lightly swabbing the inside surface of terminal cap. CAUTION: *Never use ordinary lubricants, as poor switch contact will be obtained in cold weather. Never apply lubricant to slide or piston.*

When switch is reassembled observe the following points:

1. Make certain that the contact guide spring and the vacuum piston spring are installed in their proper positions. The contact guide spring may be identified as the heavier of the two springs. See figure 10-42.

2. Make certain that piston is installed with the end having the deep groove and tapered counterbore nearest the seal.

3. Use care in handling the U-shaped contact spring to avoid altering the dimension of the open end. The open end measures $\frac{9}{16}$ " from outside to outside of the curved ends of spring. See figure 10-42.

4. Make certain that the narrow projection on top of slide is properly entered in the slot in bottom of contact guide.

When switch is reinstalled on carburetor use a new gasket to insure a vacuum-tight seal. Check and set switch timing as described in subparagraph *b* above.

10-34 NEUTRAL SAFETY SWITCH — DYNAFLOW DRIVE CARS

a. Description

Dynaflow Drive cars are provided with a neutral safety switch which prevents operation of the cranking motor except when the transmission is in the Neutral (N) or Park (P) positions. This switch is a safety feature installed for the purpose of preventing car motion when starting the engine.

The neutral safety switch is connected in series with the cranking motor control circuit, in the line between the ignition switch and the accelerator vacuum switch. It is mounted at the lower end of the steering gear column jacket and is operated by the lever at lower end of the transmission control shaft.

It is important that the neutral safety switch be maintained in proper adjustment, as described in subparagraph *b*, below.

b. Checking Neutral Safety Switch Adjustment

When properly adjusted, the neutral safety

switch will allow the cranking motor control circuit to remain closed until the shift control lever is moved out of Neutral (N) toward Park (P) far enough to move outer end of control lever pointer $\frac{5}{32}$ ". If pointer travel from "N" to point where the switch opens the circuit is less than $\frac{1}{8}$ ", failure to obtain cranking in neutral may result. If pointer travel is more than $\frac{3}{16}$ ", cranking may be obtained with shift lever in Drive (D) position, resulting in car movement during cranking.

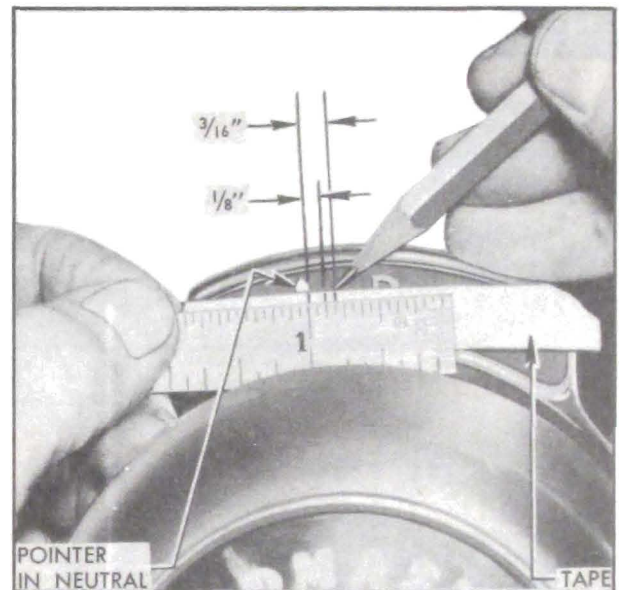

Figure 10-49—Marking Switch Cut-in Limits on Shift Control Window

Use the following procedure to determine whether neutral safety switch operates within the required limits.

1. Ground the primary terminal of distributor with jumper wire so that engine can be cranked without firing.

2. Firmly engage "step-on" parking brake and place transmission shift control lever in Neutral (N), making certain that stop is in shift detent.

3. Place a narrow strip of masking tape on shift control window so that tip of control lever pointer is visible. Make two marks on masking tape at $\frac{1}{8}$ " and $\frac{3}{16}$ " from right edge of pointer. See figure 10-49.

4. Move shift control lever to Drive (D) position, turn ignition on and depress accelerator pedal.

5. Slowly move shift control lever pointer from "D" toward "N", and note position of right edge of pointer at instant that cranking motor starts to operate. This should be between the $\frac{1}{8}$ " and $\frac{3}{16}$ " marks on masking tape. See figure 10-50.

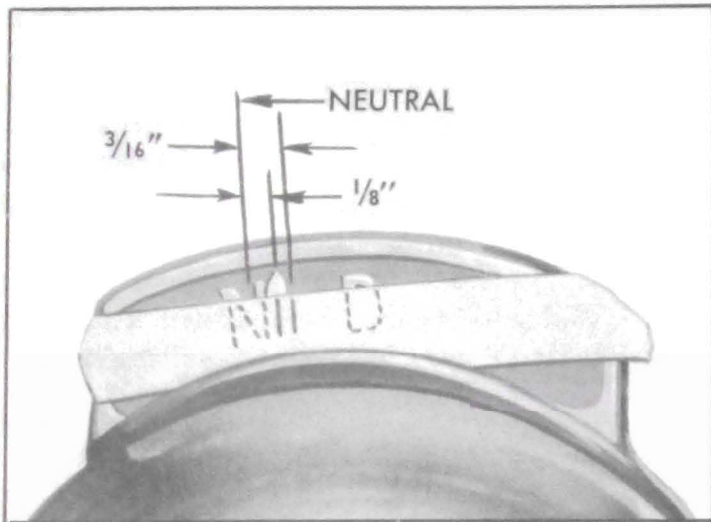

Figure 10-50—Control Lever Pointer at Switch Cut-in Limits

6. If switch cuts in when pointer is $\frac{1}{8}$ " to $\frac{3}{16}$ " from "N" position remove jumper wire from distributor; otherwise, adjust switch as described in subparagraph *c* below.

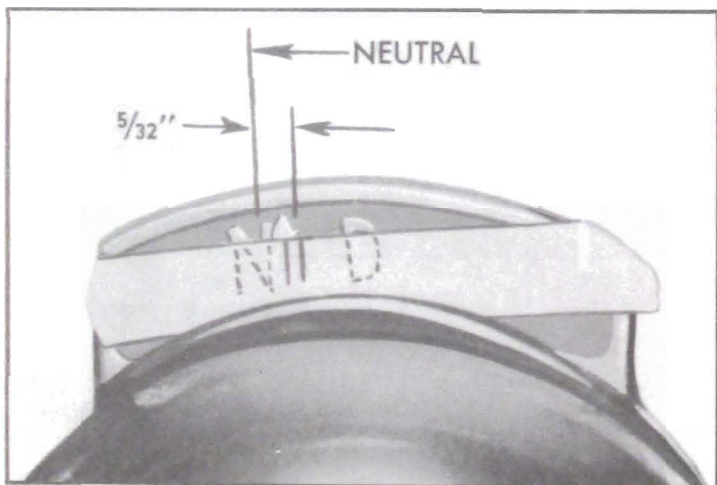

Figure 10-51—Pointer Position for Adjusting Neutral Safety Switch

c. Adjusting Neutral Safety Switch

1. Continue from step 3 of subparagraph *b* above.

(2) Have a helper hold shift control lever so that *right* edge of pointer is exactly midway between the marks on masking tape ($\frac{5}{32}$ " out of "N" position). See figure 10-51. Maintain lever in this position during the following adjustment of neutral safety switch.

3. Loosen the two mounting bolts which hold the safety switch at foot of steering gear column jacket and raise switch up as far as it will go. See figure 10-52.

4. Have the helper turn on ignition switch and depress accelerator pedal to close vacuum switch.

5. Gently tap the neutral safety switch downward until the cranking motor just starts

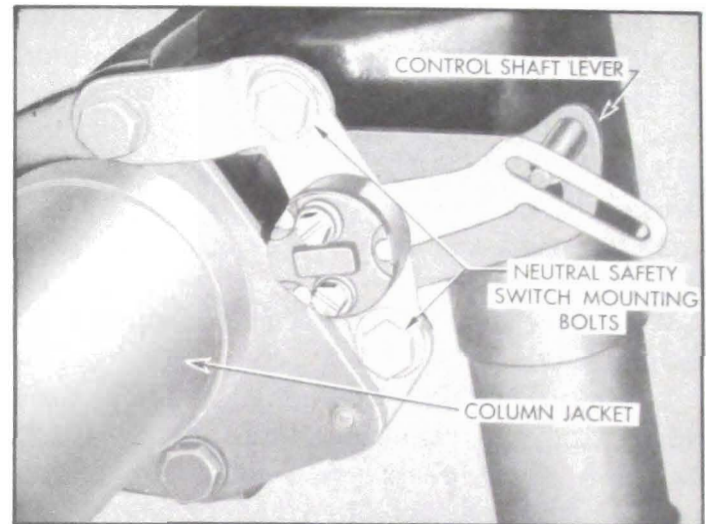

Figure 10-52—Neutral Safety Switch Mounting

to operate. Make certain that control lever pointer has not moved from the $\frac{5}{32}$ " setting made in step 2. Turn off ignition switch and release accelerator pedal.

6. Tighten switch mounting bolts being careful not to allow switch to move.

7. Recheck switch adjustment as in subparagraph *b* above.

8. Remove jumper wire from distributor.

10-35 CRANKING MOTOR ASSEMBLY

The cranking motor assembly consists of a motor, drive assembly, shift lever, solenoid switch and relay. See figure 10-53. It is mounted on the flywheel upper housing on the right side of engine.

a. Cranking Motor

The motor used on *Series 40-50* is of the induced pole type having four brushes and four poles but only two field coils. The motor used on *Series 70* is a four pole motor having four brushes and four field coils. Both motors are series-wound.

The armature shaft is supported at both ends in graphite bronze bushings pressed into the commutator end frame and the drive housing. In the *Series 70* motor, the shaft is also supported by a graphite bronze bushed center bearing plate which is mounted on the inner end of the drive housing. None of these bearings require lubrication. See figure 10-53.

The four brushes are supported by brush holders mounted on the commutator end frame. Two opposing brushes are grounded to the frame and the other two opposing brushes are connected to the field coils. The field coils are held in place by the pole shoes which are at-

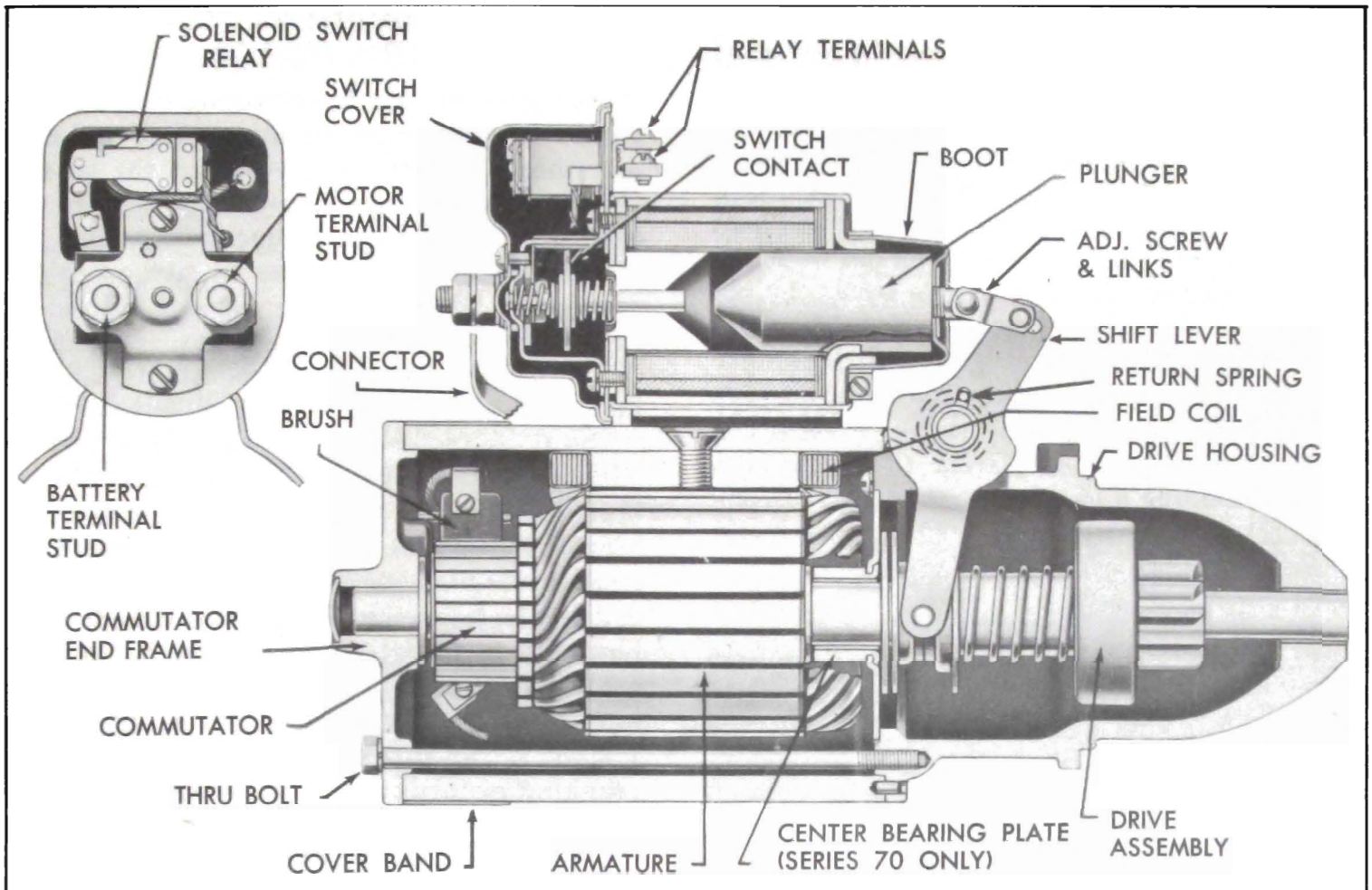

Figure 10-53—Cranking Motor, Sectional View—Series 70

tached to the field frame by large screws. The field coils are connected to an insulated terminal stud on the field frame, through which current is supplied to the motor.

b. Cranking Motor Drive Assembly and Shift Lever

The drive assembly is mounted on the motor armature shaft and keyed to it by splines so that it can be moved endwise on the shaft by the solenoid operated shift lever. It transmits cranking torque to the flywheel ring gear, but allows the drive pinion to rotate freely with reference to the armature shaft when the engine begins to operate, thus preventing the armature from being driven at excessive speed by the engine.

The drive assembly consists of a pinion-and-collar, overrunning clutch, spring, and shift collar. The overrunning clutch consists of a shell and sleeve assembly, which is internally splined to the armature shaft. The pinion collar fits within the clutch shell. Four tapered notches cut in the clutch shell house four hardened steel rolls in position so that they can bear against the pinion collar. A spring and plunger presses each roll toward the small end of the

notches and into contact with the pinion collar. See figure 10-54.

When the clutch shell is rotated by the armature shaft, the rolls jam between the shell and pinion collar and force the pinion to rotate with the shell. When the pinion is rotated by the flywheel ring gear, after the engine starts, the rolls are rotated out of the small end of the notches so that the pinion collar and clutch shell are no longer locked together, consequently the high speed of the pinion is not transmitted to the armature shaft.

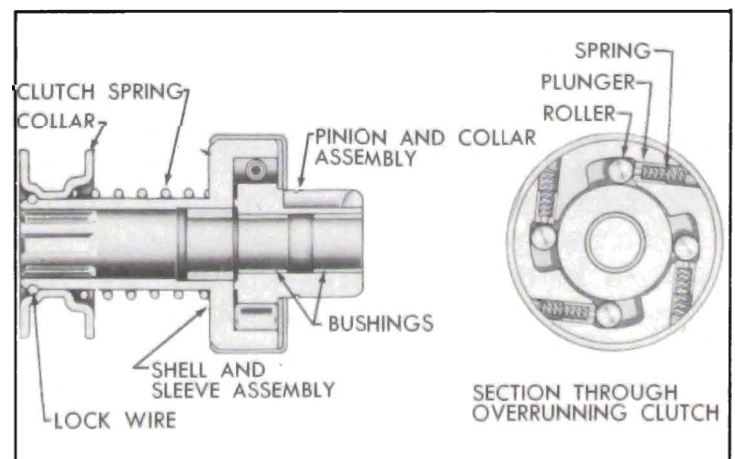

Figure 10-54—Cranking Motor Drive Assembly, Sectional Views

The drive assembly pinion is moved into engagement with flywheel ring gear by action of the solenoid upon the shift lever, which engages the shift collar of drive assembly. The shift collar moves the drive assembly by pushing on the clutch spring, which serves as a cushion in case the pinion and gear teeth butt instead of meshing. The drive pinion is pulled out of engagement, after engine starts, by action of the shift lever return spring. The shift lever is connected to the solenoid switch plunger by a link and adjusting screw. See figure 10-53.

The drive pinion on all series has 9 teeth. The flywheel ring gear on *Series 40-50* has 146 teeth, providing a gear ratio of 16.22 to 1. The flywheel ring gear on *Series 70* has 156 teeth, providing a gear ratio of 17.33 to 1.

c. Solenoid Switch and Relay

The solenoid switch not only closes the circuit between the battery and the cranking motor to produce cranking action, but it also operates the shift lever to move the drive pinion into engagement with the flywheel ring gear.

The solenoid section of the switch has a plunger and two windings, the "pull-in" winding and the "hold-in" winding. Together, they provide sufficient magnetic attraction to pull the solenoid plunger into the solenoid. The plunger actuates the shift lever and drive assembly and it also closes the solenoid switch contacts by pressing against a push rod upon which a contact disk is mounted between two coil springs. One spring serves as a cushion to insure firm contact of the disk with two stationary contacts. The other spring pushes the disk away from the stationary contacts to break the circuit when the solenoid is demagnetized after the engine starts. One stationary contact is connected to the battery positive cable and the other is connected to the motor windings through a connector or bus bar. See figure 10-53.

The solenoid switch relay is an electrical switch which closes the circuit between the battery and the solenoid windings when cranking action is desired, and opens the circuit when the engine starts running. The relay has one winding surrounding a core which, when magnetized by current flowing through the winding, attracts a flat steel armature. The armature has a contact point which makes contact with a stationary point to close the circuit.

Operation of the solenoid switch and relay, as well as the entire cranking system, is described in paragraph 10-31.

10-36 PERIODIC INSPECTION OF CRANKING MOTOR

As a general rule, the cranking motor should be tested and inspected every 5000 miles to determine its condition; however, the type of service in which some cranking motors are used may make more frequent inspection advisable. Frequent starts, as in city operation, excessively long cranking periods caused by hard-starting engine conditions, excessively dirty or moist operating conditions, all will make more frequent inspection advisable.

Cranking motor action is indicative, to some extent, of the cranking motor condition. A cranking motor that responds readily and cranks the engine at normal speed when the control circuit is closed is usually in good condition. The following inspection should be made, however, to insure continued satisfactory operation.

1. Remove commutator cover band and inspect it for thrown solder which results if cranking motor is subjected to excessively long cranking periods, causing it to overheat. Since thrown solder results in loose or broken connections between armature windings and commutator riser bars, which usually causes burned commutator bars, the motor must be removed for repairs (par. 10-41).

2. Inspect commutator; if it is rough, out of round, or has high mica between the bars it will require turning down and undercutting of the mica. The motor must be removed for this work.

3. Check condition of brushes; make sure they are not binding and that they are resting on the commutator with sufficient tension to give good, firm contact. Brush leads and screws must be tight. If the brushes are worn down to one-half their original length, compared with new brushes, the motor must be removed for installation of new brushes.

4. If commutator and brushes are in good condition but dirty, they may be cleaned without removal of motor. Clean off any grease with a cloth soaked with carbon tetrachloride or other non-inflammable solvent. While motor is operating, quickly polish commutator with a brush seating stone or with a strip of 2/0 sandpaper placed over a wooden block having a smooth square end. *Do not use emery cloth.* To operate cranking motor, turn ignition switch off and connect a jumper wire between battery terminal of solenoid switch and the terminal of

solenoid relay to which the wire with black parallel tracer is connected. **CAUTION:** *Do not operate cranking motor more than 30 seconds at a time without pausing to allow motor to cool for at least two minutes; otherwise, overheating and damage to motor may result.* After cleaning commutator, blow out all dust from cranking motor.

5. Check motor and solenoid switch attaching bolts to make sure these units are solidly mounted. Inspect and manually check all wiring connections at solenoid switch, solenoid relay, generator regulator, generator, accelerator vacuum switch, ignition switch, No. 1 terminal of headlamp lighting switch, charge indicator, and neutral safety switch (Dynaflow Drive cars only). Make sure that all these connections in the cranking motor and control circuits are clean and tight. It is advisable to test the cranking circuit to make certain that excessive resistance does not exist. See paragraph 10-37.

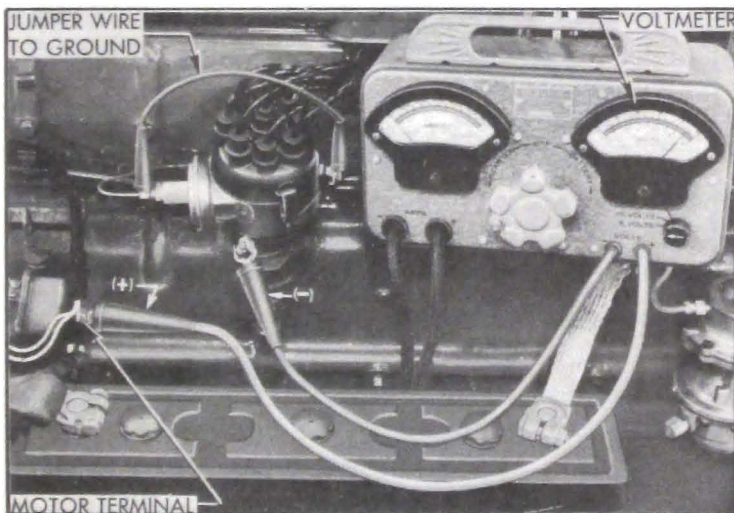

Figure 10-55—Cranking Voltage Test Connections

10-37 VOLTAGE TEST OF CRANKING MOTOR AND SOLENOID SWITCH

The voltage across the cranking motor and switch while cranking the engine gives a good indication of any excessive resistance. **NOTE:** *Engine must be at normal operating temperature when test is made.*

1. Inspect battery and cables (par. 10-17) to make certain that battery has ample capacity for cranking and ignition.
2. Connect jumper wire to primary terminal of distributor and to ground on engine, so that engine can be cranked without firing.
3. Connect voltmeter positive (+) lead to the motor terminal on solenoid switch; connect

voltmeter negative (–) lead to ground on engine. See figure 10-55.

4. Turn ignition switch on, crank engine and take voltmeter reading as quickly as possible. If cranking motor turns engine at normal cranking speed with voltmeter reading 4.5 or more volts, the motor and switch are satisfactory. If cranking speed is below normal and voltmeter reading is 4.5 or greater, the cranking motor is defective.

5. If cranking motor turns engine at low rate of speed with voltmeter reading less than 4.5 volts, test solenoid switch contacts as follows.

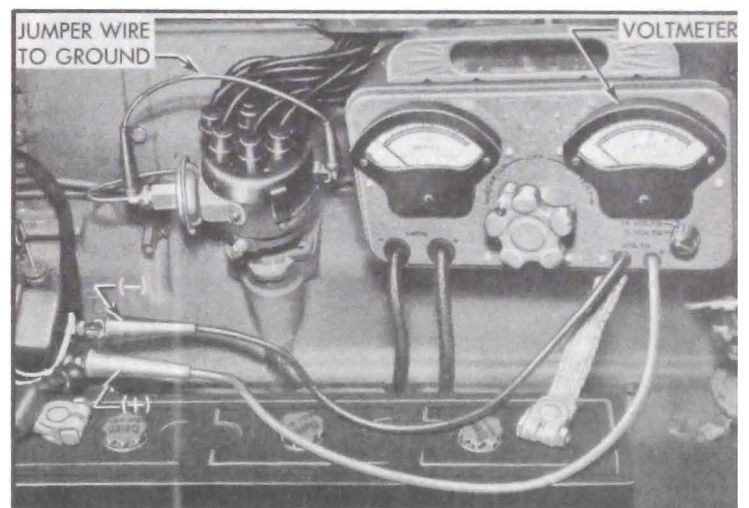

Figure 10-56—Solenoid Switch Contact Test Connections

6. Connect voltmeter negative (–) lead to the motor terminal of solenoid switch, and connect positive (+) lead to battery terminal of switch. Turn voltmeter switch to low voltage scale. See figure 10-56.

7. Turn ignition switch on, crank engine, and take voltmeter reading as quickly as possible. Voltmeter will read not more than $\frac{1}{10}$ volt if switch contacts are satisfactory. If voltmeter reads more than $\frac{1}{10}$ volt, switch should be repaired or replaced.

10-38 TEST AND ADJUSTMENT OF SOLENOID SWITCH RELAY

When the solenoid switch relay is operating properly, the contact points will close at 1.2 to 1.8 volts, and will open at not less than .6 volts, when tested with relay *cold* (at room temperature). The relay must cut in at this low voltage so that it will operate during cold weather with a low battery.

The solenoid switch relay should not be tampered with unless the proper test equipment is

available. Test equipment consists of an accurate low reading voltmeter and a variable rheostat of at least 10 ohm having a capacity for 2 amperes.

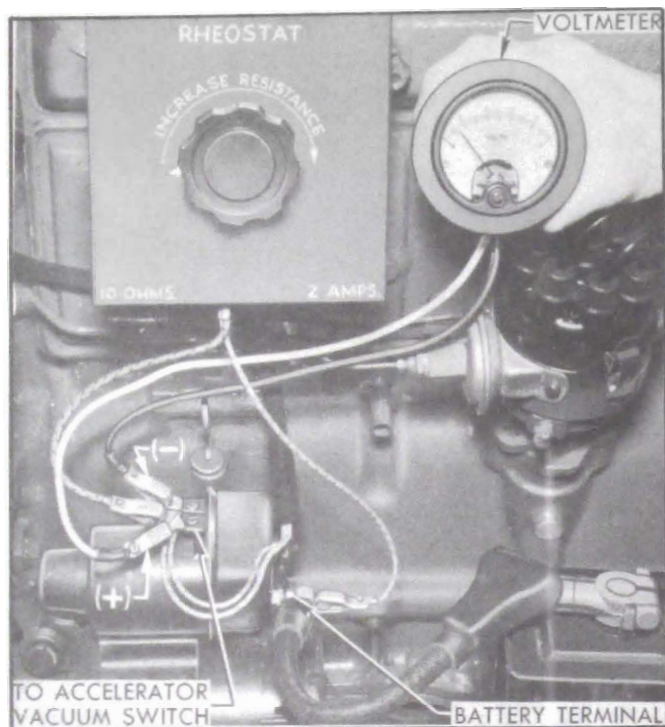

Figure 10-57—Connections for Testing Cut-in and Cut-out Voltages of Solenoid Switch Relay

a. Testing Solenoid Switch Relay Cut-in and Cut-out Voltages

Solenoid switch relay cut-in and cut-out voltages may be determined with cranking motor installed and without removing switch cover as follows:

1. Make sure that ignition switch is turned off.
2. Set rheostat to provide full resistance. Connect one lead of rheostat to battery terminal on solenoid switch, and connect other lead to terminal on solenoid switch relay which has white wire with black parallel tracers connected to it. This wire is connected to the accelerator vacuum switch. See figure 10-57.
3. Connect voltmeter leads to both relay terminals.
4. Turn rheostat to slowly decrease resistance until engine just starts to crank and note voltmeter reading at this cut-in point. Reading should be between 1.2 and 1.8 volts.
5. Quickly turn rheostat until all resistance is cut out and full voltage is applied to the relay to fully saturate the magnet core.
6. As quickly as possible, increase resistance until motor discontinues cranking, and note voltmeter reading at the cut-out point. This should be not less than .6 volt.

7. If solenoid relay does not operate within the voltage limits specified, it must be adjusted (subpar. *b*, below).

b. Solenoid Switch Relay Adjustments

When the solenoid switch relay does not operate within the voltage limits specified in subparagraph *a* above, five checks and adjustments must be made in the following order: Air gap, contact point opening, closing voltage, sealing voltage and opening voltage. This work cannot be properly done with cranking motor installed on engine.

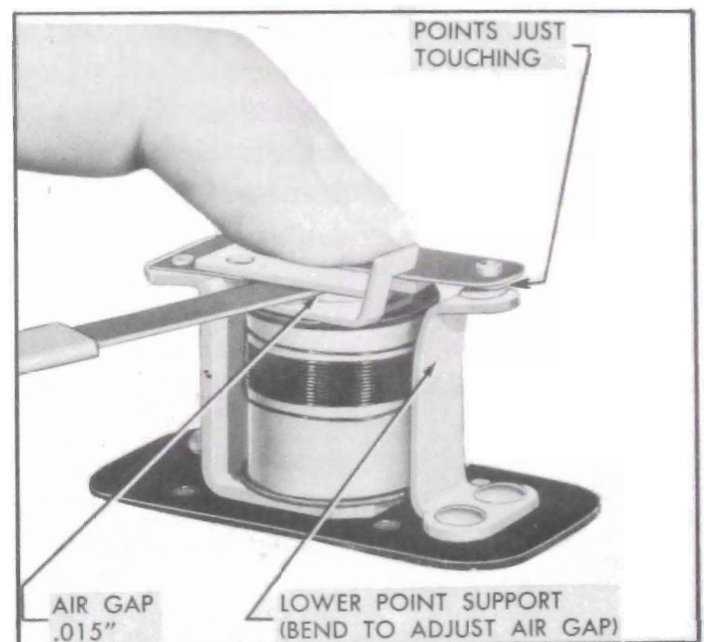

Figure 10-58—Relay Air Gap Adjustment

1. Remove cranking motor from engine and remove switch cover.
2. Push relay armature down until contact points just touch, then check air gap between armature and end of core, using .015" feeler gauge. Air gap should be not less than .015". Adjust gap to .015, if necessary, by bending the lower point support. See figure 10-58.
3. With armature free, check contact point opening, using .025" feeler gauge. Adjust point opening to .025", if necessary, by bending the upper armature stop. See figure 10-59.
4. Connect a 6-volt battery and the 10 ohm rheostat in series between the relay terminals. Connect the low reading voltmeter between the relay terminals.
5. Slowly adjust rheostat to increase voltage until contact points close and note voltage. Closing voltage should be 1.2 to 1.8 volts. If not within these limits, bend armature spring post down to increase spring tension and closing

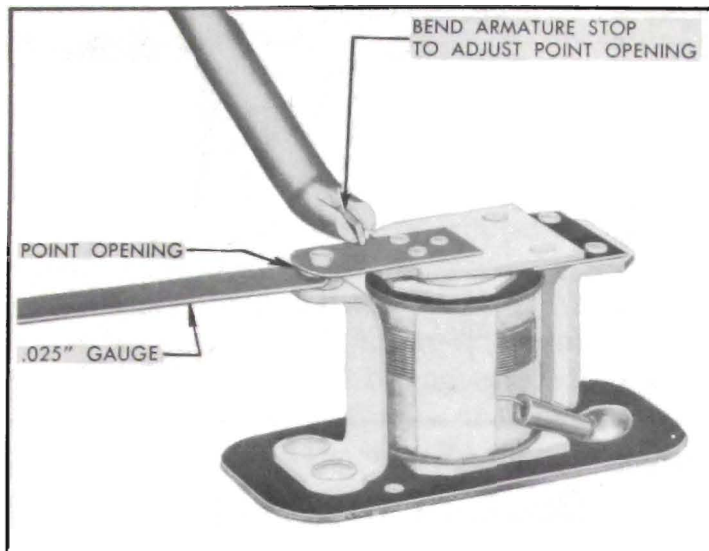

Figure 10-59—Relay Contact Point Adjustment

voltage, or bend up to decrease voltage. See figure 10-60. Recheck closing voltage after each adjustment.

6. Check sealing voltage by continuing to raise voltage slowly after points close until armature seals to core. (This is usually accompanied by an audible click.). Sealing voltage should be not more than 3 volts.

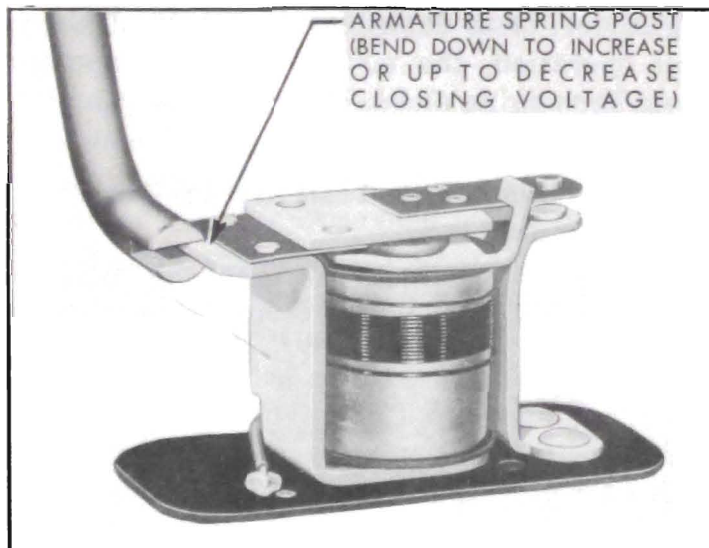

Figure 10-60—Relay Closing Voltage Adjustment

7. Cut out all resistance to completely saturate coil, then slowly reduce voltage until contact points open, and note voltage. Opening voltage should be not less than .6 volt.

8. Sealing and opening voltages can be adjusted by varying the adjustment of air gap or closing voltage within specification limits. Closing voltage should be rechecked after adjustments of sealing or opening voltage.

9. Install switch cover and gasket and install cranking motor on engine.

10-39 SOLENOID SWITCH TEST AND REPAIRS — CRANKING MOTOR ON BENCH

a. Testing Solenoid Switch Windings

When the cranking motor is removed from engine, the solenoid switch windings can be tested with switch either on or off the cranking motor, if the required test instruments are available. Two tests must be made to determine:

- (1) Current draw of both windings in parallel;
- (2) Current draw of hold-in winding alone.

1. Remove switch-to-motor connector, and remove switch cover and gasket.

2. Connect 6-volt battery, a variable resistance, and an ammeter of 75 amperes capacity in series with base of solenoid and the terminal on relay to which solenoid windings are soldered. Connect voltmeter between solenoid base and the solenoid winding leads at relay terminal. Ground the switch motor terminal to solenoid base with a jumper wire.

3. Slowly adjust resistance until voltmeter reads 5 volts and note current draw on ammeter. Current draw of both windings in parallel should be 65 to 71 amperes at 5 volts. **CAUTION:** Do not close the solenoid relay contact points when making this test since this would cause a direct short when the solenoid switch operated.

4. Remove jumper wire and readjust resistance until voltmeter reads 5 volts. The current draw of the hold-in winding alone should be 12 to 14 amperes at 5 volts.

5. If the solenoid windings do not test within the specifications given, the solenoid switch assembly requires replacement.

b. Replacement of Parts

The solenoid switch may be disassembled by removal of parts as shown from right to left in figure 10-61.

For replacement of the relay assembly it is necessary to unsolder the solenoid winding leads. When resoldering leads use only rosin flux—never use acid flux when soldering electrical connections.

It is not necessary to unsolder the solenoid winding leads in order to replace the switch contact disk or terminal studs.

When assembling switch, note that two fiber washers, a plain washer, and a lock washer go on each terminal stud before installing the first nut.

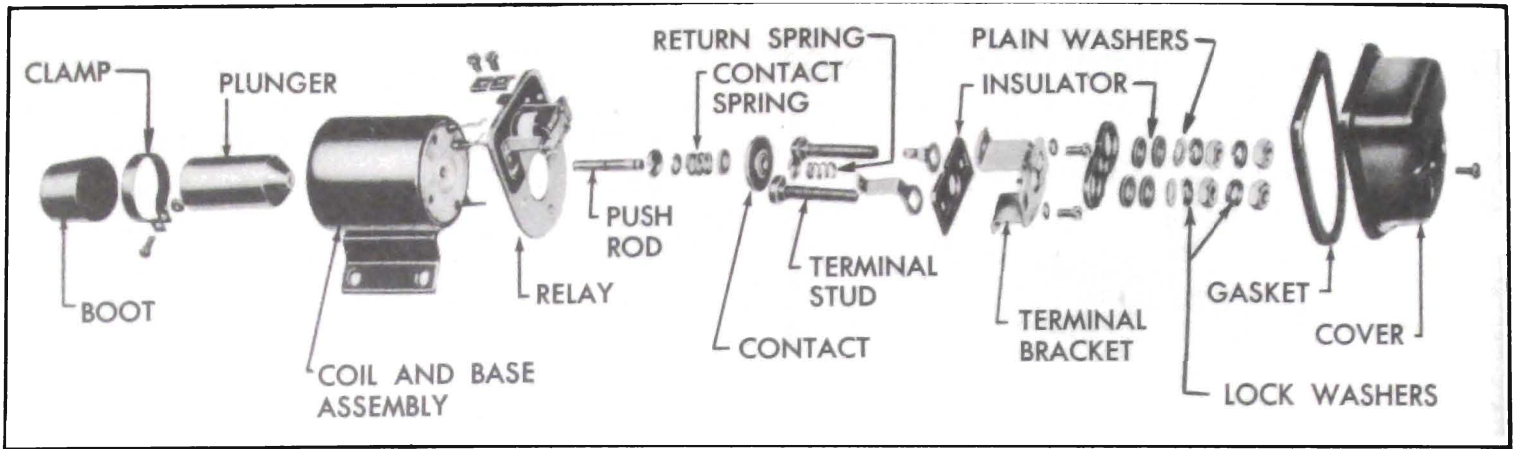

Figure 10-61—Solenoid Switch Disassembled

c. Installing Solenoid Switch and Adjusting Drive Pinion Travel

Whenever the solenoid switch is removed and reinstalled on cranking motor it is necessary to adjust the drive pinion travel so that there will be $\frac{3}{16}$ " clearance between the end of pinion and the drive housing when pinion is in cranking position.

1. Remove the connector between solenoid switch and cranking motor terminals so that motor will not operate.

5. If adjustment is required, remove pin which connects adjusting screw links to the shift lever and turn adjusting screw as required to provide $\frac{3}{16}$ " clearance at end of pinion when link pin is installed.

6. Apply several drops of 10-W oil to armature shaft splines and shift lever pivot stud, but do not oil solenoid plunger as this would cause plunger to gum and stick in cold weather.

10-40 BENCH TEST OF CRANKING MOTOR

To obtain full performance data on a cranking motor, or to determine the cause of abnormal operation, the motor should be removed from the engine and be submitted to a no-load and a torque test.

a. Cranking Motor Tests and Equipment Required

In the no-load test, the cranking motor is connected in series with a 6-volt battery and an

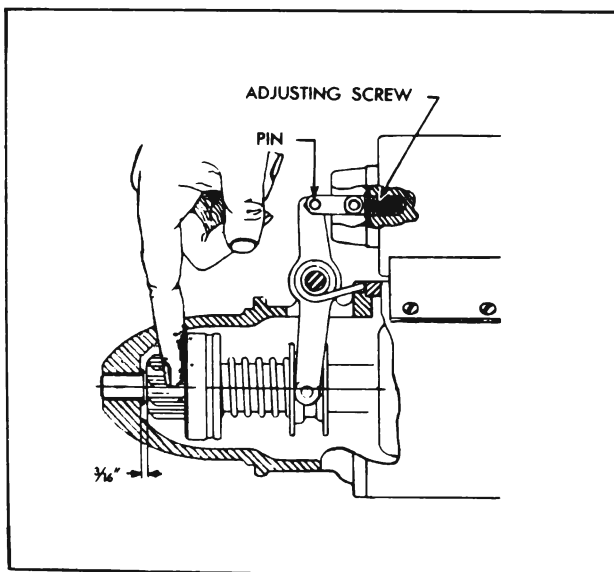

Figure 10-62—Checking Pinion Travel

2. Remove solenoid switch cover and connect around relay points with a jumper wire.

3. Connect a 6-volt battery to solenoid switch terminals, and push solenoid plunger into solenoid by hand. Once in, battery current will hold it in place so that the drive pinion clearance can be checked and adjusted.

4. Press finger lightly against outer side of drive assembly shell to take out all lash in shift linkage, then measure clearance between end of pinion and machined surface on drive housing. Clearance should be $\frac{3}{16}$ ". See figure 10-62.

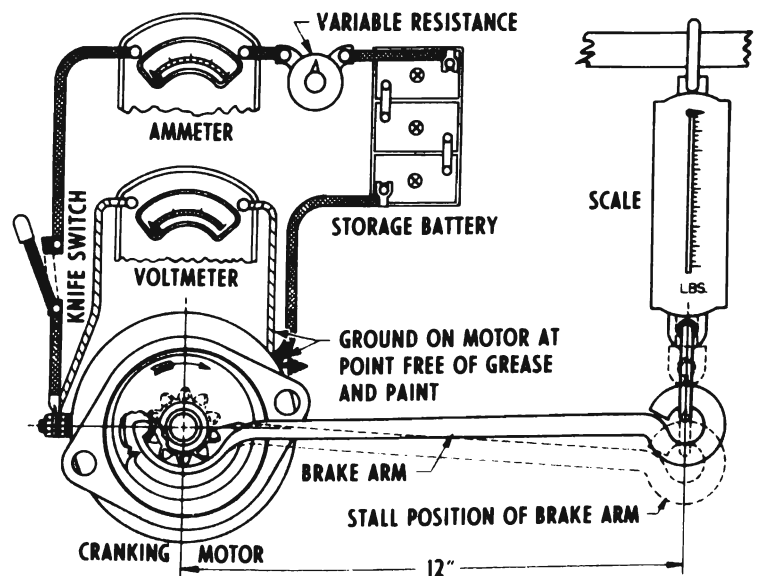

Figure 10-63—Diagrammatic Layout for Cranking Motor Torque Test

ammeter capable of reading several hundred amperes. A voltmeter is connected between the insulated motor terminal and ground on the frame at a point free of grease and paint. A speed indicator should also be used to measure the armature revolutions per minute.

The torque test requires equipment such as shown in figure 10-63. The cranking motor is securely mounted and the brake arm hooked to the drive pinion. With a one-foot brake arm as shown, the torque will be indicated directly on the scale in pounds feet when the specified voltage is applied to the motor. Specified voltage is applied through the use of a high-current-carrying variable resistance.

An armature growler and a test lamp with pointed prods on the leads are also required for checking internal condition of armature and the field windings.

b. Interpreting Results of Tests

Test specifications are given under Electrical Specifications (par. 10-3). The specifications are given at low voltages so that torque and ammeter readings obtained will be within the range of testing equipment available in the field.

1. *Rated torque, current draw and no-load speed* indicates normal condition of cranking motor.

2. *Low free speed and high current draw with low developed torque* may result from:

(a) Tight, dirty, or worn bearings, bent armature shaft or loose field pole screws which would allow the armature to drag.

(b) Shorted armature. Check armature further on growler (par. 10-28, b).

(c) A grounded armature or field. Check by raising the grounded brushes and insulating them from the commutator with cardboard, and then checking with a test lamp between the insulated terminal and the frame. If lamp lights, raise other brushes from commutator and check fields and commutator separately to determine whether it is the fields or armature that is grounded.

3. *Failure to operate with high current draw may result from:*

(a) A direct ground in the terminal or fields.

(b) Frozen shaft bearings which prevent the armature from turning.

4. *Failure to operate with no current draw may result from:*

(a) Open field circuit. Inspect internal connections and trace circuit with test lamp.

(b) Open armature coils. Inspect the commutator for badly burned bars.

(c) Broken or weakened brush springs, worn brushes, high mica on the commutator, or other causes which would prevent good contact between the brushes and commutator. Any of these conditions will cause burned commutator bars.

5. *Low no-load speed with low torque and low current draw* indicates:

(a) An open field winding. Raise and insulate ungrounded brushes from commutator and check field with test lamp.

(b) High internal resistance due to poor connections, defective leads, dirty commutator and causes listed under item 4 (c). Running free speed, an open armature will show excessive arcing at the commutator bar which is open.

6. *High free speed with low developed torque and high current draw* indicates shorted fields. There is no easy way to detect shorted fields, since the field resistance is already low. If shorted fields are suspected, replace the fields and check for improvement in performance.

10-41 CRANKING MOTOR REPAIRS — ON BENCH

a. Disassembly, Cleaning, and Inspection

When it is necessary to disassemble cranking motor for any reason, make a complete clean up and inspection to make sure all parts are in satisfactory condition. See figure 10-64 for identification of parts.

1. Disconnect plunger from shift lever by removing adjusting screw link pin. Remove solenoid switch.

2. Remove commutator cover band and disconnect brush leads from the field leads.

3. Unscrew the through bolts and separate the commutator end frame, field frame, and drive housing.

4. On *Series 70* cranking motor, remove the center bearing plate and thrust washer from drive housing.

5. Remove shift lever and spring, then remove drive assembly from drive housing.

6. If field coils are to be removed from field frame, a pole shoe spreader (KMO 579) and pole shoe screwdriver should be used to avoid distortion of frame. See figure 10-65.

7. Clean all parts by wiping with clean cloths. The armature, field coils, and drive as-

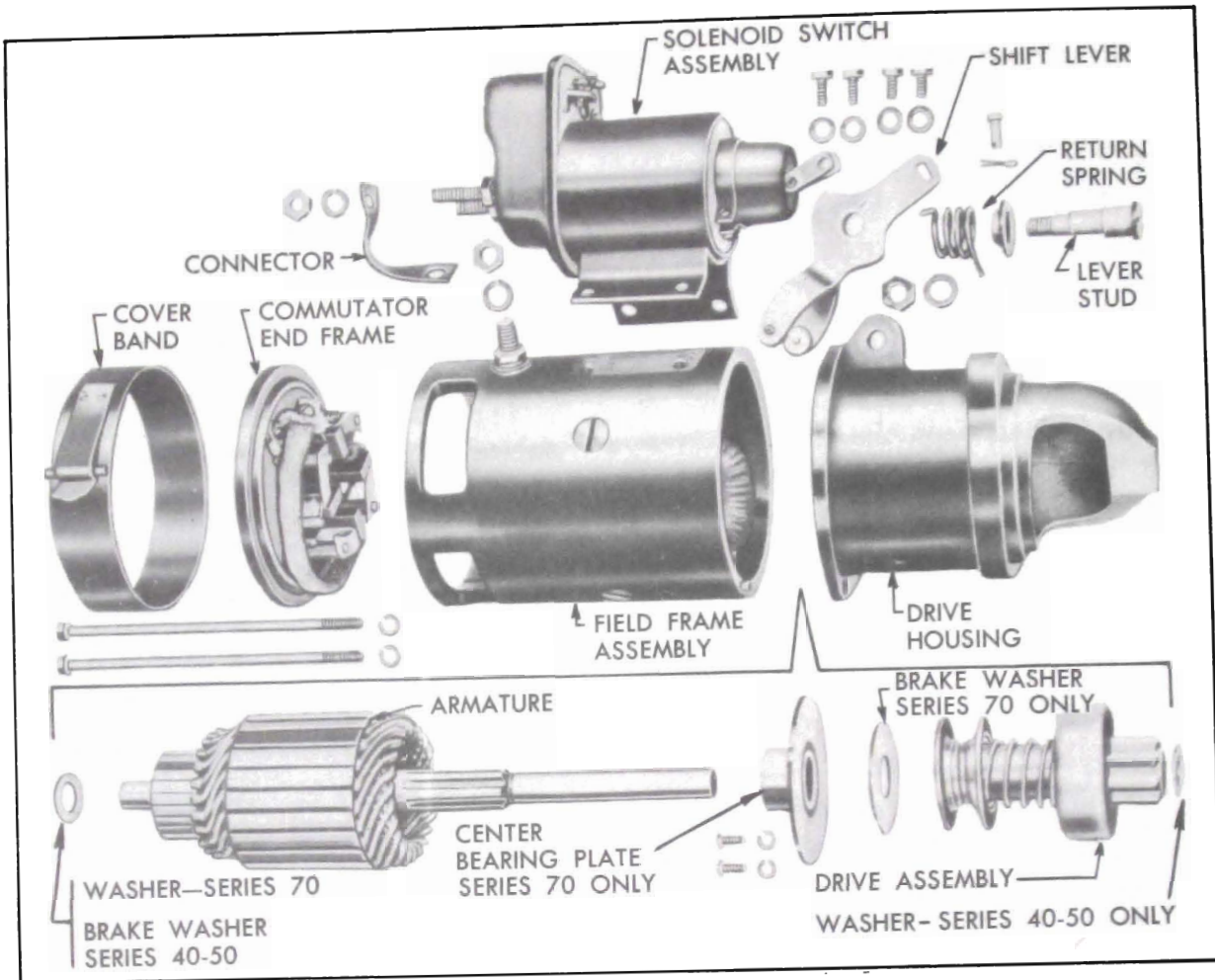

Figure 10-64—Cranking Motor Disassembled

sembly must not be cleaned by any degreasing or high temperature method. This might damage insulation so that a short or ground would subsequently develop, and will remove lubricant originally packed in the overrunning clutch so that clutch would soon be ruined.

8. Carefully inspect all parts for wear or damage and make necessary repairs or replace unserviceable parts. If brush springs are distorted or show evidence of overheating, replace them. Any soldering must be done with rosin flux; *never use acid flux on electrical connections.*

9. Test armature and make necessary repairs or turn commutator if required, following the same procedure as specified for generator armature in paragraph. 10-28.

b. Assembly of Cranking Motor

Assemble cranking motor by reversing disassembly procedure. If field coils were removed, use pole shoe spreader (KMO 579) and pole shoe screwdriver to install them, to avoid distorting field frame and to insure proper tightening of pole shoe screws. See figure 10-65.

Before installation of solenoid switch check the shift lever spring for proper tension. A

weak spring may cause sluggish disengagement of drive clutch pinion in cold weather, particularly if the shaft is gummed up. With spring scale connected to hole in upper end of shift lever, the pull at start of travel should be 9 to 12 pounds and at end of travel should be 28 to 35 pounds.

When solenoid switch plunger is connected to

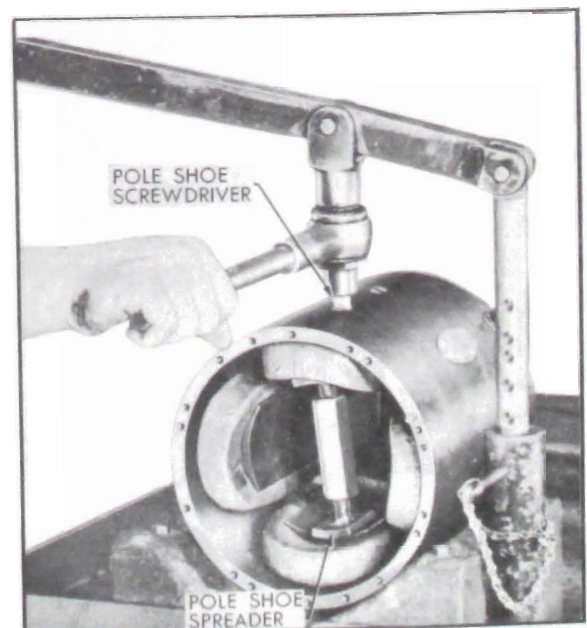

Figure 10-65—Using Pole Shoe Spreader and Screwdriver

shift lever, adjust drive pinion travel to provide $\frac{3}{16}$ " clearance in cranking position as described in paragraph 10-39 (c).

If new brushes were installed, or old brushes were removed from holders, loosen brush attaching screws to allow brushes to seat squarely against commutator, then firmly tighten screws. Attach spring scale at each brush and check

the pull required to just lift brush off commutator. Brush spring tension should be 24 to 28 ounces. If spring tension is excessive, pull brush holder out to limit of travel several times to give a slight bend to spring. If spring tension is too light, replace brush spring. Make sure that brush holders do not bind on the support pins.