

SECTION 4-B

SYNCHROMESH TRANSMISSION AND UNIVERSAL JOINT

CONTENTS OF SECTION 4-B

Paragraph	Subject	Page	Paragraph	Subject	Page
4-7	S-M Transmission and Universal Joint Specifications	4-9	4-11	Adjustment of Shift Controls—Replacement of Parts	4-17
4-8	Description of S-M Transmission and Universal Joint	4-10	4-12	Adjustment of Torque Ball	4-17
4-9	S-M Transmission Shift Control Mechanism	4-13	4-13	Removal and Installation of S-M Transmission	4-19
4-10	S-M Transmission Trouble Diagnosis	4-15	4-14	Disassembly, Inspection and Assembly of S-M Transmission	4-21

SERVICE BULLETIN REFERENCE

Bulletin No.	Page No.	SUBJECT

4-7 S-M TRANSMISSION AND UNIVERSAL JOINT SPECIFICATIONS

a. Tightening Specifications

Part	Location	Thread Size	Torque Ft.Lbs.
Bolt	Outer Selector Lever	1/4-20	7-10
Nut	Lower Shift Rod Adjust Lock	3/8-24	20-25
Nut	Shift Idler Lever Pin	3/8-24	30-35
Bolt	Shift Lever to Selector Shaft	3/8-24	15-20
Bolt	Trans. Cover to Case	3/8-16	15-20
Screw	Transmission Breather	7/16-20	10-15
Plug	Oil Level and Oil Drain	1/2 Pipe	35-40
Bolt	Trans. Case to Flywheel Housing	1/2-13	55-60
Bolt	Rear Bearing Retainer to Case	7/16-14	40-45
Bolt	Torque Ball to Rear Bearing Retainer	3/8-16	30-35
Bolt	U-Joint to Main Shaft	3/8-24	40-45
Sleeve	Speedometer Driven Gear	15/16-18	45-50
Nut	Trans. Mounting to Trans. Support	3/8-24	30-35
Bolt	Trans. Support to Frame	3/8-24	20-25

b. S-M Transmission Specifications

Mounting	Unit with Engine
Oil Capacity, Pints	1 3/4
Type of Gearing	All Helical
Transmission Ratio—	
In Third	Direct
In Second	1.66 to 1
In First	2.67 to 1
In Reverse	3.02 to 1
Main Drive Gear in Pilot Bearing	.0001" L—.0011" L
Main Drive Gear to Clutch Hub Backlash	.0005"—.0035"

Bearing on Main Drive Gear	.0003" T—.0007" L
Main Drive Gear Bearing in Case	.0002" T—.001" L
Reverse Idler Gear on Shaft	.0002" L—.0042" L
2nd and 3rd Sliding Sleeve on Main Shaft—	
Diameter	.001" L—.003" L
Backlash	Selective .001" L—.003" L
2nd Speed Gear on Main Shaft	.001" L—.0026" L
1st and Rev. Sliding Gear on Sliding Sleeve, Backlash	Selective .003" L
Shifter Yoke Shafts in Case	.003" T—.006" L
Trans. R. Bearing in Case	.0011" T—.0005" L
Trans. R. Bearing on Main Shaft	.0007" T—.0002" L
Counter Gear on Shaft	.0005" L—.0024" L
Counter Gear End Clearance	.0176" L—.0296" L

NOTE: Where dimensions and limits for fit of parts are given in these specifications they apply to new parts only. Where limits are given, "T" means tight and "L" means loose.

c. Universal Joint and Torque Ball

Lubrication	From Transmission
Transmission R. Bearing Retainer Pilot	.000"—.003" L
U-Joint Bearings, Number and Type	4 Hardened Steel Bushings
Diameter of Spider Pins	.684"—.685"
Spider Pins in Bushings	.002" L—.004" L
Rear Yoke on Propeller Shaft, Backlash	.0005"—.0045"
Rear Yoke in Torque Ball Bushing	.004" L—.006" L
Torque Ball Diameter	4 3/4"
Torque Ball Adjustment Drag with 5 3/8" Leverage	10-35 lbs.

d. Speedometer Gears

Speedometer Worm on Main Shaft.....	.0009" T—.0029" L
Teeth on Worm (Driving Gear).....	7
Teeth on Driven Gear, with	
3.6 to 1 Axle Ratio.....	18
3.9 to 1 Axle Ratio.....	19
4.1 to 1 Axle Ratio.....	20

ber mounting pad which is bolted to the rear bearing retainer and to the top of transmission support. Driving thrust is taken by a rubber thrust pad located between the rear flange of transmission support and a thrust plate attached to rear bearing retainer by the torque ball re-

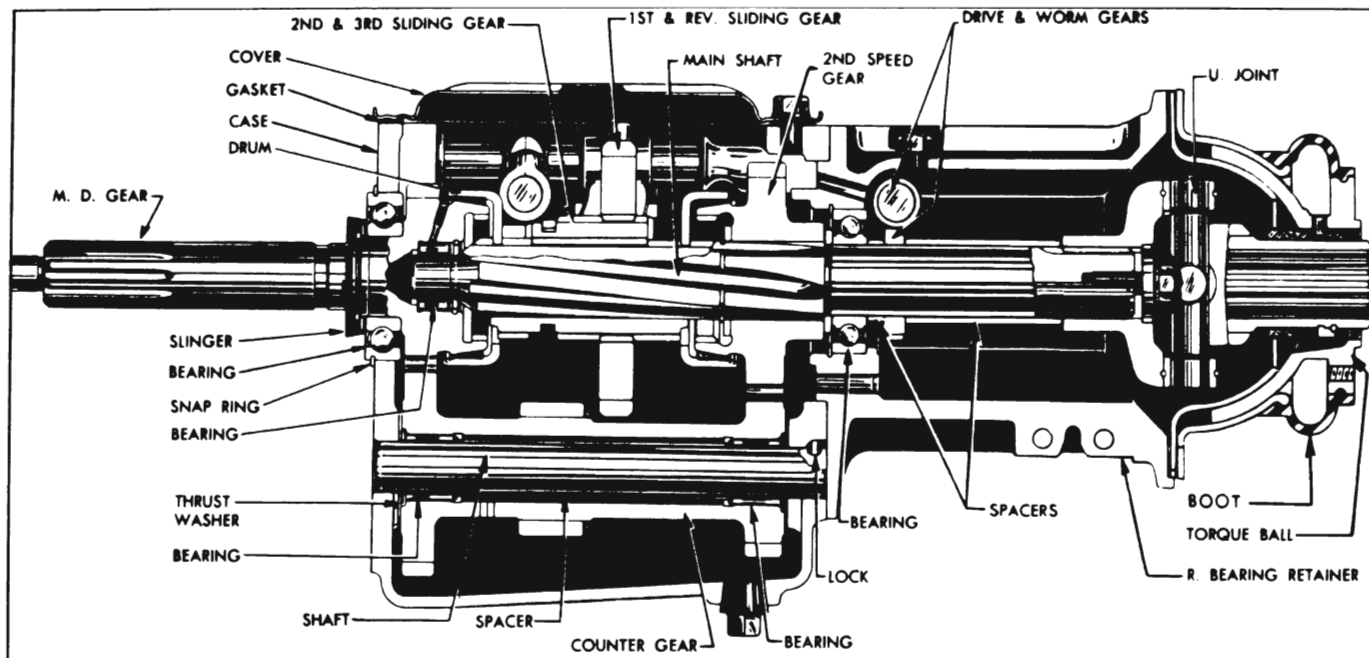

Figure 4-13—Synchronesh Transmission—Series 40-50

4-8 DESCRIPTION OF S-M TRANSMISSION AND UNIVERSAL JOINT

The Synchronesh transmission is standard equipment and Dynaflo Drive is available as optional equipment on *Series 40-50*. On *Series 70*, Dynaflo Drive is standard equipment and the Synchronesh transmission is not available.

a. Transmission Mounting

The Synchronesh transmission is solidly bolted to the rear face of flywheel upper housing, with a heavy paper gasket between, to form a unit assembly with the engine. The transmission main drive gear extends through the clutch driven plate into a single-row-ball pilot bearing seated in the rear end of engine crankshaft. The outer race of main drive gear bearing projects from transmission case to seat in a counterbore in flywheel housing, thus serving as a pilot to center the transmission with engine crankshaft.

The transmission, as well as rear end of engine, is carried on a channel-shaped support or cross member which is bolted to the frame "X" member. The transmission is cushioned on a rub-

ber mounting pad which is bolted to the rear bearing retainer and to the top of transmission support. Driving thrust is taken by a rubber thrust pad located between the rear flange of transmission support and a thrust plate attached to rear bearing retainer by the torque ball re-

b. Transmission Construction

The transmission main drive gear is supported by a ball bearing seated in front wall of transmission case. The ball bearing, which is shielded on rearward side, is pressed against a shoulder on main drive gear and held in place by an oil slinger, washer, and retainer (snap ring). The outer race of bearing is grooved for a snap ring which fits between transmission case and flywheel housing to hold bearing and main drive gear in place. See figure 4-13.

The front end of transmission main shaft is piloted in the bored rear end of main drive gear by a bearing consisting of 14 small steel rollers, which are retained in drive gear by a washer and snap ring. The main shaft is also supported by the transmission rear bearing which seats in transmission rear bearing retainer. The outer race of rear bearing is held in position by a shoulder in bearing retainer and a lock (snap ring) which engages a groove in retainer. The inner race of bearing is clamped against the

main shaft thrust washer by a short spacer, speedometer worm gear, long spacer and universal joint. See figure 4-13.

The transmission counter gear is supported by two roller bearings on a shaft which is held stationary in transmission case by a steel ball seated in recesses in case and rear end of shaft. A tubular spacer and two thrust washers are located between the roller bearings, and a retaining washer is located at outer end of each bearing to hold the rollers in position. End thrust is taken by a bronze thrust washer at each end of counter gear. A hole in hub of counter gear permits lubricant to reach bearings and thrust washers. See figure 4-13.

The reverse idler gear is provided with two bronze bushings and is supported on a shaft which is held stationary by a grooved pin lock driven into holes in transmission case and rear end of shaft. End thrust is taken by a bronze thrust washer at each end of idler gear. Lubricant is fed to thrust washers and bushings through passages in transmission case and a groove cut through the bore of idler gear.

The second speed gear is mounted on the main shaft between two thrust washers and a snap ring, which hold it in position to mesh with the counter gear. It is free to rotate on the main shaft except when engaged by the second and third speed sliding sleeve during second speed operation. The sliding sleeve is splined to the main shaft to transmit drive when sleeve is engaged with either the main drive gear (third speed) or the second speed gear. The sliding

sleeve carries the first and reverse sliding gear on splines so that it also transmits drive to the main shaft in first speed and reverse. See figure 4-13.

c. Shift Mechanism in Transmission

The first and reverse sliding gear is moved forward or rearward from the neutral position by a shifter yoke mounted on a shaft supported in left side of transmission case. The second and third speed sliding sleeve is similarly actuated by a yoke and shaft on right side of case. Each shifter yoke shaft is notched for engagement by one of two shifter levers mounted on a selector shaft which is supported in transmission case at right angle to yoke shaft. The levers are located on selector shaft so that only one lever at a time can engage its yoke shaft. See figure 4-14.

Engagement of a shifter lever with its yoke shaft, to select a gear shift, is obtained by moving selector shaft to right or left as required. This transverse movement of selector shaft is made by a selector lever and shaft which engages a groove in selector shaft. The selector lever shaft extends through transmission case and has a lever on its outer end which is actuated by a selector rod connected to the selector control mechanism in steering column. See figure 4-14.

Forward or rearward movement of the selected shifter yoke shaft, to complete the gear shift, is obtained by rotating the selector shaft. This movement is made by a shift lever mounted

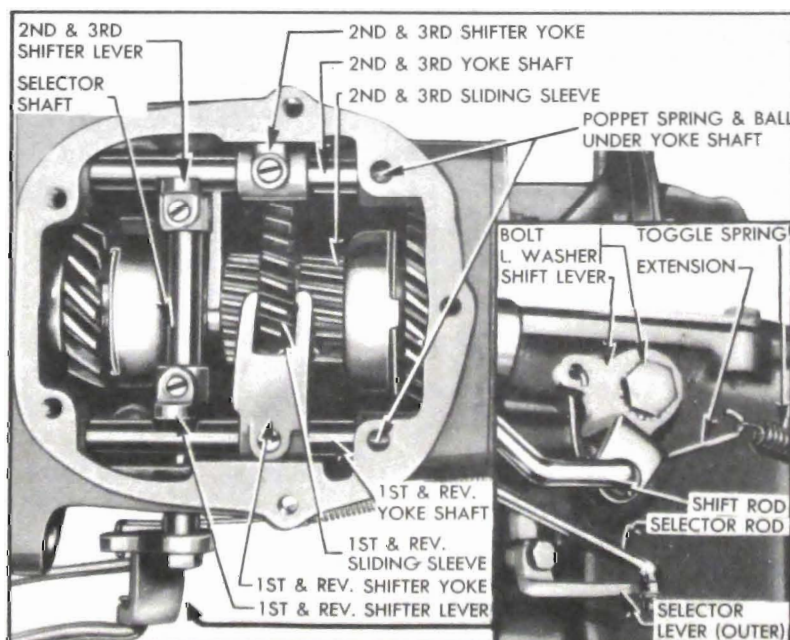

Figure 4-14—Shift Mechanism in Transmission

on outer left end of shaft and actuated by a shift rod connected to the gear shift control mechanism in steering column. A toggle spring and extension attached to shift lever aids in moving the sliding parts. See figure 4-14. A spring loaded poppet ball, housed in a recess in transmission case under each yoke shaft, engages one of three recesses in shaft to hold the shaft in desired position.

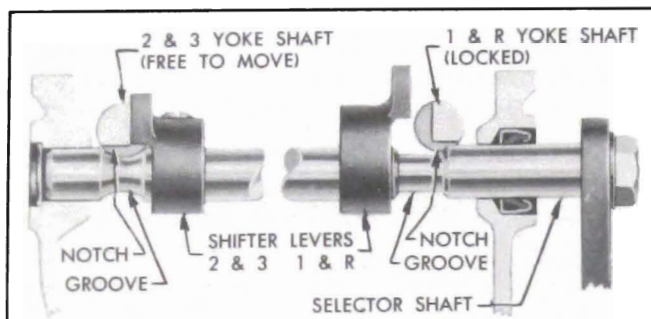

Figure 4-15—Transmission Shift Interlock

An interlock arrangement permits movement of one shifter yoke and shaft only when the opposite yoke shaft is locked in neutral position. The full diameter of selector shaft engages a notch in one yoke shaft to lock it while the opposite yoke shaft is free to move through a groove in the selector shaft. See figure 4-15.

A seal pressed into a recess in transmission case prevents leakage of oil around the extended left end of selector shaft. A welsh plug closes the opening in case at right end of shaft. A cork seal, spring washer, and plain washer prevents leakage of oil around the selector lever shaft. See figure 4-17.

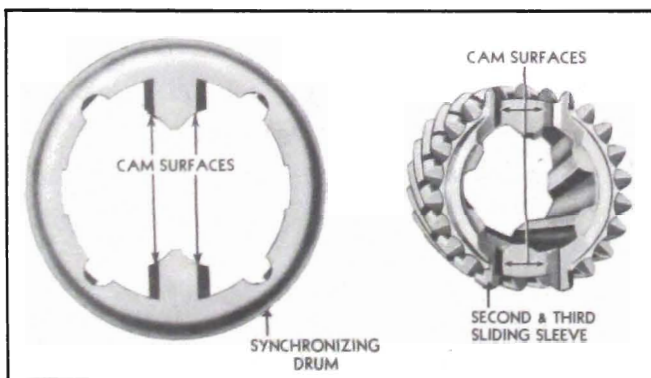

Figure 4-16—Cam Surfaces on Drum and Sleeve

d. Gear Synchronization

Transmission gears are synchronized only when shifting into second and third speeds. When the transmission is shifted into second or third speed, the sliding sleeve and the gear it engages are synchronized in speed through the action of a synchronizing drum. Each drum

is a steel stamping having a bronze insert machined to match a conical surface on the gear, to which drum is loosely attached by a wire retainer. Synchronization is obtained when the beveled cam surfaces of the two slots in sliding sleeve come in contact with the beveled cam surfaces on the two fingers of synchronizing drum. See figure 4-16. This contact of cam surfaces presses the drum against the gear so that gear is brought to the same speed as the sliding sleeve, and the slight angular motion imparted permits the teeth of sliding sleeve and gear to mesh quietly and easily.

e. Universal Joint and Torque Ball

The universal joint is splined to the rear end of transmission main shaft and retained by a heavy steel washer and bolt. It is entirely enclosed by the transmission rear bearing retainer and by the torque ball and retainers which are attached to rear end of the bearing retainer.

The universal joint yokes are provided with hardened and ground steel bushings, held by retainer rings, which provide bearings for the hardened and ground pins of the universal joint cross. The rear yoke is splined internally to engage the propeller shaft, and is ground externally to provide a bearing in a bronze bushing in the torque ball. See figure 4-13.

The torque ball is supported between an inner and outer retainer which are centrally located and bolted to the transmission rear bearing retainer. The retainers are copper plated and the bearing surfaces of the torque ball are also plated to prevent scoring during break-in.

The universal joint, torque ball, and speedometer drive gears are automatically lubricated from the transmission. Oil enters the rear bearing retainer through a hole at the top and returns to transmission through a hole at bottom of retainer. A synthetic rubber boot extends from the outer retainer to the flange of torque ball to provide an external oil seal and an oil seal installed in torque ball at rear end of bronze bushing prevents leakage of oil between transmission and torque tube. A breather or air vent is installed in upper side of the rear bearing retainer to prevent a build up of pressure, due to heat, that would force transmission lubricant out past gaskets and oil seals. See figure 4-13.

f. Speedometer Gears

The speedometer worm gear (driving gear) is mounted on transmission main shaft and held in place by the universal joint and spacers. The

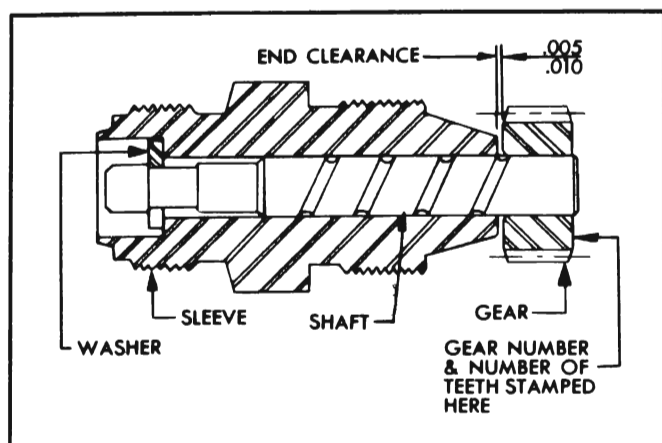

Figure 4-17—Speedometer Driven Gear Assembly

same worm gear is used in all series for all rear axle gear ratios. In changing axle ratios it is only necessary to change the driven gear.

The speedometer driven gear is furnished only as an assembly consisting of sleeve, shaft, retaining washer and gear. See figure 4-17. The number of teeth and a part number are stamped on the side of gear; however, the part number is that of the gear only and is not the number of the driven gear assembly as listed in the Master Parts List.

To insure proper mating of drive and driven gears as well as correct speedometer readings when making a replacement, it is very necessary to install the driven gear assembly specified in the Master Parts List for the particular car model and rear axle ratio. The axle ratio is indicated by numbers stamped on the underside of axle housing.

The driven gear sleeve is threaded into the transmission rear bearing retainer and the speedometer cable is attached to the sleeve by a threaded sleeve on cable casing. The speedometer gears and driven gear shaft are lubricated from the transmission.

4-9 S-M TRANSMISSION SHIFT CONTROL MECHANISM

a. Selector Control Mechanism

The gear shift control lever on steering gear column and the linkage which connects it to the selector shaft in transmission controls the selection of either first and reverse or second and third speed gear shifts. Upward movement of control lever causes selector shaft to move to the left and engage the first and reverse shifter lever with the first and reverse shifter yoke shaft, ready for a shift into first or reverse. Downward movement of control lever similarly causes engagement of the opposite (second and

third) shifter lever with the second and third shifter yoke shaft, ready for a shift into second or third speed. See figure 4-18.

The gear shift control lever pivots on a ball joint formed in outer end of the control lever housing. A spherical shoulder on the lever seats in a similarly shaped fabricated rubber bearing which is supported between the housing nut and a stamped steel bearing seat. The ball shaped inner end of control lever seats in a socket formed in the upper end of the selector control rod, which is located inside the steering gear column jacket. The end of control lever is firmly held in the rod socket by a spring loaded plunger. See figure 4-18.

The upper end of selector control rod is supported in a bearing machined in the control lever housing. The lower end of control rod is connected by a pin to the selector control which is supported on a bracket welded to lower end of the column jacket. The selector control lever is connected to the outer selector lever on transmission by the lower selector rod, which has a trunnion at the forward end for adjustment. The trunnion pin seats in a rubber insulator in the selector control lever to prevent noise at this connection. See figure 4-18.

A return spring connected between the column jacket and upper end of selector control lever operates to pull the gear shift control lever downward. An anti-rattle spring connected between the dash and a clip on lower selector rod also assists in pulling the control lever downward. In the neutral position, therefore, the control is always in position for a shift into second or third speed and must be raised for a shift into first or reverse.

b. Gear Shift Control Mechanism

Shifting into gear after selection has taken place, or shifting out of gear is controlled by the shift control lever on steering gear column, the control shaft inside the column, and the linkage which connects the control shaft to the shaft lever on selector shaft in transmission. Forward movement of control lever causes rotation of the selector shaft to produce a shift into reverse or second speed, depending on the selection. Rearward movement of control lever similarly produces a shift into first or third speed. See figure 4-18.

The housing in which the shift control lever is mounted is a slip fit over the upper end of the tubular control shaft, which encircles the steer-

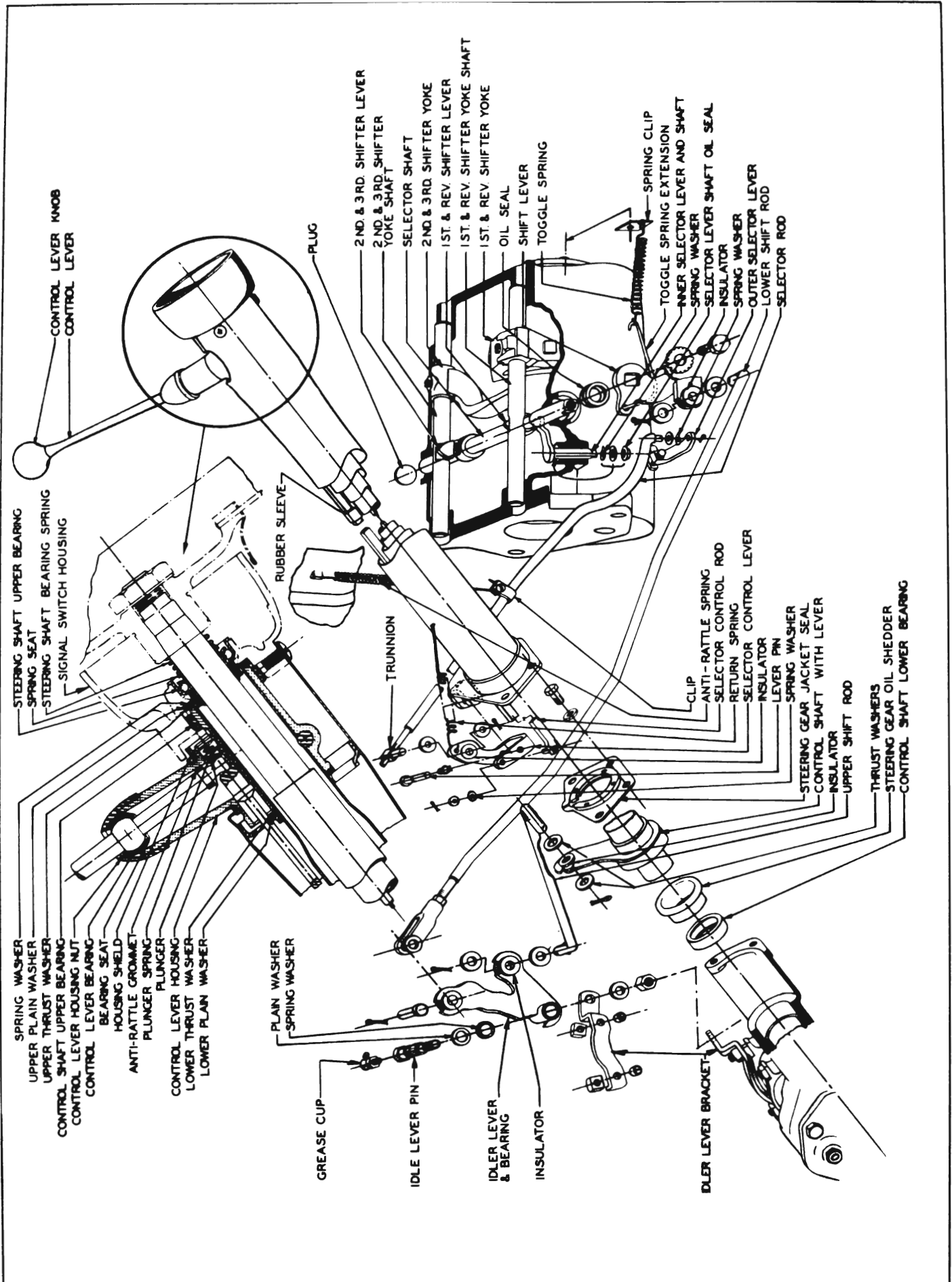

Figure 4-18—S-M Transmission Shift Mechanism—Series 40-50

ing shaft. The control shaft is slotted in two places to key to the lever housing, which is held tight on shaft by a clamp screw. The upper end of housing and shaft assembly is supported in a metal and fabric bearing seated in the signal switch housing. Upward thrust of the assembly is taken by a fabric thrust washer, plain washer, and spring washer placed between the lever housing and switch housing. Downward thrust is taken by a fabric thrust washer and a plain washer placed between lever housing and a plate welded into the column jacket. See figure 4-18.

The lower end of control shaft is reduced in diameter and is supported by a metal and fabric bearing seated in the steering gear housing. An oil shedder is pressed into steering gear housing over the bearing and the shedder is covered by a cup welded to the control shaft, to form a seal against entrance of dirt and water.

A lever welded to control shaft is connected by a short upper shift rod to the idler lever mounted on a bracket attached to steering gear housing. The idler lever is bushed and carried on a shouldered pin attached to bracket by a nut and washer. The pin is drilled and fitted with a grease fitting for lubrication. A long lower shift rod, provided with an adjustable clevis, connects the idler lever to the shift lever on selector shaft in transmission. Rubber insulators seated in the levers prevent noise at the connection with both ends of both shift rods. See figure 4-18.

4-10 S-M TRANSMISSION TROUBLE DIAGNOSIS

a. Hard Shifting and Block-out

Hard shifting may be caused either by conditions in shift control mechanism in steering column or by conditions in transmission assembly. Disconnect lower shift rod at idler lever to determine which unit is at fault.

Conditions in shift control mechanism which may cause hard shifting are: (1) Control shaft upper or lower bearing scored or distorted. (2) Control lever housing upper thrust washer broken or improperly installed in signal switch housing. (3) Selector control rod bent or rubber sleeves binding against jacket.

Conditions in transmission assembly which may cause hard shifting are. (1) If there is excessive resistance at start of shift, shifter yoke shaft poppet spring probably too stiff. (2) Shifter yoke shaft may be bent. (3) Selector

shaft bent, or binding in oil seal may cause hard shifting or hard selection.

Block-out of second or third gear may be caused by scored synchronizing drums or the cones on gears. Rough cam surfaces on ends of sliding sleeve or on synchronizing drum will also cause block-out.

b. Low and Reverse Gear Clash

Transmission gears can be made to clash by shifting into low or reverse gear too quickly after clutch pedal is depressed, even though clutch is in perfect working order. This is because inertia of clutch driven plate causes the plate to spin until it is stopped by friction of transmission and transmission lubricant. With warm transmission lubricant and low friction transmission bearings, a reasonable amount of spin is to be expected. The spin does not occur when shifting quickly into second or high gear because the synchronizing unit stops the driven plate.

To eliminate gear clash, sufficient time MUST be allowed before shifting into low after pedal is depressed or else starts must be made in second gear. There is no objection to making starts in second gear on level ground since the clutch slippage under ordinary driving conditions is not sufficient to produce enough heat to damage driven plate facings.

If gear clash continues after allowing proper time for clutch driven plate to stop, check clutch pedal lash and adjust to specified limits. See paragraph 4-4. In exceptional cases of driven plate spinning, clutch pedal lash should be *maintained* at $1/2$ ". Make sure that idle speed of engine when hot is 450 RPM. A faster idle aggravates driven plate spinning.

Conditions within the transmission which may cause gear clash are: (1) Faulty synchronizing drums or cone surfaces; (2) Excessive main shaft end play. Gear clash also may be caused by a dragging clutch plate. See paragraph 4-3 (d).

c. Noise in Neutral

With car standing, engine running, and transmission in neutral, the transmission parts in operation are: main drive gear and bearing, counter gear and bearings, reverse idler gear, second speed gear, main shaft pilot bearing. Disengaging clutch will stop movement of all these parts. By disengaging and engaging clutch it can be determined whether noise originates in these transmission parts and whether the

noise is normal. Noise in neutral in the form of a constant regular click is usually caused by a nicked gear or bearing.

d. Gear Noise

Some gear noise is to be expected in all except third speed. Comparison with another car is the only means of determining whether or not gear noise is excessive. Before removing transmission for correction of gear noise determine by test which gears are noisy under load, so that these can be thoroughly inspected when removed.

e. Gear Rattle During Acceleration

Improperly calibrated clutch driven plate, faulty crankshaft balancer, or scored rear axle gears may cause rattle in transmission in third speed, on acceleration. Rattles occurring on wide open throttle between 40 and 60 MPH are usually caused by improper clutch driven plate dampening; a new driven plate should be installed if rattles are objectionable.

f. Noise When Shifting out of First or Reverse

Shifting out of first or reverse very slowly will usually result in some noise just as the gears disengage. This is normal because of the gear pointing necessary for easy engagement.

Abnormal noise during normally fast shift may be caused by improper clutch release. Check clutch pedal lash and adjust. See paragraph 4-4.

Abnormal noise during normally fast shift, when clutch release is satisfactory, may be caused by damage to pointing on engaging side of teeth on counter gear, reverse idler gear or first and reverse sliding gear. Noise when disengaging both first and reverse, indicates that fault is with sliding gear only. Noise when disengaging reverse only indicates reverse idler gear at fault. Noise when disengaging first speed only indicates counter gear at fault. *Tests must be made by disengaging gears while car is still in motion.*

g. Gear Jump-out

In any case of gear jump-out, first check the adjustment of gear shift control mechanism as described in paragraph 4-11. Make certain that poppet balls have full engagement in notches in shifter yoke shaft in all speed positions and neutral. Also make certain that toggle spring extension is not distorted so that it contacts the selector shaft. If these items do not correct gear jump-out, remove transmission for examination of parts.

Gear jumping out of third speed may be caused by misalignment between the flywheel housing and crankshaft. See paragraph 2-33 for alignment correction procedure.

Gear jumping out of third speed also may be caused by excessive run-out of front face of transmission case. See paragraph 4-14 (subpar. b) for checking procedure.

Gear jump-out in any transmission speed position may be caused by loose fit of bearings or bushings involved, weak poppet springs, loose fit of sliding sleeve on main shaft, loose fit of sliding gear on sliding sleeve, worn teeth on mating gears. All items should be carefully inspected.

h. Transmission Lubricant Passing to Rear Axle

Transmission lubricant may pass into rear axle assembly as a result of:

- (1) Scored universal joint or bushing.
- (2) Clearance of more than .006" between universal joint and bushing in torque ball.
- (3) Worn oil seal in torque ball.
- (4) Loose torque ball adjustment.
- (5) Excessive run-out of front end of propeller shaft.

i. Scored or Broken Gear Teeth

Gear teeth will be seriously damaged and possibly broken, by failure of car operator to fully engage gears on every shift before engaging clutch and applying engine power.

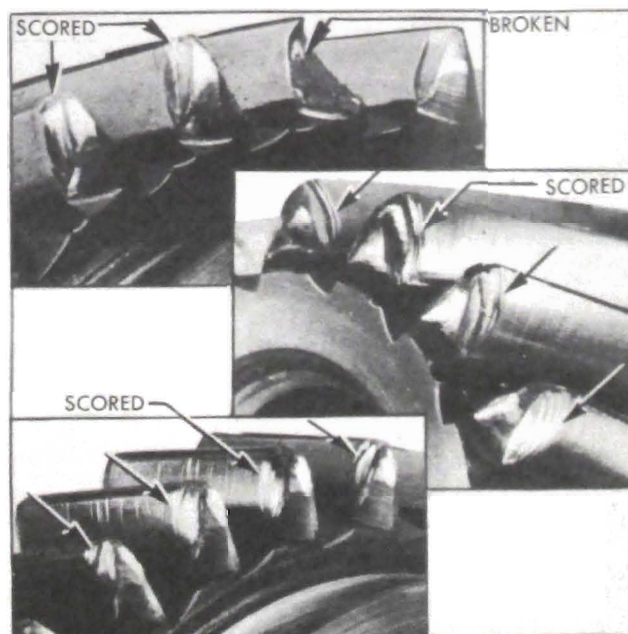

Figure 4-19—Gear Teeth Damaged by Improper Gear Shifting

The type of damage resulting from failure to obtain full engagement is shown in figure 4-19. The conditions illustrated were produced on *new gears* intentionally shifted improperly a few times to determine what damage would result.

Considerable damage to gears and bearings will result from running at abnormal speeds in reverse, first, and second speed gears. This practice is also detrimental to the engine.

4-11 ADJUSTMENT OF SHIFT CONTROLS—REPLACEMENT OF PARTS

a. Selector Control Adjustment

The following steps are required to insure that the shifter levers in transmission make full engagement with the shifter yoke shafts as selected. See figure 4-18.

1. Shift transmission to neutral and disconnect selector rod from selector control lever.

2. Inspect rubber insulator in selector control lever and replace insulator if worn. Make sure that lever return spring is strong enough to pull selector control lever up so that the gear shift control lever is held all the way down.

3. Move selector rod back and forth to make sure that selector shaft in transmission moves freely. A bind at this point will prevent return spring from automatically dropping shift control lever to second speed side on shift from first to second speed.

4. Hold selector rod to the rear as far as possible and adjust trunnion until trunnion pin is centered in hole in selector control lever insulator.

5. Connect trunnion to selector control lever with a fiber washer on each side of insulator and lock with cotter pin.

b. Gear Shift Control Adjustment

The following steps are required to insure that gears are fully engaged on all shifts. See figure 4-18.

1. Shift transmission into second speed and disconnect lower shift rod from the shift idler lever.

2. Inspect for wear and lost motion in rubber insulators located in control shaft lever, idler lever, and shift lever on selector shaft; replace any worn insulators. If idler lever has excessive play on idler lever pin, replace worn parts.

3. While pulling forward on lower shift rod

to insure full engagement in second speed, adjust clevis on shift rod so that when clevis is connected to idler lever a clearance of $\frac{1}{8}$ " exists between the shift control lever housing and the edge of opening in steering gear column jacket.

4. With lower shift rod connected to idler lever and lock nut tightened against clevis, shift into third speed. A clearance of approximately $\frac{1}{8}$ " should exist between control lever housing and column jacket. Make certain that specified clearance exists between control lever housing and column jacket in all speed positions.

c. Replacement of Shift Control Parts

The gear shift control lever, bearing, and bearing seat may be removed by unscrewing the control lever housing nut. Unscrew knob from lever to remove housing nut. A rubber anti-rattle grommet fits into a groove in the inner end of control lever. When installing a new bearing on control lever, the large diameter of bearing must be toward the lever knob. Before installing control lever, coat inner end and socket in selector red with Lubriplate. During installation of lever be careful to draw housing nut tight so that shoulder in nut will seat against flange of bearing seat and lock the seat in place.

The control shaft upper bearing and control lever housing upper thrust washer may be replaced by removing the signal switch housing. The procedure for replacement of these parts is given in paragraph 7-7.

Replacement of selector rod, control shaft, and lower bearing requires removal of steering column jacket. The steering gear should be removed, or at least moved down from instrument panel to provide proper working space and avoid damaging interior of body. Replacement of these parts is covered in paragraph 7-9 covering disassembly and assembly of steering gear.

4-12 ADJUSTMENT OF TORQUE BALL

Correct adjustment of the torque ball is very important. If torque ball is loose and has end play it will be noisy and will act as a pump to cause leakage of transmission lubricant. If torque ball is too tight, it will cause transmission misalignment, scoring of ball and retainers, and may cause breakage of bolts which attached torque ball to torque tube.

1. Disconnect rear axle assembly and move it back out of the way (par. 5-7).

2. Disconnect thrust plate from the rubber thrust pad on transmission support, then re-

move torque ball boot, thrust plate, gasket, torque ball retainers, and shims from rear bearing retainer. **NOTE:** *Mark top edge of outer retainer before removal so that retainer can be reinstalled in original position.*

3. Clean and inspect spherical surfaces of torque ball and both retainers. Inspect bushing and universal joint oil seal in torque ball. Inspect torque ball boot. Replace parts which are excessively worn, damaged or scored.

4. When installing a new universal joint oil seal in torque ball, place seal in position with the feather edge pointing into torque ball, then press seal squarely into place, using a flat piece of metal to avoid distorting seal. Press new seal flush with boss on flange of torque ball. **NOTE:** *Oil seal should be stored in neatsfoot oil to keep leather soft and pliable. Do not use seal having a hard, dry leather.*

5. Prepare two $\frac{3}{8}$ " headless guide pins $1\frac{3}{8}$ " long, having $\frac{3}{8}$ "-16 threads $\frac{1}{2}$ " long and screw-driver slots cut in opposite end. Install guide pins in upper bolt holes in rear bearing retainer flange. See figure 4-22.

6. Place one gasket or shim (having 3 notches in outer edge) and the inner retainer on guide pins, with oil drain hole and notch in edge of retainer straight down.

7. Lubricate leather oil seal and bearing surfaces of torque ball and retainers with transmission lubricant. Place torque ball in outer retainer so that "TOP" mark on ball and the marked edge of retainer are together.

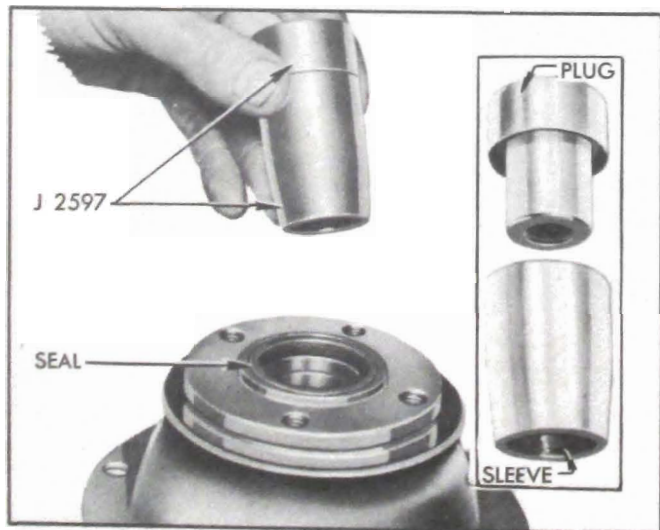

Figure 4-20—Torque Ball Installing Tool J 2597

8. Assemble sleeve and plug of Installing Tool J 2597 together (fig. 4-20), then push tool through rear side of oil seal until the leather edge is on the plug, at which time the sleeve will drop off the plug. See figure 4-21.

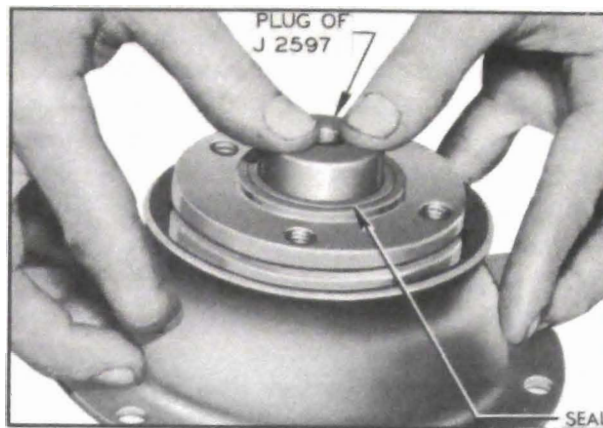

Figure 4-21—Pushing Installing Tool into Universal Joint Oil Seal

9. Install torque ball and outer retainer with "TOP" sides up, using shims of sufficient thickness to fill the space between flanges of inner and outer retainers. Hold plug of installing tool firmly against end of universal joint until oil seal has moved forward upon the universal joint, then remove the plug. See figure 4-22.

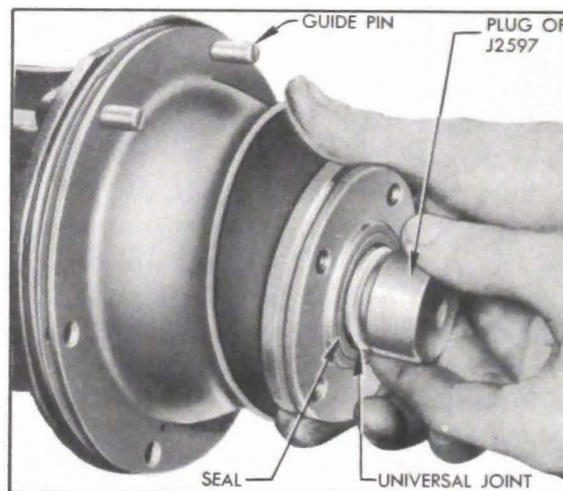

Figure 4-22—Installing Torque Ball and Retainer

10. Install thrust plate and all retainer attaching bolts, removing guide pins and placing the short bolts in these holes; *do not tighten bolts*. Thrust plate must be installed to prevent creeping or distortion of outer retainer.

11. Prepare a hardwood club for adjusting torque ball as shown in figure 4-23.

12. Insert the hardwood club in universal joint and while moving torque ball up, down, and sideways tighten retainer bolts evenly. **CAUTION:** *It is absolutely necessary to continually move torque ball while tightening bolts in order to properly center the ball and retainers.* If torque ball binds as bolts are tightened, tap outer retainer lightly at several points, using rawhide or other soft mallet. This will usually relieve the binding condition.

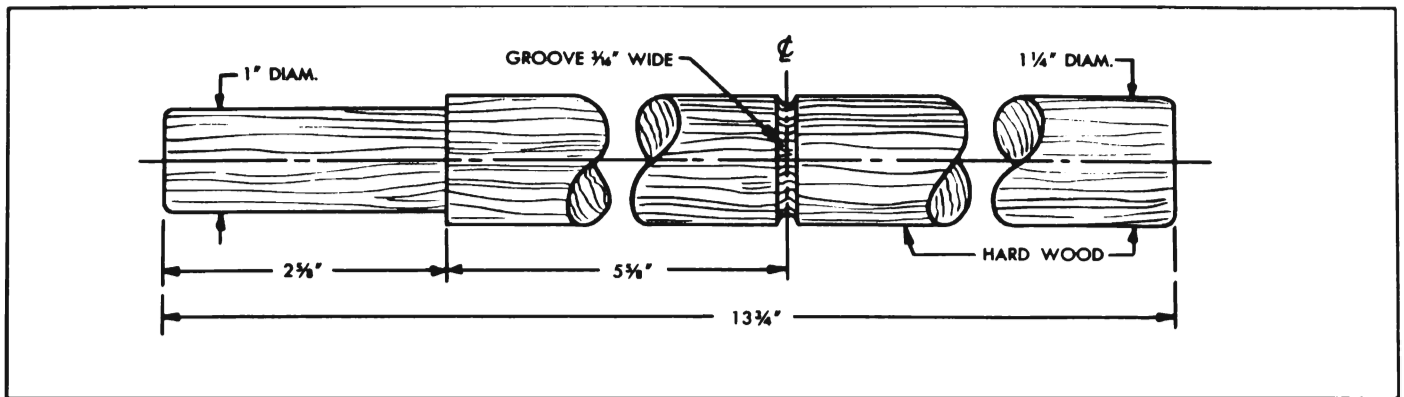

Figure 4-23—Club for Adjusting Torque Ball

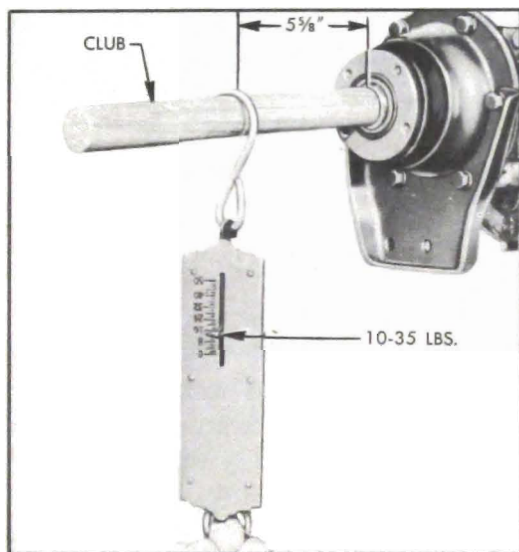

Figure 4-24—Checking Torque Ball Drag

13. Attach spring scale to club at groove located $5\frac{5}{8}$ " from end of universal joint and test pull required to move torque ball when all bolts are tight. See figure 4-24. A drag of 10 to 35 pounds should be obtained. If torque ball is too tight or too loose, loosen bolts and repeat the centering and tightening operation, then recheck drag with club and spring scale.

14. If torque ball is too tight after repeating the centering and tightening operation remove outer retainer and increase total thickness of shims; if ball is too loose, decrease total thickness of shims. Shims are furnished under Group 5.560 in four thicknesses, and are notched on outer edge for identification as follows:

Thickness	Notches
.000"-.006"	3
.009"-.011"	2
.011"-.013"	1
.013"-.015"	None

15. Always use Installing Tool J 2597 (fig. 4-20) when installing torque ball to avoid damage to oil seal.

After changing shims always install ball and retainer with top sides up and use the centering, tightening, and checking procedures specified in steps 12 and 13 above.

Final adjustment must provide a drag of 10 to 35 pounds on club with a $5\frac{5}{8}$ " leverage. See figure 4-24.

16. Install torque ball boot. Turn the large end back over small end, engage rib in small end in groove on flange of torque ball, then turn large end forward to engage rear end of outer retainer.

17. Install shims between thrust plate and thrust pad (fig. 4-28) and tighten thrust pad stud nuts. Connect rear axle assembly (par. 5-7).

4-13 REMOVAL AND INSTALLATION OF S-M TRANSMISSION

CAUTION: *The rear end of engine must be firmly supported during removal and installation of the transmission. The use of a jack or blocks is dangerous because of the possibility of slipping and letting the engine fall.*

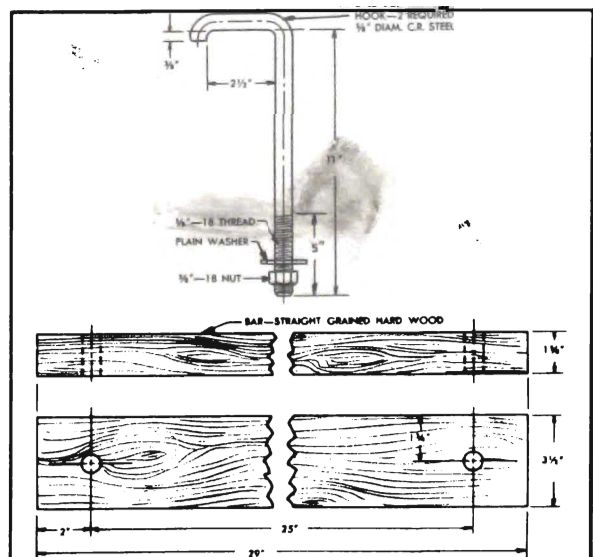

Figure 4-25—Engine Support Bar and Hooks

A safe and convenient engine support bar with two hooks can be made locally from the details given in figure 4-25.

a. Removal of Transmission

1. Disconnect rear axle assembly and move it back out of the way (par. 5-7).

2. Drain transmission lubricant. Fill with clean gasoline or kerosene and run transmission in neutral for about 15 seconds. Drain cleaner.

3. Disconnect speedometer cable, lower shift rod, and lower selector rod. Remove toggle spring and extension, remove shift lever and lock washer from selector shaft and remove outer selector lever, to provide clearance for removing transmission to flywheel housing bolts. **Hold shift lever** in neutral while removing attaching bolt, to avoid damaging shifter lever on shaft inside transmission.

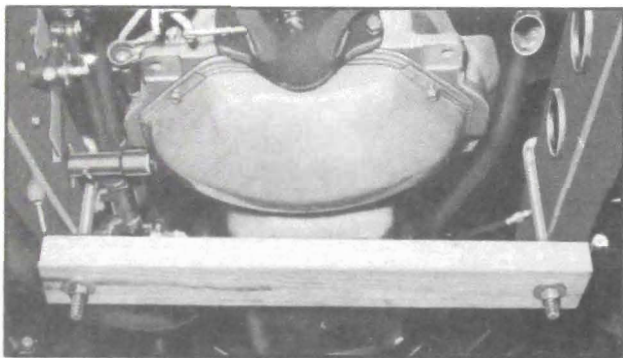

Figure 4-26—Support Bar under Rear End of Engine

4. Support rear end of engine by installing support bar (fig. 4-25) under rear end of lower crankcase. Place left side hook over frame between brake master cylinder and clutch release equalizer. Tighten nuts on both hooks evenly. See figure 4-26.

5. Disconnect rubber thrust pad from transmission support by removing three nuts and plate, then lift out shims located between support and transmission thrust pad. Remove two bolts and plate which attach transmission mounting pad to the support then raise engine to relieve load on transmission support by tightening nuts on engine support bar hooks. Remove support from frame X member and remove thrust pad from thrust plate.

6. Remove the two top transmission to flywheel housing bolts and install Guide Pins J851 to support transmission. See figure 4-27. Remove lower bolts, then move transmission straight back and lower to floor. **CAUTION:** *If guide pins are not used and weight of transmis-*

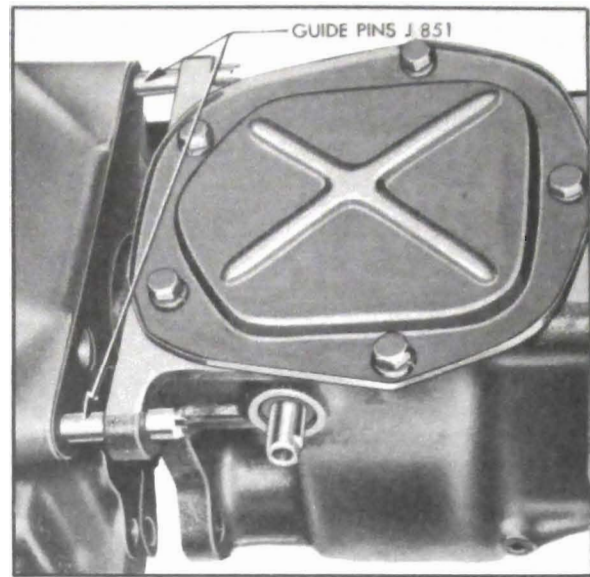

Figure 4-27—Transmission Guide Pins J 851

sion is allowed to rest on main drive gear in clutch driven plate hub, the driven plate will be damaged.

b. Installation of Transmission

1. Lightly coat the splines on end of main drive gear with Lubriplate for a distance of not more than 1". Do not apply an excess that will push off at driven plate hub and get on driven plate facings.

2. Make certain that front face of transmission case and face of flywheel housing are absolutely clean. Install Guide Pins J 851 in upper bolt holes in housing (fig. 4-27) and install a new transmission gasket. Make certain that spring washer is in place behind clutch release bearing support in housing.

3. Lift transmission into place and fully support it until the main drive gear bearing enters flywheel housing. *Clutch driven plate will be damaged if guide pins are not used and weight of transmission is allowed to rest on main drive gear in driven plate hub.*

4. Install lower transmission attaching bolts, then the upper bolts, and tighten all bolts evenly and securely. **CAUTION:** *If a gap exists between transmission case and flywheel housing do not tighten bolts as case may be broken. Remove transmission and check position of main drive gear bearing snap ring, which may have slipped out of place during installation.*

5. Install rubber thrust pad on thrust plate attached to torque ball. Install transmission support and attach transmission mounting pad to the support with bolt plate and self-locking nuts. Remove support bar from under the engine so

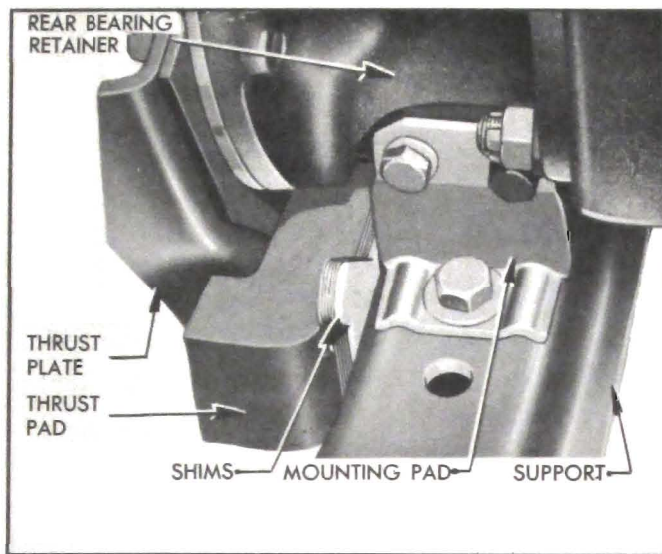

Figure 4-28—Transmission Mounting Pad, Thrust Pad and Shims

that full weight rests on transmission mounting pad.

6. With engine and transmission resting freely and normally on mountings, install sufficient shims between the thrust pad and transmission support to fill the existing space. Insert shims from above with tabs on right side, then install the bolt plate and three nuts which attach thrust pad to support. See figure 4-28.

7. Connect speedometer cable. Install outer selector lever, shift lever, toggle spring and extension. *Hold shift lever* in neutral while installing and tightening attaching bolt and lock washer to avoid damaging shifter levers on selector shaft. Install toggle spring and extension so that extension passes underneath selector shaft.

8. Connect lower shift rod and selector rod to their levers and check adjustment as described in paragraph 4-11.

9. Place $\frac{7}{8}$ pint of transmission lubricant in transmission. In addition, inject $\frac{1}{2}$ pint of transmission lubricant through universal joint yoke. See paragraph 1-1 for specified lubricant.

10. Install rear axle assembly as described in paragraph 5-7.

11. Road test car and check transmission for

- a. Proper shifting into all speeds.
- b. Correct synchronization when shifting into second and third speed.
- c. First and second speed slip-out, on drive and coast.
- d. Gear, bearing, or shifter yoke noises in all speeds and neutral.
- e. Rattles in shaft control mechanism.

4-14 DISASSEMBLY, INSPECTION AND ASSEMBLY OF S-M TRANSMISSION

Some form of fixture for securely holding the transmission during disassembly and assembly is essential. The transmission stand shown in figure 4-29 may be made locally from details given in BPS 2.222, or figure 4-36 in the 1948-49 Buick Shop Manual. If a stand is not desired, the upper section may be mounted on a work bench. *Do not clamp the transmission case in a vise.*

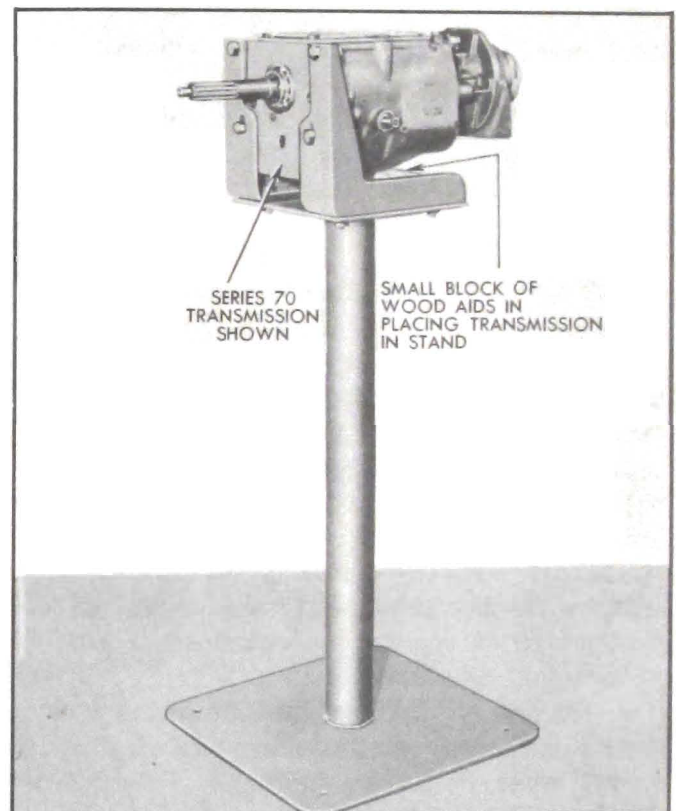

Figure 4-29—Transmission Supported in Stand

a. Disassembly of Transmission

1. Thoroughly clean all dirt from exterior of transmission to avoid getting dirt into bearings when transmission is opened. Remove transmission cover and gasket.

2. Lock transmission in third speed to prevent sliding sleeve and sliding gear from dropping, then remove transmission rear bearing retainer, universal joint, torque ball, and main shaft as an assembly.

3. Remove the four set screws from shifter levers and shifter yokes, using Remover J 2895. See figure 4-30.

4. Drive selector shaft out through right side of transmission case, using babbitt hammer. Welsh plug in right side of case will be driven

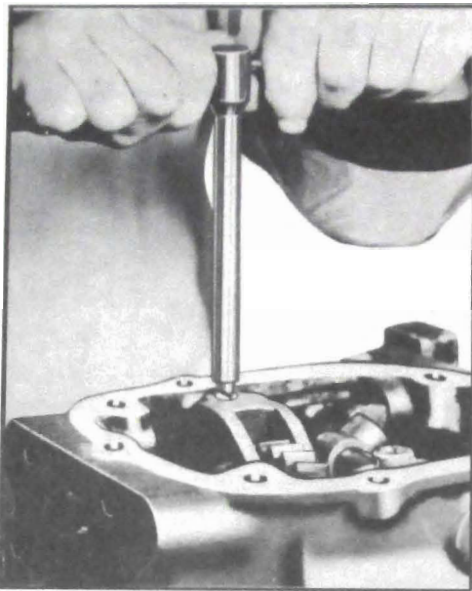

Figure 4-30—Removing Set Screw with Remover J 2895

out by shaft. Do not let shifter levers drop into case.

5. Remove shifter yokes and shafts by pushing shafts out through front of transmission case, using care to prevent poppet balls from jumping out. The welsh plug in front end of case will be driven out by the second and third shifter yoke shaft. Remove poppet balls and springs. **NOTE:** *If poppet balls and springs are not to be replaced the shafts may be pushed to rear of case far enough to release the yokes while holding poppet balls in place.*

6. Remove sliding gear and the sliding sleeve, then remove the selector lever and shaft with spring washer, flat washer, and oil seal from transmission case.

7. Remove the counter gear shaft and lock ball by driving shaft out through rear end of transmission case, using Bearing Loader J 1334 and a babbitt hammer. Make sure that bearing loader follows the shaft closely so that counter gear bearings and thrust washers will be held in place. Allow counter gear to rest on bottom of case.

8. Remove the snap ring from main drive gear bearing and tap drive gear and bearing assembly toward rear of transmission case to remove it.

9. Carefully raise counter gear out of case so that bearing loader and counter gear bearings will not fall out. Remove all thrust washers.

10. Drive reverse idler gear shaft lock into the shaft, then remove shaft, idler gear, and thrust washer.

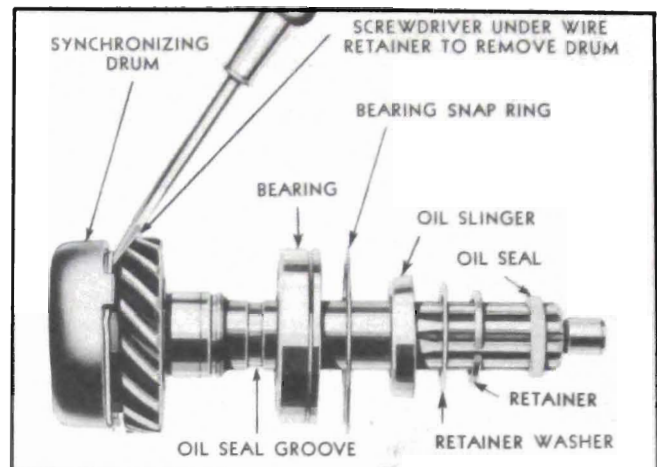

Figure 4-31—Disassembly of Main Drive Gear

11. Disassemble main drive gear if any parts are to be replaced. Remove synchronizing drum by prying retainer over shoulder on gear, leaving retainer in drum. Remove oil seal, retainer (snap ring), washer, and oil slinger from drive gear, then remove bearing by jarring shaft on block of wood or lead. See figure 4-31. Remove main shaft pilot roller bearing by removing retainer (snap ring) and retainer washer.

NOTE: *If work to be done requires disassembly of rear bearing retainer, proceed with the following steps.*

12. Mount rear bearing retainer securely in a vise.

13. Remove second speed synchronizing drum by prying retainer over shoulder on second speed gear, leaving retainer in drum. Remove snap ring from main shaft then remove thrust washer and second speed gear from main shaft.

14. Remove speedometer driven gear.

15. Mark the top edge of outer retainer so that it can be reinstalled in original position. Remove thrust plate and gasket, retainers, shims and torque ball from rear bearing retainer.

16. Remove retaining bolt and washer then pull universal joint from main shaft, using Puller J682-A. To use the puller, install the pressure plug in transmission main shaft, insert puller body in universal joint rear yoke and install "C" washer in groove in puller body on front side of yoke, then turn screw handle clockwise. See figure 4-32. Remove universal joint spacer from main shaft.

17. Remove transmission rear bearing lock (snap ring), then remove main shaft and bearing from retainer by tapping rear end of shaft with babbitt hammer or hardwood block.

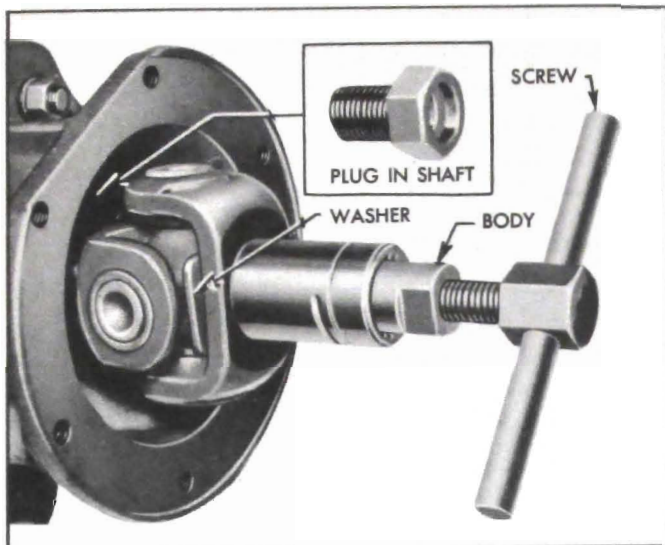

Figure 4-32—Removing Universal Joint with Puller J 682-A

18. Remove speedometer worm gear, spacer, bearing and thrust washer from main shaft, using Puller J1134-H to remove worm gear and bearing. See figure 4-33.

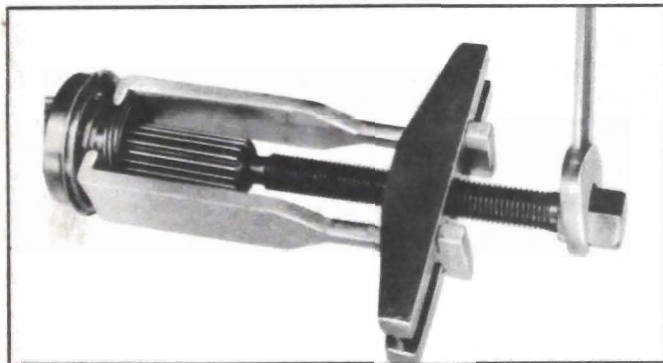

Figure 4-33—Removing Worm Gear with Puller J 1134-H

b. Cleaning and Inspection of Transmission Parts

Clean and inspect all ball and roller bearings as described under Bearing Service (par. 1-11 and 1-12). Thoroughly clean all other parts except rubber mountings in CLEAN solvent and wipe dry with CLEAN cloths. Inspect parts as follows:

(1) *Gears and Shafts.* Carefully inspect teeth and other ground surfaces of all gears for wear, scoring, pitting, chips, nicks, and burrs. Do not confuse manufacturing cutter marks with scores or pits. Conical surfaces of gears where contacted by synchronizing drums must be smooth and free of burrs. Slight scores or burrs may be honed off with a fine stone, however, if any gear is chipped or excessively worn it should be replaced.

Inspect all shafts for wear roughness on bearing surfaces. Check fit of gears on shafts upon

which they are mounted. The sliding sleeve must slide freely on splined section of main shaft, but without appreciable backlash.

(2) *Synchronizing Drums.* The cam surfaces of synchronizing drums must be smooth. The conical surfaces of synchronizing drums must be free of burrs or scores, and oil grooves must be clean. *Never polish this surface or change the angle.*

(3) *Selector Shaft, Shifter Yokes and Shafts, Toggle Spring Extension.* Check selector shaft and shifter yoke shafts on a flat surface to see whether they are bent. A bent shaft will cause hard shifting, and should be replaced. If a shifter yoke is bent or has rough contact surfaces it will cause hard shifting and noise, therefore, it should be replaced. Replace poppet springs if distorted or of doubtful strength.

Check toggle spring extension to make sure it is not distorted. An improperly shaped extension will bear against the selector shaft and actually tend to pull transmission out of second speed. Figure 4-34 shows the correct shape for extension. A bent extension should be reshaped to dimension shown, or replaced.

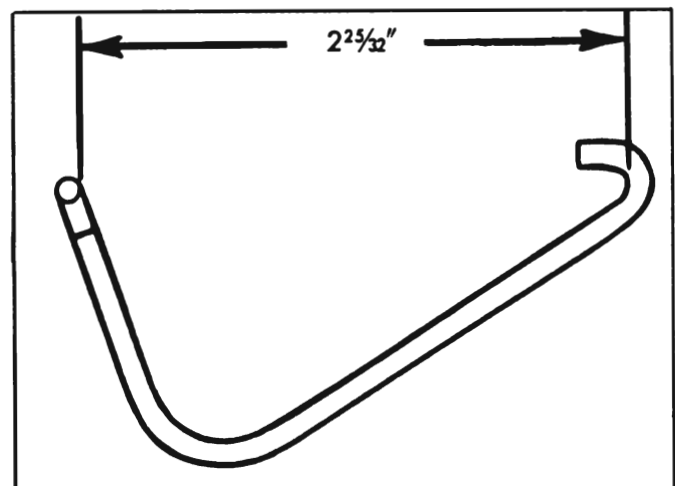

Figure 4-34—Toggle Spring Extension

(4) *Universal Joint.* Inspect universal joint for wear in bearings and for fit on main shaft and propeller shaft, and in torque ball bushing. Allowable play of spider pins in bushings is .002" to .004". Allowable backlash of rear yoke on propeller shaft splines is .0005" to .0045". The front yoke must be a tight fit, rotatively, on main shaft to prevent "snap" when alternating car movement between forward and reverse. The rear yoke of universal joint and bushing in torque ball must be free of scores and not worn excessively; clearance between these parts should be .004" to .006".

(5) *Torque Ball.* If torque ball and retainers

are scored or pitted on bearing surfaces they should be replaced. Replace torque ball boot if worn or damaged. Replace oil seal in torque ball if it is worn. When installing a new seal, place it in position with the feather edge pointing into torque ball, then press seal squarely into place, using a flat piece of metal to avoid distorting seal. Press new seal flush with boss on flange of torque ball. NOTE: Oil seal should be stored in neatsfoot oil to keep leather soft and pliable. Do not use seal having a hard, dry leather.

(6) *Transmission Mounting and Thrust Pad.* Inspect mounting and thrust pads. Replace either part if rubber is broken or deteriorated.

(7) *Transmission Case.* Inspect selector shaft oil seal in case. If worn, or there was evidence of oil leakage past the seal, remove it and install a new one. Coat outer surface of seal with white lead or other sealing compound and install seal with feather edge pointing inward.

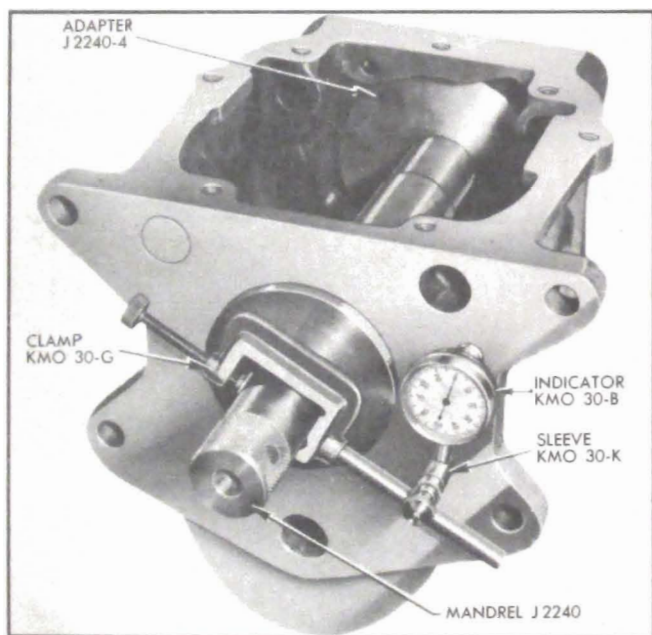

Figure 4-35—Checking Run-out of Transmission Case

If the transmission had been jumping out of third speed, the alignment of flywheel housing with engine crankshaft should be checked as described in paragraph 2-33 and front face of transmission case should be checked for run-out using Checking Fixture J 2240, which may be borrowed from a Buick Zone Office or may be made locally from dimensions given in BPS 2.200, figure 7.

a. Install the adapter and mandrel in case, then mount dial indicator on mandrel so that indicator stem bears against front face of transmission case 3" from center of mandrel. See figure 4-35.

b. Rotate mandrel while pressing it against case and note dial indicator reading. Total indicator reading should not exceed .003". If runout exceeds .003", replace transmission case with one that checks within the allowable limit on run-out.

c. Assembly of Transmission

Assemble the transmission by reversing the sequence of steps given for disassembly. In addition, observe the following instructions that apply to assembly.

(1) *Condition of Parts.* Make certain that all parts are absolutely clean and that gears and synchronizing drums are free of nicks or burrs. Use all new gaskets and oil seals or packings to insure against leakage of lubricants. Use all new snap rings, and retainers of snap ring type. Snap rings are frequently distorted during removal and are difficult to true up satisfactorily for further service.

(2) *Bearings.* Observe instructions given under Bearing Service (1-9) on proper installation of ball bearings. Coat bearings with clean transmission lubricant at time of installation, to insure initial lubrication.

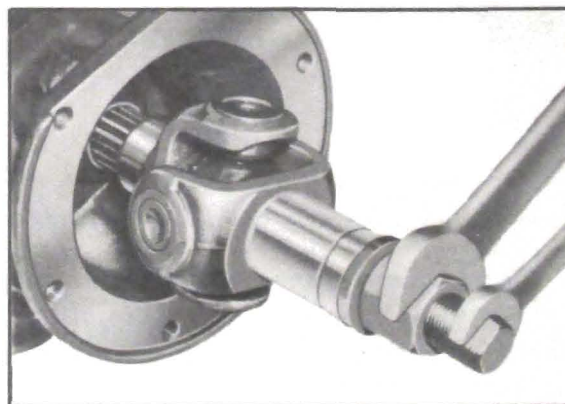

Figure 4-36—Installing Universal Joint with Replacer J 865

(3) *Universal Joint.* Use Replacer J 865 to install universal joint on main shaft. See figure 4-36.

(4) *Torque Ball.* Follow instructions given in paragraph 4-12 for installation and adjustment of torque ball.

(5) *Main Drive Gear Bearing.* Install main drive gear bearing with the shielded side toward gear teeth.

(6) *Reverse Idler Gear Shaft Lock.* Always use a new lock and coat with white lead or other sealing compound before installation, to prevent oil leaks. Drive lock into hole in shaft until outer end of lock is $2\frac{5}{32}$ " below surface of boss on case.

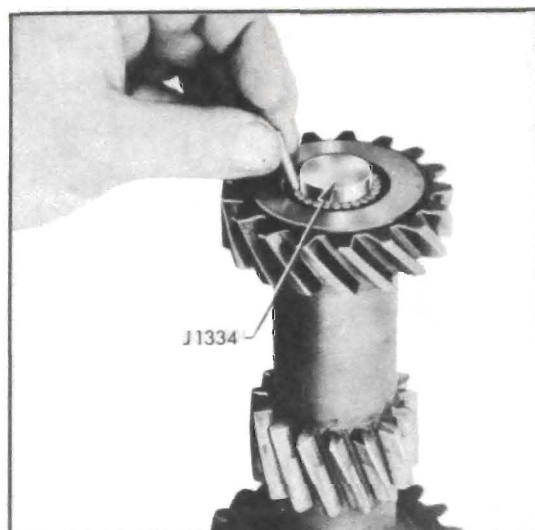

Figure 4-37—Installing Counter Gear Bearings with Loader J 1334

(7) *Counter Gear Bearings, Thrust Washer and Shaft.* Use Bearing Loader J-1334 when installing spacer, washer, and bearings in counter gear. See figure 4-37. Pack bearing rollers in white vaseline to hold them in place and make certain that all rollers are installed (25 in each bearing). Leave loader in gear until it is pushed out by the counter gear shaft during installation.

Install locking ball in counter gear shaft then install shaft through rear end of case, driving rear end of shaft slightly below face of case so that rear bearing retainer may be tightened against its gasket.

(8) *Main Shaft Snap Ring.* Use Snap Ring Replacer J 1267 to install the snap ring and avoid distorting ring. See figure 4-38.

(9) *Selector Lever and Shaft, Washers and Oil Seal.* Place spring washer, flat washer, and oil seal on shaft in the order named, with crowned side of spring washer against the flat washer. Apply Lubriplate to shaft before installation of assembled parts in transmission case.

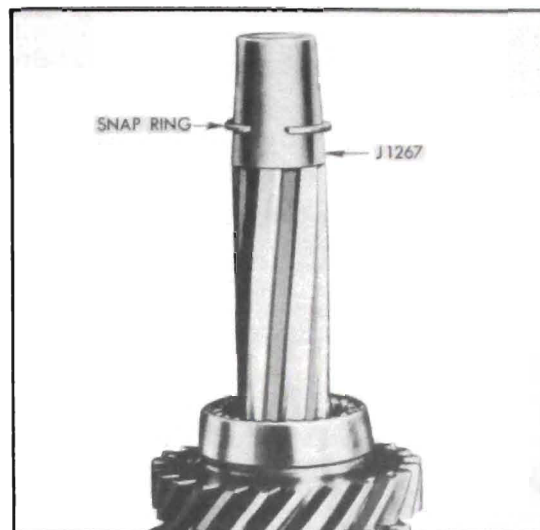

Figure 4-38—Snap Ring Replacer J 1267

(10) *Selector Shaft and Shifter Levers.* Coat oil seal with Lubriplate and install selector shaft through left side of transmission case to avoid damaging the oil seal. The long shifter lever goes on left side of case, and short shifter lever goes on right side. Install a new welsh plug in right side of case, sealing it with white lead or other compound. A welsh plug must also be installed in front side of case to seal opening for second and third shifter yoke shaft. Make certain that selector shaft slides freely after installation, otherwise hard selection of proper gear will result at control lever.

(11) *Shift Lever, Toggle Spring and Extension.* Hold shift lever in neutral position while installing and tightening attaching bolt and lock washer, to avoid damaging shifter levers on selector shaft. Install toggle spring and extension so that the extension passes underneath the selector shaft. Make sure that extension is not distorted so that it bears against the selector shaft.