

SECTION 10-E

CRANKING (STARTER) SYSTEM

CONTENTS OF SECTION 10-E

Paragraph	Subject	Page	Paragraph	Subject	Page
10-29	The Cranking (Starter) System	10-33	10-34	Voltage Test of Cranking System and Solenoid Switch . . .	10-40
10-30	Carburetor Starter Switch . . .	10-35	10-35	Trouble-Shooting Solenoid Switch (Starter) Relay . . .	10-41
10-31	Neutral Safety Switch and Back-Up Light Switch	10-37	10-36	Amperage Test of Solenoid and Pinion Clearance Check	10-41
10-32	Cranking Motor, Solenoid Switch, and Relay	10-38	10-37	Bench Test of Cranking Motor	10-42
10-33	Periodic Inspection of Cranking Motor	10-40	10-38	Cranking Motor Repairs—On Bench	10-43

10-29 THE CRANKING (STARTER) SYSTEM

a. General Description

The Buick cranking system permits the engine to be cranked by turning the ignition switch on and depressing the accelerator pedal. While accelerator pedal is depressed the cranking motor continues operation until the engine starts running on its own power, then the cranking motor circuit is automatically opened and the motor is disengaged from the flywheel ring gear.

The cranking system, shown schematically in figure 10-20, is composed of the following units:

1. *Battery and battery cables* (par. 10-14).
2. *Cranking motor*, including the drive assembly which engages the flywheel ring gear during cranking operation (par. 10-32).
3. *Cranking motor solenoid switch*, mounted on cranking motor, for shifting drive assembly and closing the motor circuit. During cranking the switch also connects the ignition coil directly to the battery, thereby bypassing the ignition coil resistance unit (par. 10-32).
4. *Solenoid switch relay*, mounted on left fender skirt, for operating the solenoid switch. (par. 10-32).
5. *Carburetor starter switch*, mounted on the carburetor and operated by the throttle shaft. This switch permits control of cranking system by the accelerator pedal (par. 10-30).
6. *Generator windings*, which are used for completing the vacuum switch and solenoid relay magnet coil circuit to ground.
7. *Charge indicator, ignition switch*, and necessary wiring to connect the various units.
8. *Neutral safety switch*, only on cars equipped with Dynaflo Drive. This switch is

connected in series with the solenoid switch relay to prevent cranking of engine except when the transmission control lever is in either the neutral (N) or parking (P) position.

b. Operation of Cranking System

CAUTION: *The radio should be turned off while starting the engine because certain radio parts may be damaged if cranking motor is operated with radio turned on.*

When the ignition switch is turned on and the accelerator pedal is depressed to open the throttle valve in carburetor, the throttle shaft actuates the carburetor starter switch to close the switch contacts. *On Dynaflo Drive cars, the transmission control lever must be in neutral (N) or parking (P) position so that neutral safety switch is also closed.*

Closing of the ignition, carburetor starter, and neutral safety switches permits battery current to flow through the magnet windings of the solenoid switch relay and through the field windings of the generator to ground. See figure 10-20. Flow of current through the relay windings magnetizes the core which pulls the relay armature down to close the relay contacts. Battery current then flows through the "pull in" and "hold in" coils of the solenoid, magnetizing the solenoid. The plunger is pulled into the solenoid so that it operates the shift lever to move the drive pinion into engagement with flywheel ring gear and then closes the solenoid switch contacts.

The closing of the solenoid switch contacts causes the motor to crank the engine and also cuts out the "pull-in" coil of the solenoid, the magnetic pull of the "hold-in" being sufficient to hold the pinion in mesh after the shifting has been performed. This reduces the current con-

sumed by the solenoid while the cranking motor is operating.

As soon as the engine starts running, the generator output voltage opposes the flow of current through the solenoid switch relay and generator windings, consequently the relay circuit ground connection is blocked and the circuit is opened. This demagnetizes the relay core and permits the relay contacts to open and break the solenoid circuit so that the solenoid is also demagnetized.

A return spring then actuates the shift lever to retract the solenoid plunger, which permits another spring to open the solenoid switch contacts. At the same time, the shift lever disengages the drive pinion from the flywheel ring gear.

Whenever the throttle is returned to idle position after the engine starts running, the carburetor starter switch contacts are separated and the solenoid switch relay circuit is opened

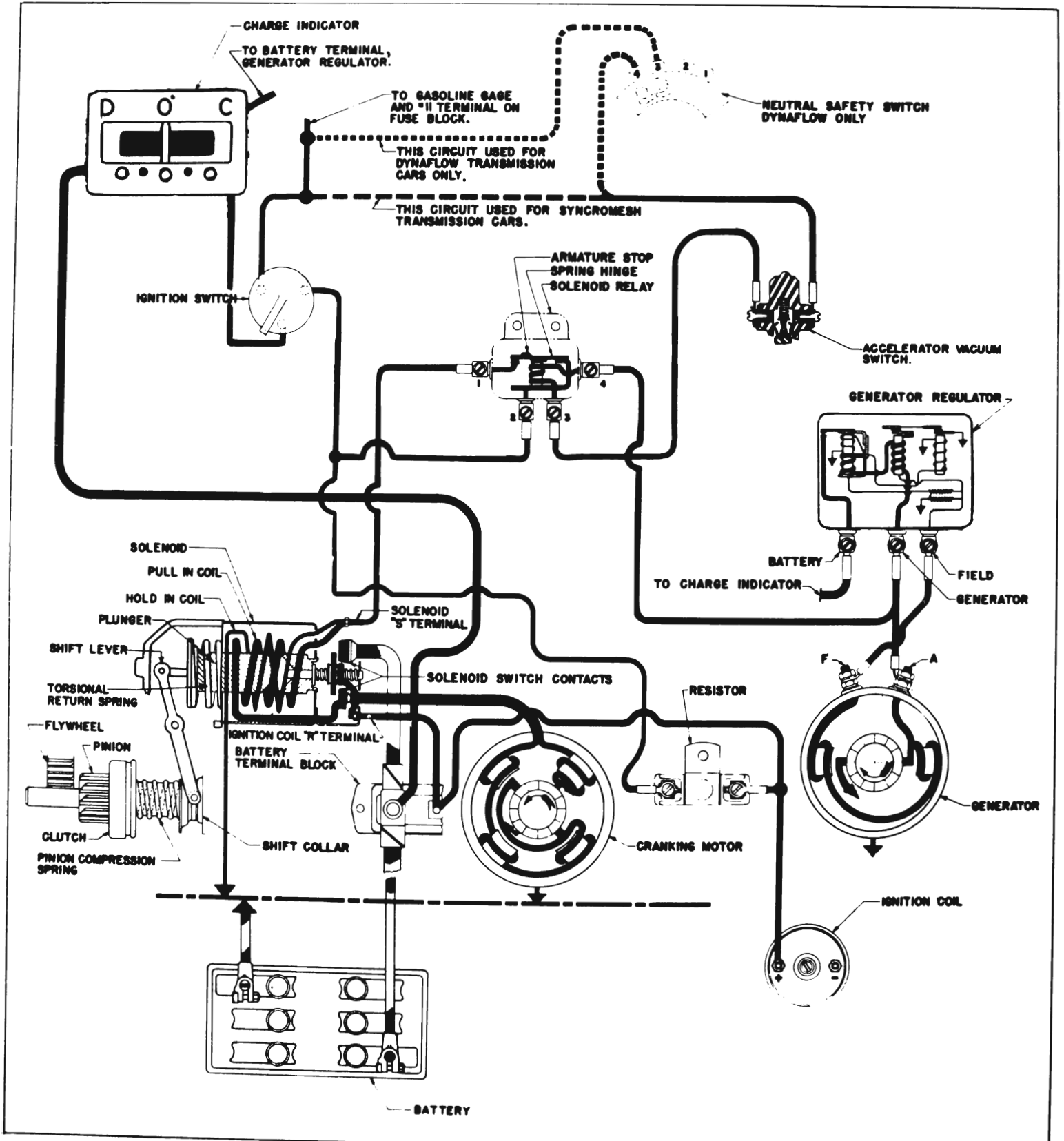

Figure 10-20—Cranking System Circuits

at this point. Manifold vacuum controls a lock out device in the switch which prevents the contacts from closing when the throttle is again opened to accelerate the engine. This lockout device is described in paragraph 10-30.

In cold weather, if the first explosions are too feeble to keep the engine running under its own power the generator output voltage will not be sufficient to block the solenoid switch relay circuit and permit the relay contacts to open. If the throttle is held open the cranking motor will continue in operation until the explosions are strong enough to keep the engine running at a speed where generator output voltage is high enough to block the relay circuit and cut out the cranking system.

While the engine is running, operation of the accelerator pedal will not bring the cranking motor into operation because of two separate and independent safety features: (1) Blocking effect of generator voltage on solenoid switch relay circuit. (2) Mechanical lockout of switch contacts in the carburetor starter switch.

10-30 CARBURETOR STARTER SWITCH

a. Description and Operation

The carburetor starter switch is built into the throttle body of the carburetor in position to be operated by the throttle shaft.

The switch consists of a special stainless steel ball, plunger, guide block, W-shaped contact spring, and return spring housed in a passage in

body flange which is closed by a terminal cap containing two contacts. When the engine is not running and throttle is closed, the ball rests on a lip on the lower end of switch plunger and bears against a flat spot on the throttle shaft. The plunger, guide block, and contact spring are held in a down position by the return spring so that the contact spring does not touch the contacts in terminal cap. See figure 10-21, view A.

When the accelerator is depressed with engine stopped and ignition switch turned on, the flat spot on throttle shaft acts as a cam to push the switch ball, plunger, guide block, and contact spring upward until the contact spring touches both contacts in terminal cap. This closes the solenoid relay switch circuit and puts the cranking system into operation. See figure 10-21, view B.

After the engine starts running and the throttle is returned to idle position, manifold vacuum causes the ball to move upward against a seat in the throttle body and the switch return spring pushes the contact spring and plunger down to separate the switch contacts, thereby opening the solenoid switch relay circuit at this point. See figure 10-21, view C. As long as the engine continues running the switch ball is held against its seat due to manifold vacuum; therefore movement of the throttle shaft cannot be transmitted to the plunger to close the switch contacts. When the engine stops so that manifold vacuum ceases, the ball drops down to the starting position between throttle shaft and plunger.

It is very important that the switch contact

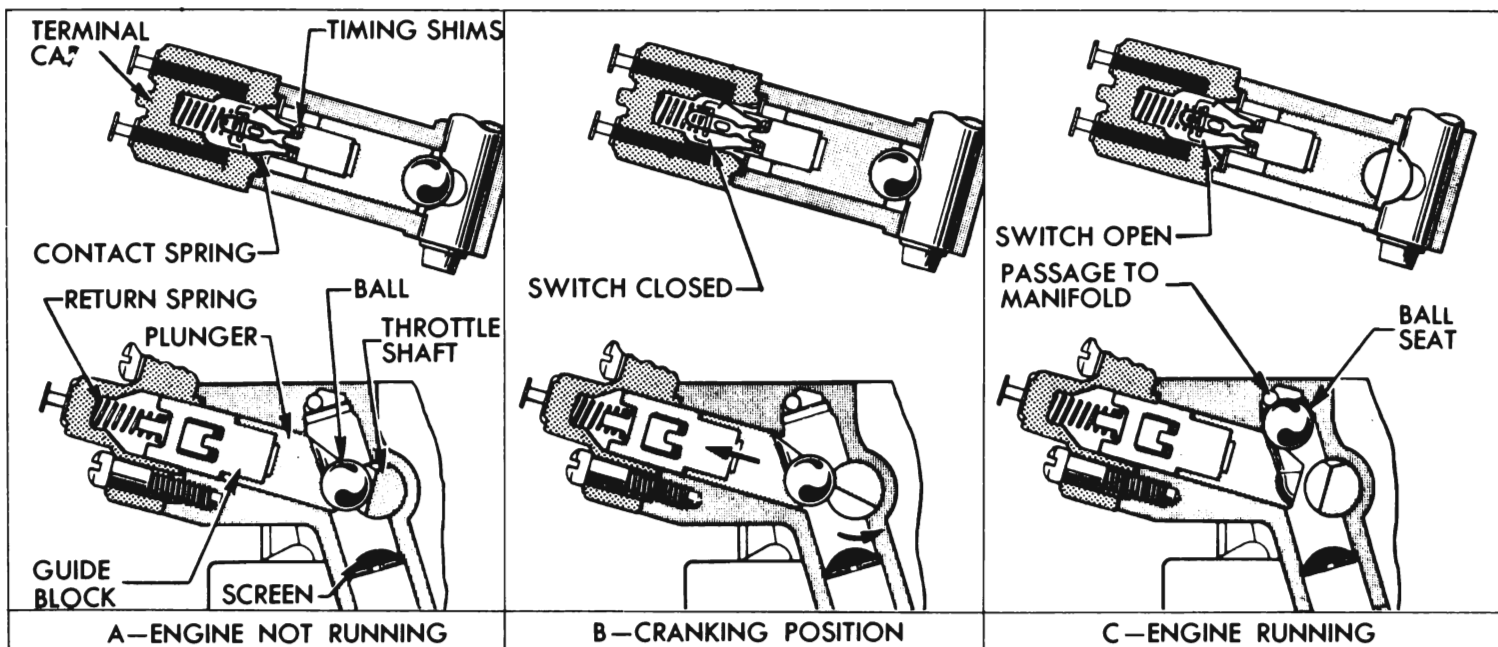

Figure 10-21—Carburetor Starter Switch Operation

is made at a specific throttle opening, to assure proper starting conditions. If the switch makes contact too early the throttle will not be opened sufficient to give a good cold start. If the switch makes contact too late the throttle will be opened too far, which may cause gear clash as well as hard starting due to unloading of carburetor choke by the throttle mechanism. The correct throttle opening for switch contact is 35° to 50° on 2-barrel carburetors, and 25° to 40° on 4-barrel carburetors. Check switch timing as described below (subpar. *c* or *d*).

b. Cleaning and Lubricating Switch

Switch timing may be changed without removing carburetor from engine; however, if switch is dirty the carburetor should be removed so that switch passages can be properly cleaned.

1. Disconnect wires from terminals. Hold down on switch terminal cap while removing hold down clip. Remove terminal cap and return spring, then lift out switch guide block with contact spring and shims. Do not lose timing shims and the spring washer on contact spring. See figure 10-22.

2. Remove plunger and steel ball from carburetor throttle body.

3. Wash all metal parts in Bendix Metalclene, or its equivalent, and wipe dry. Clean out passages in throttle body. Do not soak terminal cap and guide block in cleaning solution, but wipe with a clean cloth.

4. Inspect ball, plunger, and cylinder in throttle body to make sure that all are clean and smooth. Check terminal cap for cracks. Switch contact surfaces must be smooth and free of corrosion. If screen is damaged or clogged so that it cannot be cleaned it should be replaced.

5. Check condition of contact spring and replace it if burned or otherwise damaged. The free width of spring across the points, with return spring washer in place is $\frac{7}{16}'' + \frac{1}{32}'' - 0$.

6. The free length of switch return spring is $\frac{11}{16}''$ to $\frac{3}{4}''$. Replace a weak or distorted spring; do not stretch or alter spring as switch operation will be affected.

7. The contact spring rests on a number of square brass shims which control the switch timing. If switch timing was found to be too early (subpar. *b*, *d*, or *e*), reduce the total thickness of these shims. If timing was too late, increase total thickness of shims. These shims are furnished in thicknesses of .006'' and .018''

8. Before installing parts, the contact surfaces in terminal cap should be given a light coating of Standard Oil Arctic Cup Grease No. 3. If this lubricant is not available petroleum jelly may be used. Work lubricant into a piece of clean cloth and lightly swab the inside of terminal cap. **CAUTION:** *Do not use ordinary lubricants as poor switch contact will be obtained in cold weather. Do not apply lubricant to the ball or plunger.*

9. Place plunger in position with the groove up so that the ball rests on lip at inner end of plunger. See figure 10-22. If the plunger is installed with groove down, the ball will be prevented from rising into the ball passage when the engine starts. As a result, the switch will close each time the throttle is opened, causing gear clash at low speeds when the generator is not producing sufficient voltage to open the solenoid relay. If generator should be inoperative, gear clashing would occur at all speeds.

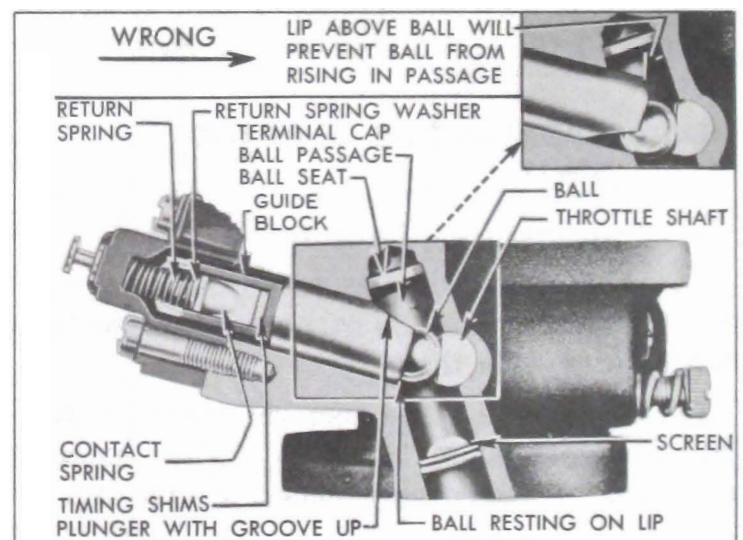

Figure 10-22—Assembly of Carburetor Starter Switch

10. Make sure that all timing washers, contact spring, and the return spring washer are in proper position before installing the return spring and terminal cap. Make sure that terminal cap is properly seated. See figure 10-22.

11. After switch is assembled, check the timing as described below (subpar. *c* or *d*), and change shims as required until proper timing is obtained.

c. Checking Switch Timing on Bench (All Cars)

1. Connect a 12-volt battery and test lamp across switch terminals so that lamp will light when switch makes contact.

2. Block choke valve open so that fast idle cam is at slow idle position.

3. While holding carburetor in normal up-right position, insert a $\frac{1}{4}$ " drill between wall of throttle body and lower edge of one primary throttle valve, at the center. With valve closed against the drill, the switch should make contact and light the test lamp.

4. Remove the $\frac{1}{4}$ " drill and insert a $\frac{7}{64}$ " drill in same position. With valve closed against drill, the switch should be open so that test lamp does not light.

5. If switch does not operate within the limits specified, retune it by changing shims as required (subpar. b, above).

d. Checking Switch Timing on Car (Dynaflow Only)

With the carburetor installed on the engine, the following procedure may be used (on Dynaflow equipped cars) to determine whether the carburetor starter switch timing is within proper limits. On synchromesh equipped cars, the carburetor must be removed; the switch timing may then be checked according to the procedure in subparagraph c above.

1. Make certain that transmission is in Park position and that parking brake is applied.

2. Back off throttle stop screw, rotate fast idle cam to slow idle position if necessary, and fully close throttle valve. Make certain that dash pot does not prevent full closing of throttle valve.

3. With throttle valve fully closed, measure distance from diaphragm flange of dash pot to near edge of dash pot arm on throttle lever. See figure 10-23.

4. With ignition turned on, slowly open throt-

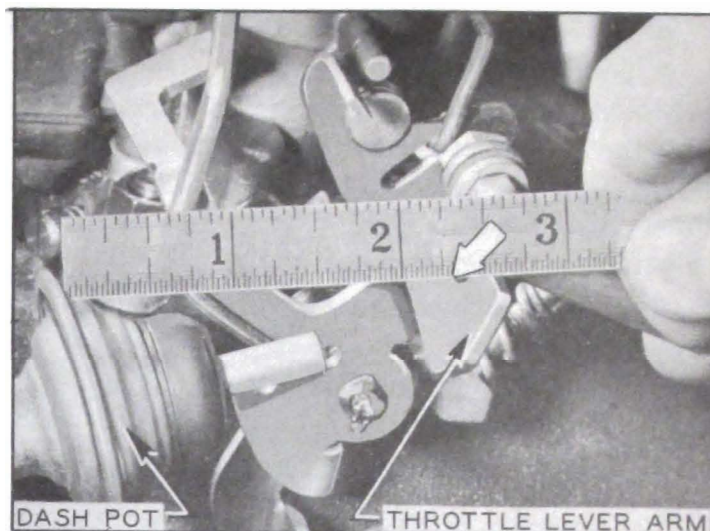

Figure 10-24—Checking Switch Timing on Car—Step Two

tle while holding scale in position against flange of dash pot. When cranking motor is energized, note distance from flange of dash pot to near edge of dash pot arm. See figure 10-24.

5. Subtract the two measurements. If switch is properly timed, the difference should be as follows:

Carburetor	Difference
Carter—2 Bbl.	$1\frac{1}{16}$ to $1\frac{5}{8}$
Carter—4 Bbl.	$1\frac{3}{16}$ to $1\frac{5}{16}$
Stromberg—2 Bbl.	1 to $1\frac{7}{16}$
Rochester—4 Bbl.	$1\frac{3}{16}$ to $1\frac{3}{8}$

6. If necessary, retune switch by changing the number of timing shims as described in subparagraph b above. When switch is correctly timed set engine idle speed at 485 RPM on regular cars or 550 RPM on air conditioned cars. Also make sure that throttle linkage and dash pot are correctly adjusted (par. 3-9).

10-31 NEUTRAL SAFETY SWITCH AND BACK-UP LIGHT SWITCH

On all Dynaflow cars, a combination neutral safety and back-up light switch is mounted on the steering column jacket under the instrument panel. This switch is actuated by a lever on the transmission control shaft which projects through a slot in the jacket.

All synchromesh cars with the back-up light option have a back-up light switch mounted on the steering column jacket. This switch is actuated by a pin on the switch itself which projects through a slot into the jacket. A short arm on the transmission control shaft actuates this switch pin while in the reverse position only.

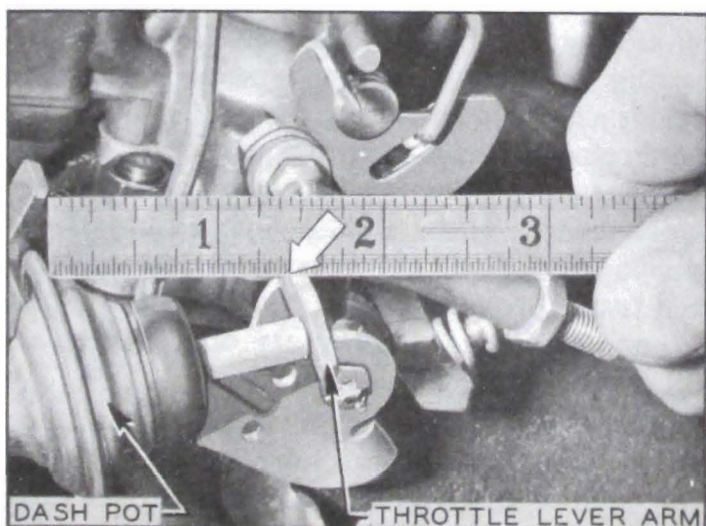

Figure 10-23—Checking Switch Timing on Car—Step One

a. Neutral Safety Switch Timing Adjustment (All Dynaflow)

Slotted mounting screw holes permit side-wise movement of the switch for proper timing. When the neutral safety switch is correctly timed, the back-up light portion of the switch is properly timed automatically.

Check and adjust neutral safety switch timing as follows:

1. Check Dynaflow shift control linkage and adjust if necessary (par. 5-12).
2. Place shift control lever in Neutral position.
3. Insert a $\frac{3}{32}$ " drill or a piece of $\frac{3}{32}$ " drill rod through gauging hole in operating lever and through gauging hole in switch body. **CAUTION:** *Be careful not to cause shift control lever to move out of neutral position. See figure 10-25.*

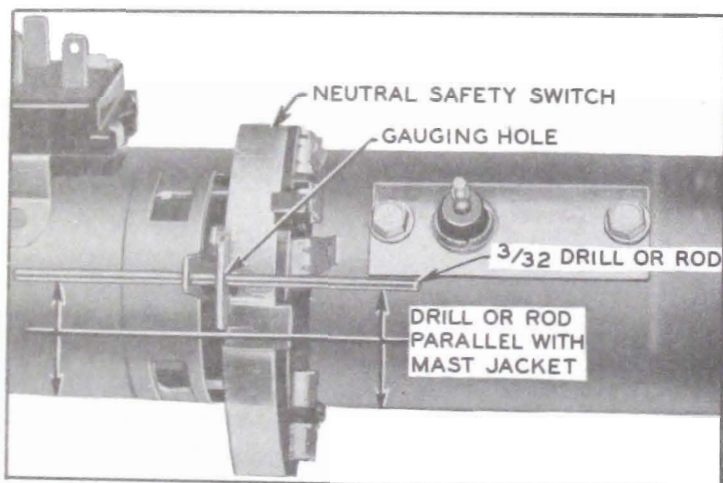

Figure 10-25—Checking Neutral Safety Switch Timing

4. If gauging drill or drill rod is now parallel with center line of steering column jacket, neutral safety switch timing is OK. If gauging drill will not go through holes or is *not* parallel, loosen two switch mounting screws and move switch sidewise until gauge is parallel. Then retighten screws.

5. To recheck adjustment, turn on ignition switch, place shift control lever in reverse, and make sure back-up lights are lit. Set parking brake, place shift lever in Neutral and make sure engine will start. Then place shift lever in Park and try starting engine again.

b. Back-Up Light Switch Adjustment (Synchromesh Only)

Slotted mounting screw holes permit movement of the switch up and down the steering column jacket for proper locating.

1. Check synchromesh shift control linkage and adjust if necessary (par. 4-11).

2. Place shift control lever in second gear position.

3. Loosen two switch mounting screws and move switch up steering column jacket until switch pin contacts side of arm on transmission control shaft.

4. Scribe jacket at top edge of switch, then move switch down jacket $\frac{1}{16}$ inch from scribe mark and tighten screws. This provides a clearance so that switch will not be actuated in second gear; however, in reverse gear, arm on transmission control shaft will contact switch pin squarely.

5. To recheck adjustment, turn on ignition switch and shift into second gear. Back-up lights should not light. Then shift into reverse gear and make sure back-up lights are lit.

10-32 CRANKING MOTOR, SOLENOID SWITCH, AND RELAY

The cranking motor assembly consists of a motor, drive assembly, shift lever, and solenoid switch. See figure 10-26. It is mounted on the flywheel upper housing on the left side of engine.

a. Cranking Motor, Drive and Shift Lever

The cranking motor is an enclosed shift lever type, having an extruded frame, four poles and a compound field. The drive end housing is extended to enclose the entire shift lever mechanism and plunger to protect them from road dirt, icing conditions, and splash. The solenoid is flange mounted onto the drive end housing and is sealed to the drive housing by a sealing compound. The shift lever return spring is a compression type and is located inside the solenoid case. Three field coils are connected in series from the solenoid motor terminal to the insulated brushes, and one shunt coil is connected from the solenoid motor terminal to ground. A rubber grommet assembled in the frame around the leads insulates them from grounding and also prevents dirt, water, and oil from entering the motor.

The armature shaft is supported at both ends in graphite bronze bushings pressed into the commutator end frame and the drive housing. Neither of these bearings require lubrication except during assembly.

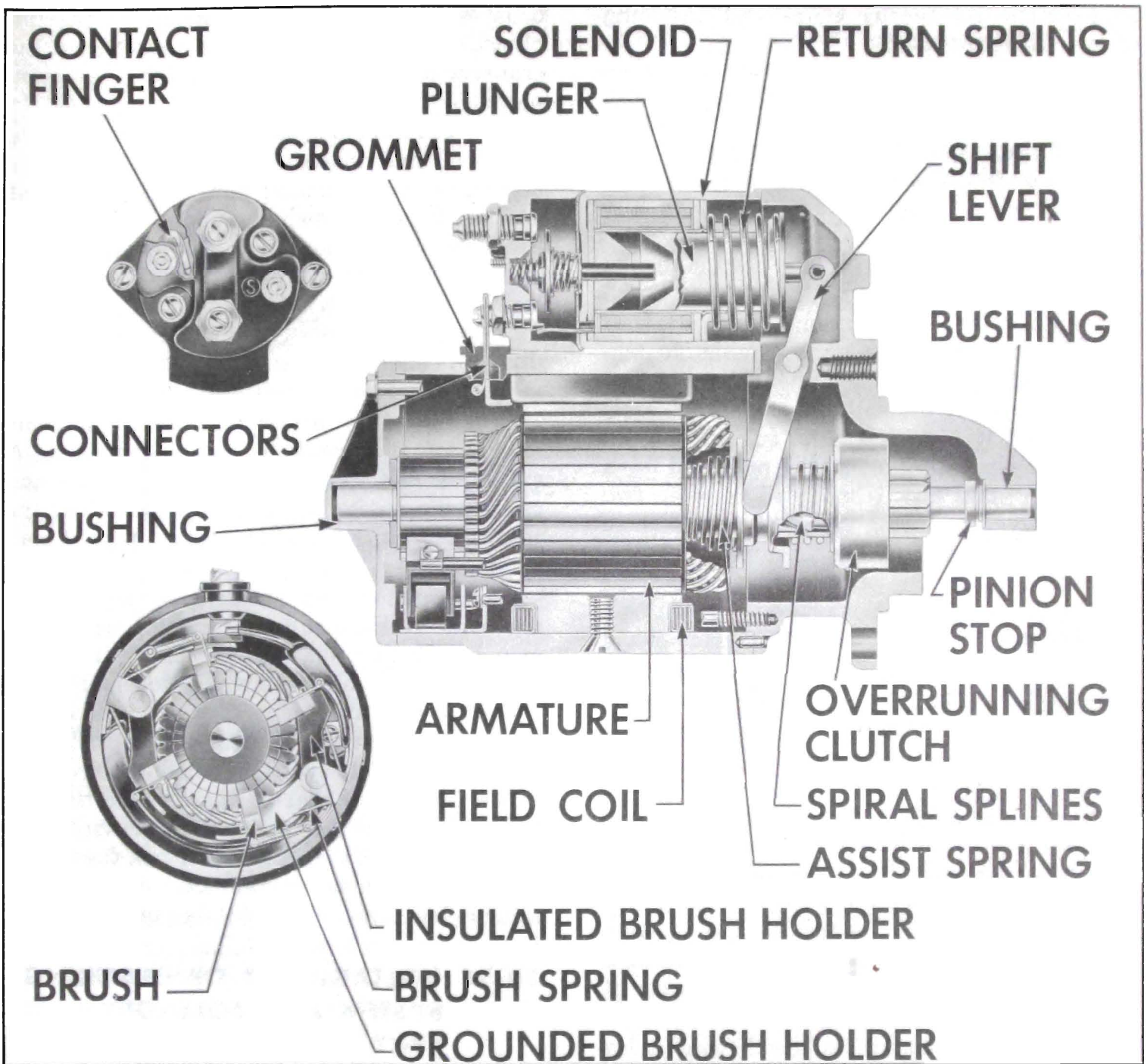

Figure 10-26—Cranking Motor—Sectional View

The four brushes are supported by brush holders mounted on the field frame. Two opposing brushes are connected to the field coils. The field coils are held in place by the pole shoes which are attached to the field by large screws. The field coils are connected to an insulated connecting link in the field frame, through which current is supplied to the motor.

The drive assembly is mounted on the motor armature shaft and keyed to it by helical splines so that it can be moved endwise on the shaft by the solenoid operated shift lever. It transmits cranking torque to the flywheel ring gear, but its overrunning clutch allows the drive pinion to rotate freely with reference to the armature

shaft when the engine begins to operate, thus preventing the armature from being driven at excessive speed by the engine.

The drive assembly pinion is moved into engagement with flywheel ring gear by action of the solenoid upon the shift lever, which engages the shift collar of drive assembly. The shift collar moves the drive assembly by pushing on the clutch spring, which serves as a cushion in case the pinion and gear teeth butt instead of meshing. The helical splines assist in obtaining proper pinion engagement. The drive pinion is pulled out of engagement, after engine starts, by action of the shift lever return spring. The shift lever is connected to the sole-

noid switch plunger by a link and adjusting screw. See figure 10-26.

b. Solenoid Switch and Relay

The solenoid switch not only closes the circuit between the battery and the cranking motor to produce cranking action, but it also operates the shift lever to move the drive pinion into engagement with the flywheel ring gear.

The solenoid section of the switch has a plunger and two windings, the "pull-in" winding and the "hold-in" winding. Together, they provide sufficient magnetic attraction to pull the solenoid plunger into the solenoid. The plunger actuates the shift lever and drive assembly and it also closes the solenoid switch contacts by pressing against a push rod upon which a contact disk is mounted between two coil springs. One spring serves as a cushion to insure firm contact of the disk with two stationary contacts. The other spring pushes the disk away from the stationary contacts to break the circuit when the solenoid is demagnetized after the engine starts. One stationary contact is connected to the battery positive cable and the other is connected to the motor windings through a connector or bus bar. See figure 10-26.

The solenoid switch has an additional small terminal which touches the switch contact disk only when the solenoid is energized. A lead connects this terminal to the battery side of the ignition coil, thereby by-passing the ignition coil resistance unit during cranking operation and making full battery voltage available at the coil.

The separately mounted solenoid switch relay is an electrical switch which closes the circuit between the battery and the solenoid windings when cranking action is desired, and opens the circuit when the engine starts running. The relay has one winding surrounding a core which, when magnetized by current flowing through the winding, attracts a flat steel armature. The armature has a contact point which makes contact with a stationary point to close the circuit.

Operation of the solenoid switch and relay, as well as the entire cranking system, is described in paragraph 10-29.

10-33 PERIODIC INSPECTION OF CRANKING MOTOR

No periodic lubrication of the cranking motor or solenoid is required. The cranking motor and

brushes cannot be inspected without disassembling the unit so no service is required on the cranking motor and solenoid between inspection periods.

As a general rule, the cranking motor should be tested and inspected every 5000 miles to determine its condition; however, the type of service in which some cranking motors are used may make more frequent inspection advisable. Frequent starts, as in city operation, excessively long cranking periods caused by hard-starting engine conditions, excessively dirty or moist operating conditions, all will make more frequent inspection advisable.

Cranking motor action is indicative, to some extent, of the cranking motor condition. A cranking motor that responds readily and cranks the engine at normal speed when the control circuit is closed is usually in good condition.

Check motor and solenoid switch attaching bolts to make sure these units are solidly mounted. Inspect and manually check all wiring connections at solenoid switch, solenoid relay, generator regulator, generator, accelerator vacuum switch, ignition switch, charge indicator, and neutral safety switch (Dynaflow Drive cars only). Make sure that all these connections in the cranking motor and control circuits are clean and tight. It is advisable to test the cranking circuit to make certain that excessive resistance does not exist. See paragraph 10-34.

10-34 VOLTAGE TEST OF CRANKING SYSTEM AND SOLENOID SWITCH

The voltage across the cranking motor and switch while cranking the engine gives a good indication of any excessive resistance. *NOTE: Engine must be at normal operating temperature when test is made.*

1. Inspect battery and cables (par. 10-15) to make certain that battery has ample capacity for cranking and ignition.
2. Connect jumper wire to distributor terminal of coil and to ground on engine, so that engine can be cranked without firing.
3. Connect voltmeter positive (+) lead to the motor terminal on solenoid switch; connect voltmeter negative (-) lead to ground on engine. See figure 10-27.
4. Turn ignition switch on, crank engine and take voltmeter reading as quickly as pos-

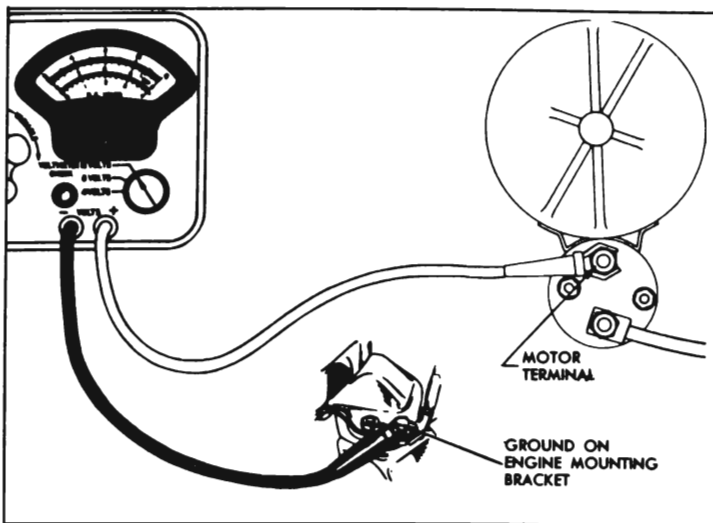

Figure 10-27—Cranking Voltage Test Connections

sible. If cranking motor turns engine at normal cranking speed with voltmeter reading 9 or more volts, the motor and switch are satisfactory. If cranking speed is below normal and voltmeter reading is 9 or greater, the cranking motor is defective.

CAUTION: Do not operate cranking motor more than 30 seconds at a time without pausing to allow motor to cool for at least two minutes; otherwise, overheating and damage to motor may result.

5. If cranking motor turns engine at low rate of speed with voltmeter reading less than 9 volts, test solenoid switch contacts as follows.

6. With voltmeter switch turned to any scale above 12 volts, connect voltmeter negative (–) lead to the motor terminal of solenoid switch, and connect positive (+) lead to battery terminal of switch. See figure 10-28.

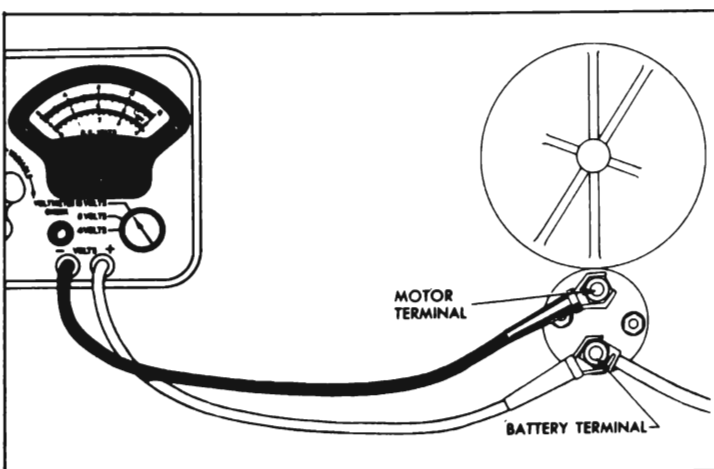

Figure 10-28—Solenoid Switch Contact Test Connections

7. Turn ignition switch on and crank engine. Immediately turn voltmeter switch to low scale and take reading as quickly as possible, then turn switch back to higher scale and stop engine.

The voltmeter will read not more than $\frac{1}{10}$ volt if switch contacts are satisfactory. If voltmeter reads more than $\frac{1}{10}$ volt, switch should be repaired or replaced.

10-35 TROUBLE-SHOOTING SOLENOID SWITCH (STARTER) RELAY

There are two basic troubles which may be caused by a defective starter relay. If the engine will not crank at all, this trouble may be caused by the relay points not making contact. Or, if the engine cranks, but will not stop cranking when the accelerator pedal is released, this trouble may be caused by the relay points sticking.

To check for a defective starter relay, follow the procedure in subparagraph a or b below:

a. Engine Will Not Crank

1. Make sure that conditions are right for cranking; that is, ignition is turned on, transmission is in Parking or Neutral, and accelerator pedal is depressed.

2. Try eliminating starter relay as cause of trouble by connecting a jumper from battery cable at terminal block to relay terminal (No. 3) at which small pink wire is connected. See figure 10-20. If engine now cranks, relay is OK, but starter relay control circuit is not functioning. See paragraph 10-9.

3. If engine still does not crank, connect a heavy jumper between large pink wire (No. 2) and large black wire (No. 1) at relay. If engine now cranks, starter relay is defective and must be replaced. See figure 10-20.

4. If engine still does not crank, relay is OK, but cranking motor or solenoid is not functioning. See paragraphs 10-34, 36 and 37.

b. Engine Will Not Stop Cranking

1. Disconnect small pink wire from terminal (No. 3) of relay. See figure 10-24. If engine now stops cranking, relay is OK, but starter relay control circuit is not functioning properly. See paragraph 10-9.

2. If engine still will not stop cranking, starter relay is defective and must be replaced.

10-36 AMPERAGE TEST OF SOLENOID AND PINION CLEARANCE CHECK

a. Testing Solenoid Switch Windings

The solenoid switch windings may be tested with the switch disconnected from the cranking

motor. Two tests may be made to determine:

(1) Current draw of both windings in parallel.

(2) Current draw of hold-in winding alone.

1. Remove screw from solenoid motor terminal and bend field leads slightly until clear of terminal. Then ground solenoid motor terminal with a heavy jumper wire. See figure 10-30.

2. Connect a 12-volt battery, a variable resistance, and an ammeter of 100 amperes capacity in series with solenoid "S" terminal. See figure 10-26 for location of "S" terminal. Connect a heavy jumper wire from solenoid base to ground post of battery.

3. Connect a voltmeter between base of solenoid and small solenoid "S" terminal.

4. Slowly adjust resistance until voltmeter reads 10 volts and note ammeter reading. This shows current draw of both windings in parallel, and should be 40 to 45 amperes at 10 volts, *with solenoid at room temperature*. See figure 10-20 for a diagram of solenoid circuits.

5. Remove jumper wire from solenoid motor terminal and readjust resistance until voltmeter reads 10 volts, then note ammeter reading. This shows current draw of hold-in winding alone, and should be 10 to 12 amperes at 10 volts, *with solenoid at room temperature*.

6. If solenoid windings do not test within specifications given, solenoid switch assembly should be replaced.

b. Checking Pinion Clearance

Whenever the cranking motor is disassembled and reassembled, the pinion clearance should be checked. This is to make sure that proper clearance exists between the pinion and the pinion stop retainer when pinion is in cranking position. Lack of clearance would prevent solenoid starter switch from closing properly; too much clearance would cause improper pinion engagement in ring gear.

1. Connect a source of approximately 6 volts (3 battery cells or a 6 volt battery) between the solenoid "S" terminal and ground. **CAUTION:** *Do not connect the voltage source to the "R" ignition coil terminal. Do not use more than 6 volts or the motor will operate. As a further precaution to prevent motoring, connect a heavy jumper wire from the solenoid motor terminal to ground.*

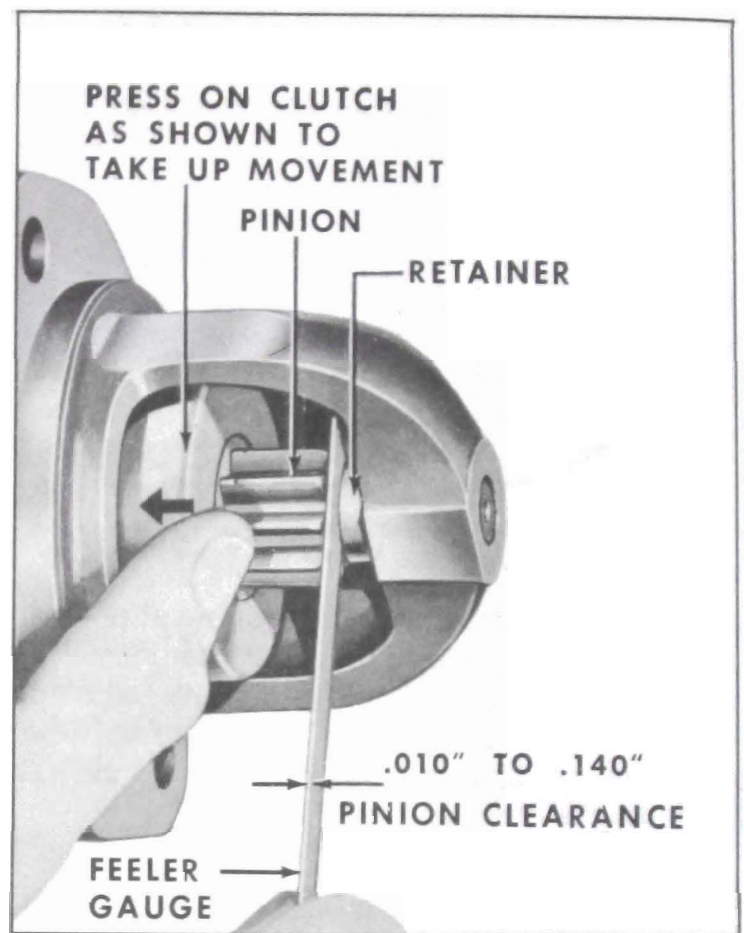

Figure 10-29—Checking Pinion Clearance

2. After energizing the solenoid, push the pinion away from the stop retainer as far as possible and use feeler gauge to check clearance between pinion and retainer. See figure 10-29.

3. If clearance is not between .010" and .140", it indicates excessive wear of solenoid linkage, shift lever mechanism, or improper assembly of these parts. **NOTE:** *Pinion clearance cannot be adjusted. If clearance is not correct, motor must be disassembled and checked for the above mentioned defects. Any defective parts must be replaced.*

10-37 BENCH TEST OF CRANKING MOTOR

To obtain full performance data on a cranking motor, or to determine the cause of abnormal operation, the motor should be removed from the engine and be submitted to a no-load and a torque test with equipment designed for such tests. Test specifications are given under Electrical Specifications in paragraph 10-3.

(a) *No-load Test.* Connect the cranking motor in series with a 12-volt battery and an ammeter capable of indicating several hundred amperes. If an RPM indicator is available, set it up to read armature RPM.

(b) *Torque Test.* Torque testing equipment should be used to determine if the motor will develop rated torque. A high current-carrying variable resistance should be connected into the circuit so that the specified voltage at the cranking motor may be obtained, since a small variation in the voltage will produce a marked difference in the torque development.

Rated torque, current draw and no-load speed indicates normal condition of cranking motor. Abnormal conditions may be indicated by one of the following:

1. *Low free speed and high current draw with low developed torque* may result from:

(a) Tight, dirty, or worn bearings, bent armature shaft or loose field pole screws which would allow the armature to drag.

(b) Shorted armature. Check armature further on growler (par. 10-25).

(c) A grounded armature or field. NOTE: *Remove commutator end frame and disconnect shunt field (small wire) from insulated motor terminal before checking for grounds.*

Check for grounds by raising the grounded brushes and insulating them from the commutator with cardboard, and then checking with a test lamp between the insulated terminal and the frame. If lamp lights, raise other brushes from commutator and check fields and commutator separately to determine whether it is the fields or armature that is grounded.

2. *Failure to operate with high current draw* may result from:

(a) A direct ground in the terminal or fields.

(b) Frozen shaft bearings which prevent the armature from turning.

3. *Failure to operate with no current draw* may result from:

(a) Open field circuit. Disconnect shunt field, item 1 (C) above, then inspect internal connections and trace circuit with test lamp.

(b) Open armature coils. Inspect the commutator for badly burned bars.

(c) Broken or weakened brush springs, worn brushes, high mica on the commutator, or other causes which would prevent good contact between the brushes and commutator. Any of these conditions will cause burned commutator bars.

4. *Low no-load speed with low torque and low current draw* indicates:

(a) An open field winding. Disconnect shunt field, item 1 (C) above, raise and insulate ungrounded brushes from commutator and check field with test lamp.

(b) High internal resistance due to poor connections, defective leads, dirty commutator and causes listed under item 3 (c).

5. *High free speed with low developed torque and high current draw* indicates shorted fields. There is no easy way to detect shorted fields, since the field resistance is already low. If shorted fields are suspected, replace the fields and check for improvement in performance.

10-38 CRANKING MOTOR REPAIRS— ON BENCH

a. Disassembly, Cleaning and Inspection

When it is necessary to disassemble cranking motor for any reason, make a complete clean-up and inspection to make sure all parts are in satisfactory condition. See figure 10-26 for identification of parts.

1. Remove field lead connecting screw from motor terminal on solenoid.

2. Remove two thru bolts and remove commutator end frame and field frame assembly.

3. Pull out brush holder pivot pin and remove the two brush holders and the spring as a group. Remove screws attaching brushes and leads to holders.

4. Remove armature and drive assembly from drive housing. Remove thrust collar from pinion end of armature shaft, and remove leather thrust washer from opposite end of shaft.

5. To remove drive assembly from armature, place a metal cylinder of proper size ($\frac{1}{2}$ " pipe coupling will do) over end of shaft to bear against the pinion stop retainer. Tap retainer toward armature to uncover snap ring. See figure 10-30. Remove snap ring from groove in shaft, then slide retainer and pinion drive assembly from shaft. Remove assist spring.

6. Remove two screws holding solenoid to drive housing and remove solenoid. Remove small nut and insulating washer from the solenoid "S" terminal. Remove large nut and insulating washer from the solenoid battery terminal. See figure 10-26. Then remove two screws that attach switch cover to solenoid

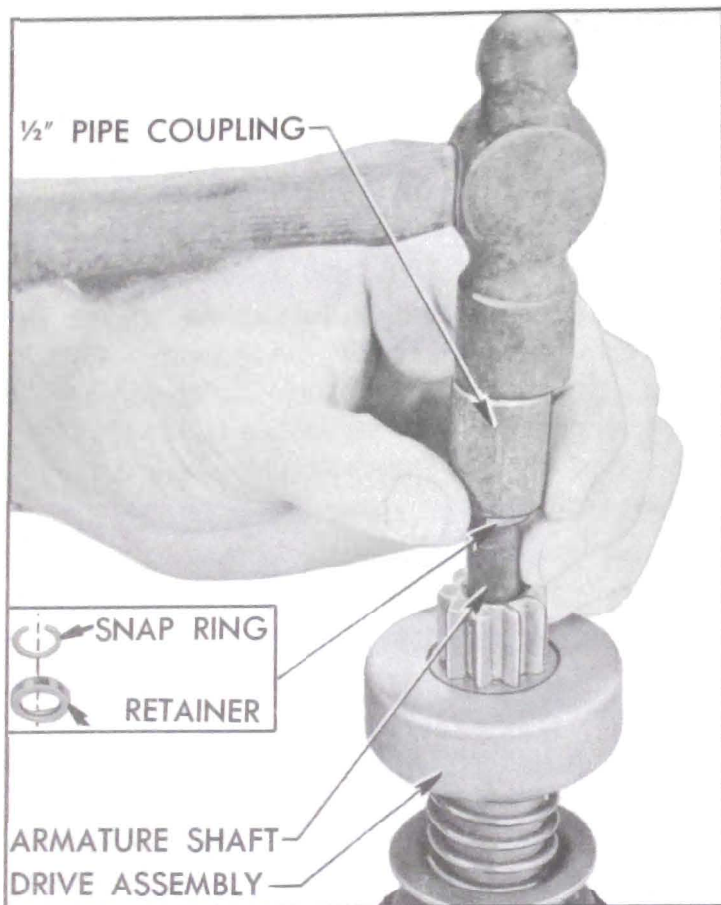

Figure 10-30—Removing Pinion Stop Retainer and Snap Ring

and remove cover for inspection of switch parts.

7. Remove shift lever fulcrum bolt and remove shift lever, plunger and return spring.

8. Clean all parts by wiping with clean cloths. The armature, field coils, and drive assembly must not be cleaned by any degreasing or high temperature method. This might damage insulation so that a short or ground would subsequently develop, and will remove lubricant originally packed in the overrunning clutch so that clutch would soon be ruined.

9. Carefully inspect all parts for wear or damage and make necessary repairs or replace unserviceable parts. Any soldering must be done with rosin flux; *never use acid flux on electrical connections.*

10. Test armature and make necessary repairs or turn commutator if required, following the same procedure as specified for generator in paragraph 10-25.

b. Assembly of Cranking Motor

1. Lubricate shift lever linkage and install in drive housing. **CAUTION:** *Never lubricate solenoid plunger or plunger cylinder.*

2. Assemble solenoid by reversing the disassembly procedure. Install return spring. Apply sealing compound on both sides of solenoid flange where it extends between drive housing and field frame. Then install solenoid.

3. Lubricate armature shaft with light engine oil. Install assist spring; then install drive assembly with pinion outward.

4. Slide pinion stop retainer down over shaft with recessed side outward.

5. Place a new snap ring on drive end of shaft and hold it in place with a hard wood block. Strike block with hammer to force snap ring over end of shaft, then slide the ring down into groove in shaft. See figure 10-31, view A.

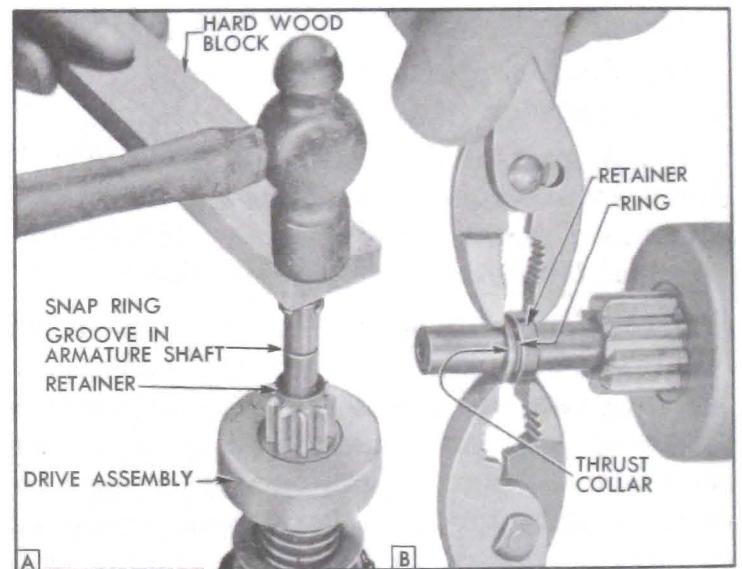

Figure 10-31—Pinion Stop Retainer and Snap Ring Installation

6. Place thrust collar on shaft with shoulder next to snap ring, and move the retainer into contact with ring. Using pliers on opposite sides of shaft squeeze retainer and thrust collar together until snap ring is forced into the retainer. See figure 10-31, view B.

7. Lubricate drive housing bushing with light engine oil and install armature and drive assembly in housing.

8. Continue with assembly of cranking motor by reversing disassembly procedure. If field coils were removed from field frame, use care in tightening pole shoe screws to avoid distortion of parts and make sure that screws are securely tightened.

9. Position field frame assembly over armature assembly so that dowel pin engages hole in drive housing. Use care to prevent damage to brushes and brush holders. Make sure that brushes are properly seated on commutator.

10. Before installation of commutator end frame, attach a spring scale at each brush and check the pull required to just lift brush off commutator. Brush spring tension should be 40 to 70 ounces.

11. Install leather thrust washer on commutator end of armature assembly. Lubricate bushing in commutator end frame with light

engine oil and install end frame.

12. Install thru bolts and tighten securely. Connect field leads to motor terminal of solenoid with connecting screw.

13. Test solenoid switch and check pinion clearance as described in paragraph 10-36. If a reliable starter tester is available, test motor as described in paragraph 10-37.