

# GROUP 1

## LUBRICARE AND BEARING SERVICE

### SECTIONS IN GROUP 1

Section	Subject	Page	Section	Subject	Page
1-A	Lubricare Instructions.....	1-1	1-B	Bearing Service.....	1-12

### SECTION 1-A

## LUBRICARE INSTRUCTIONS

### CONTENTS OF SECTION 1-A

Paragraph	Subject	Page	Paragraph	Subject	Page
1-1	Every 1000 Miles—Lubricare..	1-1	1-5	Lubricare as Required or When Accessible.....	1- 8
1-2	Every 5000 Miles—Lubricare..	1-5	1-6	Engine Oil Recommendations..	1-10
1-3	Every 10,000 Miles—Lubricare	1-7	1-7	Rear Axle Lubricant Recommendations.....	1-11
1-4	Every 25,000 Miles—Automatic Transmission.....	1-7			

### 1-1 EVERY 1000 MILES—LUBRICARE

1. *Engine.* Check engine oil level only after engine has been stopped for at least three to five minutes to allow oil to drain down.

The oil level should be maintained between the "FULL" and "ADD" marks on gauge rod; each space between marks represents 1 quart. Do not fill above the "FULL" mark. See figure 1-5.

See paragraph 1-6 for engine oil recommendations and when to change oil.

2. *Front Suspension, Steering Linkage, Clutch and Rear Propeller Shaft Lubrication Fittings.* Wipe dirt from lubrication fittings, then apply a good grade of water resistant chassis lubricant, under pressure, at the following points (fig. 1-2) :

- Upper Control Arm Shafts (4 fittings)
- Lower Control Arm Shafts (4 fittings)
- Upper Ball Joints (2 fittings)
- Lower Ball Joints (2 fittings)
- Tie Rod Ends (2), Intermediate Rod (2), and Idler Arm Support (1)
- Clutch Release Equalizer (1)
- Rear Propeller Shaft Spline (1) See figure 1-4.

3. *Oil Filter.* Change original oil filter at first 1,000 miles, then change it each 4,000 mile interval thereafter.

Screw filter off filter base and discard. Wipe gasket area of base clean and install new gasket in groove of new AC type PF-5 filter.

Lubricate gasket and screw filter on to stud of filter base hand tight. Start engine. Do not accelerate engine beyond normal idle until oil pressure is indicated. Check filter area for leaks after engine has run for five (5) minutes. See figure 1-1.

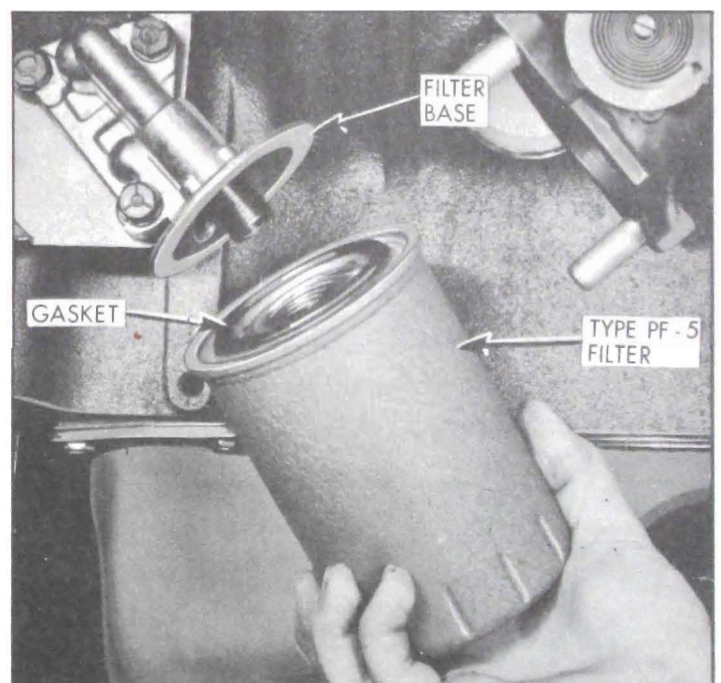
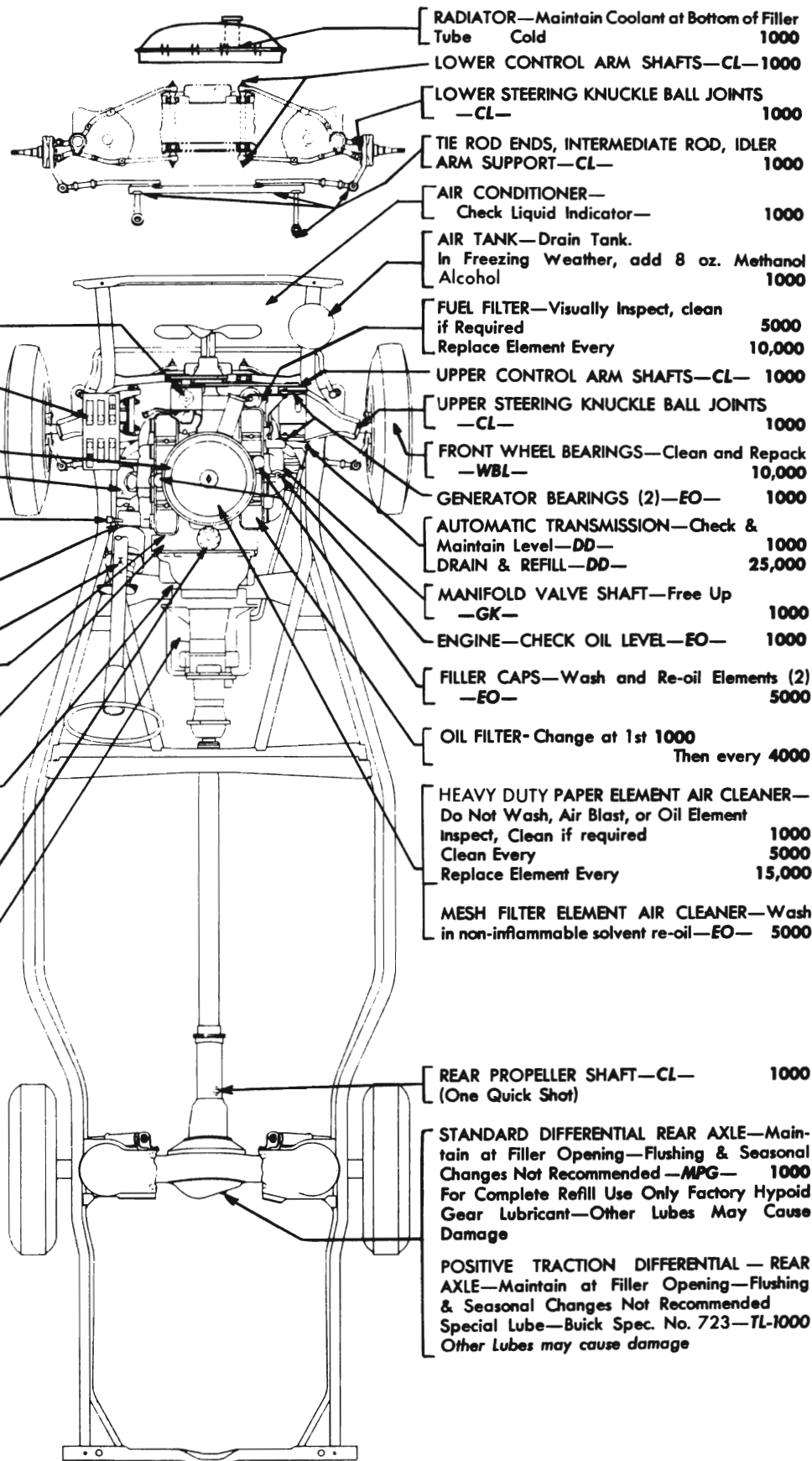

Figure 1-1—Oil Filter Installation

4. *Synchromesh Transmission.* Check oil level, after allowing time for oil to settle. Clean the surrounding area before removing filler plug. Level should be maintained at filler plug opening by adding Multi-Purpose Gear Lubricant (MIL 2105). Use SAE 90 for temperatures

### 1959 BUICK LUBRICATION CHART

LUBRICANTS	
CL	= Chassis Lubricant
DD	= Automatic Transmission Fluid, Type A (AQ-ATF)
EO	= Engine Oil (Current Viscosity)
GK	= Graphite & Kerosene
HBF	= Hydraulic Brake Fluid-Delco Super No. 11
LUB	= Lubriplate
MPG	= Multi-Purpose Gear Lubricant (MIL-2105)
WBL	= Wheel Bearing Lubricant
TL	= Lube Conforming to Buick Specification No. 723



- POWER STEER. RESERVOIR Check Oil Level  
-DD- 1000
- BATTERY—Add Distilled Water as Required.  
Do not Over-fill 1000
- CARTER CARB. PUMP C'SHAFT—EO— 5000
- STD. STEERING GEAR—MPG— 1000
- POWER BRAKE MASTER CYLINDER—Maintain  
Level so Visible in Filler Tube  
-HBF— 1000
- STANDARD BRAKE MASTER CYLINDER—Main-  
tain Level 1/2" to 1" Below Lip of Filler Opening  
-HBF— 1000
- HORN CABLE CONNECTOR—LUB— 5000
- THROTTLE EQUALIZER LINKAGE  
-LUB— 1000
- CLUTCH RELEASE EQUALIZER—CL— 1000
- CLUTCH LINKAGE PINS—EO— 1000
- THROTTLE, CLUTCH, STATOR AND  
TRANSMISSION SHIFT LINKAGE  
PIVOT POINTS—EO— 1000
- Do Not Oil Carburetor Linkage  
Do Not Lubricate Parking Brake Pulleys
- DISTRIBUTOR SHAFT—EO— 1000
- SYNCHROMESH TRANSMISSION—Maintain at  
Filler Opening—Flushing & Seasonal Changes  
Not Recommended—MPG— 1000

- RADIATOR—Maintain Coolant at Bottom of Filler  
Tube Cold 1000
- LOWER CONTROL ARM SHAFTS—CL—1000
- LOWER STEERING KNUCKLE BALL JOINTS  
-CL— 1000
- TIE ROD ENDS, INTERMEDIATE ROD, IDLER  
ARM SUPPORT—CL— 1000
- AIR CONDITIONER—  
Check Liquid Indicator— 1000
- AIR TANK—Drain Tank.  
In Freezing Weather, add 8 oz. Methanol  
Alcohol 1000
- FUEL FILTER—Visually Inspect, clean  
if Required 5000  
Replace Element Every 10,000
- UPPER CONTROL ARM SHAFTS—CL— 1000
- UPPER STEERING KNUCKLE BALL JOINTS  
-CL— 1000
- FRONT WHEEL BEARINGS—Clean and Repack  
-WBL— 10,000
- GENERATOR BEARINGS (2)—EO— 1000
- AUTOMATIC TRANSMISSION—Check &  
Maintain Level—DD— 1000  
DRAIN & REFILL—DD— 25,000
- MANIFOLD VALVE SHAFT—Free Up  
-GK— 1000
- ENGINE—CHECK OIL LEVEL—EO— 1000
- FILLER CAPS—Wash and Re-oil Elements (2)  
-EO— 5000
- OIL FILTER—Change at 1st 1000  
Then every 4000
- HEAVY DUTY PAPER ELEMENT AIR CLEANER—  
Do Not Wash, Air Blast, or Oil Element  
Inspect, Clean if required 1000  
Clean Every 5000  
Replace Element Every 15,000
- MESH FILTER ELEMENT AIR CLEANER—Wash  
in non-inflammable solvent re-oil—EO— 5000

- REAR PROPELLER SHAFT—CL— 1000  
(One Quick Shot)
- STANDARD DIFFERENTIAL REAR AXLE—Main-  
tain at Filler Opening—Flushing & Seasonal  
Changes Not Recommended—MPG— 1000  
For Complete Refill Use Only Factory Hypoid  
Gear Lubricant—Other Lubes May Cause  
Damage
- POSITIVE TRACTION DIFFERENTIAL — REAR  
AXLE—Maintain at Filler Opening—Flushing  
& Seasonal Changes Not Recommended  
Special Lube—Buick Spec. No. 723—TL-1000  
Other Lubes may cause damage

CAPACITIES	
Cooling System	
With Heater—Qts.	19
Without Heater—Qts.	16 1/2
Crankcase	
Refill—Qts.	4 (*5)
Dry Engine—Qts.	5 (*6)
*With Dry Oil Filter	
Gas Tank—Gal.	20
Rear Axle—Pts.	6 1/2
Transmission Refill	
Twin Turbine—Qts.	12
Triple Turbine—Qts.	12 1/2
Synchromesh—Pts.	2 1/2
Manual Steering Gear—Oz.	18
Power Steering	
Hydraulic System—Pts.	3

Figure 1-2—Chassis Lubricare Chart—All Series

not lower than 10°F. below zero; for temperatures continuously lower than -10°F. use SAE 80. NOTE: *Draining and flushing transmission is not necessary unless the lubricant has become contaminated.*

### 5. Rear Axle

(a) *Standard Differential Rear Axle.* Check oil level, after allowing time for oil to settle. Clean the surrounding area before removing filler plug. Level should be maintained at filler plug opening by adding SAE 90 Multi-Purpose Gear Lubricant (MIL-2105). When car is operated in temperatures continuously below -10°F., use SAE 80 Multi-Purpose Gear Lubricant. NOTE: *Draining and flushing is not recommended unless the lubricant has become contaminated.* When complete refilling is required use only Factory Hypoid Lubricant as specified in paragraph 1-7.

(b) *Positive Traction Differential Rear Axle.* Identified by embossed tag on filler plug reading, "Use limited slip differential lube only". Check lubrication level after allowing time for lubrication to settle. Clean the surrounding area before removing filler plug. Level should be maintained at filler plug opening by adding lubricant conforming to Buick specification #723 only, as specified in paragraph 1-7. See figure 1-3.

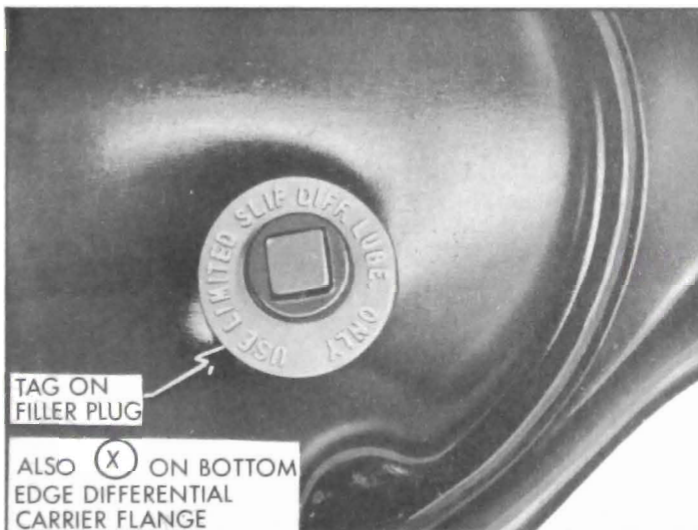

Figure 1-3—Identification of Positive Traction Differential Axle

6. *Automatic Transmission.* Check transmission oil level, with transmission oil warm, transmission in Park, and engine idling. Remove gauge rod located under right side of hood (fig. 1-5), wipe dry with clean cloth then reinstall to full depth. Remove rod and note oil level.

If oil level is more than one inch below the "FULL" mark on gauge rod, add oil specified

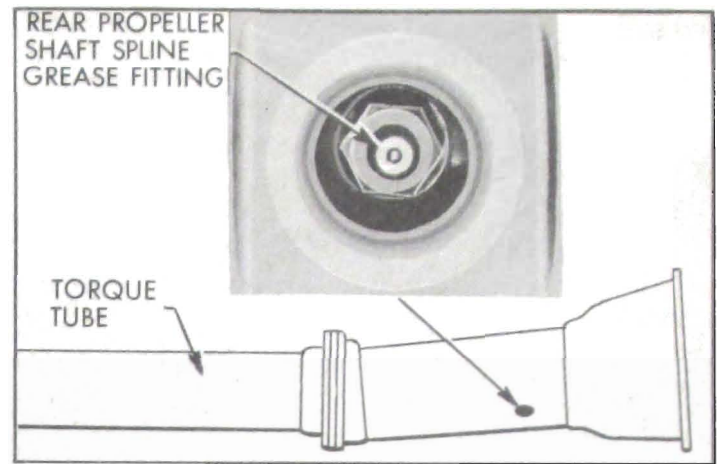

Figure 1-4—Rear Propeller Shaft Spline Grease Fitting

in paragraph 1-4 but do not fill above the "FULL" mark. Distance between the "FULL" and "ADD OIL" mark represents approximately one pint.

7. *Distributor.* Fill oil cup with light engine oil.

### 8. Air Cleaner

(a) *Heavy Duty Dry Type*—Normally serviced every 5,000 miles. If car is operating in dusty territory, check condition of air cleaner element and clean if dirty. See instructions in paragraph 1-2.

(b) *Oil Wetted Mesh Type*—Normally serviced every 5,000 miles. If car is operating in dusty territory, check condition of element. Wash and re-oil if necessary. See instructions in paragraph 1-2.

9. *Generator; Fan Belt.* Fill front and rear oilers to the caps with light engine oil. Wipe off excess or spilled oil.

Inspect fan belt for cracks and for proper tension. See figure 2-37.

10. *Radiator.* Check coolant level when engine is cold and add coolant to bottom of filler tube. CAUTION: *Radiator cap should not be*

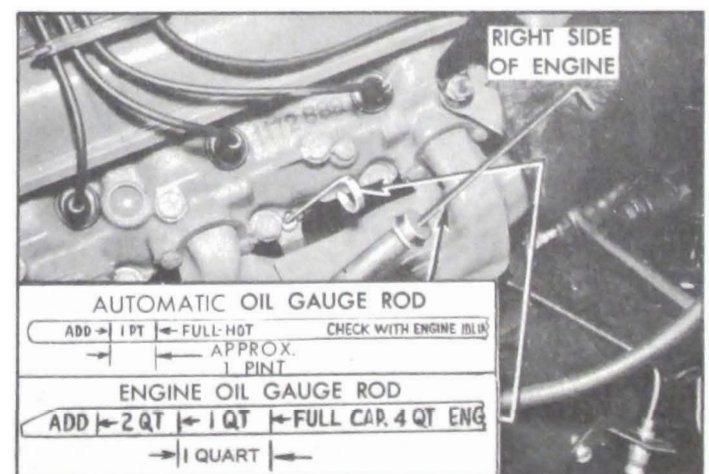

Figure 1-5—Engine and Auto. Trans. Oil Gauge Rods

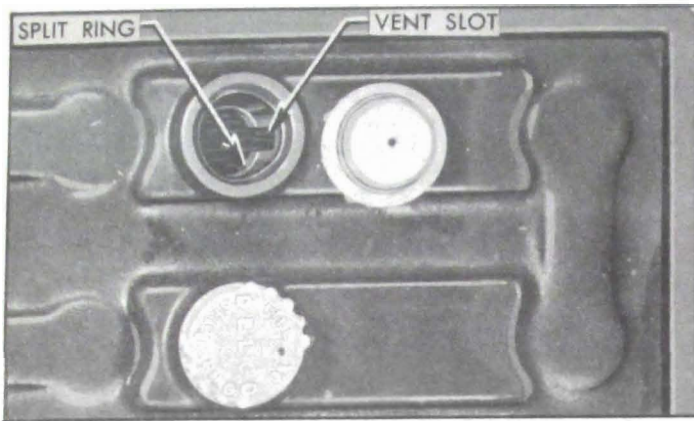

Figure 1-6—Battery Filler Well

removed when engine is hot because relieving the pressure may cause the cooling system to boil, with resultant loss of water or anti-freeze solution. Filling radiator above correct level may result in loss of water or anti-freeze solution through overflow pipe.

11. **Battery.** Add distilled water to bring level to split ring at bottom of filler well. **WARNING:** Do not overfill. Clean top of battery; if wet with acid, neutralize with soda and wash clean. See figure 1-6.

12. **Manifold Valve Shaft.** Place a few drops of graphited kerosene on shaft at each end and rotate shaft to work lubricant into bearings. See figure 1-7. If shaft is frozen, free up by tapping ends of shaft lightly with hammer.

13. **Manual Steering Gear.** Clean adjacent area, then remove gear housing filler plug. Add lubricant only as required to bring level to bottom of filler opening, using SAE 90 Multi-Purpose Gear Lubricant as specified for synchromesh transmissions (step 4). Seasonal or periodic change of lubricant is unnecessary.

14. **Power Steering Gear.** Thoroughly clean dirt from reservoir cap on top of oil pump, then remove cap. Add oil specified for automatic

transmission. See figure 1-8.

15. **Throttle, Clutch, Stator, and Transmission Shift Linkage Pivot Points.** Wipe dirt from pivot points, then apply a good grade of light oil. To lubricate throttle equalizer bearing, however, work Lubriplate into bearing. **CAUTION:** Never oil linkage on carburetor.

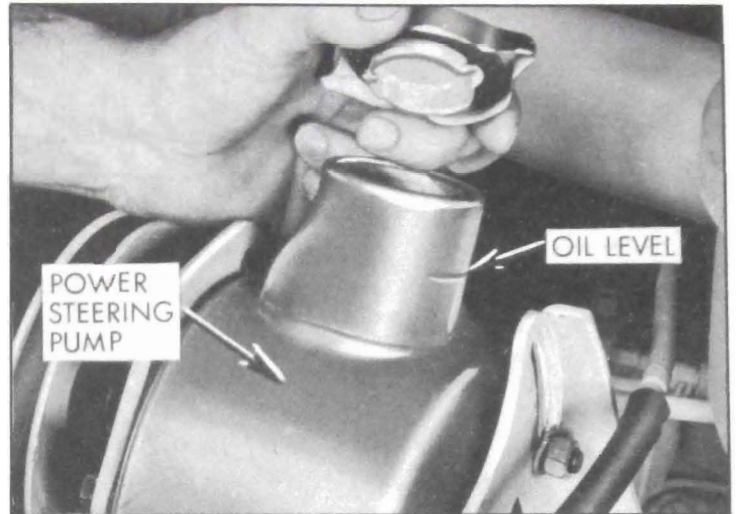

Figure 1-8—Power Steering Pump Reservoir

16. **Brake Master Cylinder.** On manual brake jobs reservoir is under hood on left side. (On dash panel).

Thoroughly clean filler cap nut before removal to avoid getting dirt into reservoir. Add fluid as required to bring level to  $\frac{1}{2}$ " to 1" below top of filler opening. Use G.M. or Delco Super No. 11 Hydraulic Brake Fluid. *Never use reclaimed fluid or any mineral oil.*

On power brake jobs, the brake master cylinder is mounted on toe board, left side. Level of fluid should be visible in filler tube. Use G.M. or Delco Super No. 11 Hydraulic Brake Fluid. *Never use reclaimed fluid or any mineral oil.* See figure 1-9.

17. **Tires.** Inflate all tires according to tire temperatures, as follows:

24 lbs. **Starting Pressure**—after car has been standing for 3 hours or driven less than one mile. 28 lbs. on Estate wagon rears.

26 lbs. **City Pressure**—after car has been driven 3 miles or more BELOW 40 MPH. 30 lbs. on Estate wagon rears.

28 lbs. **Highway Pressure**—after car has been driven 3 miles ABOVE 40 MPH. 32 lbs. on Estate wagon rears.

**WARNING:** It is impossible to inflate tires correctly when HOT. Pressure normally increases as tires heat up when driving. Do not deflate tires to offset this increase in pressure.

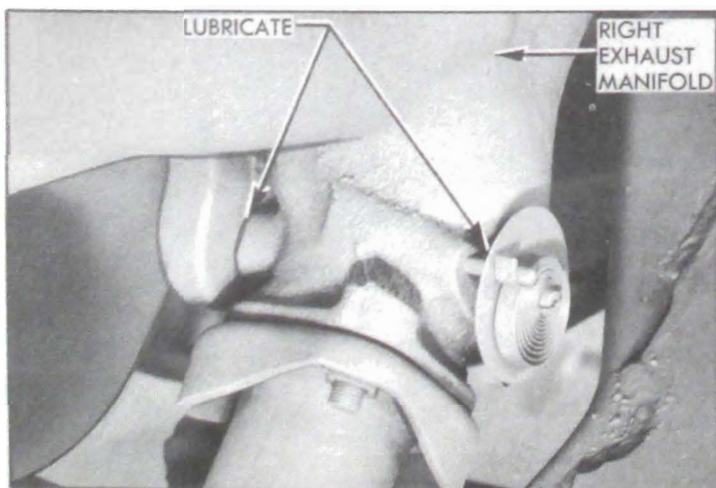

Figure 1-7—Manifold Valve

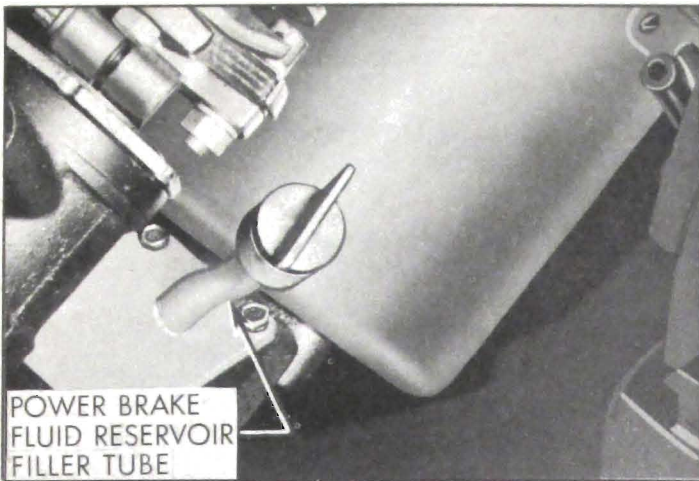

Figure 1-9—Power Brake Fluid Reservoir Filler Tube

18. *Air Ride Air Reservoir Tank.* Depress drain valve core just enough to allow condensed moisture to be blown out. Valve is located at bottom of tank, right side. See Figure 1-10.

In freezing weather, release all pressure from tank; remove fitting from top of tank and add 8 ounces methanol alcohol. *Do not use permanent type anti-freeze compound.* Reconnect fitting; check for leaks.

**NOTE:** *When necessary to drain tank completely for addition of alcohol, time may be saved by raising and lowering the rear of the car to reduce tank pressure; then removing the drain valve core, allowing the air to escape more rapidly.*

## 1-2 EVERY 5000 MILES—LUBRICARE

1. *Oil Filter.* See paragraph 1-1, step 3. (1,000 Mile Lubricare).



Figure 1-10—Air Ride Air Reservoir Tank Drain Valve

## 2. *Air Cleaner and Oil Filler Caps.*

(a) *Oil Filler Caps.* Every 5000 miles (more often under dusty operating conditions) remove the oil filler caps and wash the filtering elements in a non-inflammable solvent. **DO NOT USE KEROSENE.** Allow elements to drain until dry. Oil the elements and reinstall caps.

(b) *Heavy Duty Dry Element Air Cleaner.* For normal operating conditions, remove air cleaner dry element to clean and inspect it every 5000 miles (under dusty operating conditions, every 1000 miles). See figure 1-11.

To clean element, repeatedly drop squarely on a flat surface from a height of 2 inches until all loose dust has been removed. Turn element over and repeat process. Do not clean by any other method or element will be damaged. *Do not wash, air blast, or oil element.*

Thoroughly inspect the element visually for any breaks or holes in the fiber. Replace element if any possible dust leaks are found.

Replace element every 15,000 miles with a new AC type A-63-C element on 4 barrel carburetor jobs, or type A-86-C on 2 barrel carburetor jobs. Before installing element, wipe all loose dust from interior of air cleaner. When element and cover are in place, tighten wing nut securely by hand to insure a proper seal on the ends of the element.

(c) *Oil Wetted Mesh Element Air Cleaner.* Every 5,000 miles (more often if car is operated in dusty territory) wash element in non-inflammable solvent. **DO NOT USE KEROSENE.** Allow element to drain dry. Oil element liberally and allow excess to drain off; reinstall. See Figure 1-12.

**NOTE:** *If an oil wetted mesh type element is replaced with a heavy duty dry type element, care should be taken to thoroughly clean any oil or dirt out of the air cleaner housing before the dry type element is put in service.*



Figure 1-11—Heavy Duty Dry Type Air Cleaner Element

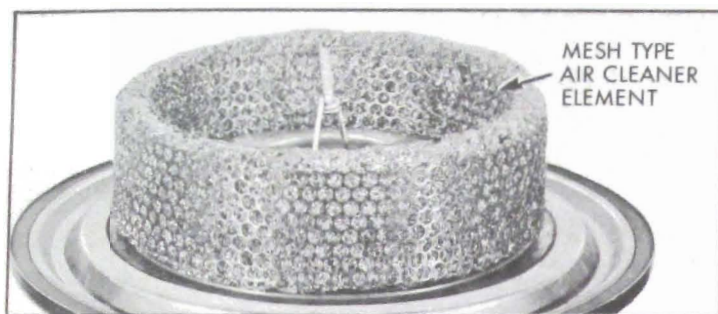

Figure 1-12—Oil Wetted Mesh Air Cleaner

3. *Pump Operating Countershaft—Carter Carburetor Only.* On 2-barrel carburetors, remove dust cover and apply oil in two oil holes above countershaft. See figure 1-13.

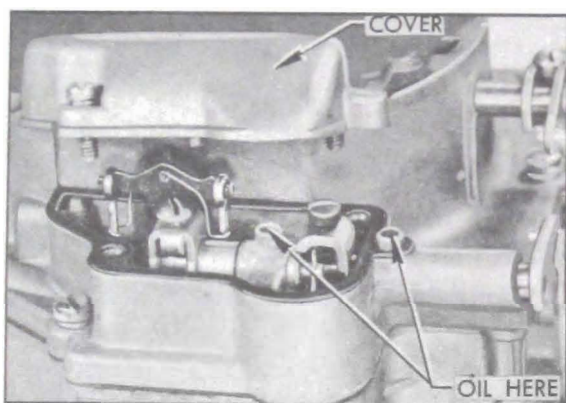

Figure 1-13—Countershaft Lubrication—Carter 2-Barrel

4. *Gasoline Filter.* Element normally replaced every 10,000 miles. However, visually inspect contents of glass bowl and clean if necessary. While bowl is off, inspect filtering element and gaskets and replace if necessary. See instructions in paragraph 1-3.

5. *Horn Cable Connector.* Pull out plunger of horn cable connector on steering column jacket and apply a small amount of Lubriplate. Work plunger in and out to work lubricant in between plunger and the bakelite insulator.

6. *Hood Latch and Hinges.* Lightly coat hood guide, latch, lever, and dovetail bolt with Lubriplate. Apply engine oil to hood hinge pins.

7. *Dome Lamp Door Switches.* Coat end of switch plunger and contact point on door with stick type lubricant.

8. *Glove Box Door.* Apply a few drops of light engine oil to door hinge and wipe off surplus. Sparingly coat lock striker with stick type lubricant.

9. *Gas Tank Filler Door.* Apply a few drops of light engine oil to hinge. Wipe off excess oil to prevent accumulation of dirt.

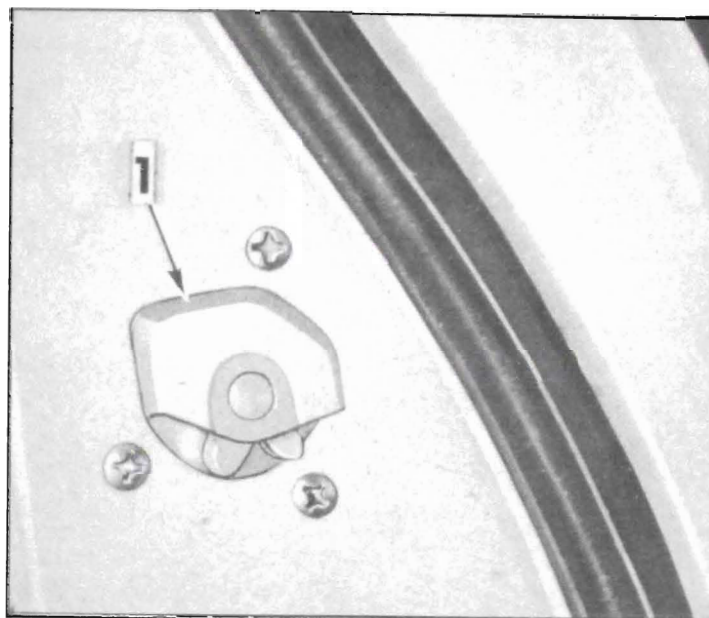

Figure 1-14—Lubrication of Door Lock

10. *Lock Cylinders.* If key operates roughly in any lock cylinder blow powdered graphite into key slot. **DO NOT USE OIL.**

11. *Front Door Hinge Hold-Open Clips.* Wipe off dirt and apply a light coat of Lubriplate or its equivalent to hold-open clips.

12. *Door Lock.* Wipe off dirt and apply a thin coat of stick type lubricant on top surface of lock bolt housing indicated at "1" in figure 1-14.

13. *Door Lock Striker.* Wipe off dirt and apply a thin coat of stick type lubricant to top surface of lock bolt striker teeth. After lubrication close door several times and remove excess lubricant along the side edge of teeth.

14. *Rear Door Hinge and Hold-Open Assembly.* Wipe off dirt and apply one or two drops of Lubriplate.

15. *Folding Top Linkage (Convertibles).* Apply a sparing amount of light engine oil to bearing points. Wipe off excess lubricant to prevent soiling trim.

16. *Side Roof Rail Weatherstrip.* Carefully apply silicone rubber lubricant to outer lip of weatherstrip contacted by upper edge of front door ventilator. On four door hardtop models also apply lubricant from a point just forward of upper front corner of rear door window rearward approximately 12".

17. *Rear Compartment Lid Hinges and Torque Rods.* Apply lubriplate or equivalent to torque rods and hinge at friction points.

18. *Rear Compartment Lid Lock Bolt.* Wipe off dirt and apply lubriplate or equivalent sparingly to slot in catch. Wipe off excess.

19. *Door Bottom Drain Hole Sealing Strip.* Apply sparing amount of silicone rubber lubricant to top surface of strip. This operation is performed to prevent lip of sealing strip from adhering to inner panel and plugging drain holes in bottom of door.

### 1-3 EVERY 10,000 MILES—LUBRICARE

#### a. Front Wheel Bearings

At 10,000 mile intervals, the front wheel bearings should be removed, cleaned, repacked with new front wheel bearing grease, and installed as specified in Paragraph 7-10.

#### b. Fuel Filter Element

Each 10,000 miles, remove glass bowl and clean. Soak bowl in a good cleaning solvent to loosen any deposits. Replace element with AC

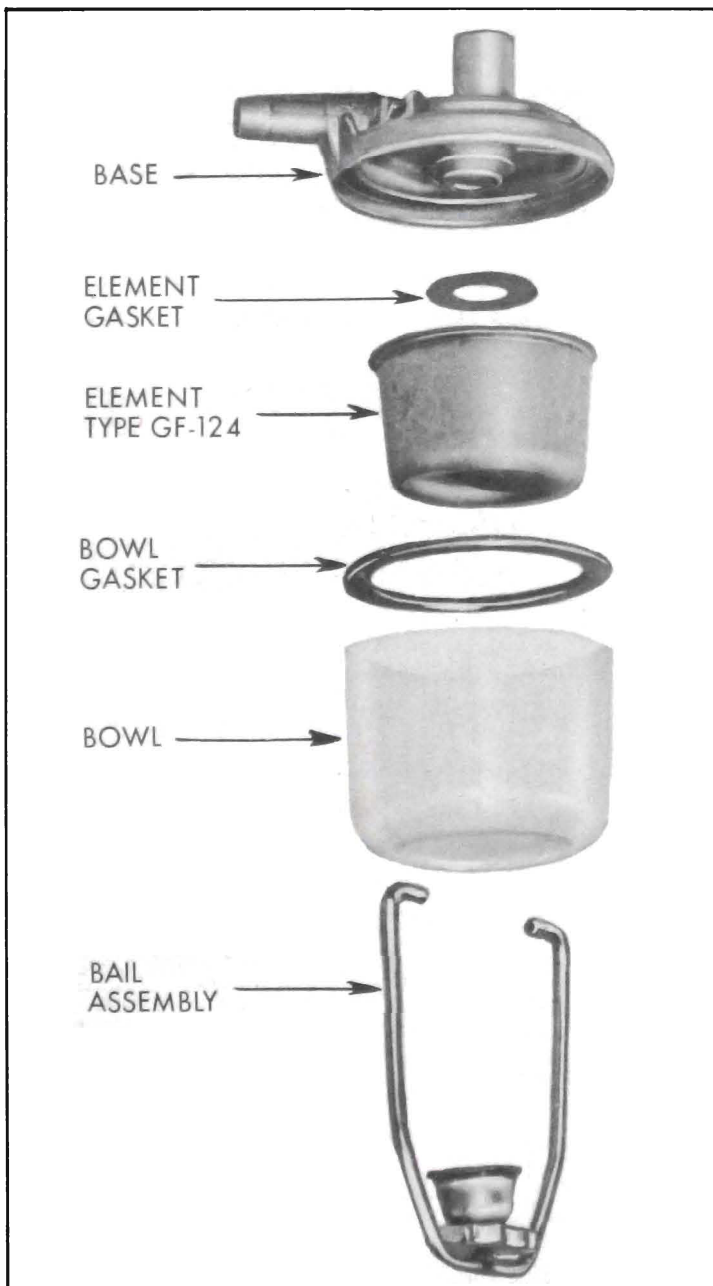

Figure 1-15—Fuel Filter Exploded View

type GF-124 element. Wipe bowl clean and reinstall, tightening bail finger tight. After assembling fuel filter, always start engine and observe filter carefully to make sure gasket is not leaking. See Figure 1-15.

### 1-4 EVERY 25,000 MILES— AUTOMATIC TRANSMISSION

At 25,000 mile intervals the transmission should be completely drained, the oil pan and screen should be removed and cleaned, and the transmission should be refilled with fresh oil. Transmission MUST NOT BE FLUSHED when oil is changed.

#### a. Approved Oils for Buick Automatic Transmissions

The following oils are approved for Buick Automatic Transmission and no other fluid should be used.

1. *Special Buick Oil* available through Buick Parts Warehouses under Group 4.101.
2. *Automatic Transmission Fluid, Type A*, available through petroleum suppliers. This

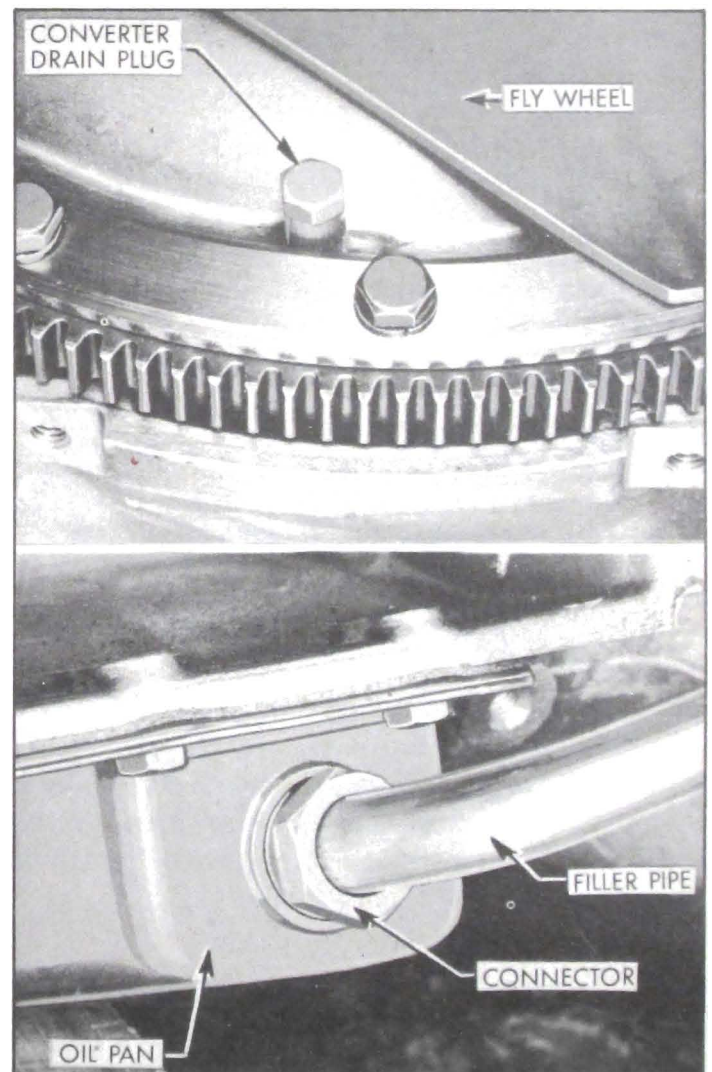

Figure 1-16—Automatic Transmission Drain Points

fluid must have an AQ-ATF number embossed in lid of the can for identification.

#### **b. Draining and Refilling Automatic Transmission**

1. Warm up transmission, then remove bell housing cover.

2. Loosen one converter drain plug, then turn converter until opposite drain plug is straight down and remove this plug to allow converter to drain completely. See figure 1-16.

3. Remove filler pipe fitting from oil pan and allow oil pan to drain completely. *Do not remove accumulator caps on Twin Turbine transmission.* See figure 1-16.

4. Remove oil pan and oil screen, clean thoroughly, and reinstall. Install and tighten drain plugs and filler pipe, then install bell housing cover.

5. Put 3 quarts of specified oil (subpar. a.) in transmission. With engine idling and transmission in Parking (P) complete the refilling to bring oil level to "FULL" mark on gauge rod. When transmission oil is warmed up, the oil level should then be at "FULL" mark on gauge rod.

A Twin Turbine transmission refill requires approximately 12 quarts to refill. A Triple Turbine transmission requires approximately 12½ quarts to refill. A completely dry transmission requires an additional 1¾ pints.

### **1-5 LUBRICARE—AS REQUIRED OR WHEN ACCESSIBLE**

#### **a. Clutch Internal Lubricare**

Lubrication of internal working parts of the clutch is usually required only at time clutch is assembled and installed; however, if lubrication becomes necessary to eliminate squeaks or correct excessive pedal pressure, follow instructions given in paragraph 4-4.

#### **b. Brake Lubricare**

Lubrication of all metal contact points at wheel brake assemblies is normally performed during the major brake adjustment or may be

performed whenever a brake drum is removed.

Lubrication of parking brake cables is also performed during the major brake adjustment; however, operation under conditions where mud and water are frequently encountered may require more frequent lubrication. See paragraph 9-9.

#### **c. Rear Wheel Bearing Lubricare**

Rear wheel bearings are lubricated by gear lube splash from the differential housing and need no other lubrication. Whenever rear brakes are relined, or drums are removed for other work, it is advisable to inspect for evidence of leaking rear wheel bearing oil seals. Replace seals if leaking.

#### **d. Speedometer Cable Lubricare**

The speedometer cable is factory lubricated with special all-season grease and normally requires no further service unless it becomes noisy. In extremely hot climates or where considerable dirt and water are encountered, however, it may be necessary to lubricate the cable at intervals of approximately 20,000 miles or every two years. See paragraph 10-58.

#### **e. Sunshade Lubricare**

If the sunshade rod turns hard in the support as sunshade is moved up and down, remove retainer screw, pull rod from support and apply stick type lubricant. *Do not use oil, which may soil body trim.* Install rod in support and adjust retainer screw to proper tension.

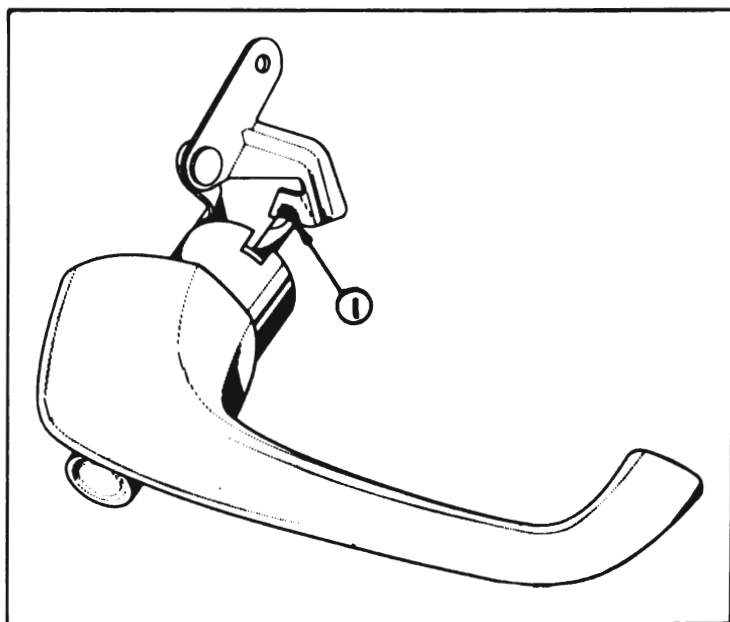

Figure 1-17—Lubrication of Door Outside Handle



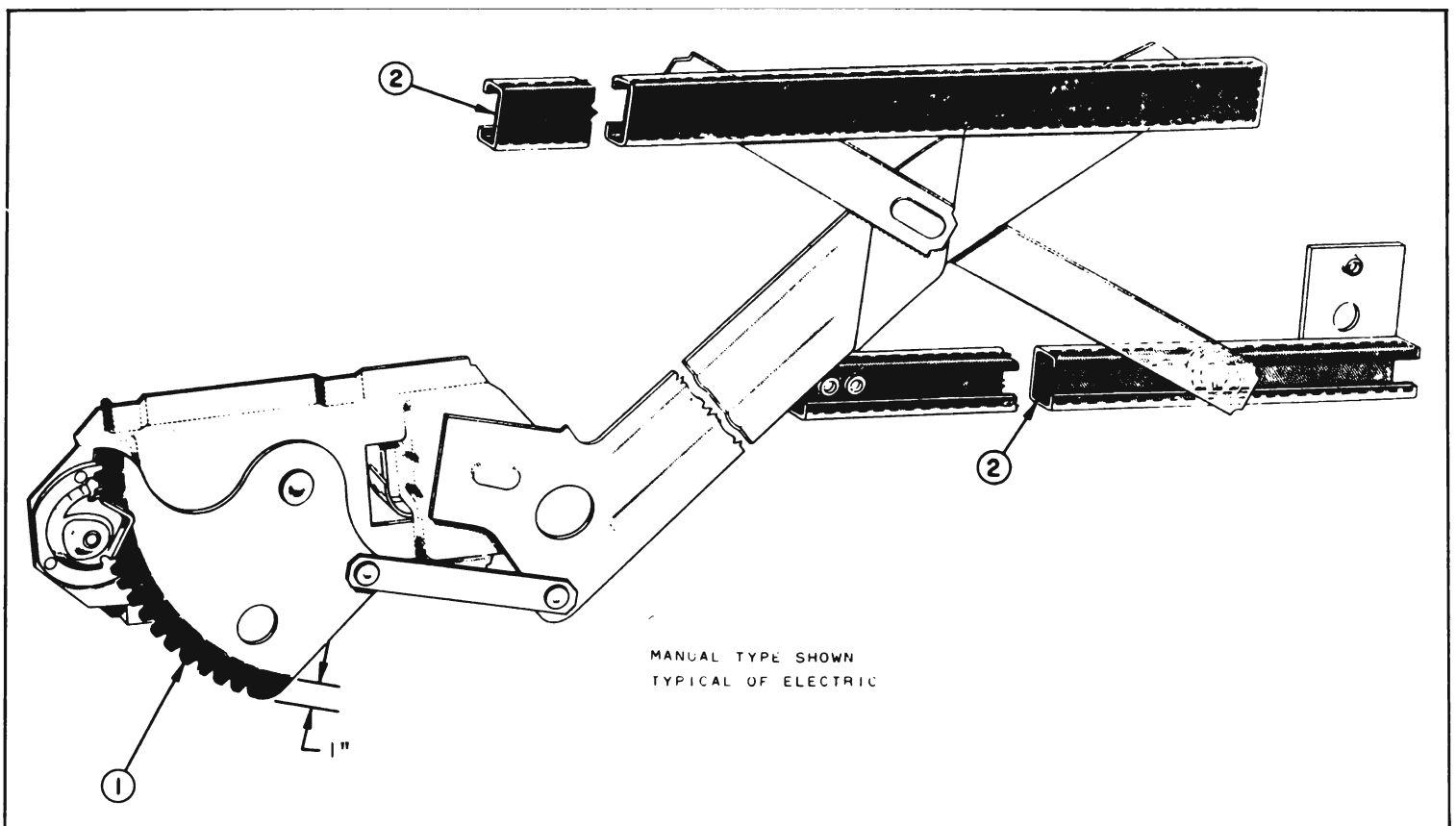

Figure 1-18—Lubrication of Front and Rear Door Window Regulator and Channels

#### f. Door Lock Outside Handle

Apply light coat of Lubriplate or its equivalent to surface of lock cylinder shaft contacting the bell crank indicated at "1" in figure 1-17.

#### g. Door Lock Parts

Lubricate moving parts of door lock with Lubriplate or its equivalent.

#### h. Front and Rear Door Window Regulator Sector and Channels

Apply a coat of Lubriplate or its equivalent to location of regulator sector indicated at "1" and to sliding surface of window cam and guide channels indicated at "2" in figure 1-18. Although the channel and guide assemblies are different on the rear doors, lubrication of the front door parts is typical of lubrication required on rear door parts.

#### i. Seat Regulator Jack Screw (Six-Way Seat)

Thoroughly wipe off old lubricant; then apply Lubriplate or its equivalent to jack screw. Operate seat adjuster to limit of all positions and wipe off excess lubricant.

#### j. Rear Compartment Gutter Weatherstrip

Carefully apply a coat of silicone rubber lubricant to surface of gutter weatherstrip and along length of weatherstrip. The weatherstrip should be lubricated whenever the action of the compartment lid is retarded due to friction with the weatherstrip.

#### k. Door Locking Mechanism

Apply Lubriplate or its equivalent at pivot joints of inside locking rods as indicated by arrows in figure 1-19.

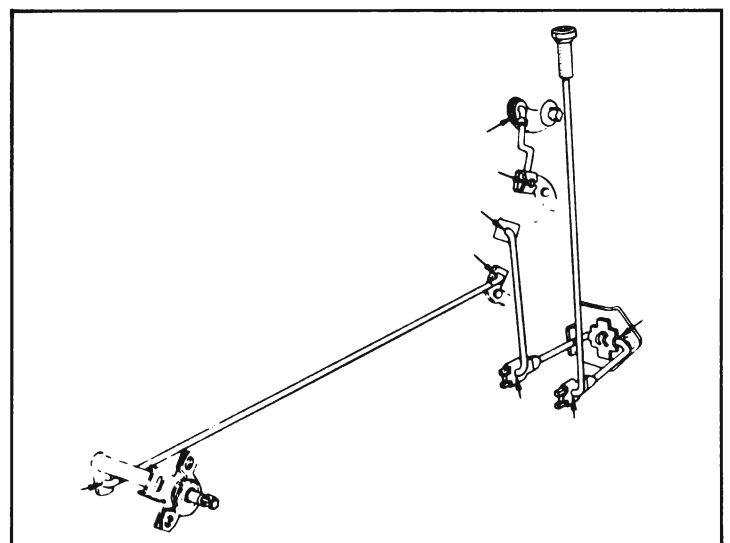

Figure 1-19—Lubrication of Door Locking Mechanism

## 1-6 ENGINE OIL RECOMMENDATIONS

### a. Choice of Engine Oil

(1) *Brand of Oil.* In the selection of the proper brand of oil it is essential to consider the reputation of the refiner or marketer. *It is recommended that the same brand of oil be used at all times.*

(2) *Type of Oil.* There are several types of oil manufactured for use in internal combustion engines. For use in the Buick engine we recommend that a *heavy duty type* oil marked "For Service MS" or "For Service DG" be used for maximum protection under all driving conditions. Oils marked "For Service MM" or "For Service ML" are *not recommended* for any Buick engine.

(3) *Grade or Viscosity.* The grade or viscosity (SAE number) of engine oil should be selected for the lowest anticipated temperature at which *cold* engine starting will be required as recommended in the temperature-viscosity chart below.

(4) *Break-in Oils.* Break-in oils or compounds are not necessary in Buick engines and their use is not recommended. Some of these break-in oils contain certain materials which may be harmful. Buick HD Concentrate (sub-par. d) is not a break-in oil.

### b. When to Change Engine Oil

The crankcase should be completely drained and refilled with new oil of proper viscosity at the end of the first 1,000 miles and every 2,000 to 3,000 miles thereafter. Adverse driving conditions require more frequent draining and refilling. Adverse driving conditions are those which may cause early contamination of engine oil, such as operation under unusual dust conditions or short runs with a cold engine.

The color of "Service MS" type oil does not indicate its condition since it normally becomes dark (black or gray) after only a few hundred miles of driving. This is because the detergent content envelopes and holds in suspension extremely fine but harmless soot (soft carbon)

and lead particles. The oil filter element does not remove this harmless material but it does remove all harmful particles such as road dust, metal chips and hard carbon.

Engine crankcase oils have a definite effect on ease of starting, oil economy, combustion chamber deposits and engine wear. Many commercial crankcase oils contain heavy non-volatile deposit forming components which make the type of combustion chamber deposits that greatly increase detonation and particularly pre-ignition, even though these oils may be designated "For Service MS" or "For Service DG." Some commercial crankcase oils are deficient in anti-wear characteristics and may contribute to rapid wear of camshafts, valve lifter assemblies and other highly stressed engine parts. Owners should be urged to use only crankcase oils that have been proven to produce ease of starting, satisfactory oil economy, minimum combustion chamber deposits and adequate protection against wear.

### c. Crankcase Flushing

Flushing the crankcase with oils or solutions other than a good grade of 10-W engine oil is not recommended. When flushing to remove contamination appears advisable, use 3 quarts 10-W oil (4 quarts if filter is drained) and idle the engine at 1000 RPM (equivalent to 20 MPH) until the oil is hot, then drain crankcase and oil filter immediately after stopping engine. Fill crankcase with correct quantity and seasonal grade of oil.

### d. Use of Buick HD Concentrate

Buick HD Concentrate, available through Buick Parts Department under Group 1.850 is a compound of the materials used by oil refiners to manufacture high detergency motor oils. It is intended for use in engines operating under aggravated conditions where engine deposits, rust and corrosion cannot be adequately retarded by motor oils readily available to the average motorist. It is especially recommended for engines operated under restricted conditions such as frequent stops, short trips and

### Temperature—Viscosity Chart

<i>Temperature</i>	<i>Single Viscosity</i>	<i>Multi-Viscosity</i>
Not lower than +32° F	SAE 20 or 20W	SAE 10W-30 or SAE 10W-20
Not lower than -10° F	SAE 10W	SAE 10W-30 or SAE 10W-20
Below -10° F	SAE 5W	SAE 5W-10 or SAE 5W-20

slow speeds where such symptoms as sticking valves, valve lifters and rings are noticed.

Although HD Concentrate may be used continually it is normally unnecessary to use it with every crankcase refill. When used, the instructions on the container should be carefully observed.

## 1-7 REAR AXLE LUBRICANT RECOMMENDATIONS

### a. Standard Differential Axle

Buick standard rear axles are filled at the factory with a special hypoid gear lubricant. It is not necessary to remove the original lubricant at any time except when it has become contaminated, or when it is required for inspection of parts or for repairs. Therefore there is no drain hole in the rear axle housing.

*Under no circumstances should the factory lubricant be removed from the rear axle to be replaced with any other type of lubricant.*

In all cases of complete refilling of standard rear axle only *Factory Hypoid Gear Lubricant* is recommended. This is the same lubricant (lead soap—active sulphur type) as furnished with Buick replacement ring and pinion gear sets, and it may be obtained from any Buick Parts Warehouse under Group 5.535.

When *adding* lubricant to bring it to proper

level *Factory Hypoid Gear Lubricant* is preferred; however, SAE 90 Multi-Purpose Gear Lubricant (MIL-2105) may be added.

In temperatures consistently below  $-10^{\circ}$  F add SAE 80 Multi-purpose gear lubricant.

### b. Positive Traction Differential Axle

Buick Positive Traction Differential Axles are filled at the Factory with a special lubricant conforming to Buick Specification No. 723. It is not necessary to remove the lubricant at any time except when it has become contaminated or when it is required for inspection of parts or for repairs. There is no drain hole in the rear axle housing.

In all cases of adding lubricant to bring to proper level or complete refilling of Positive Traction Rear Axle, *only lubricant conforming to Buick Specification No. 723 may be used.* Lubricant conforming to this specification may be obtained from any Buick Parts Warehouse under Group 5.535.

Positive Traction Differential Rear Axles can be identified by an embossed tag affixed to the rear axle filler plug which reads, "Use Limited Slip Differential Lube Only". Also, a letter "X" inside a letter "O" is stamped on the bottom of the differential carrier casting just forward of the rear axle housing and is visible from beneath the car. See figure 1-3.