

SECTION 9-C

BRAKE SERVICE, ADJUSTMENT, REPAIR PROCEDURES

CONTENTS OF SECTION 9-C

Paragraph	Subject	Page	Paragraph	Subject	Page
9-7	Filling, Bleeding, Flushing Brake Hydraulic System	9-12	9-12	Inspecting and Reconditioning Brake Drums	9-19
9-8	Minor Brake Adjustment	9-14	9-13	Brake Wheel Cylinder Over- haul	9-20
9-9	Parking Brake Adjustment— Cable Lubrication	9-15	9-14	Brake Master Cylinder Over- haul	9-21
9-10	Major Brake Adjustment	9-16			
9-11	Replace or Reline Brake Shoes .	9-17			

NOTE: See Paragraph 9-16 for Power Brake Cylinder Service.

9-7 FILLING, BLEEDING, FLUSHING BRAKE HYDRAULIC SYSTEM

a. Filling Brake Master Cylinder

The master cylinder must be kept properly filled to insure adequate reserve and prevent air from entering the hydraulic system. *It must not be overfilled*, however, as expansion due to heat absorbed at brakes and from engine would cause fluid to overflow through the vent in filler cap nut. The overflow fluid would accumulate road dust and grit which increases the possibility of foreign material getting into the hydraulic system. Dirt accumulated over the vent holes would affect operation of the master cylinder.

On all cars (with regular or power brakes), the brake fluid reservoir is on the master cylinder which is located under the hood on the left side.

Thoroughly clean filler cap nut before removal to avoid getting dirt into reservoir. Add fluid as required to bring level $\frac{1}{2}$ " to 1" below lip of filler opening. When checking a power brake cylinder, the level is okay if the brake fluid is visible in the filler tube. Use G.M. or Delco Super No. 11 Hydraulic Brake Fluid.

CAUTION: Do not use shock absorber fluid or any other fluid which contains mineral oil. Do not use a container which has been used for mineral oil. Even a trace of mineral oil will cause swelling and distortion of rubber parts in the hydraulic brake system.

Check for clear vent holes in filler cap nut and make sure gasket is in good condition before installing cap nut.

b. Bleeding Brake Hydraulic System

A bleeding operation is necessary to remove air whenever it is introduced into the hydraulic brake system. Since air is compressible and

hydraulic fluid is not, the pressure of air in the system is indicated by a springy, spongy feeling on the brake pedal accompanied by poor braking action.

Air will be introduced into the hydraulic system if the brake pedal is operated when the fluid is too low in master cylinder reservoir. Air will also enter the system whenever any part of hydraulic system is disconnected.

It will be necessary to bleed the hydraulic system at all four wheel cylinders if air has been introduced through low fluid level or by disconnecting brake pipe at master cylinder. If brake pipe is disconnected at any wheel cylinder, then that wheel cylinder *only* need be bled. If pipes are disconnected at any fitting located between master cylinder and wheel cylinders, then all wheel cylinders served by the disconnected pipe must be bled. See figure 9-4.

c. Sequence for Bleeding Wheel Cylinders

It is advisable to bleed one wheel cylinder at a time to avoid getting fluid level in reservoir dangerously low. The correct sequence of bleeding is left front, right front, left rear, right rear. This sequence expels air from the lines and wheel cylinders nearest to the master cylinder first, and eliminates the possibility that air in a line close to the master cylinder may enter a line farther away after it has been bled.

CAUTION: Do not perform bleeding operation while any brake drum is removed.

d. Bleeding Wheel Cylinder Without Pressure Tank

1. Fill master cylinder (subpar. a, above).
2. Slip a brake bleeder tube over ball of wheel cylinder bleeder valve. Place lower end of bleeder tube in a clean glass jar. Unscrew bleeder valve $\frac{3}{4}$ of a turn. See figure 9-6.

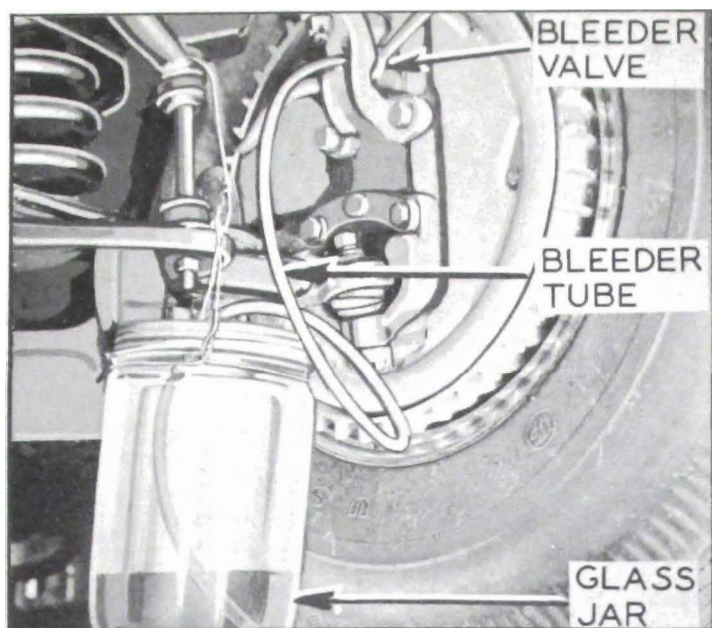

Figure 9-6—Bleeding Front Wheel Cylinder

3. Depress brake pedal a full stroke, then allow pedal to return slowly to released position. *Allowing pedal to return quickly may draw air into system.* Continue operating pedal in this manner until fluid flows from bleeder tube into glass jar in a solid stream that is free of air bubbles, then close the bleeder valve securely and remove bleeder tube.

4. Frequently check master cylinder to make sure that it contains fluid. *Allowing reservoir to be emptied will cause air to be drawn into hydraulic system.*

5. When bleeding operation is completed at all wheel cylinders where needed, make sure that fluid level is $\frac{1}{2}$ " to 1" below lip of master cylinder filler opening, then install filler cap nut and gasket.

6. Discard the brake fluid deposited in glass jar during bleeding operation. It is poor economy to attempt to clean fluid that has once been used.

e. Bleeding Wheel Cylinder with Pressure Tank

IMPORTANT: When using a pressure tank, air bubbles may form in the tank and enter the brake hydraulic system. To avoid this, observe the following points when handling a pressure tank: (1) Do not shake or agitate the pressure tank after air pressure has been added or is being added. (2) Allow pressure tank to stand in one position as much as possible, and bring air hose over to tank when adding head of air. (3) Make certain the valves on the pressure tank lines are not defective allowing air to be sucked in when fluid passes through the lines. (4) Pres-

sure tank should be kept at least $\frac{1}{3}$ full of fluid to avoid air bubbles forming. (5) If pressure tank is full of air bubbles, release air pressure and those bubbles will increase in size and be forced to top of fluid, and escape.

1. Thoroughly clean master cylinder filler cap nut and surrounding area, then remove cap nut.

2. Make sure that pressure tank is at least $\frac{1}{3}$ full of specified brake fluid, that hose and master cylinder reservoir are filled with fluid, then attach hose to master cylinder filler opening.

3. Slip a brake bleeder tube over ball of wheel cylinder bleeder valve. Place lower end of bleeder tube in a clean glass jar. Unscrew bleeder valve $\frac{3}{4}$ of a turn. See figure 9-6.

4. Open pressure tank hose valve to apply fluid to master cylinder under pressure that does not exceed 35 pounds. *Too much pressure may blow out the expansion plug in master cylinder.* It is not necessary to pump the brake pedal when using pressure tank.

5. When fluid flows from bleeder tube into glass jar in a solid stream that is free of air bubbles, that particular cylinder and line are bled; tighten bleeder valve securely, remove bleeder tube and install cover on bleeder valve.

6. When bleeding operation is completed at all wheel cylinders where needed, make sure that fluid level is $\frac{1}{2}$ " to 1" below top of master cylinder filler opening then install filler cap nut and gasket.

NOTE: *When checking a power brake cylinder, the level is okay if the brake fluid is visible in the filler tube.*

f. Flushing Brake Hydraulic System

It is recommended that the entire hydraulic system be thoroughly flushed whenever new parts are installed in the hydraulic system, or new shoes or linings are installed. Flushing is also recommended if there is any doubt as to the grade of fluid in the system or if fluid has been used which contains the slightest trace of mineral oil.

Flushing is performed at each wheel cylinder in turn, and in the same manner as the bleeding operation except that bleeder valve is opened $1\frac{1}{2}$ turns and the fluid is forced through the pipes and wheel cylinder until it emerges clear in color. Approximately one quart of fluid is required to flush the hydraulic system thoroughly.

When flushing is completed at all wheel cylinders, make certain that master cylinder reservoir is filled to proper level.

9-8 MINOR BRAKE ADJUSTMENT

The minor brake adjustment is intended for use where braking action is equal and generally satisfactory except that brake pedal goes too close to toeboard due to wear of brake linings. If braking action is unequal or otherwise unsatisfactory, the major brake adjustment should be used (par. 9-10).

Do not adjust when brakes are warm. Brake drums should be approximately room temperature.

a. Preliminary Checks

1. Jack up all four wheels in a safe manner.
2. Remove one front wheel with hub and drum assembly. Inspect brake lining. If lining is worn nearly to rivets, reline brakes (par. 9-11).
3. Check fluid level in master cylinder reservoir and add fluid if necessary (par. 9-7).
4. Fully release parking brake lever and place transmission in neutral.
5. Pull on both ends of rear brake cable a number of times to make sure that cables operate rear brake shoes freely and do not bind in conduits. Check for free movement of cable in brake cable sheave and check brake cable spring for tension. If cable action is not free, the cable and sheave should be lubricated (par. 9-9). Replace a weak or broken cable spring.
6. Check all anchor pin nuts to make certain nuts are tight. If an anchor pin nut is found loose, reset anchor pin as instructed in paragraph 9-10, step 19; otherwise *do not disturb anchor pins.*

b. Brake Pedal Height Adjustment

NOTE: *Power brake pedal height cannot be adjusted.*

Correct brake pedal height is important to insure adequate pedal travel and to make sure that the pedal is in the proper position to get the best linkage action.

1. Make certain that brake pedal returns completely when released slowly. If pedal does not return freely, check linkage for binding.

2. Measure from left top side of pedal pad perpendicular to toepan using a foot ruler. Pedal height with ruler pressed firmly against floor mat should be between 7½ and 8 inches. On synchromesh cars, brake pedal height should be within ¼ inch of clutch pedal height.

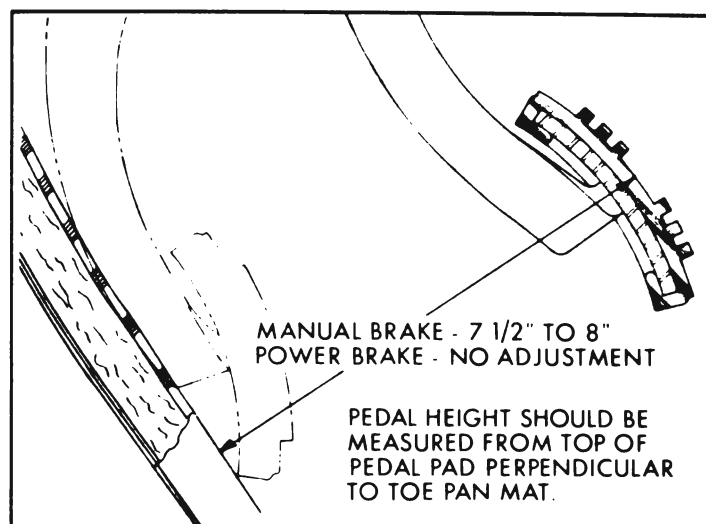

Figure 9-7—Brake Pedal Height Adjustment

3. If pedal height is incorrect, loosen push rod lock nut.

4. Rotate push rod as necessary to adjust pedal height to 7¾ inches on automatic transmission cars, or same as clutch pedal height on synchromesh transmission cars.

5. Hold push rod and tighten lock nut. Re-check pedal height.

6. Depress brake pedal firmly. If pedal travels to within 2 inches of toeboard and has a hard feel, brake shoes require adjustment or relining. However, if pedal has a spongy feel, brake system needs bleeding.

c. Adjustment at Wheels

1. Remove adjusting hole covers from brake backing plates. Using suitable tool to turn brake adjusting screw, expand brake shoes at each wheel until the wheel can just be turned by hand. Moving end of tool in hand upward expands the shoes. See figure 9-8. The drag should be equal at all wheels.

2. Back off brake adjusting screw at each wheel 15 notches. If shoes still drag lightly on drum, back off adjusting screw one or two additional notches, NOTE: *Brakes should be free of drag when screw has been backed off approximately 6 notches. Heavy drag at this point indicates improper anchor pin setting or tight parking brake cables.*

3. Install adjusting hole covers in all brake backing plates when adjustment is completed.

4. Check parking brake by depressing parking brake pedal. If pedal does not go down at least 2 inches, cable adjustment is too tight and may cause dragging brake shoes; or cables may be seized due to rust. If pedal *reserve* is

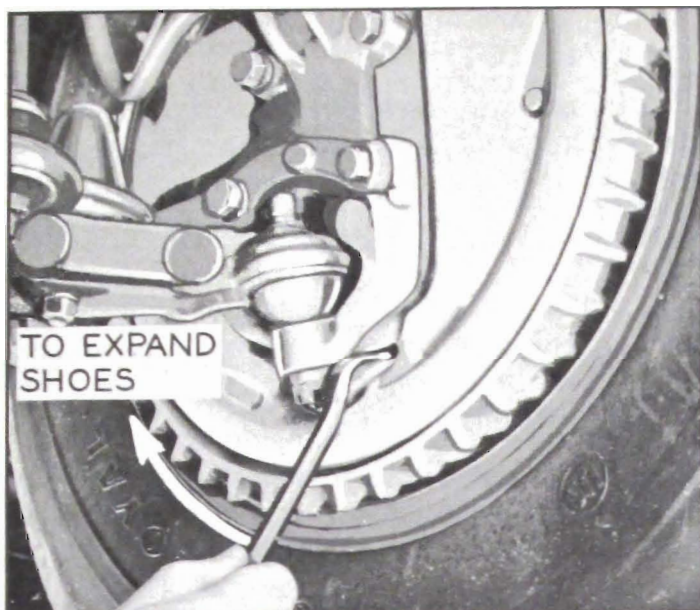

Figure 9-8—Expanding Brake Shoes

less than 3 inches, cable adjustment is too loose. Adjust or lubricate cables as necessary (par. 9-9).

5. Remove jacks and road test car for service and parking brake performance (par. 9-5).

9-9 PARKING BRAKE ADJUSTMENT-CABLE LUBRICATION

a. Adjustment

Adjustment of the parking brake is necessary whenever the rear brake cable has been disconnected or when the cables have stretched due to extended use. Need for a parking brake adjustment is indicated if the service brake operates with a good pedal reserve, but the parking brake pedal can be depressed to within 3 inches of the toeboard.

1. Make minor brake adjustment as described in paragraph 9-8 (subpar. c).

2. With parking brake lever fully released, check rear brake cable for proper amount of slack by pulling down on one side of cable midway between conduit clip and cable sheave. If properly adjusted, cable can be pulled down approximately 2 inches from its normal position. See figure 9-9.

3. To adjust cable slack, hold brake lever cable end to prevent twisting and turn cable adjusting nut as required. **CAUTION:** *Never make a parking brake adjustment without first making a minor brake adjustment.*

4. Recheck parking brake adjustment by making sure rear wheels turn freely when brake is released.

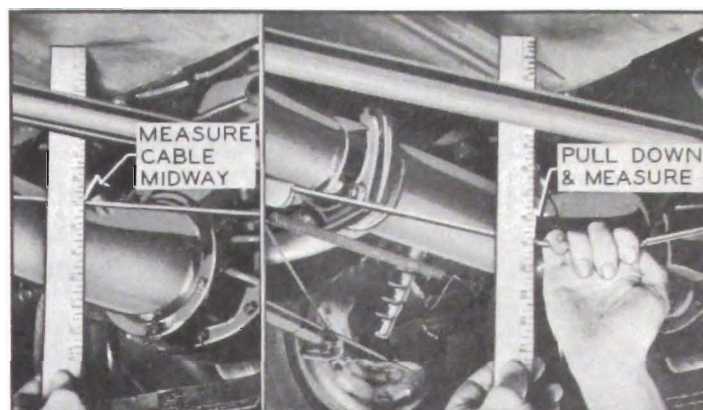

Figure 9-9—Checking Parking Brake Cable Adjustment

b. Cable Lubrication

Lubrication of parking cables is not included in Lubricare Instructions (par. 1-1) since these cables are usually lubricated during a major brake adjustment. Vehicles habitually operated under conditions where mud and water are frequently encountered may require more frequent lubrication to insure free action and avoid excessive wear of cables.

1. Disconnect brake lever cable at cable sheave (equalizer). See figure 9-3.

2. Disconnect rear brake cable conduits from rear brake backing plates and from clips on strut rods.

3. Slide each conduit away from backing plate and coat the cable sparingly with Bendix or Delco Brake Lubricant, or Lubriplate. Also lubricate cable where it passes through the sheave and make sure cable slides freely in sheave.

4. Slide conduit to within 2" of normal position, then clean surplus lubricant from cable at backing plate to avoid forcing it into brake assembly where it will get on brake linings.

5. Connect conduits to clips on strut rods and to backing plates.

6. Although the brake lever cable conduit rarely needs lubrication it may be lubricated at this time by sliding the conduit section forward. To do this, disconnect the rear end of the conduit by removing the spring yoke at the rear bracket. Disconnect the front end of the conduit by removing the tapping screws holding the clamp bracket to the frame cross member. Wipe cable forward of conduit clean, then slide conduit forward as far as possible and coat the exposed cable with graphite lubricant or Lubriplate. Slide conduit back and reconnect front and rear ends. Wipe off any excess lubricant.

7. Check operation of parking brake and adjust if necessary (subpar. a).

9-10 MAJOR BRAKE ADJUSTMENT

The major brake adjustment is intended for use when new shoes or linings are installed. It is also to be used when brake action is unequal, severe, or otherwise unsatisfactory.

Throughout the adjustment procedure *additional operations are specified* where inspection indicates their need. Each additional operation is *identified by an asterisk (*)* preceding the reference to paragraph number covering the operation. The major brake adjustment combined with required additional operations constitute a general overhaul of the entire brake mechanism.

1. Jack up car in a safe manner and remove all wheels.

2. Check fluid level in master cylinder reservoir and add fluid if necessary (par. 9-7).

3. Check brake pedal for free action, proper return to stop, and proper height (par. 9-8).

4. Pump brake pedal a number of times with quick release. If pedal develops a very solid feel and reduced travel, and brakes drag heavily when drums are turned, it indicates that the compensating port in master cylinder is blocked by a distorted piston primary cup. If brake pedal goes slowly down when steady pressure is applied, and no leaks are found in inspection described later, it indicates a distorted primary cup or scored master cylinder barrel. Either condition requires overhaul of master cylinder (*par. 9-14).

5. Inspect all brake pipe and hose connections for evidence of fluid leakage. See figure 9-4. Tighten any leaking connection, apply heavy pressure to brake pedal to build pressure in hydraulic system, and recheck connections.

6. Remove rear brake drums, and front hub and drum assemblies. **CAUTION:** *Brake pedal must not be operated while drums are removed.*

7. Clean all dirt out of brake drums, using care to avoid getting dirt into front wheel bearings. Inspect drums and replace or recondition if required (*par. 9-12).

8. Inspect front wheel bearings and oil seals. Replace faulty bearings or seals (*par. 7-10).

9. Blow all dirt from brake assemblies, then inspect brake linings for wear, oil soaking, loose rivets, and imbedded foreign particles.

If linings are oil soaked, replacement is required (*par. 9-11).

If linings are worn down to rivets, or the total thickness of lining and shoe rim at thinnest point is less than .180" (measured with ball micrometer), replacement is required (*par. 9-11).

If total thickness of lining and shoe rim is .200" at thinnest point, car owner should be warned that lining replacement will be required in 3000-5000 miles.

10. If linings are otherwise serviceable, tighten or replace loose rivets and thoroughly clean all steel or other imbedded particles from surfaces and rivet counterbores of linings.

11. If brake linings at any wheel show a spotty wear pattern indicating uneven contact with brake drum it is advisable to true up the linings with a light grinding cut, if suitable grinding equipment is available. If brake action was unequal, severe or hard, indicating that brake shoes were not centralized in drums, the grinder may also be used to correct this condition.

Grinding equipment which locates and swings off the wheel spindle or axle shaft may be used to grind shoes concentric with drums, or a bench mounted grinder may be used to grind shoes to the proper radius (.020" less than drum radius). The instructions of equipment manufacturer must be carefully followed.

12. Carefully pull lower edges of wheel cylinder boots away from cylinders and note whether interior is wet with brake fluid. Fluid at this point indicates leakage past the piston cup, requiring overhaul of wheel cylinder (*par. 9-13).

13. Inspect rear brake backing plates for oil leaks past wheel bearing oil seals. Correct any oil leaks by installation of new seals (*par. 6-6).

14. Check all backing plate attaching bolts to make sure they are tight. Check anchor pin nuts for tightness. If an anchor pin nut is found loose, anchor pin must be reset as described later (step 19).

15. Lubricate parking brake cables (par. 9-9). Cables will be adjusted later.

16. If brake shoes were not removed for additional work, pry shoes away from backing plates and clean all rust and dirt from contact surfaces on shoes and plates, using fine emery cloth. Lubricate contact surfaces with a thin

coating of Bendix or Delco Brake Lubricant, or Lubriplate. On rear brakes, sparingly apply the same lubricant to parking brake strut and backing plate boss under the brake cable.

17. Lubricate front wheel bearings, install hub and drum assemblies and adjust wheel bearings (par. 7-10).

18. Install rear brake drums. Remove adjusting hole covers from all backing plates.

19. If brake action was unequal, severe, or hard, it is probable that the shoes were not properly centered in the drums. If grinding equipment is not available for use as specified in Step 11, shoes may be centered in drums by adjusting the anchor pin at each wheel as follows:

(a) Using suitable tool (fig. 9-8) turn brake adjusting screw to expand brake shoes until drum can just be turned with a long bar, giving a drag equivalent to a two-hand drag with wheel installed.

(b) Loosen anchor pin nut $\frac{3}{4}$ of a turn so that pin can shift in slotted hole in backing plate. If nut is loosened too much, the anchor pin will tilt due to pull of brake shoe springs.

(c) Rap backing plate with hammer adjacent to anchor pin to cause pin to shift into central position between ends of brake shoes. Check brake drag with bar and tighten adjusting screw if drag has decreased, rap backing plate, and recheck brake drag.

(d) When anchor pin has been shifted into a central position between ends of shoes as described, *tighten anchor pin nut securely.*

(e) Tightening anchor pin nut should not change the brake drag previously obtained. If it does, repeat the procedure without loosening anchor pin nut quite as much, and tap on anchor pin nut if necessary to shift anchor pin.

20. Install all wheels, turn adjusting screws to provide an equal two-hand drag and adjust shoes for proper clearance as described in paragraph 9-8, (subpar. c).

21. If any hydraulic connections were disturbed or if master cylinder reservoir was pumped dry, bleed hydraulic system at affected wheel cylinders (*par. 9-7). If new parts were installed in brake system, *flushing of hydraulic system is recommended* (*par. 9-7).

22. Adjust parking brake as described in paragraph 9-9 (subpar. a). If car is equipped with a parking brake release warning signal, check its adjustment as described in paragraph 10-51.

23. Remove jacks and road test car for service and parking brake performance (par. 9-5).

9-11 REPLACE OR RELINE BRAKE SHOES

The most satisfactory method of replacing brake lining is to install new shoe and lining assemblies. This insures brake shoes that are not distorted through use, and linings properly riveted to shoes and ground to correct radius by accurate factory machinery.

Each brake shoe and lining set listed under Group 5.017 is packed in a carton containing two primary and two secondary shoe and lining assemblies, enough for two wheels. Sets are available in standard size and also in .030" oversize for use where brake drums have been re-bored.

Use brake shoe lining sets listed under Group 5.018 if the old brake shoes are to be relined. Each lining set is packed in a carton containing two primary and two secondary linings, enough for two wheels. Linings are shaped, drilled, and ground to correct thickness and radius, and are packaged with enough rivets for installation on shoes. Lining sets are available in standard and .030" oversizes.

To assure an adequate supply, several optional types of brake shoe lining have been approved for production and service. Since the optional types of lining have slightly different characteristics it is important to use primary and secondary shoe linings that are matched according to engineering specifications, and to *use the same type of linings on right and left sides* at front or rear end of car. It is not possible to identify the various types of lining by inspection; however, each carton listed under Groups 5.017 and 5.018 contains correctly matched primary and secondary linings. The parts from several different cartons should not be used at one end of a car; however the linings at front and rear brakes do not have to be of the same type.

Brake linings are made of asbestos for its heat resisting qualities and compounds of bonding material for strength. Some bonding materials are used for their lubricating qualities to guard against drum scoring while others are used to control the friction producing property of the lining, called "coefficient of friction." Good molded linings also have imbedded particles of

material used to control friction and wear. When linings are ground, some of the surface particles may be pulled out, giving a pitted appearance. These pits do not affect lining efficiency.

The heat generated by friction will produce different effects in different compounds of bonding material. Some compounds increase friction with increased temperature, which might cause grabbing or locking. Other compounds lose friction with increased temperature, which might cause materially lowered braking power. Brake lining compounds must be carefully selected to produce the braking friction required at the temperatures normally attained in *each vehicle application*.

The linings of all shoes in all series have a radial groove $\frac{3}{8}$ " wide and half the lining thickness in depth. This groove relieves the high pressure area over the web of the shoe to increase the responsiveness of the brakes.

Since the many factors which govern the selection of brake lining vary widely in different vehicle designs, it is impossible to compound one lining which will work satisfactorily on all cars. G.M. engineered brake lining has been selected after exhaustive tests of all types of lining and with complete consideration of all the requirements existant in the various Buick models. The service man does not have the facilities for making similar tests and improving on the selection of lining; therefore *the only safe rule to follow is to use G.M. engineered brake lining*.

a. Removal and Inspection

NOTE: When paragraph references in parentheses () have an asterisk (*) the operation referred to is additional work not covered by the standard replacement operation.

1. Jack up car in a safe manner, remove wheel, then remove brake drum (rear) or drum and hub assembly (front). NOTE: Stops located on the backing plates will prevent pistons from leaving the wheel cylinders; however, brake pedal must not be operated while a brake drum is removed.

2. Unhook shoe return springs from anchor pin, using Brake Spring Remover KMO 526A or large pliers. Remove shoe hold down springs, spread shoes to clear wheel cylinder connecting links, remove parking brake strut (rear only), and remove shoes from backing plate. Disconnect cable from parking brake lever (rear only). See figure 9-10.

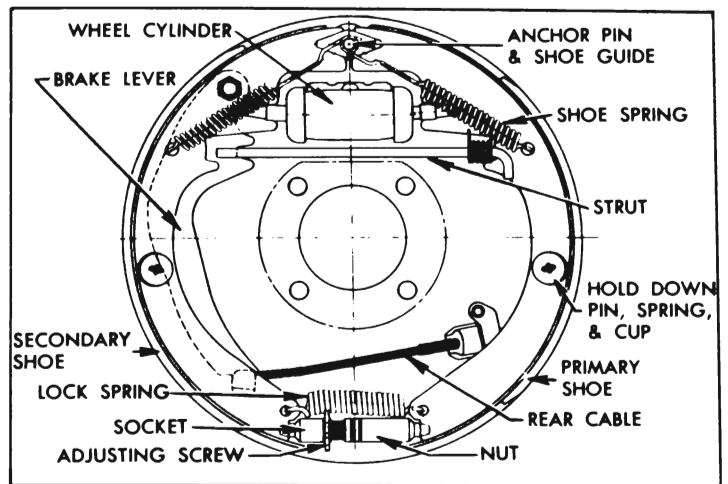

Figure 9-10—Rear Wheel Brake Assembly—Right

3. Separate the brake shoes by removing adjusting screw and lock spring. Remove parking brake lever from secondary brake shoe (rear only). See figure 9-10.

4. Clean all dirt out of brake drum, using care to avoid getting dirt into front wheel bearings. Inspect drums and replace or recondition if required (*par 9-12). If front drum and hub is removed, inspect wheel bearings and oil seal and replace faulty parts (*par. 7-10).

5. Carefully pull lower edges of wheel cylinder boots away from cylinders and note whether interior is wet with brake fluid. Fluid at this point indicates leakage past piston cup, requiring overhaul of wheel cylinder (*par. 9-13).

6. If working at rear wheels, inspect backing plate for oil leak past wheel bearing oil seals. Correct any leak by installation of new seals (*par. 6-6).

7. Check all backing plate attaching bolts to make sure they are tight. Clean all rust and dirt from shoe contact surfaces on plate, using fine emery cloth.

b. Relining Brake Shoes

If old brake shoes are to be relined, inspect shoes for distortion and for looseness between the rim and web; these are causes for discarding any shoe. If shoes are serviceable, be governed by the following points in installing new linings:

1. Remove old linings by drilling out rivets. Punching rivets out will distort shoe rim. Thoroughly clean surface of shoe rim and file off any burrs or high spots.

2. Use only genuine G.M. brake lining and the rivets included in lining package which are of correct size. The rivets must fit the holes and

the solid body of rivet should extend through the shoe rim, but no farther.

3. *Keep hands clean while handling brake lining. Do not permit oil or grease to come in contact with lining.*

4. Start the riveting at center of shoe and lining and work toward the ends. Use a roll set for riveting; a star set might split the tubular end and then the rivet would not fill the hole. The primary lining is shorter than secondary lining, therefore the rivet holes at each end of shoe rim are not used.

5. After riveting is completed, lining must seat snugly against shoe with no more than .005" separation midway between rivets. Check with a .004" (permissible) and a .006" (no go) feeler gauge.

c. Installation and Adjustment

1. If working on rear brakes, lubricate parking brake cable (par. 9-9).

2. On rear brakes only, lubricate fulcrum end of parking brake lever and the bolt with Bendix or Delco Brake Lubricant, or Lubriplate, then attach lever to secondary shoe with bolt, spring washer, nut, and Pal nut. Make sure that lever is free moving. See figure 9-10.

3. Connect brake shoes together with lock spring, then place adjusting screw, socket, and nut in position. The socket and star wheel must be adjacent to primary shoe on left brakes, and adjacent to secondary shoe on right brakes.

4. Lubricate shoe contact surfaces with a thin coating of Bendix or Delco Brake Lubricant, or Lubriplate. On rear brakes, sparingly apply same lubricant where brake cable contacts backing plate.

5. Attach brake shoes to backing plate with hold down springs, pins, and cups, at the same time engaging shoes with wheel cylinder connecting links. The primary shoe (short lining) goes forward. On rear brakes, connect cable to parking brake lever and install strut between lever and primary shoe as installation is made. See figure 9-10.

6. If old brake shoe return springs are nicked, distorted, or of doubtful strength it is advisable to install new ones. Hook springs in shoes and over end of anchor pin, using KMO 526A or large pliers and being careful not to nick or distort springs.

7. Install brake drum and wheel. If working on front brake lubricate and adjust front wheel

bearings (par. 7-10). Remove adjusting hole cover from backing plate.

8. Centralize brake shoes and set anchor pin, then adjust all brake shoes and brake cable as described in paragraph 9-10, steps 17 through 22.

IMPORTANT: *Brakes must not be severely applied immediately after installation of new brake shoes or linings. Severe application may permanently injure new linings and may score brake drums. When linings are new they must be given moderate use for several days until nicely burnished.*

9-12 INSPECTING AND RECONDITIONING BRAKE DRUMS

Whenever brake drums are removed they should be thoroughly cleaned and inspected for cracks, scores, deep grooves, and out-of-round. Any of these conditions must be corrected since they can impair the efficiency of brake operation and also can cause premature failure of other parts.

a. Cracked, Scored, or Grooved Drum

A cracked drum is unsafe for further service and must be replaced. Welding a cracked drum is not recommended.

Smooth up any slight scores by polishing with fine emery cloth. Heavy or extensive scoring will cause excessive brake lining wear and it will probably be necessary to rebore in order to true up the braking surface.

If the brake linings are little worn and drum is grooved, the drum should be rebored just enough to remove grooves, and the ridges in the lining should be lightly removed with a lining grinder.

If brake linings are more than half worn, but do not need replacement, the drum should be polished with fine emery cloth but should not be rebored. At this stage, eliminating the grooves in drum and smoothing the ridges on lining would necessitate removal of too much metal and lining, while if left alone, the grooves and ridges match and satisfactory service can be obtained.

If brake linings are to be replaced, a grooved drum should be rebored for use with oversize linings (subpar. c, below). A grooved drum, if used with new lining, will not only wear the lining but will make it difficult, if not impossible, to obtain efficient brake performance.

b. Out-of-round or Tapered Drum

An out-of-round drum makes accurate brake shoe adjustment impossible and is likely to cause excessive wear of other parts of brake mechanism due to its eccentric action. An out-of-round drum can also cause severe and very irregular tire tread wear.

A drum that is more than .010" out-of-round on the diameter is unfit for service and should be rebored (subpar. c, below). A drum that has more than .005" taper should be rebored. Out-of-round as well as taper and wear can be accurately measured with an inside micrometer fitted with proper extension rods.

When measuring a drum for out-of-round, taper, and wear, take measurements at the open and closed edges of machined surface and at right angles to each other. Standard drums are machined to an inside diameter of 12.010" to 12.020", with runout of braking surface held within .005" total indicator reading.

c. Reboring Brake Drum

If a drum is to be rebored, enough metal should be removed to obtain a true, smooth braking surface. If a drum does not clean-up when rebored to a diameter of 12.080", it must be replaced. Removal of more metal will affect dissipation of heat and may cause distortion of the drum.

A newly bored drum should always have center contact with the shoes on initial break-in, thus insuring greater uniformity in brake performance with less danger of brake pulling. To get this desired position, the shoe radius should always be .010" less than the drum radius (or .020" less on the diameter). This fit may be accomplished by either grinding the shoes or boring the drums, whichever is the more practical.

If cleaning-up a drum required boring to a size too large to accomplish this fit (shoe radius .010" less than drum radius) using standard size brake lining, then .030" oversize lining must be used.

Fit between the brake shoes and the drum must always be the same on both sides of the car to get equal braking action.

Brake drums may be refinished either by turning or grinding. Best brake performance is obtained by turning drums with a very fine feed. Ground and polished drums do not wear in as readily as turned drums and are more likely to cause unequal braking when new. To

insure maximum lining life, the refinished braking surface must be smooth and free from chatter or tool marks.

Run-out of the refinished surface of brake drum must not exceed .005" total indicator reading. Run-out (sideways wobble) of the open edge of drum must not exceed .030".

d. Brake Drum Balance

During manufacture, brake drums are balanced within 3 inch ounces by fastening weights, as required, near the rim. These weights must not be removed.

After drums are rebored, or if difficulty is experienced in maintaining proper wheel balance, it is recommended that brake drums be checked for static balance. Drums out of balance more than 3 inch ounces may be corrected by installation of service balance weights. Brake drums may be checked for balance on any machine suitable for balancing wheels.

9-13 BRAKE WHEEL CYLINDER OVERHAUL

1. Remove wheel, drum, and brake shoes. Be careful not to get grease or dirt on brake lining.
2. Disconnect brake pipe or hose from wheel cylinder and cover opening with tape to prevent entrance of dirt. Remove wheel cylinder from backing plate.
3. Remove links, boots, pistons, cups, cup expanders and spring from cylinder. Remove bleeder valve.
4. Discard rubber boots, expander assembly, and piston cups. Thoroughly clean all other parts with hydraulic brake fluid or a good grade of alcohol. CAUTION: *Do not use anti-freeze alcohol, gasoline, kerosene, or any other cleaning fluid that might contain even a trace of mineral oil.*
5. Inspect pistons and cylinder bore for scores, scratches, or corrosion. Light scratches may be polished with crocus cloth. *Do not use emery cloth or sandpaper.* Slight corrosion may be cleaned with fine steel wool and alcohol. If scratches or corroded spots are too deep to be polished satisfactorily the cylinder should be replaced since honing is not recommended.
6. Dip internal parts in brake fluid and re-assemble wheel cylinder. When installing piston cups use care to avoid damaging the edges.

NOTE: *Front wheel cylinder pistons and cups are 1 1/8" diameter and rear wheel cylinder parts are 1" diameter.*

7. Install wheel cylinder on brake backing plate and connect brake pipe or hose.

8. Install brake shoes, drum, and wheel, then flush and bleed hydraulic system (par. 9-7).

9. Adjust brakes (par. 9-8) then road test car for brake performance (par. 9-5 and 9-6).

9-14 BRAKE MASTER CYLINDER OVERHAUL

a. Removal of Brake Master Cylinder

1. Remove clevis pin and spring washer from push rod clevis.

2. Disconnect brake pipe from master cylinder and tape end of pipe to prevent entrance of dirt.

3. Remove bolts holding master cylinder and dash reinforcement to dash panel and remove cylinder from car.

4. Clean outside of master cylinder thoroughly. Remove filler cap, turn cylinder over, and pump push rod by hand to drain all brake fluid. *Always discard used fluid.*

b. Disassembly of Brake Master Cylinder

1. Remove rubber boot. Remove lock ring, then remove push rod and clevis with stop plate. See Figure 9-11.

2. Remove piston with secondary cup, primary cup, spring, check valve, and valve seat washer.

3. Discard boot, lock ring, piston and rubber cups, spring, check valve, and valve seat washer. These parts are furnished in the master cylinder repair kit (Group 4.649).

4. Remove filler cap and gasket. Thoroughly clean master cylinder with alcohol. CAUTION: *Do not use anti-freeze alcohol, gasoline, kerosene, or any other cleaning fluid that might contain even a trace of mineral oil.*

c. Inspection of Brake Master Cylinder

Inspect cylinder bore for scores, scratches, or corrosion. Light scratches in cylinder bore may be polished with crocus cloth. *Do not use emery cloth or sandpaper.* Slight corrosion may be cleaned with fine steel wool and alcohol.

If scratches or corroded spots are too deep to be polished satisfactorily the cylinder should be replaced since honing is not recommended and oversize pistons and cups are not furnished for service.

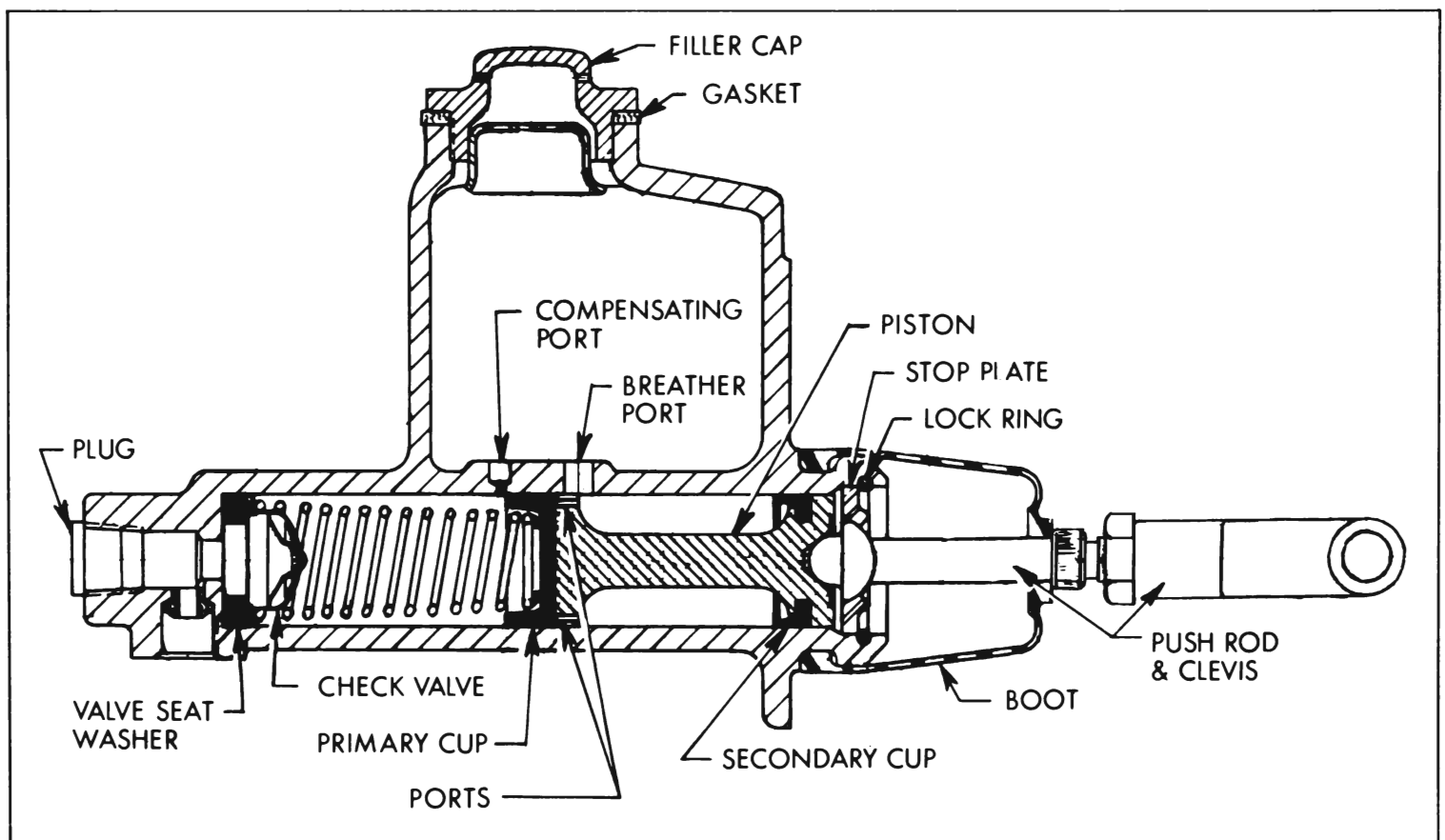

Figure 9-11—Standard Brake Master Cylinder

Wheel and master cylinder bores have a hard, highly polished "bearingized" surface produced by diamond boring followed by rolling under very heavy pressure. Honing destroys the bearingized surface, leaving a softer and rougher surface which will cause more rapid wear of pistons and rubber cups. Higher friction produced by the rougher surface will also reduce braking power for a given pressure on brake pedal.

The maximum allowable clearance between piston and cylinder bore is .0055". If this clearance is increased by honing, the heavy pressure of brake fluid may force rubber of the cup into the clearance and cause sticking or early failure of the cup. If a choice must be made between honing or replacement of the cylinder, it must be remembered that while a new cylinder may be more expensive a honed cylinder may not give satisfactory length of service.

Make certain that compensating port in cylinder is clear; however, do not run a wire through port as this may result in leaving a burr which will cut a groove in primary cup.

d. Assembly of Brake Master Cylinder

1. Dip all internal parts in clean brake fluid

just before installation. Also wet master cylinder bore with brake fluid.

2. Install valve seat washer, check valve, spring, primary cup, and piston with secondary cup. Then install push rod and stop plate assembly. Hold push rod in and install lock ring. *Check for proper seating of lock ring with a hard pull on push rod.*

3. Install rubber boot. Check filler cap holes to make sure they are clear, then install cap and gasket finger tight.

e. Installation of Brake Master Cylinder

1. Bolt master cylinder and dash reinforcement to dash panel. Torque bolts to 30 foot pounds.

2. Connect brake pipe to master cylinder.

3. Connect push rod clevis to brake pedal by installing clevis pin and spring washer.

4. Check brake pedal for correct height as described in paragraph 9-8 (b). Adjust pedal height if necessary.

5. Bleed hydraulic system as described in paragraph 9-7. After bleeding, bring fluid level to 1/2"-1" below lip of filler opening.

6. Road test car for proper brake performance (par. 9-5).