

SECTION 13-D HEADLINING AND SEATS

CONTENTS OF SECTION 13-D

Paragraph	Subject	Page	Paragraph	Subject	Page
13-13	Headlining	13-35	13-14	Seats	13-37

13-13 HEADLINING

The headlining assembly is formed to contour by concealed listing wires. Both ends of each listing wire are installed into holes in listing wire clips which are secured to the side roof inner rail assembly. The headlining assembly is secured at the windshield and back window by cement and tacks or staples. Along the side roof rail, the headlining is cemented around the flange of the side roof inner rail assembly.

CAUTION: Clean hands and tools are essential when working with headlining material.

a. Removal of Headlining

1. Place protective coverings over seat cushions and backs.
2. Prior to removing headlining, remove following hardware and trim assemblies:
 - a. Sunshade support assembly(s)
 - b. Rear view mirror support
 - c. Windshield upper garnish moldings
 - d. Center pillar-to-roof rail finishing plates
 - e. Coat hooks (where present)
 - f. Back window upper garnish moldings, right, left and center
 - g. Dome lamp assembly
 - h. Front and rear door opening pinchweld finishing strip along top of each door opening sufficiently to expose edge of headlining
 - i. Body lock pillar to roof rail finishing plates (station wagon only)
 - j. Back body opening upper finishing panels (station wagon only)
 - k. Rear quarter upper pinchweld finishing strips (station wagon only)

3. Carefully detach cemented edge of headlining along each side roof inner rail including rear quarter windows on station wagon styles. See view "A", Figure 13-56.

4. Carefully remove tacks or staples securing headlining at windshield opening as shown in View "A" and along back window or back body opening as shown in Views "B" and "C", Figure 13-56, then carefully detach cemented edges of headlining from openings.

5. Working from front to rear of body, disengage headlining #1 listing wire from clip on side roof inner rail. Gather or roll headlining with listing wires on outside to keep headlining clean.

6. At roof bow, bend down metal tabs, shown in View "E", Figure 13-56, and remove listing support wire from roof bow.

7. Disengage remaining listing wires from clips on side roof inner rail and remove headlining from body and place on clean protected surface.

IMPORTANT: Note which holes the ends of the listing wires are installed in side roof rail clips to insure proper installation (see View "B").

8. If replacing the headlining, remove listing wires from pockets of headlining.

b. Installation of Headlining

1. If previously removed, install listing wires into pockets of new headlining assembly.

2. Apply approved trim cement to headlining attaching surfaces at windshield and back window openings. Also apply cement to headlining attaching surfaces along side roof inner rails.

3. Lift entire headlining assembly into body, then install rear listing wire. Center and align headlining in relation to back window opening and side roof rails. Working forward,

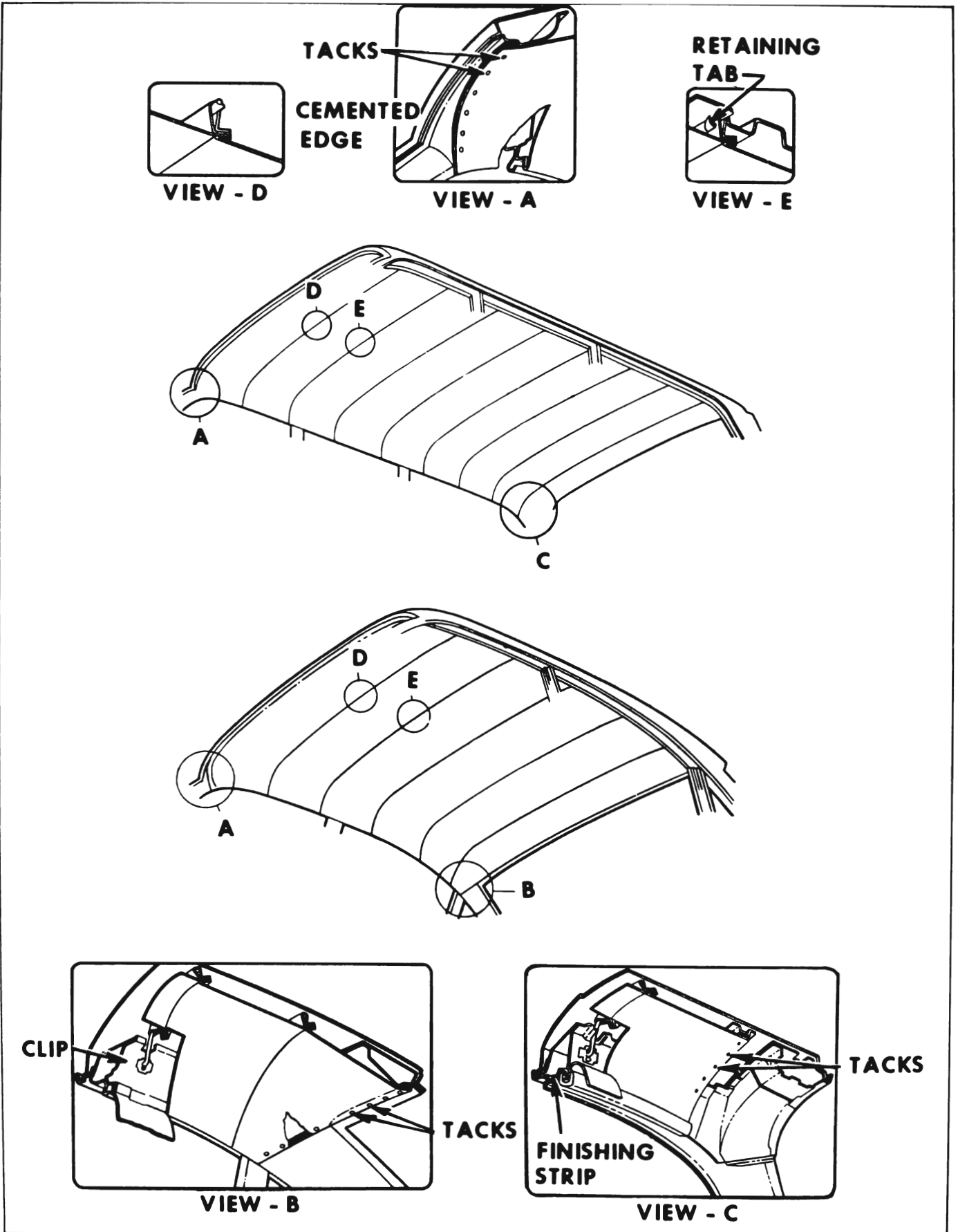

Figure 13-56—Headlining Installation

install ends of listing wires into listing wire holes in side roof rails.

NOTE: The headlining listing wires are normally installed in center hole of clip as shown in View "B".

4. Install headlining listing support wire over metal tabs on roof bow. Bend up metal tabs so that support wire is securely fastened to roof bow. See View "E", Figure 13-56.

5. Install #1 listing wire into hole of clip on side roof inner rail.

NOTE: Headlining listing wires may be adjusted up or down in different clip holes as required to compensate for a headlining which may be too tight against the roof panel or too loose, making it difficult to remove draws or wrinkles.

6. Stretch and stay tack headlining along entire windshield and back window openings.

7. Apply trim cement to side edges of headlining assembly.

8. Working toward front of body, install headlining to side roof inner rail, cutting headlining to shape at center pillar and upper rear body lock pillar. Remove all draws or wrinkles as required from headlining assembly.

9. Trim excess material from edges of headlining assembly.

10. Using a headlining inserting tool, install trimmed edges of headlining to outer surface of side roof inner rail to give headlining a finished appearance.

11. Inspect headlining along back window opening. Remove draws or wrinkles as required by stretching material and retacking. After all fullness has been removed, permanently tack headlining assembly across back window opening.

12. Trim away excess material across back window opening.

13. Inspect headlining along windshield opening. Remove draws or wrinkles as required by stretching material and retacking. After all fullness has been removed, permanently tack headlining assembly across windshield opening.

14. Trim away excess material across windshield opening.

15. Install door opening and/or rear quarter upper pinchweld finishing strips and all other previously removed inside hardware.

13-14 SEATS

Manually operated front seat adjusters provide fore and aft movement of the seat. When the lever at the left seat adjuster is raised the seat adjusters unlock, permitting horizontal travel of the seat. When the seat is in the desired position, the lever is released and the seat is locked.

The front seat adjusters may be reworked to reposition the front seat assembly one (1) inch rearward.

a. Removal and Installation of Front Seat Assembly With Seat Adjusters Attached

1. Turn back floor carpeting where necessary, to expose seat adjuster-to-seat support attaching bolts.

2. Scribe location of rear end of adjuster on front seat rear support and remove adjuster rear attaching bolts.

3. With aid of helper, tilt seat assembly forward; then slide seat assembly rearward to disengage front legs of adjusters from retainers. Remove seat assembly from body.

4. To install, reverse removal procedure.

NOTE: Make certain front legs of adjusters are completely engaged under retainers and adjusters are aligned within scribe marks before installing attaching bolts.

b. Removal and Installation of Front Seat Adjusters

1. Remove front seat assembly with adjusters attached from body and place it upside down on a clean, protected bench.

2. Remove seat adjuster counter balance spring attached to seat adjuster front support and seat bottom frame as shown in Figure 13-57.

3. Operate adjusters so that both front and rear attaching bolts are accessible.

4. Squeeze hooked end of seat adjuster locking wire together and slide retaining spring back over hump in locking wire and remove locking wire from adjuster.

5. Remove adjuster-to-seat bottom frame front and rear attaching bolts shown in Figure 13-57 and remove seat adjuster from seat assembly.

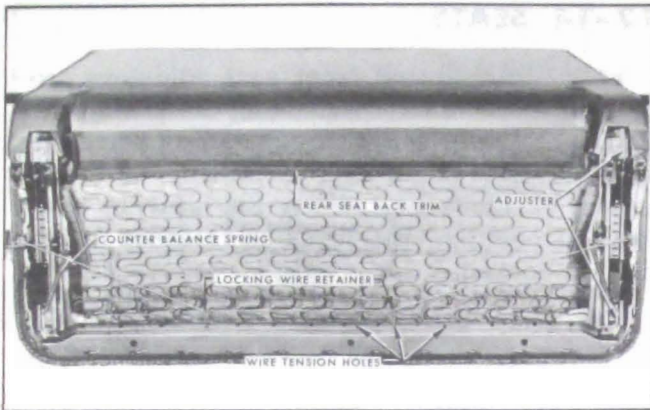

Figure 13-57 — Front Seat Adjuster

6. To install, reverse removal procedure. Check seat assembly for proper operation prior to installing seat assembly.

NOTE: The right and left seat adjuster sliding mechanisms should be in same relative position when attaching adjuster to seat bottom frame.

7. If right adjuster does not lock or unlock satisfactorily when control handle on left adjuster is operated, disengage locking wire retainer on right side of seat from hole in seat bottom frame and engage retainer in one of adjacent holes to obtain proper tension in wire. See Figure 13-57.

c. Removal and Installation of Front Seat Back Assembly

1. Remove front seat assembly from body and place it upside down on a clean, protected bench.

2. Remove hog rings securing central portion of lower rear edge of seat back trim from front seat cushion spring assembly. See Figure 13-57.

3. Raise trim and remove cardboard break-over foundation to expose seat cushion spring

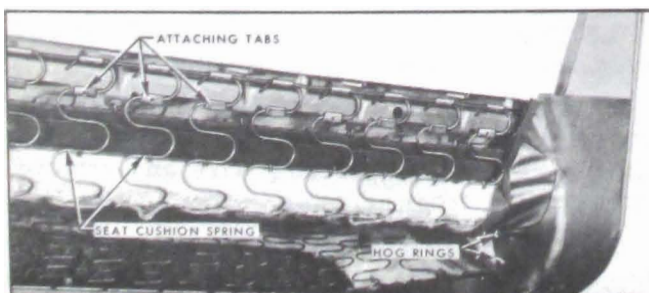

Figure 13-58 — Front Seat Cushion Spring Attachment

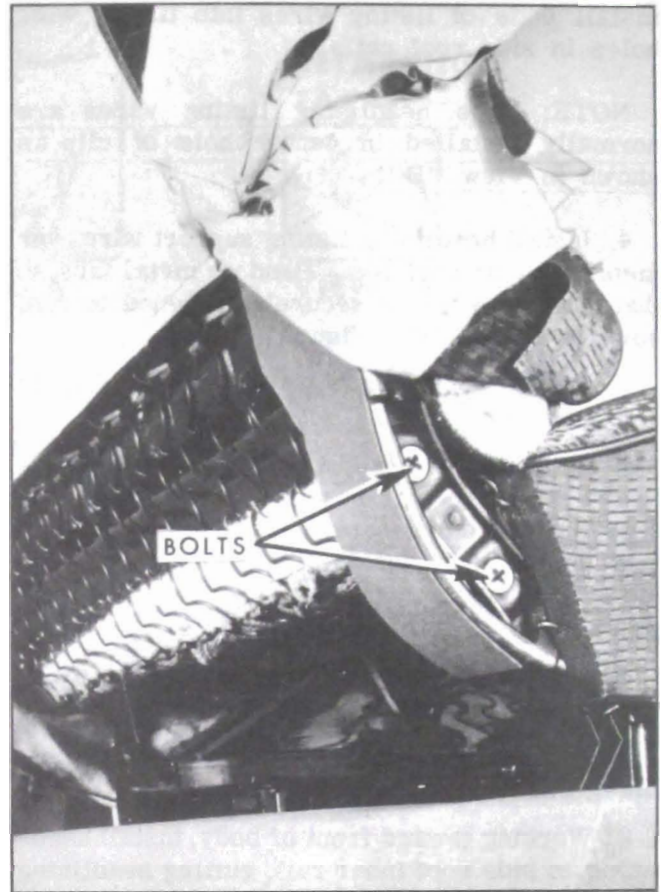

Figure 13-59 — Front Seat Back Attachment

attachment to seat back frame along rear of seat and hog rings securing ends of seat back trim to seat bottom frame. See Figure 13-58.

4. Bend open tabs securing seat cushion spring assembly to seat back frame and carefully disengage springs from tabs. See Figure 13-58.

5. At each end of seat remove hog rings securing lower edge of seat back trim from seat bottom frame. Then raise seat back trim to expose bolts securing seat back reinforcement to seat bottom frame. See Figure 13-59.

6. Place seat assembly in upright position. Then with a helper, holding seat back assembly, remove seat back reinforcement-to-seat bottom frame attaching bolts on each side of seat and remove seat back assembly.

7. To install, reverse removal procedure.

NOTE: Make certain rear edge of seat cushion spring assembly is properly engaged to seat back frame and cardboard breakover foundation is properly positioned prior to hog ringing central portion of trim in place.

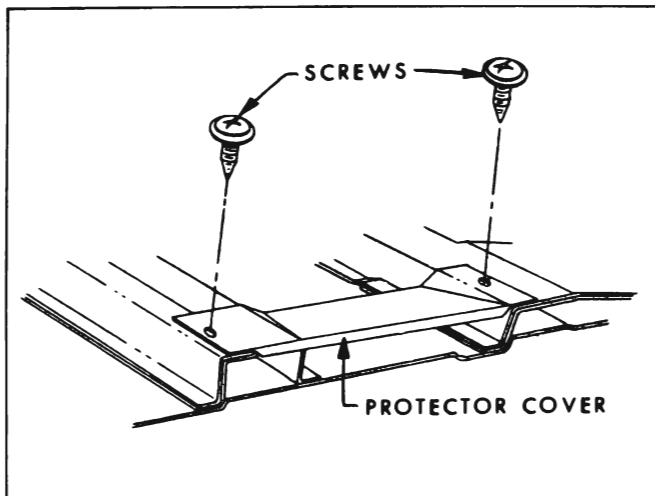

Figure 13-60 — Front Seat Side Protector Cover

d. Removal and Installation of Front Seat Side Protector Cover

1. Turn back floor covering along outboard side of front seat adjuster sufficiently to expose protector cover.
2. Remove screws shown in Figure 13-60 securing cover to floor pan and remove cover.
3. To install, reverse removal procedure.

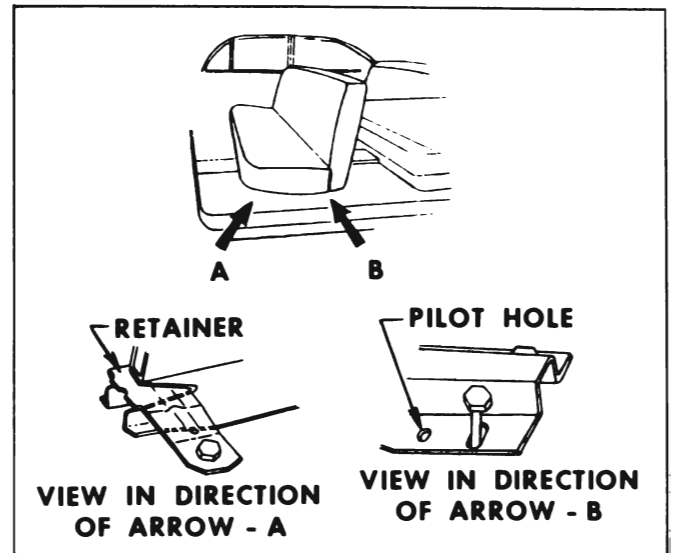

Figure 13-61 — Front Seat Repositioning

e. Repositioning Front Seat Assembly

To reposition front seat assembly one (1) inch rearward, proceed as follows:

1. Remove front seat assembly from body and place it upside down on a clean protected bench.

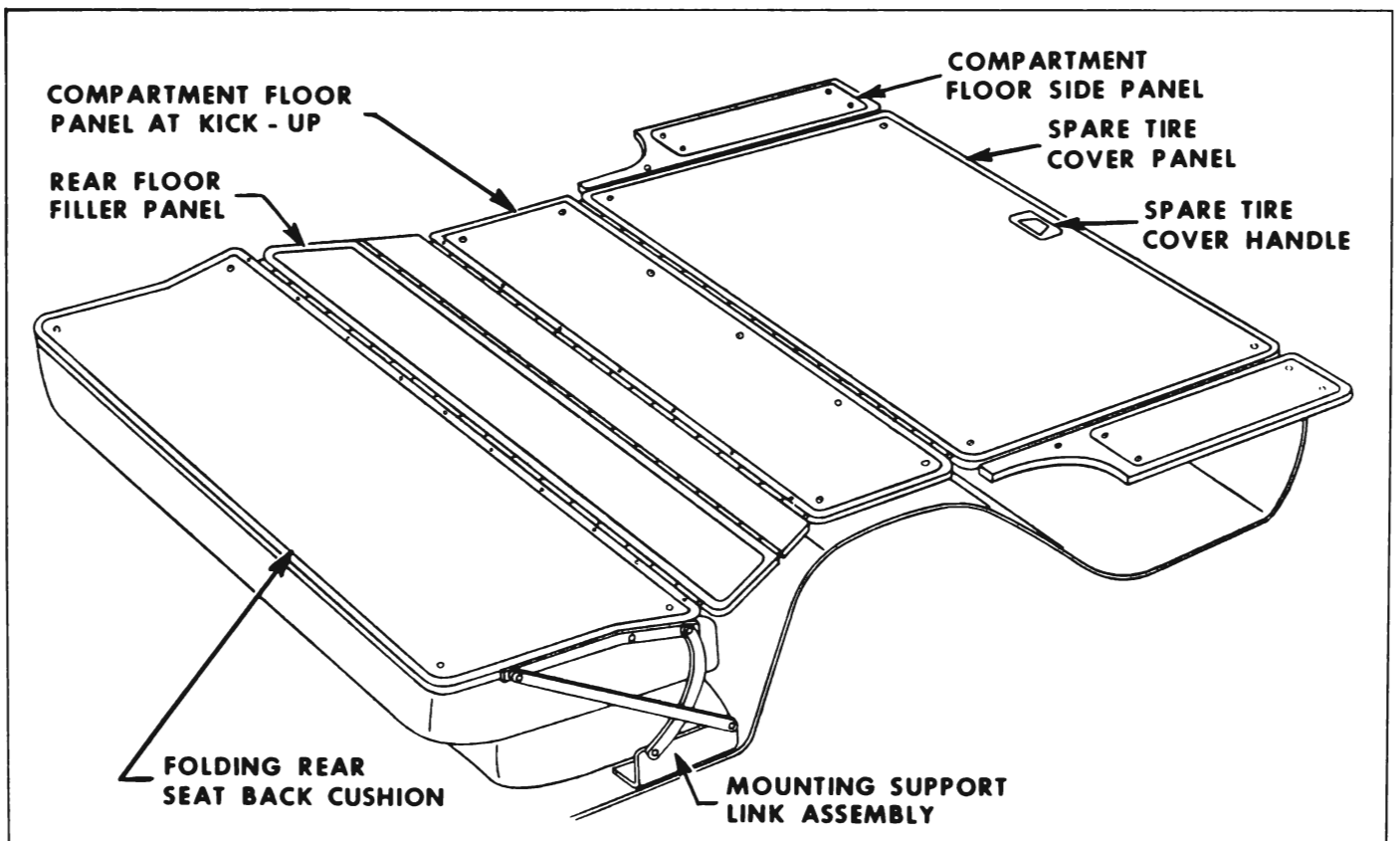

Figure 13-62 — Folding Rear Seat Back and Rear Compartment Floor Panel

2. Remove seat adjuster retainers from front seat floor pan support.
3. Turn seat adjuster retainer 180° and install retainer.
4. Enlarge pilot holes in seat adjuster located one (1) inch forward of attaching holes at rear of each seat adjuster to 3/8" diameter. See Figure 13-61.
5. Install front seat assembly. Check seat for proper operation.

f. Removal and Installation of Folding Rear Seat Cushion (4035 and 4135 Styles)

1. Lift up front edge of folding rear seat cushion assembly to disengage protrusions in seat bottom frame from slots in rear seat support and remove cushion assembly.
2. To install, reverse removal procedure. Make certain that protrusions are fully engaged in rear seat support.

g. Removal and Installation of Folding Rear Seat Back Assembly (4035 and 4135 Styles)

1. Fold rear seat back assembly to down position.
2. Remove rear floor filler panel to folding seat back panel attaching screws as shown in Figure 13-63.
3. At each side of seat, remove screws securing mounting support link assembly to folding seat back assembly. See Figure 13-64.

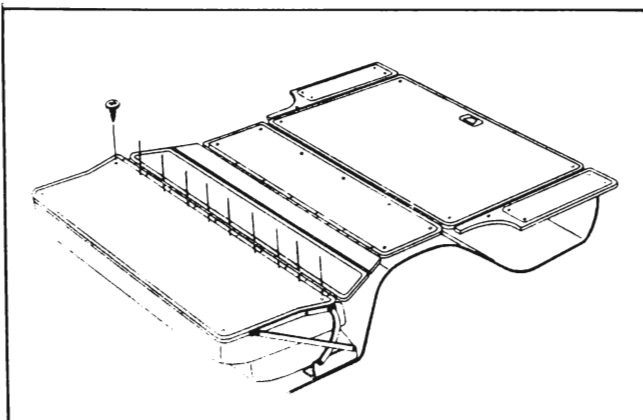

Figure 13-63 — Folding Rear Seat Back Assembly

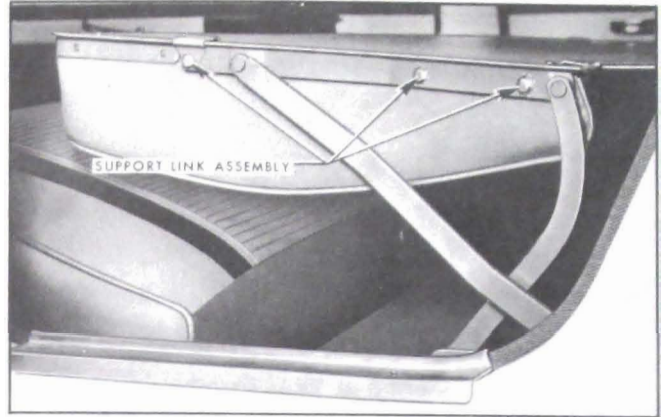

Figure 13-64 — Folding Seat Back Mounting Support Link Assembly

4. With aid of helper, carefully remove folding seat back assembly from body and place it on clean, protected bench.
5. To install, reverse removal procedure.

h. Removal and Installation of Folding Rear Seat Back Mounting Support Link Assembly (4035 and 4135 Styles)

1. Release rear seat cushion and slide cushion forward.
2. Turn back rear floor carpet sufficiently to expose mounting support link to floor pan anchor plate attaching screws and remove screws.
3. Fold rear seat back assembly to down position.
4. Remove mounting support to folding seat back attaching screws as shown in Figure 13-64 and remove mounting support link assembly from body.
5. To install, reverse removal procedure. Check operation of folding rear seat back and filler panel assembly. Where required, loosen mounting support to anchor plate attaching screws. Adjust mounting support fore or aft as required for proper folding seat back operation.

i. Removal and Installation of Folding Rear Floor Filler Panel Assembly (4035 and 4135 Styles)

1. Fold rear seat back assembly to down position.

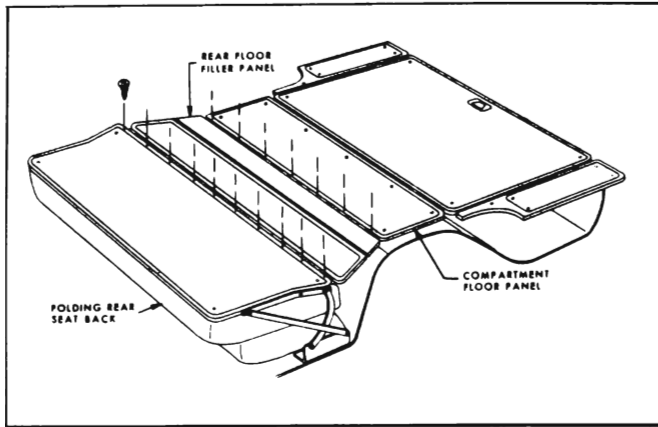

Figure 13-65 — Folding Rear Floor Filler Panel Assembly

2. Remove filler panel to folding seat back attaching screws and filler panel to rear seat pan attaching screws as shown in Figure 13-65 and remove filler panel from body.

4. To install, reverse removal procedure.

j. Adjustment of Folding Rear Floor Filler Panel Assembly (4035 and 4135 Styles)

To adjust folding rear floor filler panel assembly, proceed as follows:

1. At each side of seat, loosen mounting support to floor pan anchor plate attaching screws.

2. Adjust mounting supports fore or aft as required and tighten screws.

3. Check operation of folding seat back and filler panel assembly. When the seat back is in the "down" or folded position, the back and rear floor filler panel should form a level floor surface. Where necessary, readjust mounting supports as required for proper seat back and filler panel operation.

k. Removal and Installation of Compartment Floor Panel Assembly (At Kick-up) (4035 and 4135 Styles)

1. Lower folding rear seat back assembly.

2. Remove rear floor filler panel to rear seat pan attaching screws as shown at "A" in Figure 13-66.

3. Fold rear floor filler panel forward sufficiently to gain access to compartment floor

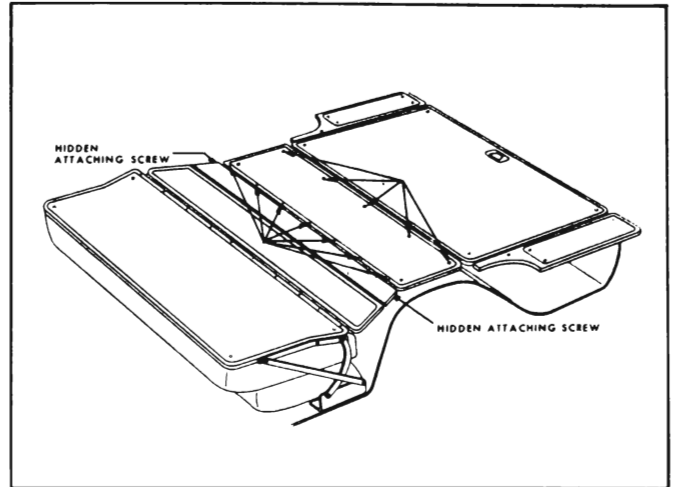

Figure 13-66 — Compartment Floor Panel Assembly

panel to rear seat pan attaching screws and remove screws from panel.

NOTE: Attaching screws are located at each end of panel (see "Hidden Attaching Screw", Figure 13-66).

4. Remove floor panel to spare tire cover hinge support panel attaching screws, shown at "B", Figure 13-66, and remove compartment floor panel assembly from body.

5. To install, reverse removal procedure.

l. Removal and Installation of Spare Tire Cover Panel Assembly (4035 and 4135 Styles)

1. Remove compartment floor panel assembly as previously described.

2. Remove screws securing spare tire cover panel hinge to hinge support.

3. Using spare tire cover handle, lift panel upward and remove spare tire cover panel assembly from body.

4. To install, reverse removal procedure.

m. Removal and Installation of Compartment Floor Side Panel Assembly (Right or Left Side) (4035 and 4135 Styles)

1. Remove compartment floor panel assembly as previously described.

2. Remove screws securing compartment floor side panel to side panel support as shown at "A", Figure 13-67, and remove panel assembly from body.

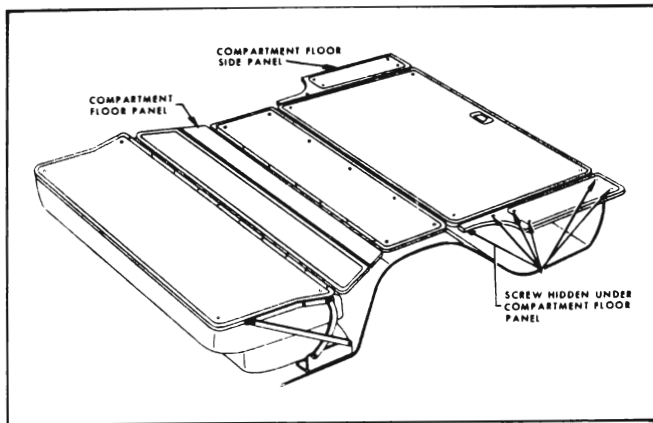

Figure 13-67 — Compartment Floor Side Panel Assembly

3. To install, reverse removal procedure.

n. Removal and Installation of Folding Rear Seat Back Bumper, Retainer and Support (Right or Left Side) (4035 and 4135 Styles)

1. With folding rear seat back in down position, remove screw shown in View "A", Figure 13-68, and remove bumper and retainer from wheelhouse support.

2. Remove three (3) screws shown in View "A", Figure 13-68, and remove support from wheelhouse assembly.

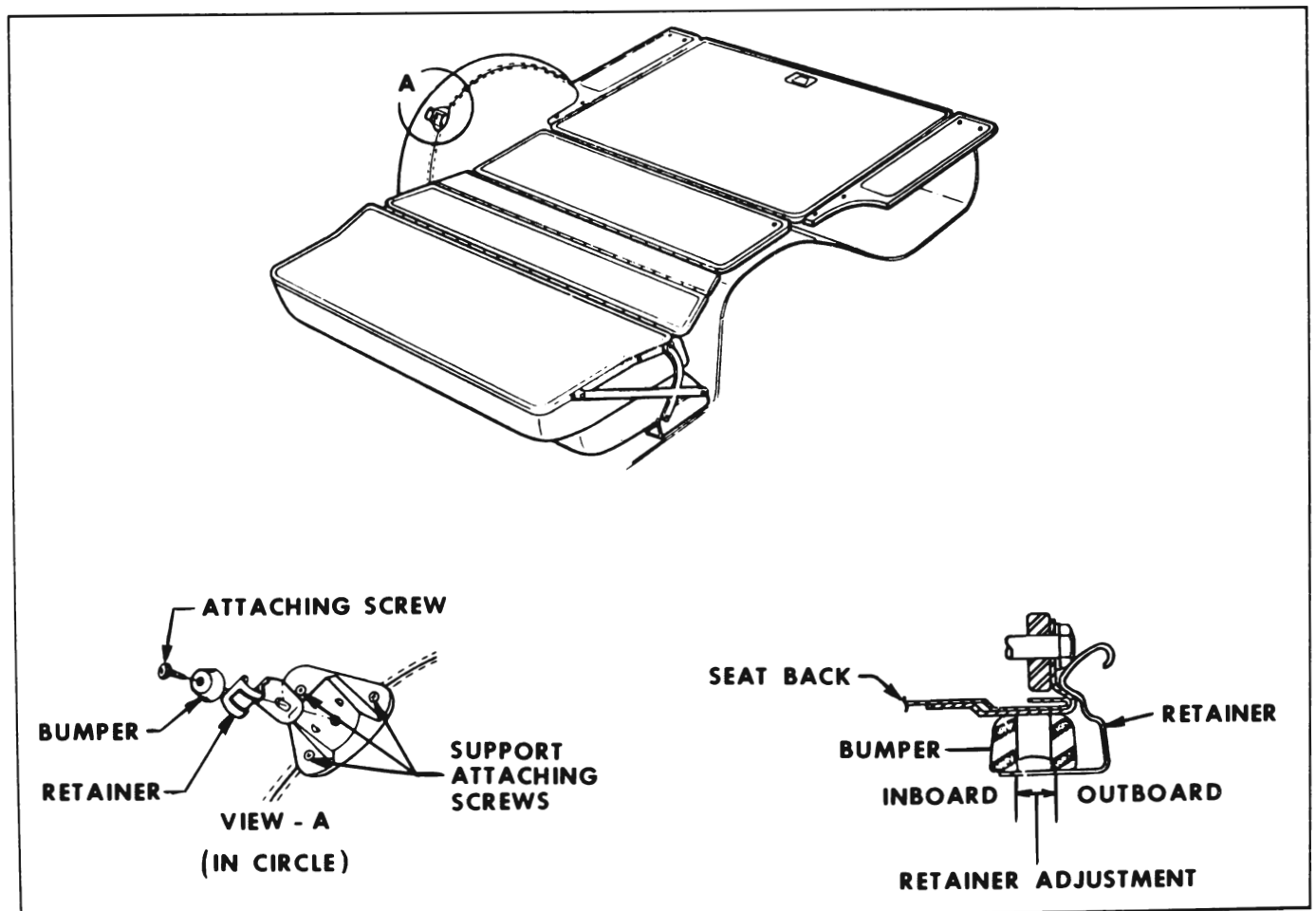

Figure 13-68 — Folding Rear Seat Back Bumper, Retainer and Support

3. To install, reverse removal procedure.

NOTE: The folding rear seat back retainer is adjustable inboard or outboard. See Figure 13-68. To adjust retainer, raise folding rear seat back to up position and check retainer tension. Lower folding seat back and loosen retainer attaching screw. Adjust retainer inboard or outboard as required, then tighten attaching screw. Recheck folding seat back assembly. Where required, readjust retainer until

desired seat back retention has been obtained.

**o. Removal and Installation of
Spare Tire Cover Handle Assembly
(4035 and 4135 Styles)**

1. Remove four (4) screws securing handle to spare tire cover panel and remove handle assembly from panel.

2. To install, reverse removal procedure.