

## SECTION 8-B ROTARY VALVE POWER STEERING GEAR AND PUMP

### CONTENTS OF SECTION 8-B

Paragraph	Subject	Page	Paragraph	Subject	Page
8-8	Rotary Valve Power Steering Gear & Pump Specifications . . . . .	8-12	8-14	Disassembly, Inspection & Assembly of Adjuster Plug Assembly & Rotary Valve Assembly . . . . .	8-33
8-9	Description of Rotary Valve Power Steering Gear and Pump . . . . .	8-13	8-15	Disassembly, Inspection & Assembly of Pitman Shaft Assembly . . . . .	8-38
8-10	Operation of Rotary Valve Power Steering Gear . . .	8-19	8-16	Disassembly, Inspection & Assembly of Rack-Piston Nut & Worm Assembly . .	8-40
8-11	Trouble Diagnosis-Power Steering Gear and Pump .	8-22	8-17	Disassembly, Inspection & Assembly of Oil Pump . .	8-43
8-12	Removal and Installation of Pitman Shaft Seals, Steering Gear & Oil Pump . .	8-27	8-18	Removal and Installation of Mast Jacket Assembly . . . . .	8-47
8-13	Adjustment of Power Steering Gear and Linkage . .	8-30			

### 8-8 ROTARY VALVE POWER STEERING GEAR AND PUMP SPECIFICATIONS

#### a. Tightening Specifications

Use a reliable torque wrench to tighten the

parts listed to insure proper tightness without straining or distorting parts. These specifications are for clean and lightly lubricated threads only; dry or dirty threads produce increased friction which prevents accurate measurement of tightness.

Part	Location	Thread Size	Torque Ft. Lbs.
Bolt	Lower Coupling Flange Pinch . . . . .	3/8 -24	20-35
Bolt	Gear Side Cover to Housing . . . . .	3/8 -16	30-35
Nut	Pump Front & Rear Mounting Brackets to Pump . . . . .	3/8 -16	25-35
Bolt	Pump Front Mounting Bracket to Cylinder Block . . . . .	5/16-18	20-25
Bolt	Pump Front Mounting Bracket to Timing Chain Cover . . . . .	3/8 -16	25-35
Bolt	Pump Rear Mounting Bracket to Cylinder Head . . . . .	3/8 -16	25-35
Bolt & Nut	Pump Rear Mounting Bracket to Cylinder Block . . . . .	3/8 -16	25-35
Stud & Bolt	Pump Reservoir to Housing . . . . .	3/8 -16	25-30
Bolt & Nut	Gear Housing to Front Suspension Cross Member . . . . .	7/16-20	45-60
Union	Pump Pressure Outlet . . . . .	5/8 -18	15-20
Nut	Steering Wheel to Steering Shaft . . . . .	5/8 -18	20-30
Nut	Pitman Arm to Pitman Shaft . . . . .	3/4 -16	90-110
Nut	Pulley to Pump Shaft . . . . .	9/16-18	40-45
Nut	Lash Adjuster Lock . . . . .	7/16-20	25-35
Bolt & Nut	Lower Coupling to Steering Shaft Flange . . . . .	5/16-24	15-20

#### b. Steering Gear Specifications

	Specifications
Gear Type . . . . .	Recirculating Ball Nut and Worm
Make . . . . .	Saginaw
Ratio, Gear Only . . . . .	17.5 to 1
Ratio, Overall (Including Linkage) . . . . .	20.8 to 1
Steering Wheel Diameter . . . . .	17"
Effort Necessary at Wheel Rim for Initial Hydraulic Assist . . . . .	Approx. 1 lb.
Effort Necessary at Wheel Rim for Full Hydraulic Assist . . . . .	Approx. 3 1/4 lbs.
Turns of Steering Wheel, Left to Right (gear connected) . . . . .	4
Steering System Oil . . . . .	Hydraulic Steering Oil or Automatic Transmission Oil

Steering System Oil Capacity (Dry) . . . . .	1 qt.
Worm and Rack - Piston Nut Balls - No. and Diameter . . . . .	11 Black, 11 Plain, 6 Sizes Plain
	From .28117 (Code No. 6) to .28157 (Code No. 11) by .00008th

**Adjustments****Thrust Bearing Preload (Including Valve Assembly Drag)**

Torque at Stub or Steering Shaft . . . . .	2 to 11 in. lbs.
Lbs. Pull at Steering Wheel Rim . . . . .	1/4 to 1 1/2 lb.

**Worm and Rack Ball Preload**

Torque at Stub or Steering Shaft . . . . .	1 to 5 in. lbs. higher than thrust bearing preload
Lbs. Pull at Steering Wheel Rim . . . . .	1/8 to 5/8 lb. higher than thrust bearing preload

**Pitman Shaft "Over Center"**

Torque at Stub or Steering Shaft . . . . .	4 to 8 in. lbs. higher than worm and rack ball preload
Lbs. Pull at Steering Wheel Rim . . . . .	1/2 to 1 lbs. higher than worm and rack ball preload

**c. Pump Specifications**

Pump Capacity, gal./min. @ 480 RPM (Pump) x 550 psi . . . . .	1.25 Minimum
Relief Valve Opening Pressure, psi . . . . .	800 to 900
Pump Test Pressure, min. psi. @ 525 RPM (Engine) and 170°F. oil temperature . . . . .	750 Minimum
Drive Belt Adjustment, Torque on Pulley Nut to Slip Belt . . . . .	40-45 Ft. Lbs.

**d. Steering Linkage Specifications**

Same as Manual Steering . . . . . See Par. 8-1, Sub Par. C

## 8-9 DESCRIPTION OF ROTARY VALVE POWER STEERING GEAR AND PUMP

NOTE: The steering linkage for power steering is the same as used with manual steering except for the pitman arm which requires a larger splined hole for the power steering gear pitman shaft. See Figure 8-4.

The rotary valve power steering system is offered as optional equipment on the 4000 and 4100 series.

The rotary valve power steering gear gives precise, positive steering with very little driver effort. Initial hydraulic assist is obtained with approximately .3 degrees of steering wheel rotation and one pound of effort at the steering wheel rim. Full hydraulic assist is obtained with approximately 4 degrees of wheel rotation and 3 1/4 pounds of effort at the wheel rim.

The hydraulic pump is used to supply oil under pressure to operate the steering gear. The housing of the pump is enclosed in a reservoir which minimizes the possibilities of external leakage. A twist-off cap with a dip stick is used on the reservoir to simplify checking the oil level.

With the engine running, steering is manual under conditions which require an effort of less

than one pound at the steering wheel rim. When a greater effort is required, the power mechanism operates to assist in turning the front wheels. The effort then required at the steering wheel rim is limited to a maximum of approximately 3 1/4 pounds for normal steering and parking conditions.

When the engine is not running or if any part of the power mechanism is inoperative, the steering gear will operate manually giving the driver full control of the car.

The driver's effort on the steering wheel is always proportioned to the force necessary to turn the front wheels. When the effort on the wheel drops to less than one pound, power assistance ceases. When the steering wheel is released to recover from a turn, the front wheels return to the straight-ahead position in the normal manner without assistance or interference from the power mechanism. Through this conventional steering action the driver always has the "feel" of steering.

**a. Power Steering Gear Assembly**

The power steering gear assembly is the recirculating ball type, having a ratio of 17.5 to 1.

The upper end of the pitman shaft has a gear sector meshing with a rack-piston nut. The one-piece rack-piston nut serves as a nut for

the recirculating balls and as a power piston to which the oil under pressure is applied. The rack-piston nut has a Teflon piston ring with a back-up O-ring under it located on its lower outside diameter which serves as a seal between the rack-piston nut and its cylinder gear housing. See Figure 8-18.

A worm shaft turns in the rack-piston nut using the selectively fitted steel balls as a rolling thread. The ball groove is shallower in the center of the worm so that when the proper size balls are used, there is a slight worm to rack-piston nut preload in the straight-ahead position.

Worm shaft radial loads are transmitted to the gear housing through the rack-piston nut. Worm end thrust is caused by the tendency of the worm to thread itself into or out of the rack-piston nut as the steering wheel is turned right or left. This end thrust is absorbed entirely by the upper and lower thrust bearings. The upper thrust bearing is located between

the valve body and adjuster plug and the lower thrust bearing is located between the housing and upper end of worm.

The upper steering shaft is a separate shaft supported in the steering column jacket. Its upper end is supported by a ball bearing and its lower end by the stub shaft in the steering gear.

The steering shaft is connected to the power steering gear through a flexible coupling. This flexible coupling helps absorb minor shocks and vibrations, dampens out hydraulic noises and gear rattle and also allows slight variations in alignment between the gear assembly and the steering column jacket assembly.

The power steering gear identification number is stamped on the gear housing side cover. The first 3 digits show the day of the year (1 through 365) the gear was tested. The last digit shows the year (1 for 1961, etc.).

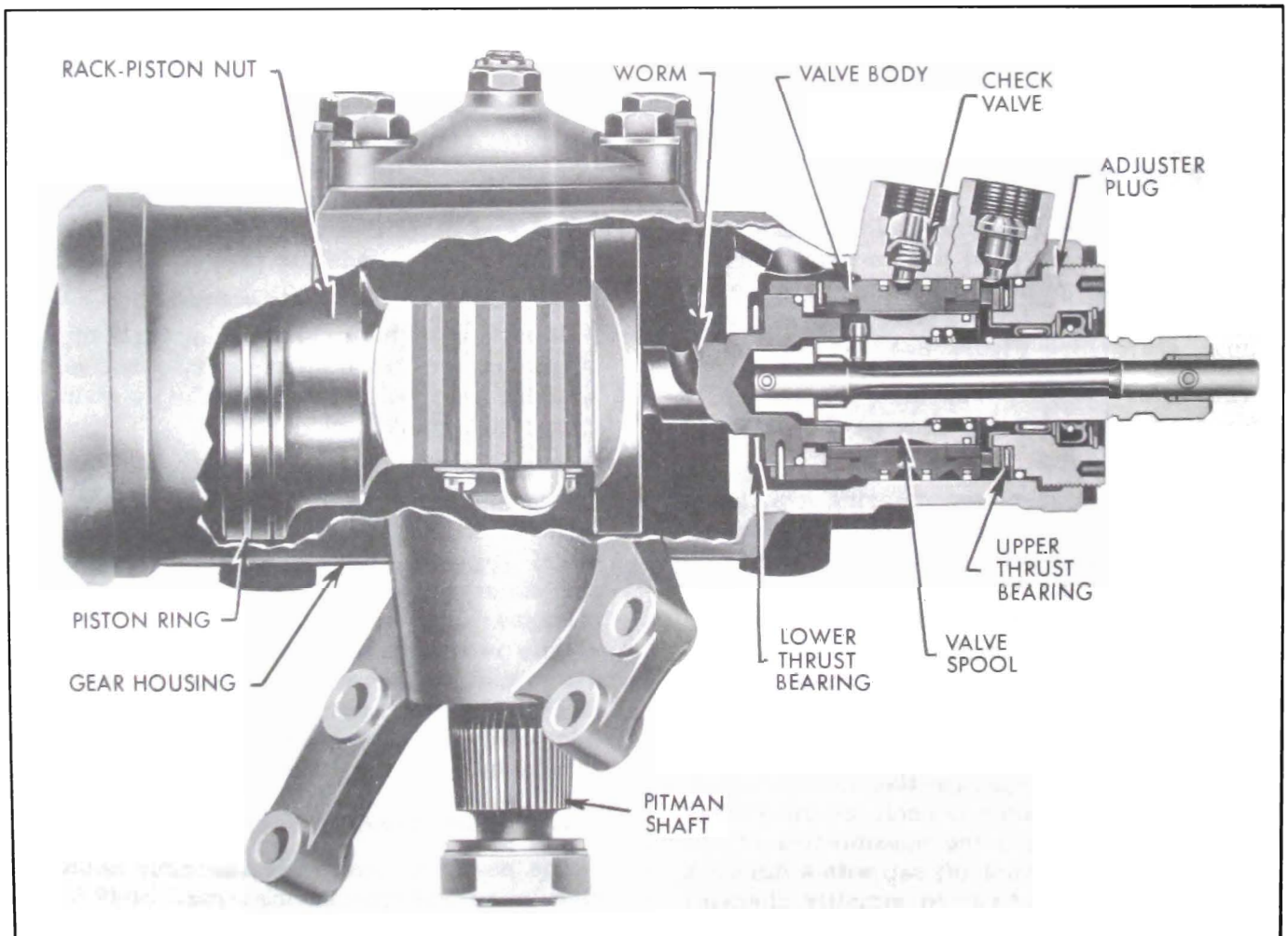

Figure 8-18—Power Steering Gear Assembly

### b. Rotary Valve Assembly

The rotary valve assembly controls the flow of oil from the pump to the proper side of the rack-piston nut when power assistance is required and cuts off this flow when power assistance is not required.

The rotary valve assembly is located in the upper section of the gear housing and consists of a stub shaft, a torsion bar, a valve body, a valve spool and a valve body cap. See Figure 8-19. The stub shaft is attached to the upper steering shaft through the flange assembly. The lower flange is splined to the stub shaft and is retained by a pinch bolt. The torsion bar is located in the center of the stub shaft. The valve spool is an open center valve and is positioned on the lower end of the stub shaft.

The valve body encloses the valve spool. The valve body cap is located at the lower end of the valve body.

The valve body has two large oil grooves around its outside diameter. Each groove has four holes drilled into the inside diameter of the valve body. The lower groove is lined up with the pressure port in the gear housing. The upper groove is lined up with a drilled passage in the housing which directs oil to the right turn chamber in the housing, located at the lower end of the rack-piston nut. Three valve body Teflon rings provide leakproof seals for the oil grooves on the valve body. The inside diameter of the valve body has eight slots machined in it, four are connected to the pressure groove by the four drilled holes. See Figure 8-20. The other four slots, which are wider, are connected to the return port in the housing through the valve spool. Near the center of the valve body are four other drilled holes which are used to direct oil to a passage in the housing that opens to the left turn chamber. This chamber is located at the upper end of the rack-piston nut.

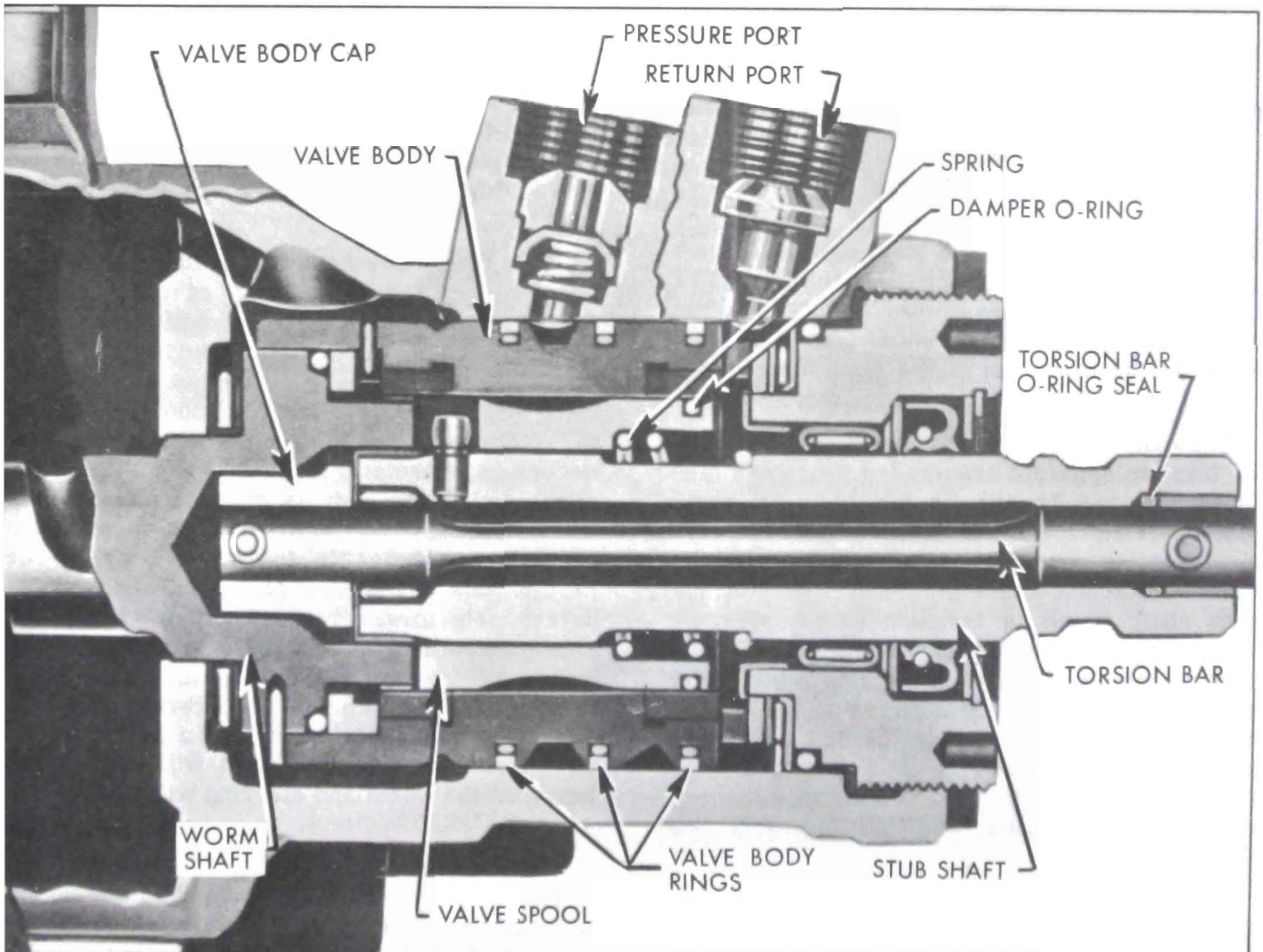

Figure 8-19—Rotary Valve Assembly



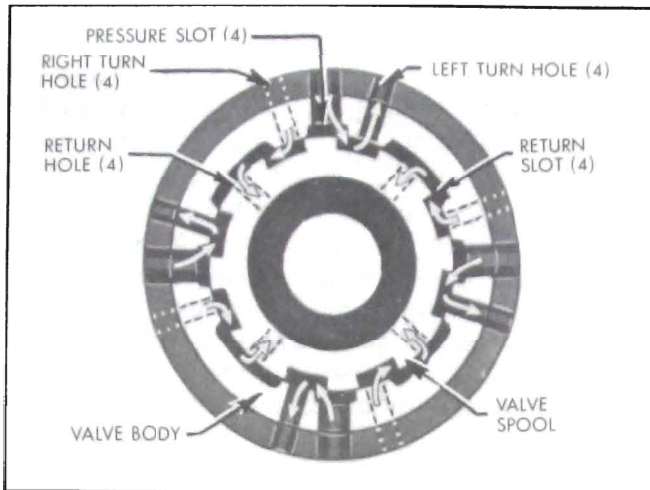

Figure 8-20—Upper End View of Rotary Valve - Left Turn

The valve spool which fits inside the valve body may have an outside diameter as low as only .0004 in. smaller than the inside diameter of the valve body. This close fit allows very little, if any, oil flow between the two surfaces. The valve spool has four holes drilled near the upper end of it which are in line with the four return slots in the valve body. These holes allow oil to flow from the return slots in the valve body to the center of the spool and on to the return port in the housing. The outside diameter of the spool has eight slots machined on it, four are for opening the right turn holes in the valve body to the pressure slots or to the return slots in the valve body. The other four slots on the spool serve the same function for the left turn holes in the valve body.

Basically the rotary valve assembly is divided into two separate assemblies which are fastened together by the torsion bar. To completely understand how the rotary valve functions, it must be known what parts are firmly attached together. Starting with the stub shaft which is fastened to the steering wheel through the upper steering shaft, the first assembly consists of the stub shaft, valve spool and upper end of the torsion bar. A pin on the outside diameter of the stub shaft retains the valve spool to it and a pin at the upper end of the stub shaft attaches the upper end of the torsion bar and shaft together. See Figure 8-21.

The other assembly which is connected to the front wheels of the car through linkage, pitman shaft and rack-piston nut, consists of the worm, valve body, valve body cap and lower end of the torsion bar.

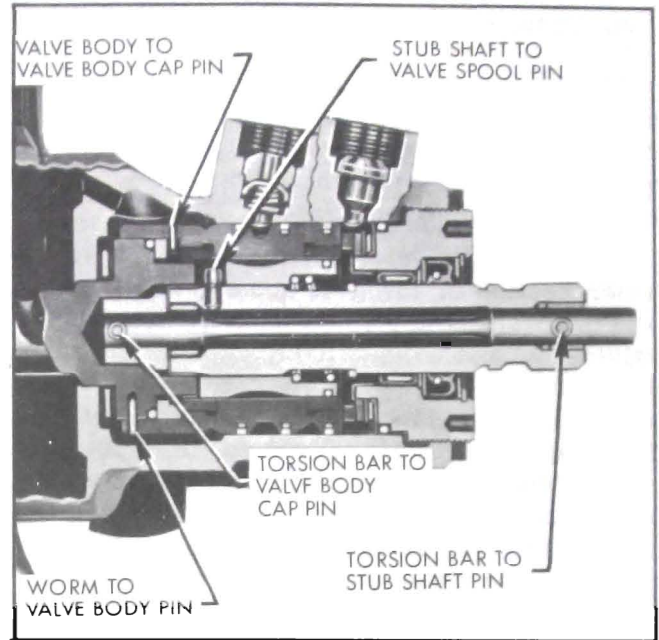

Figure 8-21—Attaching Pins for Valve Parts

The worm is attached to the valve body by a pin located at the upper end of the worm. A pin on the inside diameter of the valve body fastens the valve body cap to the valve body. To complete this assembly, a pin attaches the valve body cap to the lower end of the torsion bar.

When there is resistance to turning between the roadbed and the wheels of the car, the parts attached to the worm will also resist turning. Thus, when the steering wheel is turned by the driver, the torsion bar will deflect and allow the stub shaft and valve spool to rotate with the steering wheel. When this occurs, the relationship between the valve spool and valve body is changed and oil flow is directed by the slots on the valve spool through the holes in the valve body to the proper side of the rack-piston nut to assist the driver. The torsion bar deflection is limited to a predetermined amount. The upper end of the worm has two tangs which fit through slots in the valve body cap and into two slots in the end of the stub shaft. In case of a power mechanism failure, the stub shaft will contact the tangs of the worm and steering will be manual.

### c. Oil Pump and Hoses

The oil pump, which is mounted on the engine in position to be driven by a belt from the crankshaft balancer, converts some engine power into oil pressure which is used against the rack-piston nut to rotate the pitman shaft.

The pump reservoir encloses the pump housing and provides a reserve supply of oil to assure complete filling of the hydraulic system. See Figure 8-22. The reservoir cap is vented which permits escape of any air that may be introduced into the system during assembly of

the various units and maintains atmospheric pressure in the reservoir.

The pump housing encloses the flow control valve and the rotor assembly. The flow control valve and spring are retained in pump

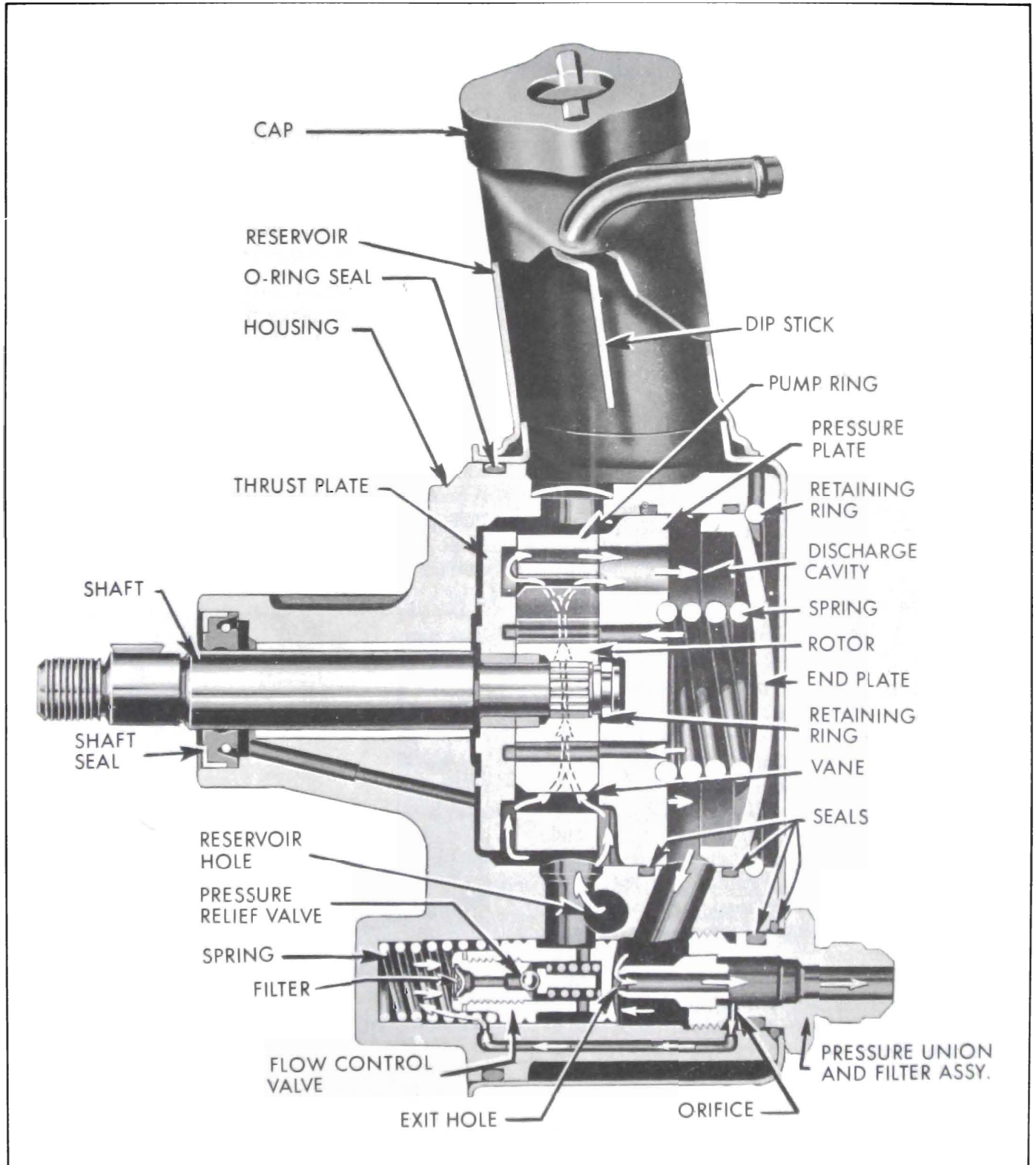

Figure 8-22—Oil Flow in Pump



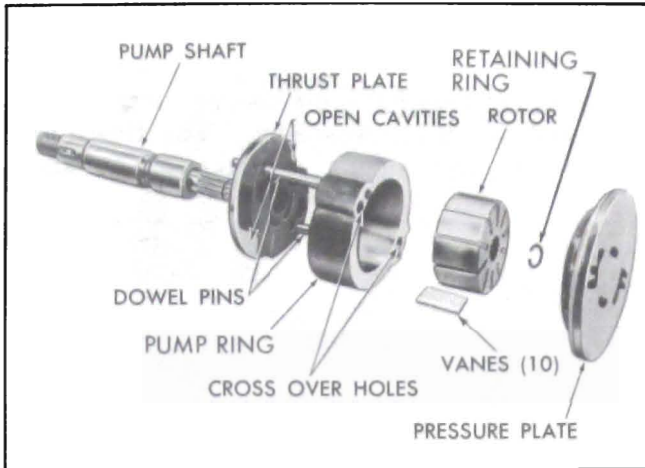

Figure 8-23—Rotor Assembly

housing by the pressure union. This allows servicing the flow control valve without removing pump from the engine. Inside the flow control valve is the pressure relief valve. The pressure union which is the pump outlet, contains the pump exit hole and a orifice. Also located in the flow control valve is a filter screen to filter the oil that enters the valve.

The rotor assembly consists of a drive shaft, a thrust plate, a rotor with ten vanes, a pump ring and a pressure plate. The shaft is retained to rotor by a retaining ring. Oil enters the rotor section of the housing through a reservoir hole in housing which is open to the surrounding reservoir.

The rotor is loosely splined to the end of the drive shaft, is located adjacent to the face of the thrust plate and is enclosed by the pump ring. The rotor vanes slide radially outward to contact the hardened and ground inside cam surface of the ring. See Figure 8-23. As the shaft and rotor rotate, centrifugal force and fluid pressure against the inner ends cause the vanes to follow the cam contour of the ring. The cam surface is so shaped that two opposite pumping chambers are formed which cause a complete pumping cycle to occur every 180 degrees of rotation of the rotor. The pump ring has two crossover passages drilled in it which transfer oil from the thrust plate into a discharge cavity located at the rear of the pressure plate.

When the engine is started, each pumping chamber picks up oil from two openings, one between the pressure plate and ring and the other between the thrust plate and ring. See Figure 8-22. The oil is then propelled by the

decreasing pockets in each pumping chamber into the discharge cavity through an opening in the pressure plate and an opening in the thrust plate which is connected to the cross-over passage in the ring. The oil flows from the discharge cavity into a passage which is open to the rear of the flow control valve and to the exit hole in one end of the pressure union. A certain quantity of oil flows through the outlet end of pressure union and on to the steering gear rotary valve assembly. Some oil flows through the orifice in the pressure union and into a passage in pump housing which directs oil into the spring chamber located in front of the flow control valve. Pressure in the discharge cavity is always greater than the pressure of the oil that has passed through the exit hole in the pressure union.

The flow control valve regulates the opening of a by-pass passage through which oil may be returned back to the suction and reservoir section of the pump.

When the pump is running without demand for steering pressure, pressure in the discharge cavity is great enough to push the flow control valve open against a spring load of approximately ten pounds. See Figure 8-24. The pressure in the spring chamber tends to close the valve but, since pressure in the discharge cavity is always greater than in the

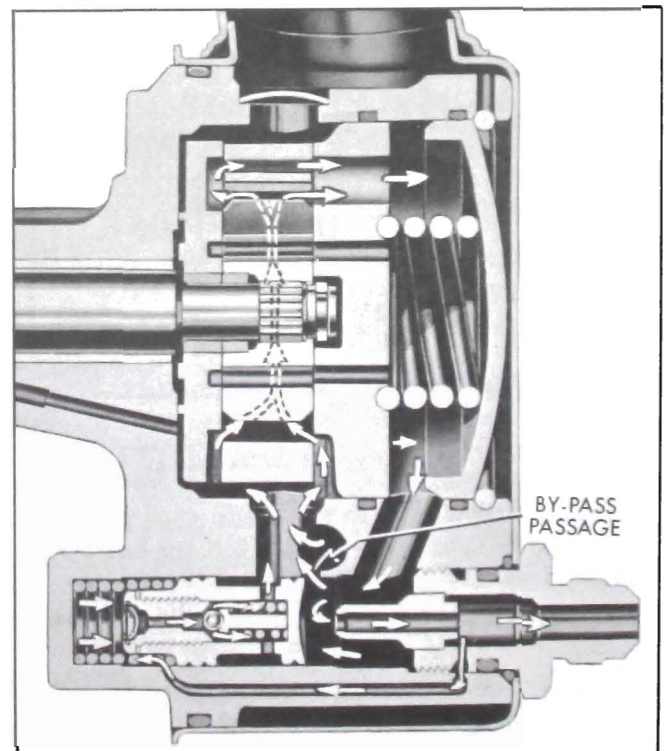

Figure 8-24—Flow Control Valve Operation

spring chamber, the valve is not closed. The movement of the valve is controlled by the spring tension and the difference in pressure on the front and rear side of the valve.

When power steering is demanded and the steering gear rotary valve restricts free circulation of oil as described later (par. 8-10), the pump pressure builds up rapidly. As the pressure increases in the discharge cavity it also increases in the spring chamber and in turn additional pressure is required to move the flow control valve to open the by-pass passage. The maximum amount of build-up of pressure by the pump depends on the amount of restriction through the gear which is controlled by the rotary valve. When power assistance is no longer required, the restriction through the gear is reduced to a predetermined minimum. With a small amount of restriction through the gear, the pressure in the spring chamber drops to a minimum value. Thus, the pressure in the discharge cavity also is reduced as this pressure is governed by the spring tension and the oil pressure present in the spring chamber of the pump.

If pump output pressure reaches 800 to 900 psi, the increased pressure in the spring chamber forces a pressure relief valve open and oil escapes from the spring chamber into the by-pass passage around the pressure relief valve ball. See Figure 8-24. As oil pressure is relieved in the spring chamber, the high pressure in the pump discharge cavity overcomes the spring load to open the flow control plunger. Because outlet pressure has to pass through an orifice to get into the spring chamber, the pressure in the spring chamber drops below outlet pressure for a fraction of a second. This allows the flow control plunger to be open enough to lower line pressure to a safe level immediately. Oil is then pumped into the by-pass passage until the line pressure opposing the pump drops below the relief valve setting, permitting this valve to close. The flow valve then resumes normal operation.

The flow control valve starts to open at 300-400 RPM of pump and is functioning when the pump is running 465 RPM (400 RPM of engine). The minimum flow a new pump must produce is 1.25 gal. per minute at 480 pump RPM against a pressure of 550 psi. The flow plunger permits a maximum flow of 1.75 gal. per minute at 1500 RPM against a pressure of 50 PSI. The pressure relief valve is set for 800 to 900 PSI.

The power steering pump identification number is stamped on the lower front surface of the housing. The first 3 digits show the day of the year (1 through 365) the pump was tested. Next is a letter for manufacturer identification (S for Saginaw). The last digit shows the year (1 for 1961, etc.).

A pressure hose connects the pressure union in the pump to the rotary valve in the steering gear housing and a return hose connects the rotary valve to the pump reservoir.

## **8-10 OPERATION OF ROTARY VALVE POWER STEERING GEAR**

### **a. Neutral or Straight-Ahead**

Figure 8-25 shows the rotary valve in the neutral or straight-ahead position. Oil flows from the pump into the pressure port of the gear, through the open center valve spool and back to the pump reservoir through the return port. The slots on the valve spool are so positioned in the valve body that the oil entering through the pressure port is directed to the return slots in the valve body, then through the center of the spool which is open to the return port. There is no flow to either side of the rack-piston nut, but each side is full of oil at all times. In the straight-ahead position the pressure on both sides is equal. The oil acts as a cushion that absorbs road shocks so they are not transferred to the steering wheel, thus giving safer and more effortless driving. In addition, this oil lubricates all the internal components of the gear.

All passages in the gear are open in the straight-ahead position and the valve remains in this position at all times except when effort applied to the steering wheel is more than one pound. The rotary valve's open center position design reduces pump losses to a minimum by allowing a minimum of restriction to oil flow in the straight-ahead position.

### **b. Right Turn**

Figure 8-26 illustrates the operation of the gear when the steering wheel is turned to the right. Due to the resistance to turning between the front wheels and the roadbed, the torsion bar is deflected, changing the relationship between the slots in the valve spool and the slots in the valve body. The right turn slots on the valve spool are closed off from the return slots



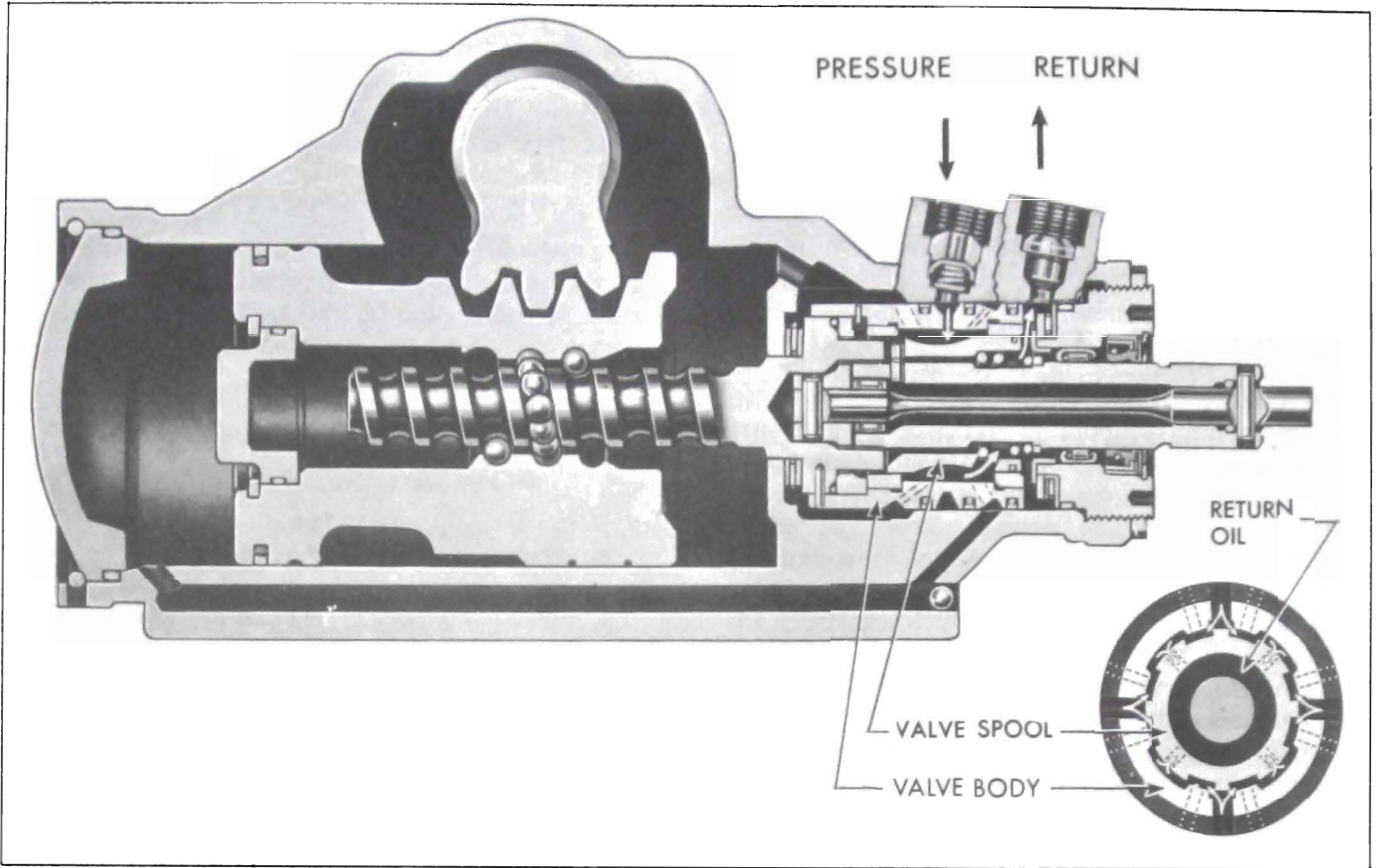

Figure 8-25—Oil Flow—Straight-Ahead

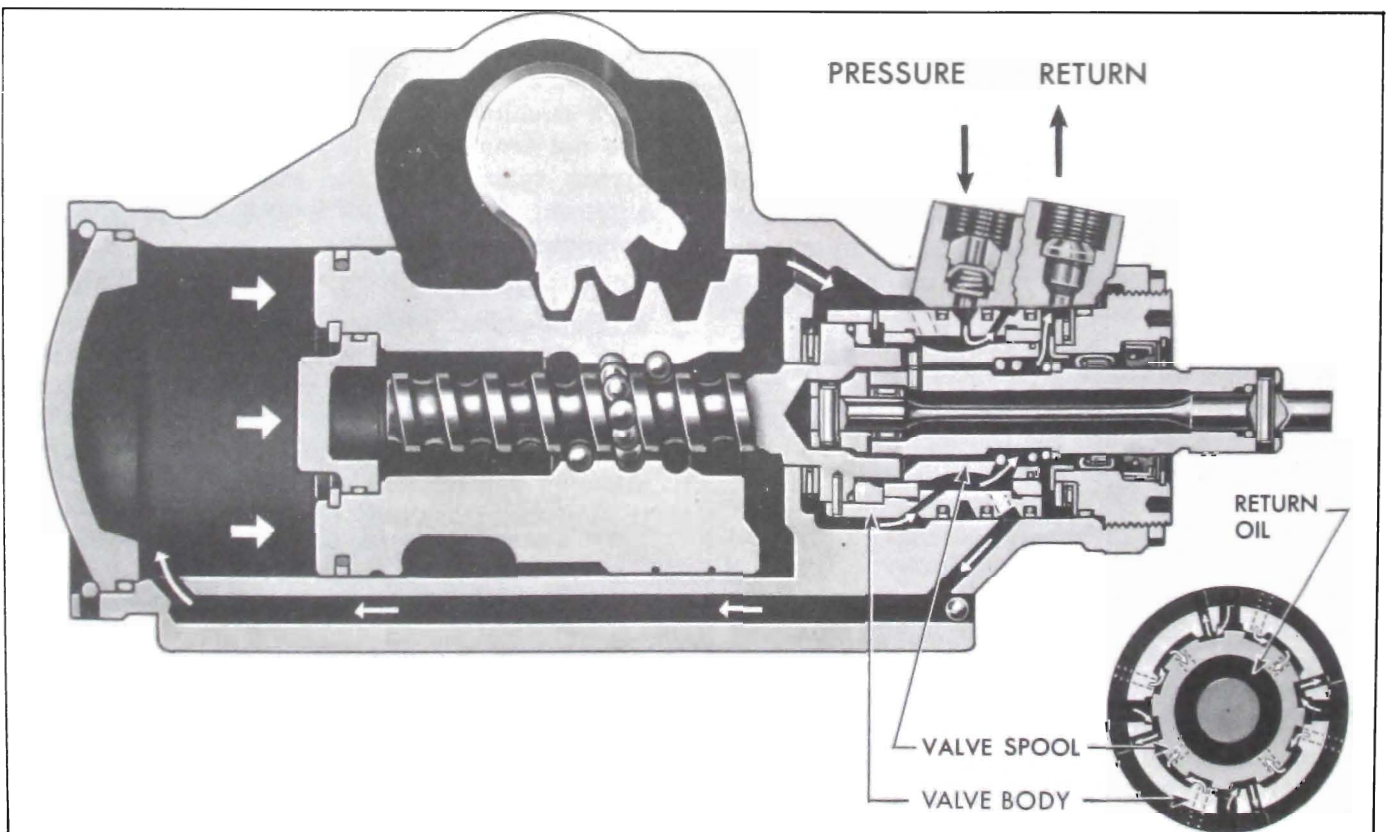

Figure 8-26—Oil Flow—Right Turn

in the valve body and are opened more to the pressure slots. The left turn slots of the spool are closed off from the pressure slots and opened more to the return slots. This causes oil to flow into the right turn chamber of the housing and force the rack-piston nut upward. As the rack-piston nut moves upward, it applies turning effort to the Pitman shaft.

The oil in the left turn chamber in the housing is simultaneously forced out through the valve and back to the pump reservoir. The higher the resistance to turning between the roadbed and the car wheels, the more the position of the valve spool is changed in relationship to the valve body and the higher the oil pressure on the lower end of the rack-piston nut. Since the amount of hydraulic pressure directed to the right turn chamber is dependent upon the resistance to turning, the driver is assured of the proper amount of smooth hydraulic assistance at all times.

The instant the driver stops applying steering effort to the steering wheel, the valve spool is moved back into its straight-ahead position in the valve body by the torsion bar. When this happens, the oil pressure is again equal on

both sides of the rack-piston nut and the steering geometry of the car causes the wheels to return to the straight-ahead position.

### c. Left Turn

Figure 8-27 illustrates the operation of the gear when the steering wheel is turned to the left. The resistance to turning of the front wheels causes the torsion bar to deflect, changing the relationship between the valve spool slots and the valve body slots. The slots are reversed from the right turn position and change the flow of oil into the left turn chamber in the housing, moving the rack-piston nut downward. Thus, turning effort is applied to the pitman shaft. The oil in the right turn chamber is forced through the valve back to the reservoir. When the driver stops applying steering effort, the valve spool returns to its straight-ahead position.

### d. Check Valve Poppet

The check valve is located in the pressure port of the housing under the connector. The valve consists of a poppet and a spring and its

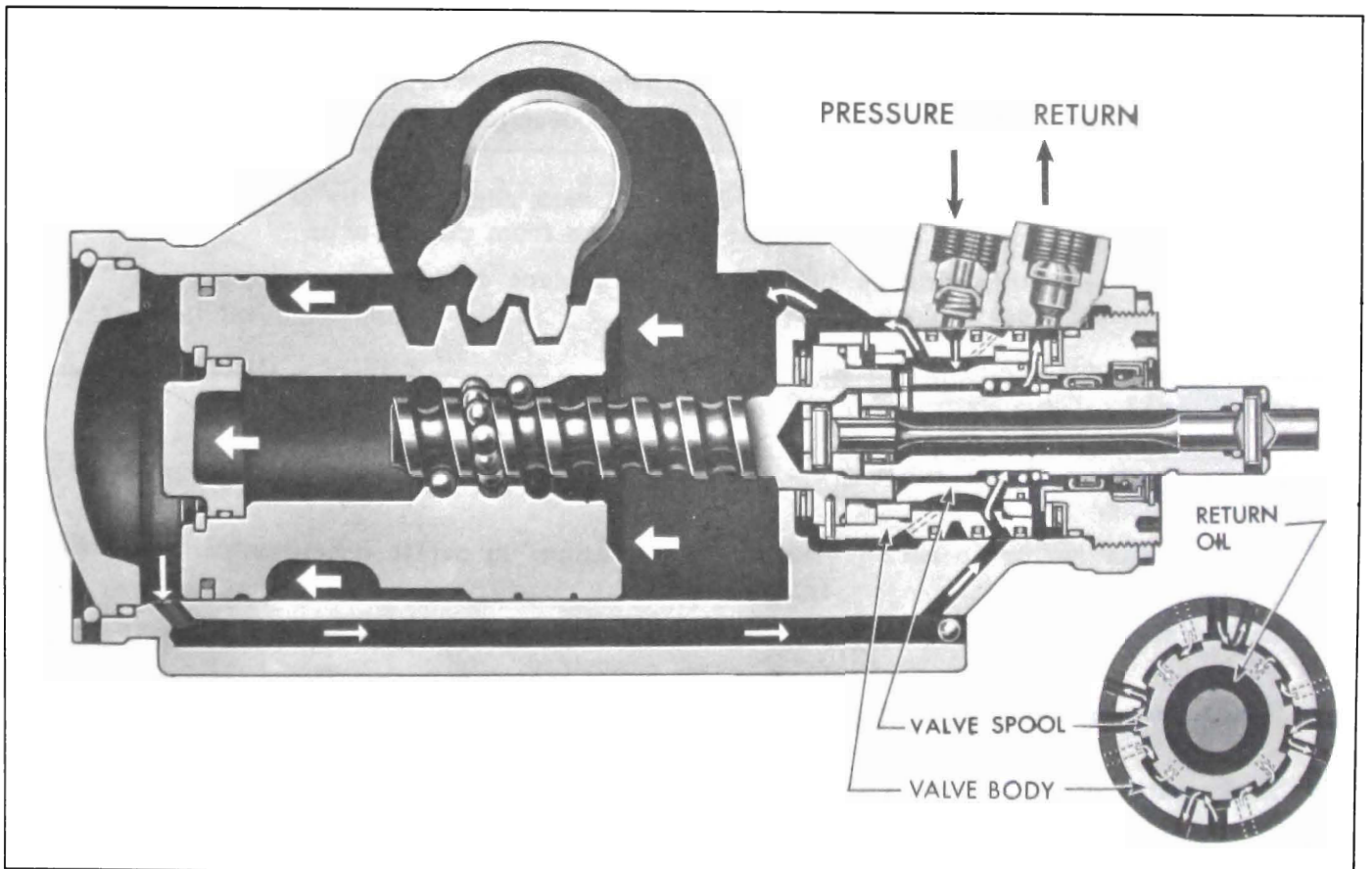

Figure 8-27—Oil Flow—Left Turn

purpose is to reduce the possibility of steering wheel "kick-back". If when making a turn, the front tire hits a bump which forces it in a direction opposite the turn, the impact will be carried up to the rack-piston nut by the pitman shaft. If the force is great enough, the rack-piston nut will tend to move against the applied oil pressure and force oil back through the valve assembly and out through the pressure port where the poppet valve is now located. If the rack-piston moved in the opposite direction, the steering wheel would resist momentarily or would "kick-back". The poppet valve is designed to prevent the above action from occurring by trapping the oil inside the gear.

#### **e. Steering Effort**

During normal driving, the steering wheel

effort will range from 1 to 2 1/4 pounds. The parking effort ranges from 2 to 3 1/4 pounds, depending upon the road conditions. Full hydraulic assist is obtained with approximately 3 1/4 pounds of effort at steering wheel rim. The more the turning resistance, the greater the pressure in the right or left turn chamber and the more effort the driver must apply to the steering wheel to turn the car. This proportional effort gives the driver the "feel of the road" at all times.

During normal driving conditions, the hydraulic oil pressure in the turn chambers should not exceed 125 psi. Pressure for cornering should not exceed 350 psi and parking pressure may range up to 800-900 psi depending upon the road surface.

### **8-11 TROUBLE DIAGNOSIS—POWER STEERING GEAR AND PUMP**

**NOTE:** This paragraph covers only those causes of trouble which may be due to the hydraulic power mechanism. Causes which are due to the steering linkage and front suspension are the same as described for standard steering gear in Paragraph 8-3.

COMPLAINT AND CAUSE	CORRECTION
<b>a. HARD STEERING WHILE DRIVING</b>	
<ol style="list-style-type: none"> <li>1. Lower coupling flange rubbing against adjuster plug.</li> <li>2. Steering adjustment tight.</li> <li>3. Insufficient pressure build-up in gear power cylinder due to leak or faulty valve.</li> </ol>	<ol style="list-style-type: none"> <li>1. Loosen pinch bolt and assemble properly.</li> <li>2. Check adjustment by disconnecting linkage from pitman arm.</li> <li>3. Replace defective parts.</li> </ol>
<b>b. POOR RETURN OF STEERING GEAR to CENTER</b>	
<ol style="list-style-type: none"> <li>1. Lower coupling flange rubbing against adjuster plug.</li> <li>2. Tight pitman sector to rack-piston nut adjustment.</li> <li>3. Rack-piston nut to worm preload too tight.</li> <li>4. Thrust bearing adjustment incorrect.</li> <li>5. Sticky valve spool.</li> <li>6. Steering shaft rubbing against transmission control shaft.</li> </ol>	<ol style="list-style-type: none"> <li>1. Loosen pinch bolt and assemble properly.</li> <li>2. Adjust in car to specification.</li> <li>3. Remove gear and replace balls as required.</li> <li>4. Remove gear and adjust to specification.</li> <li>5. Remove and clean valve. Replace rotary valve assembly if necessary.</li> <li>6. Align steering mast jacket assembly. See Figure 8-75.</li> </ol>



**8-11 TROUBLE DIAGNOSIS—POWER STEERING GEAR AND PUMP (Cont'd)**

COMPLAINT AND CAUSE	CORRECTION
<b>c. PUMP INOPERATIVE OR POOR OR NO ASSIST</b>	
NOTE: Refer to subpar. j, Step 4, to determine if pump is at fault.	
<ol style="list-style-type: none"> <li>1. Loose drive belt.</li> <li>2. Low oil level.</li> <li>3. Air in the oil.</li> <li>4. Defective hoses.</li> <li>5. Flow control valve stuck open.</li> <li>6. Loose screw in end of flow control valve.</li> <li>7. Pressure plate not flat against ring.</li> <li>8. Extreme wear of pump ring.</li> <li>9. Scored pressure plate, thrust and/or rotor.</li> <li>10. Vanes not installed properly.</li> <li>11. Vanes sticking in rotor slots.</li> <li>12. Faulty flow control valve assembly.</li> <li>13. O-ring improperly installed on pressure union.</li> <li>14. End plate improperly installed or seal damaged.</li> </ol>	<ol style="list-style-type: none"> <li>1. Tighten belt.</li> <li>2. Fill reservoir.</li> <li>3. Locate source of air leak and correct.</li> <li>4. Replace hose.</li> <li>5. Remove burrs or dirt.</li> <li>6. Tighten.</li> <li>7. Properly seat pressure plate against ring.</li> <li>8. Replace part.</li> <li>9. Lap away light scoring. Replace heavily scored parts.</li> <li>10. Install properly.</li> <li>11. Free up by removing burrs or dirt.</li> <li>12. Replace assembly.</li> <li>13. O-ring must be in groove nearest outlet of union.</li> <li>14. Install properly. Replace seal.</li> </ol>
<b>d. MOMENTARY INCREASE IN EFFORT WHEN TURNING WHEEL FAST TO THE RIGHT OR TO THE LEFT</b>	
<ol style="list-style-type: none"> <li>1. Air in system.</li> <li>2. Low oil level in pump.</li> <li>3. High internal leakage.</li> </ol>	<ol style="list-style-type: none"> <li>1. Bleed gear.</li> <li>2. Check oil level in pump reservoir.</li> <li>3. Replace rack-piston ring and back-up O-ring, rack-piston nut end plug seal, and/or replace valve.</li> </ol>
<b>e. External Oil Leaks</b>	
NOTE: Wipe gear and pump thoroughly and make sure source of leakage is determined.	
<ol style="list-style-type: none"> <li>1. Gear leaks. <ol style="list-style-type: none"> <li>(a) Loose hose connections.</li> <li>(b) Damaged hose.</li> <li>(c) Side cover O-ring seal.</li> <li>(d) Pitman shaft seal.</li> <li>(e) Housing end plug O-ring seal.</li> <li>(f) Adjuster plug O-ring seal.</li> <li>(g) Torsion bar O-ring seal.</li> <li>(h) Pitman shaft lash adjuster nut.</li> <li>(i) Stub shaft seal.</li> </ol> </li> </ol>	<ol style="list-style-type: none"> <li>(a) Tighten.</li> <li>(b) Replace.</li> <li>(c) Replace seal.</li> <li>(d) Replace seals.</li> <li>(e) Replace seal.</li> <li>(f) Replace seal.</li> <li>(g) Replace valve.</li> <li>(h) Replace nut.</li> <li>(i) Replace seal.</li> </ol>

## 8-11 TROUBLE DIAGNOSIS—POWER STEERING GEAR AND PUMP (Cont'd)

COMPLAINT AND CAUSE	CORRECTION
e. External Oil Leaks (Cont'd.)	
2. Pump leaks.	
(a) Oil leaking at top of reservoir as it is too full.	(a) Remove oil to proper level.
(b) Oil leaking at top of reservoir caused by air bubbles in oil.	(b) Locate source of air leak and correct.
(c) Reservoir O-ring seal damaged or improperly installed.	(c) Replace O-ring.
(d) Pressure union or reservoir to housing bolt and stud not tightened sufficiently.	(d) Torque union to 20 foot pounds and stud and bolt to 30 foot pounds.
(e) Pressure union or reservoir to housing bolt and stud cross threaded or damaged.	(e) Replace damaged parts.
(f) Defective pressure fitting seat on hose end.	(f) Replace hose.
(g) Damaged reservoir to housing or pressure union O-ring seals.	(g) Replace seals.
(h) Defective shaft seal.	(h) Replace seal.
(i) Damaged shaft at seal area.	(i) Replace shaft.
(j) Leaks in metal parts. (Example: Drawing crack in reservoir.)	(j) Replace defective part.
f. NOISE	
1. Gear Noise (rattle or chuckle).	
(a) Loose "overcenter" adjustment.	(a) Adjust to specification.
NOTE: A slight rattle may occur on turns because of the increased lash off the "high point". This is normal and the lash must not be reduced below the specified limits to eliminate this slight rattle.	
(b) Gear loose on cross member.	(b) Tighten mounting bolts to 55 foot pounds.
2. Gear Noise ("hissing" sound).	
(a) A hissing noise is natural when steering wheel is at end of travel or when slowly turning at stand still.	(a) Do not replace valve unless "hiss" is extremely objectionable. Investigate clearance around safety drive rivet pins. Be sure there is no metal-to-metal contact around flexible coupling as this will transmit valve hiss to car.
3. Gear Noise (squawk when turning or when recovering from a turn).	
(a) Cut or worn dampener O-ring on valve spool.	(a) Replace dampener O-ring.

**8-11 TROUBLE DIAGNOSIS—POWER STEERING GEAR AND PUMP (Cont'd)**

COMPLAINT AND CAUSE	CORRECTION
<p><b>f. NOISE (Cont'd)</b></p> <p><b>4. Pump Noise.</b></p> <p>(a) Loose belt.            (b) Hoses touching other parts of car.            (c) Low oil level.            (d) Air in the oil.            (e) Excessive back pressure caused by hoses or steering gear.</p> <p>(f) Scored pressure plate.</p> <p>(g) Vanes not installed properly.            (h) Vanes sticking in rotor slots.            (i) Extreme wear of pump ring.            (j) Face of thrust plate scored.</p> <p>(k) Scored rotor.</p> <p>(l) Defective flow control valve.</p>	<p>(a) Tighten belt.            (b) Adjust hose positions.            (c) Fill reservoir.            (d) Locate source of air leak and correct.            (e) Locate restriction and correct. With pressure gauge installed in pressure hose between pump and gear and engine running at 1500 RPM, oil warm, and no effort on the steering wheel, pressure should not exceed 125 psi. See Figure 8-28.            (f) Lap away light scoring. Replace heavily scored part.            (g) Install properly.            (h) Free up by removing burrs or dirt.            (i) Replace part.            (j) Lap away light scoring. Replace heavily scored part.            (k) Lap away light scoring. Replace heavily scored part.            (l) Replace.</p>
<p><b>g. EXCESSIVE WHEEL KICKBACK OR LOOSE STEERING</b></p> <p>1. Air in system.            2. Excessive lash between pitman shaft sector and rack-piston.            3. Loose thrust bearing adjustment.            4. Rack-piston nut to worm preload too low.            5. Incorrect installation or operation of the gear check valve poppet.</p>	<p>1. Add oil to pump reservoir and bleed.            2. Adjust to specification.            3. Remove gear and adjust to specification.            4. Remove rack-piston nut and worm, and change balls to obtain specified preload.            5. Check operation of valve, par. 8-16, subpar. c, Step 6.</p>
<p><b>h. STEERING WHEEL SURGES OR JERKS WHEN TURNING WITH ENGINE RUNNING</b></p> <p>Loose pump belt.</p>	<p>Adjust to specification.</p>
<p><b>i. HARD STEERING WHEN PARKING</b></p> <p>1. Loose pump belt.            2. Low oil level in reservoir.            3. Steering gear adjustments tight.</p>	<p>1. Adjust to specification.            2. Fill to proper level. If excessively low, check all lines and joints for evidence of external leakage.            3. Adjust to specification.</p>



## 8-11 TROUBLE DIAGNOSIS—POWER STEERING GEAR AND PUMP (Cont'd)

## COMPLAINT AND CAUSE

## CORRECTION

## i. HARD STEERING WHEN PARKING (Cont'd)

## 4. Insufficient oil pressure.

4. If all of the above checks do not reveal the cause of hard steering, make the following tests of oil pressure:

(a) Disconnect the pressure line at oil pump. Attach pressure gauge to pump. Connect the hose to end of gauge where the valve is located. See Figure 8-28.

(b) With engine at warm idle (525 RPM) and gauge valve open, note the oil pressure on the gauge while turning steering wheel from one extreme position to the other. Especially note the maximum pressure which can be built up with the wheel held in either right or left extreme position.

**CAUTION:** Do not hold wheel in extreme position for an extended period of time because it will drastically increase the oil temperature and will cause undue wear on the oil pump.

(c) With oil temperature between 150°F and 170°F, as measured with a thermometer in the reservoir, the maximum oil pressure should not be less than 750 psi for satisfactory power steering operation.

(d) If the maximum oil pressure is less than 750 psi, it indicates trouble in the pump, oil hoses, steering gear, or a combination of these parts. To eliminate the hoses and gear, close the gauge valve and quickly test pressure of the pump only with the engine at warm idle, then open the valve to avoid increasing oil temperature. A minimum pressure of 750 psi should be present with valve closed.

(e) Comparing the maximum pressure obtained in these two tests will indicate source of trouble as follows: Step (b) pressure low and Step (d) pressure normal indicates faulty external oil lines or steering gear. Step (b) and Step (d) pressures equally low indicates faulty oil pump.

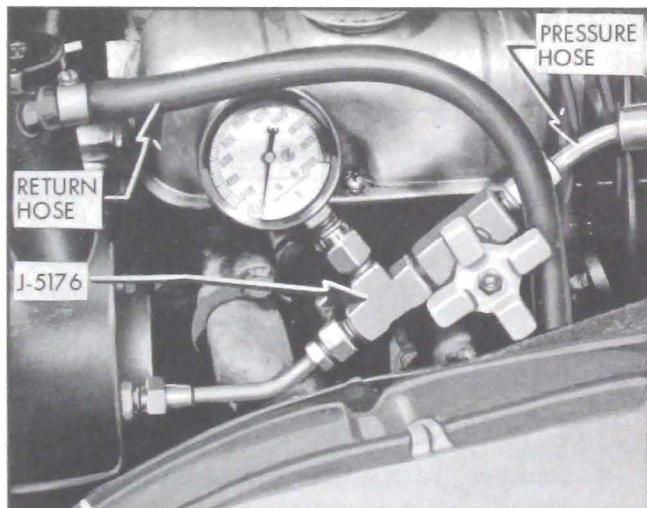

Figure 8-28—Pressure Gauge Installed

**8-11 TROUBLE DIAGNOSIS—POWER STEERING GEAR AND PUMP (Cont'd)**

COMPLAINT AND CAUSE	CORRECTION
<p>i. HARD STEERING WHEN PARKING (Cont'd)</p> <p>5. Low oil pressure in gear caused by restriction in hoses.</p> <p>(a) Check for kinks in hoses. (b) Foreign object stuck in hose.</p> <p>6. Low oil pressure due to steering gear.</p> <p>(a) Leakage at side cover O-ring, housing end plug O-ring, pitman shaft seals. (b) Pressure loss in cylinder due to worn piston ring, damaged back-up O-ring or scored housing bore. (c) Leakage at valve rings, valve body to worm seal, rack-piston end plug seal. (d) Loose fit of spool in valve body or leaky valve body. (e) Incorrect installation or operation of the gear check poppet valve.</p>	<p>(a) Remove kink. (b) Remove hoses and remove restricting object or replace hose.</p> <p>(a) Replace defective seals. (b) Remove gear from car for disassembly and inspection of rings and housing bore. (c) Remove gear from car for disassembly and replace seals. (d) Replace rotary valve assembly. (e) To determine if the poppet valve is installed and operating correctly, disconnect the pressure hose and install a pressure gauge between the hose and the pump. With the engine at warm idle (525 RPM) and no effort on the steering wheel, oil pressure should not exceed 60 psi with warm oil. If gauge indicates more than 60 psi the poppet valve should be checked for correct installation.</p>
<p>j. NO EFFORT REQUIRED TO TURN</p> <p>Broken torsion bar.</p>	<p>Replace rotary valve assembly.</p>

**8-12 REMOVAL AND INSTALLATION OF PITMAN SHAFT SEALS, STEERING GEAR AND OIL PUMP****a. Removal and Installation of Pitman Shaft Seals**

1. Remove steering gear as instructed in subparagraph b.
2. Thoroughly clean end of pitman shaft and gear housing.
3. Rotate the stub shaft until pitman shaft gear is in center position (2 1/8 turns from

either extreme position). Remove the housing side cover retaining bolts.

4. Tap the end of the pitman shaft with a soft mallet and slide shaft out of housing.

5. Remove the pitman shaft seal retaining ring from end of housing using No. 3 Truarc Pliers J-4245 and remove outer seal back-up washer. Tap a screw driver between the outer seal and the inner back-up washer and pry out seal. Tap the screw driver between the inner seal and the shoulder in the gear housing and pry out inner seal. Be careful not to damage the seal bore in housing. Discard seals.

6. Inspect housing for burrs and remove if necessary. Clean end of housing thoroughly to prevent entrance of dirt with installation of new seals.

7. Lubricate new pitman shaft seals in automatic transmission oil. Install the inner, single lip seal in bore first, then a back-up washer. See Figure 8-54. Using Tool J-6219, drive the seal and washer in far enough to provide clearance for the outer seal, back-up washer and retaining ring. See Figure 8-55. The inner seal must not bottom on the counter bore. Install the outer double lip seal and the second back-up washer in bore only far enough to provide clearance for the retaining ring with Tool J-6219. Install retaining ring with No. 3 Truarc Pliers Tool J-4245, making certain that ring is seated properly.

8. Wrap masking tape over the end of pitman shaft. Install the pitman shaft so that the center tooth in the sector meshes with the center groove of the rack-piston nut. Make sure the side cover O-ring seal is in place before pushing the side cover down on gear housing. Remove masking tape from end of shaft.

9. Install the four side cover bolts with lock-washers and tighten to 30 ft. lbs. Check pitman shaft "overcenter" adjustment. Correct if necessary.

10. Install gear assembly in car as instructed in subparagraph c.

### **b. Removal of Power Steering Gear**

NOTE: It is necessary to remove gear from car to remove pitman arm.

1. Disconnect return and pressure hoses from gear. Use shipping caps to cover ports in gear housing and open ends of hoses.

2. Remove two nuts and lock washers holding lower coupling to steering shaft flange.

3. Loosen clamp that retains mask jacket to toe pan cover and U-bolt that retains jacket to instrument panel. See Figures 8-73 and 8-74. Pull mast jacket up far enough to disengage steering shaft flange with flexible coupling.

4. Jack up car and disconnect pitman arm from intermediate rod by unscrewing end plug

until socket bearing will release pitman arm ball socket.

5. On Synchronesh transmission cars, remove lower coupling from gear stub shaft.

6. Remove the four steering gear to front suspension cross member bolts and nuts to remove gear assembly.

NOTE: Do not remove pitman arm from housing unless pitman shaft assembly, pitman shaft seals or rack piston nut are going to be removed.

7. Place pitman arm in vise and remove Pitman arm nut and lock washer.

8. Remove pitman arm from pitman shaft using Puller J-5504. See Figure 8-29.

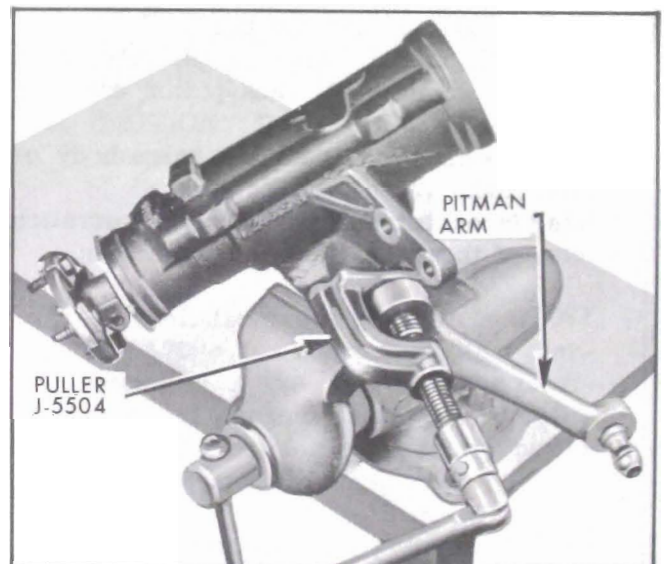

Figure 8-29—Removing Pitman Arm

### **c. Installation of Power Steering Gear**

1. Install pitman arm, lock washer and nut on pitman shaft. Place assembly in vise as shown and torque nut to 95 ft. lbs. See Figure 8-30.

2. Attach gear to cross member with the four bolts, nut and lock washers. Torque to 55 ft. lbs.

3. On Synchronesh cars install lower coupling on gear stub shaft. There must be at least 1/16" clearance between coupling and adjuster plug. See Figure 8-35.



4. Install pitman arm socket in intermediate rod being sure that socket bearings are properly seated around socket. Adjust end plug as shown in Figure 8-4 and install cotter pin.

5. Position mast jacket assembly so that flange on steering shaft is properly positioned on flexible coupling. Make sure coupling rivet heads are positioned in the center of their correct slots in flange. Small rivet goes in small slot and large rivet in large slot.

6. Tighten mast jacket clamp and U-bolt. Be sure that tang of mast jacket saddle engages slot in jacket and that steering shaft is centered in end of jacket assembly. See Figures 8-74 and 8-75.

7. Install two nuts and lock washers on the two bolts that retain lower coupling to steering shaft flange. Flange must not contact rivets and horn ground wire must be on bolt between coupling and flange.

8. Connect pressure and return hoses to gear.

9. Fill pump reservoir to correct level with automatic transmission oil.

10. Start engine and maintain oil level in reservoir while allowing engine to idle for at least three minutes before turning steering wheel. Then rotate steering wheel through its entire range slowly a few times with engine running. Recheck oil level and inspect for possible leaks.

NOTE: If air becomes trapped in the oil, the oil pump may be noisy until all air is out

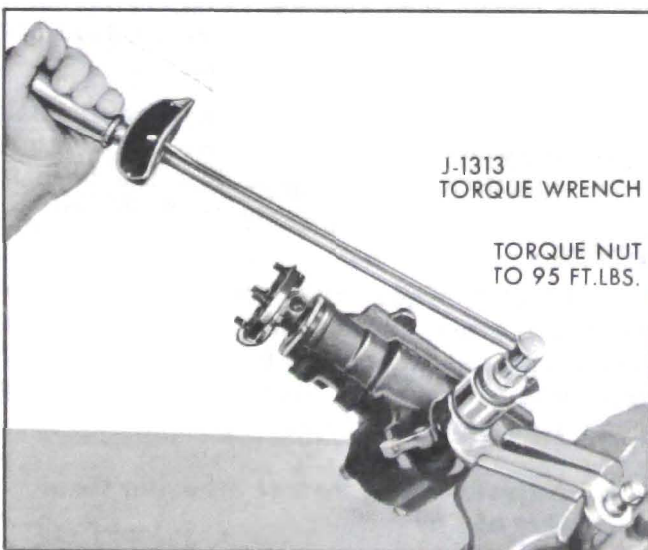

Figure 8-30—Torquing Pitman Arm Nut

of oil. This may take some time since air trapped in oil does not bleed out rapidly.

#### d. Removal of Oil Pump

It is not necessary to remove oil pump to service the flow control valve.

1. Remove pump pulley nut. Disconnect belt from pulley and remove pulley. Do not hammer pulley off shaft.

2. Place drain pan under pump and disconnect return and pressure hoses from pump. Use shipping caps to cover return pipe and union on pump and open ends of hoses.

3. Remove the two nuts that attach pump to front mounting bracket and the one nut that attaches it to rear bracket.

4. Loosen the three front bracket attaching bolts just enough so pump can be removed from brackets. Do not loosen front bracket attaching bolts any more than necessary as they enter the engine water jacket. If pump is not going to be reinstalled right away, retighten front bracket bolts to prevent possible leakage.

NOTE: On air conditioner cars do not loosen front bracket, but remove rear bracket with pump.

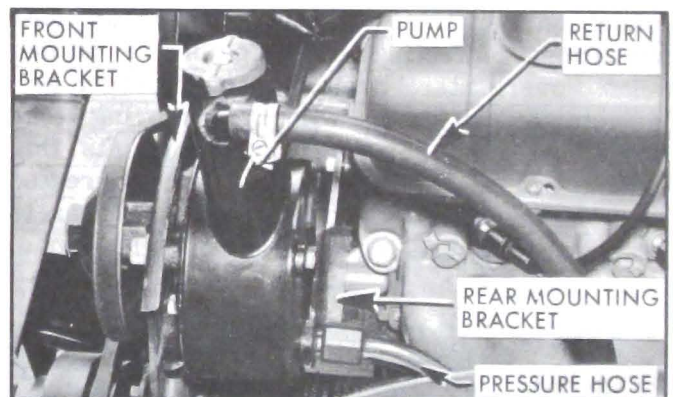

Figure 8-31—Oil Pump Mounting

#### e. Installation and Bleeding of Oil Pump

See paragraph 8-8 for tightening specifications.

1. Position pump in front and rear mounting brackets and tighten front bracket attaching bolts.

2. Attach pump to front and rear brackets.

3. Connect pressure and return hoses to pump.

4. Install pulley and nut with plain washer on pump shaft.

5. Place pump drive belt in pulley and adjust tension by using torque wrench applied to pulley nut. The tension should be set so pulley will slip in belt when 40 to 45 ft. lbs. torque is applied to pulley nut.

6. Fill pump reservoir to correct level with automatic transmission oil.

7. Start engine and maintain oil level in reservoir while allowing engine to idle for at least three minutes before turning steering wheel. Then rotate steering wheel through its entire range slowly a few times with engine running. Recheck oil level and inspect for possible leaks.

NOTE: If air becomes trapped in the oil, the oil pump may be noisy until all air is out of oil. This may take sometime since air trapped in oil does not bleed out rapidly.

### **8-13 ADJUSTMENT OF POWER STEERING GEAR AND LINKAGE**

#### **a. Adjustment of Power Steering Gear in Car**

IMPORTANT: Thrust bearing preload and worm to rack piston nut ball preload have little effect on handling. The most important gear adjustment affecting handling is the pitman shaft "overcenter" preload. The "overcenter" adjustment is made without removing gear from car, thus on handling complaints this adjustment should be checked and corrected and car road tested before removing gear to change thrust bearing preload or ball preload.

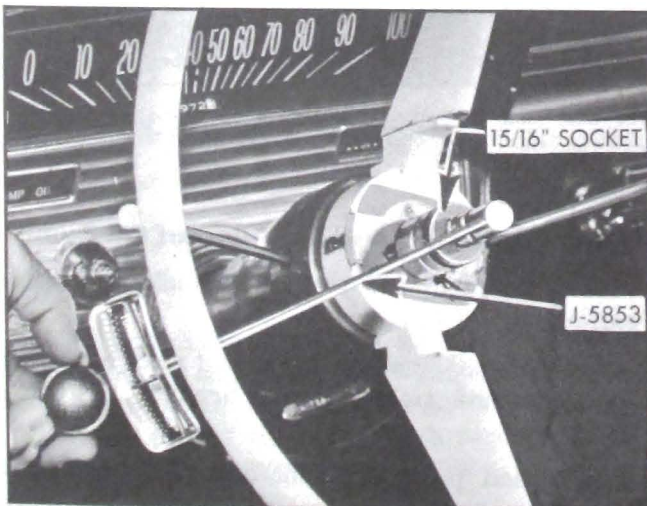

Figure 8-32—Checking Adjustments in Car

1. Disconnect pitman arm from intermediate rod.

NOTE: Never attempt to adjust steering gear with pitman arm connected to intermediate rod.

2. Remove horn emblem or cap from steering wheel hub.

3. Turn steering wheel slowly through its full travel to check for binding, tight spots or uneven action.

NOTE: If a spring scale is used to check adjustments, follow specifications listed in par. 8-8, b.

4. Turn steering wheel to extreme right or left position. Attach torque wrench J-5853 to steering wheel retaining nut and check the torque required to turn the wheel steadily in the range where lash normally exists between rack-piston nut and pitman shaft sector. See Figure 8-32. The lash range exists for one-eighth turn of steering wheel from either extreme position.

5. The reading on the torque wrench should be between 2 and 11 inch pounds, which would indicate normal preload at the thrust bearing and drag at the valve assembly.

6. Turn steering wheel 1/2 to 3/4 of a turn off "high-point" (center position) of gear. Worm to rack ball preload is checked with gear in this position.

NOTE: It is not necessary to back off pitman shaft lash adjuster to check ball preload when gear is positioned as instructed in Step 6.

7. Check the torque required to turn the wheel. The reading should be 1 to 5 inch pounds higher than reading recorded in Step 5 which would indicate normal ball preload between worm and rack-piston nut.

NOTE: The thrust bearing preload and ball preload readings should be close to the minimum specification on a gear that has been in use. On a new gear, these readings will be greater.

8. Check torque required to turn wheel through the gear "high-point" (center position). The reading should be 4 to 8 inch pounds higher than was obtained in Step 7. Adjust pitman shaft lash adjuster if necessary.

#### **b. Adjustment of Power Steering Gear Out of Car**

1. This adjustment is made when the gear is completely assembled and with gear on bench.



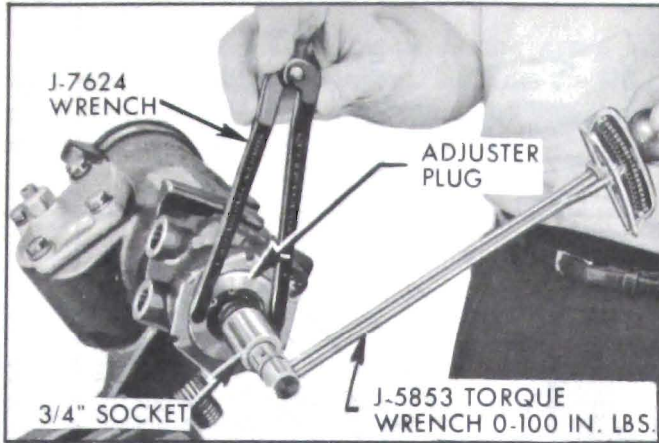

Figure 8-33—Adjusting Thrust Bearing Preload

2. Remove lower flange pinch bolt and remove flange from stub shaft.

3. Loosen adjuster plug lock nut and back off adjuster plug approximately 1/8 turn with adjustable spanner wrench J-7624. Attach torque wrench J-5853 with 3/4 inch 12 point socket to stub shaft and turn shaft to approximately 1/2 turn from either extreme. Slowly rotate wrench in an arc approximately 60° (1/6 turn) in both directions several times to measure valve drag and record highest reading. See Figure 8-33. Then tighten adjuster plug until thrust bearing preload is 1 to 3 inch pounds in excess of drag measured with adjuster plug backed out. Total of thrust bearing preload and valve drag should not exceed 11 inch pounds.

4. Turn stub shaft 1/2 to 3/4 of a turn off "high-point" (center position) of gear. Worm to rack ball preload is checked with gear in this position.

**NOTE:** It is not necessary to back off pitman shaft lash adjuster to check ball preload when gear is positioned as instructed in Step 4.

5. Check the pull required to turn stub shaft. The reading should be 1 to 5 inch pounds higher than total reading obtained in Step 3. If reading is not within specification it will be necessary to readjust ball preload between worm and rack-piston nut.

6. If readings are within specifications, check and adjust if necessary, pitman shaft "overcenter" adjustment. Reading on torque wrench should be 4 to 8 inch pounds higher than was obtained in Step 5. See Figure 8-34. This reading is taken when rotating stub shaft through "high-point" range with lash adjuster nut tight.

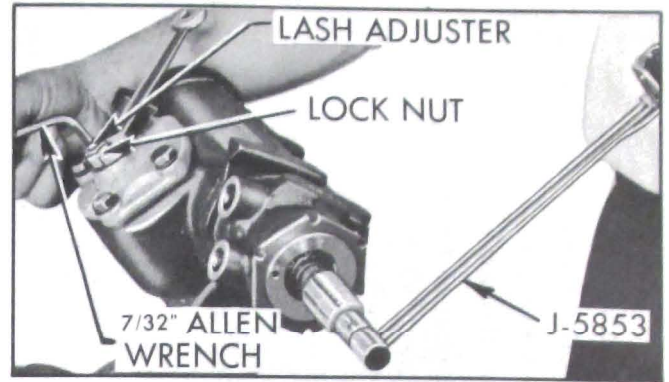

Figure 8-34—Pitman Shaft Over Center Adjustment

7. Align flat section in lower flange with flat on stub shaft and install flange. Center bolt hole on flange with groove on stub shaft. Install pinch bolt and tighten to 30 ft. lbs. There must be at least 1/16" clearance between coupling and adjuster plug. See Figure 8-35.

**NOTE:** Do not install coupling at this time if gear is to be installed in Synchronesh equipped car.

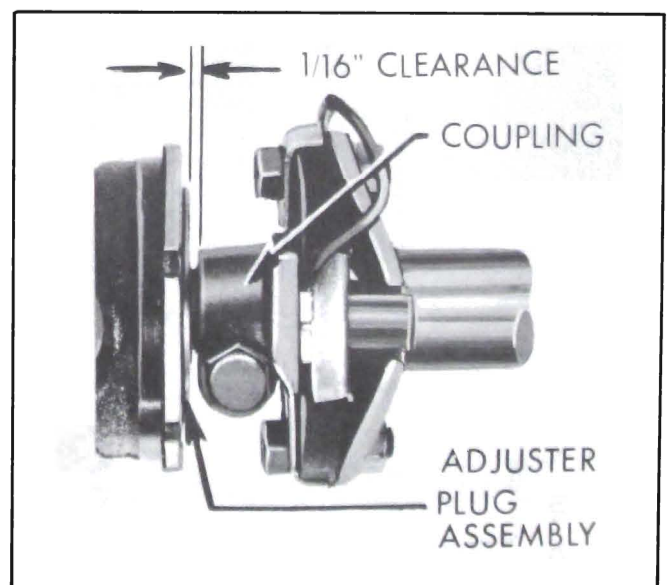

Figure 8-35—Correct Installation of Lower Coupling





### c. Adjustment of Power Steering Linkage

The power steering linkage is the same as used with manual steering except for the Pitman arm. Adjustment procedure is the same as listed in par. 8-4, subpar. c.

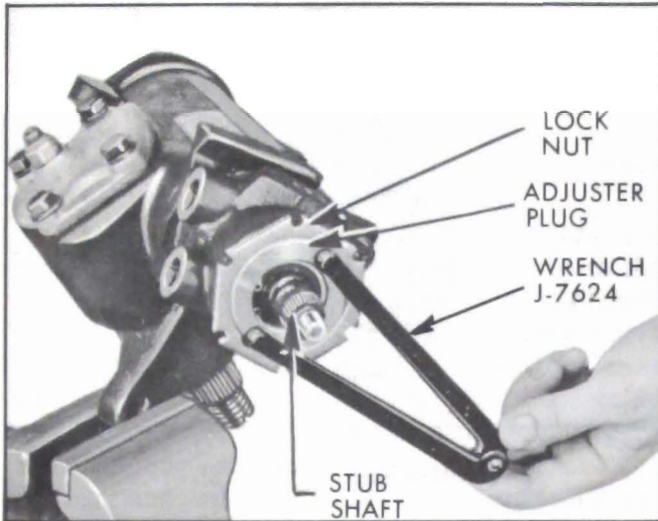

Figure 8-37—Removing Adjuster Plug Assembly

## 8-14 DISASSEMBLY, INSPECTION AND ASSEMBLY OF ADJUSTER PLUG ASSEMBLY AND ROTARY VALVE ASSEMBLY

### a. Removal of Adjuster Plug Assembly and Rotary Valve Assembly

1. Thoroughly clean exterior of gear assembly with a suitable solvent. Drain the unit by placing the valve ports down and turning the worm through its entire range two or three times.

2. Place gear assembly in vise.

3. Remove lower flange pinch bolt and remove flange from stub shaft.

4. Loosen adjuster plug lock nut and remove adjuster plug using adjustable spanner wrench, J-7624. See Figure 8-37.

**NOTE:** A punch may be used to loosen lock nut.

5. Remove rotary valve assembly from gear by grasping stub shaft and pulling out.

**NOTE:** If it is only necessary to service the rotary valve assembly, proceed with subpar. e below.

### b. Disassembly of Adjuster Plug Assembly

1. Remove the upper thrust bearing retainer

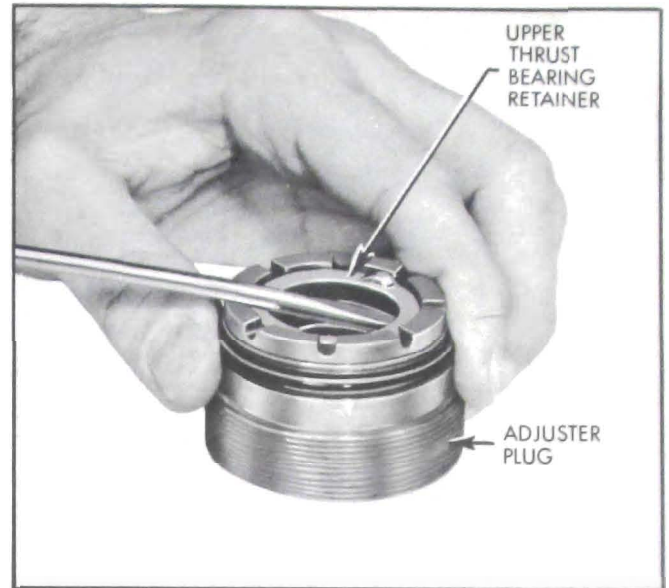

Figure 8-38—Removing Upper Thrust Bearing Retainer

with a screw driver, being careful not to damage the needle bearing bore. See Figure 8-38. Discard retainer. Remove thrust bearing spacer, upper thrust bearing and thrust bearing races.

2. Remove adjuster plug O-ring seal and discard.

3. Remove stub shaft seal retaining ring using No. 3 Truarc Pliers J-4245 and remove and discard dust seal. See Figure 8-39.

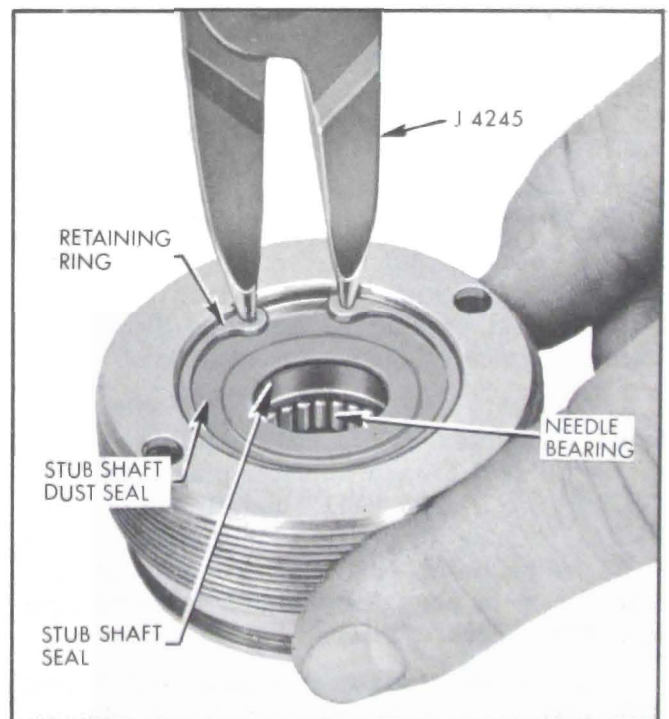

Figure 8-39—Removing Stub Shaft Seal Retaining Ring

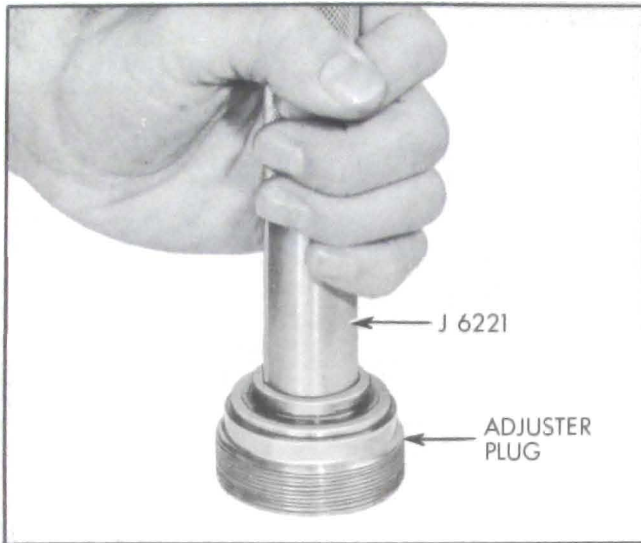

Figure 8-40—Removing Adjuster Plug Needle Bearing

4. Remove stub shaft seal by prying out with screw driver and discard.

5. Inspect needle bearing in adjuster plug and if rollers are broken or pitted, remove needle bearing by pressing from thrust bearing end using Tool J-6221 and discard bearing. See Figure 8-40.

#### c. Inspection of Adjuster Plug Assembly

1. Inspect thrust bearing spacer for cracks.
2. Inspect thrust bearing rollers and thrust bearing races for wear, pitting, scoring, cracking or brinelling. Replace any damaged parts.

#### d. Reassembly of Adjuster Plug Assembly

1. If needle bearing was removed because of damage, install new needle bearing from thrust bearing end of adjuster plug, by pressing against identification end of bearing using Tool J-6221. End of bearing must be flush with bottom surface of stub shaft seal bore.

2. Lubricate new stub shaft seal with automatic transmission oil and install seal with spring in seal toward adjuster plug using Tool J-5188. See Figure 8-41. Install seal only far enough in plug to provide clearance for dust seal and retaining ring. Place new dust seal with lip up in plug, then install retaining ring with No. 3 Truarc Pliers, J-4245.

3. Lubricate new adjuster plug O-ring seal with petroleum jelly and install on adjuster plug. Assemble large O.D. thrust bearing race (1 5/16" I.D. and 2" O.D.) with internal flange

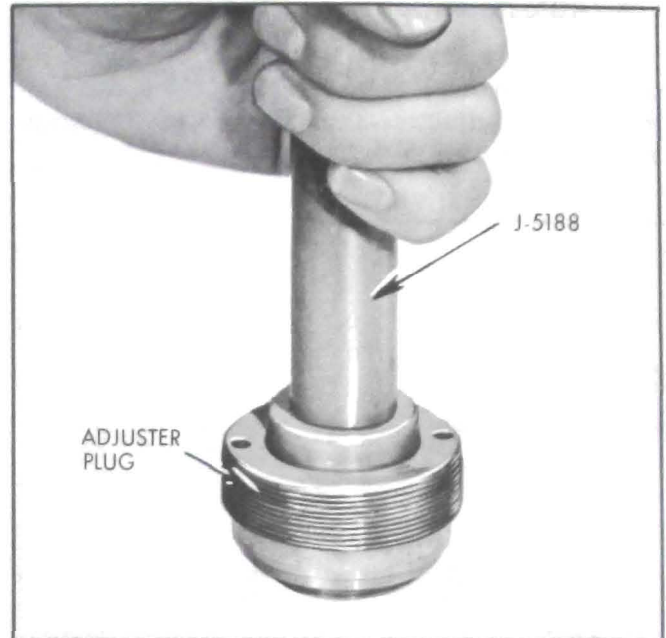

Figure 8-41—Installing Stub Shaft Seal

up on adjuster plug, then thrust bearing, thrust bearing race (1 3/8" I.D. x 1 15/16" O.D.) and thrust bearing spacer on adjuster plug. Install new thrust bearing retainer into needle bearing bore using punch, being careful not to damage spacer. See Figure 8-42. Radial location of dimples on retainer is not important. Thrust bearing assembly and spacer must be free to rotate and retainer must be completely below surface of spacer.

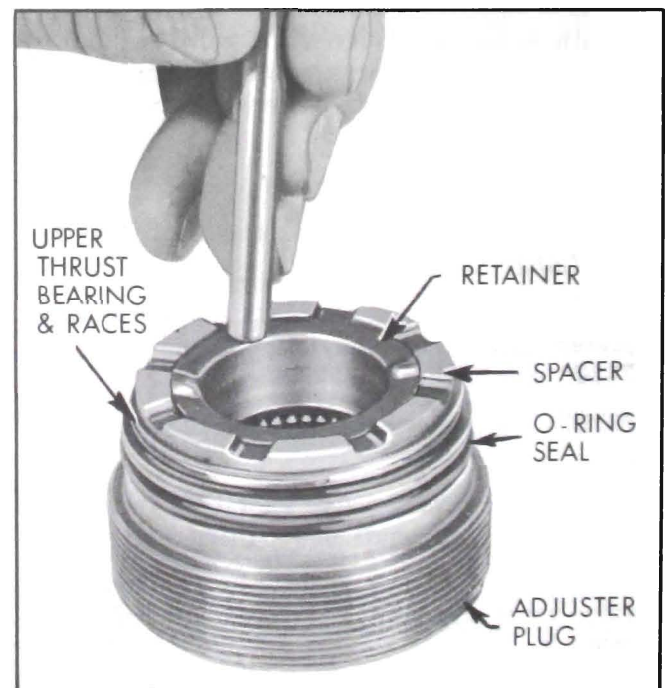

Figure 8-42—Installing Upper Thrust Bearing Retainer



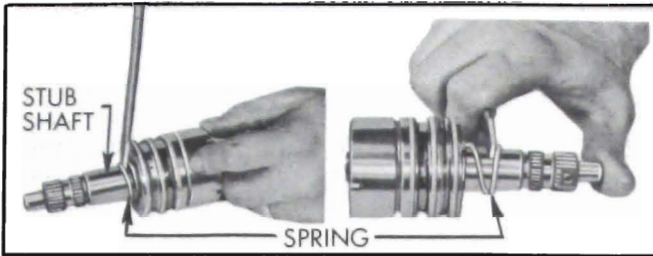

Figure 8-43—Removing Valve Spool Spring

### e. Disassembly of Rotary Valve Assembly

It is very uncommon to have to make any service repairs to the valve assembly with the possible exception of the valve spool dampener O-ring seal. DO NOT disassemble the valve unless absolutely necessary since this may result in damaging the assembly. If the valve spool dampener O-ring seal requires replacement, remove the valve spool only, replace the O-ring and reinstall the spool immediately. DO NOT disassemble further.

**CAUTION:** Cleanliness of parts, tools and work area is of the utmost importance during servicing of the valve assembly.

1. Remove cap to worm O-ring seal and discard.

2. Remove valve spool spring by prying on small coil with a small screw driver to work spring onto bearing surface of stub shaft. See Figure 8-43. Slide spring off shaft. Be very careful not to damage stub shaft surface.

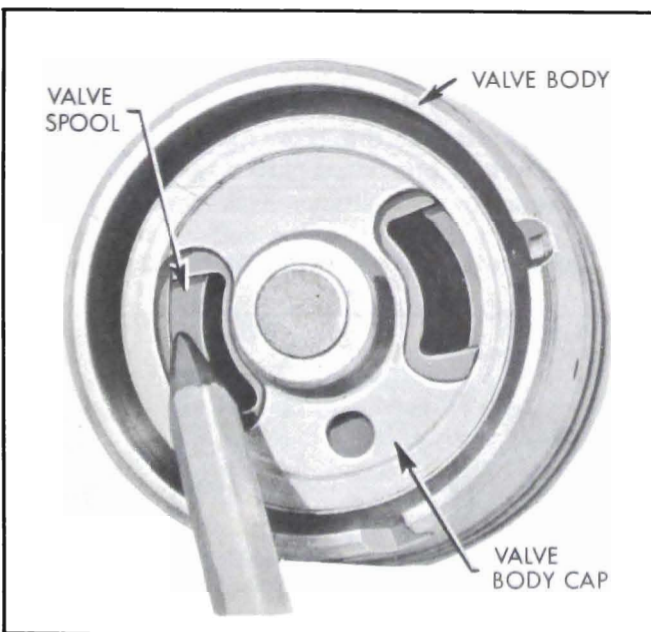

Figure 8-44—Separating Valve Spool From Valve Body

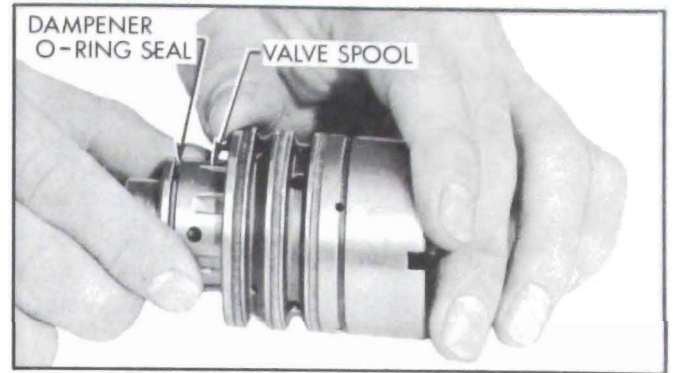

Figure 8-45—Withdrawing Valve Spool From Valve Body

3. Remove the valve spool by holding the valve assembly in one hand with the stub shaft pointing downward. Insert the end of a pencil or wood rod through the opening in the valve body cap and lightly push on the valve spool until it is far enough out of the valve body to be withdrawn. See Figure 8-44. Withdraw the spool with a steady rotating pull to prevent jamming. See Figure 8-45. If slight sticking occurs, make a gentle attempt to reverse the withdrawal procedure. If this does not free spool, it has become cocked in the valve body bore. Do not attempt to force the spool in or out if it becomes cocked, but continue with the following step.

**CAUTION:** The valve spool must be removed with extreme care. The clearance between the valve body and the spool may be as low as .0004 inch. The slightest cocking of the spool may jam it in the valve body.

4. Remove the stub shaft, torsion bar and cap assembly by holding the valve assembly with stub shaft downward as shown and rapping torsion bar lightly against work-bench to dislodge the cap from valve body to cap pin. See Figure 8-46. Complete the removal of the stub shaft torsion bar and cap assembly.

5. If the valve spool became cocked as described in Step 3 above, it can now be freed by visually determining in which direction it is cocked. Tap the spool lightly with a plastic or wood rod to align it and free it in the valve body bore. Do not tap spool with anything metallic.

6. Remove valve spool dampener O-ring seal and discard.

7. If there is evidence of wear or leakage, carefully cut and remove three valve body rings and three ring back-up O-ring seals. Discard rings and seals.

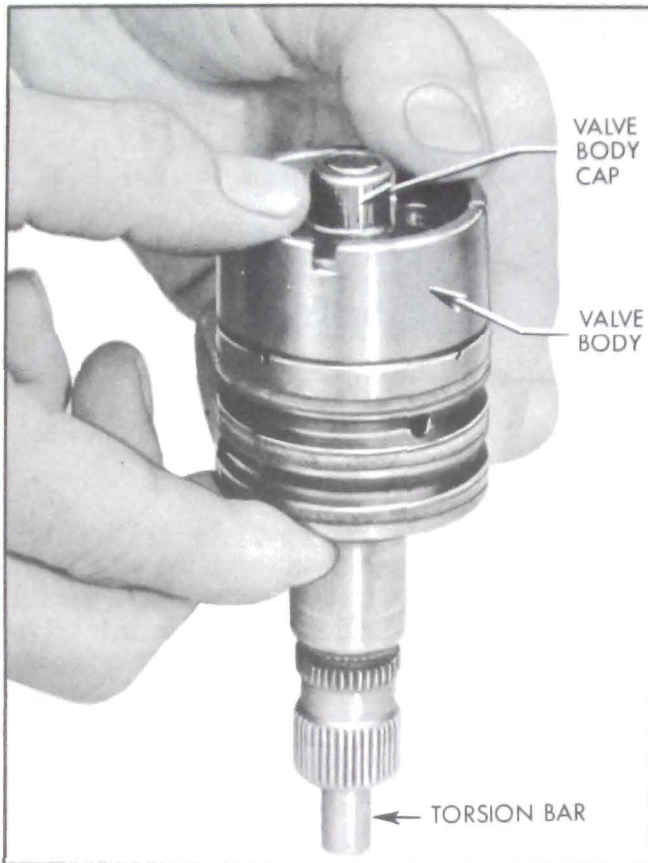

Figure 8-46—Disassembly of Valve Assembly

#### f. Inspection of Rotary Valve Assembly

The rotary valve assembly is a precision unit with selectively fitted parts and is hydraulically balanced when assembled at the factory. Only those parts which are listed in parts book are replaceable and interchangeable. No other valve parts are individually interchangeable. If replacement of any non-serviceable valve part is necessary, the rotary valve assembly should be replaced.

1. If the valve assembly leaks externally between the torsion bar and stub shaft, the valve assembly should be replaced. The torsion bar O-ring seal in the stub shaft is not serviced.

2. Inspect the pin in the valve body that engages the valve cap for being badly worn, cracked, or broken. If the pin is damaged the valve assembly should be replaced.

3. Inspect the smaller of the two grooves in the end of valve body. If it is worn badly the valve assembly should be replaced.

4. Inspect the valve spool drive pin in the stub shaft. If it is worn badly, cracked or broken, the valve assembly should be replaced.

5. Examine the valve spool O.D. and the valve

body I.D. for nicks, burrs or bad wear spots. If any are found, the valve assembly should be replaced. A slight polishing is normal on the valving surfaces.

6. Check the fit of the spool in the valve body. Lubricate the spool with automatic transmission oil and install it in the valve body without the dampener O-ring seal on it. The spool should rotate smoothly without binding or catching. If spool does not rotate smoothly, the valve assembly should be replaced.

7. Measure the length of the valve spool spring. The free length should be approximately  $3/4$  to  $7/8$  inch. If it measures  $11/16$  inch or less, the spring should be replaced because this indicates that the spring has taken a set.

8. Examine the needle bearing surface on the stub shaft for being badly worn, brinelled or scored. If damaged, the valve assembly should be replaced.

#### g. Reassembly of Rotary Valve Assembly

**CAUTION:** All parts must be free and clear of dirt, chips, etc., before assembly and must be protected after assembly.

1. If removed from valve body, lubricate three new ring back-up O-ring seals in automatic transmission oil and assemble in the three ring grooves on the valve body. Assemble three new valve body rings in the ring grooves over the O-ring seals by carefully slipping over the valve body. See Figure 8-47.

**NOTE:** The valve body rings may appear loose or twisted in the grooves, but the heat of the oil during operation after assembly will cause them to straighten.

2. Lubricate a new valve dampener O-ring

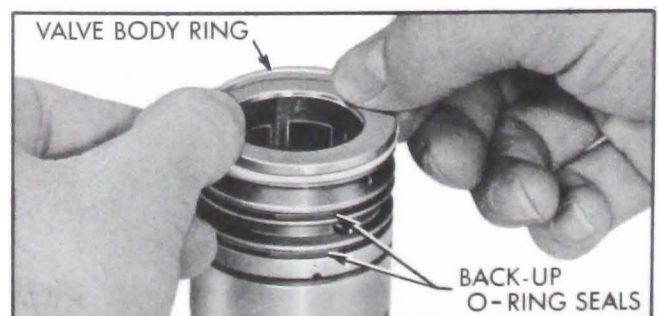

Figure 8-47—Installing Valve Body Rings



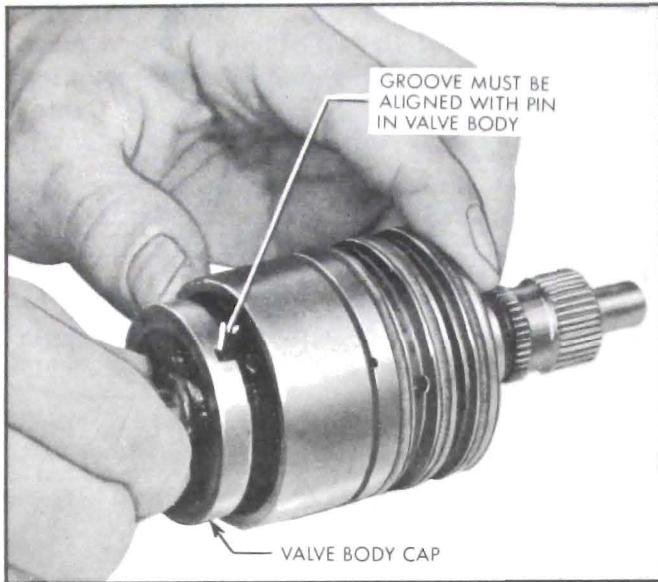

Figure 8-48—Assembling Valve Assembly

seal in automatic transmission oil and install in valve spool groove.

3. Assemble the stub shaft torsion bar and cap assembly in the valve body, aligning the groove in the valve cap with the pin in the valve body. See Figure 8-48. Tap lightly on the cap with a soft mallet until cap is against the shoulder in the valve body. Valve body pin must be in the cap groove. Hold these parts together during the rest of valve assembly.

4. Lubricate valve spool with automatic transmission oil. With notch in spool toward valve body, slide the spool over the stub shaft. Align the notch on the valve spool with the spool drive pin on the stub shaft and carefully engage the spool in the valve body bore. Push the spool evenly and slowly with a slight rotating motion until spool reaches drive pin. Rotate spool slowly with pressure until the notch engages the pin. Before pushing the spool completely in, make sure dampener O-ring seal is evenly distributed in the spool groove. Complete the spool assembly slowly with care so the O-ring seal is not damaged.

**CAUTION:** Because the clearance between the spool and valve body is very small, extreme care must be taken when assembling these parts.

5. Place seal protector J-6222 over stub shaft and slide valve spool spring over stub shaft with smaller diameter coil going over end of shaft last. See Figure 8-49. Work spring on shaft with a screw driver until small coil of spring is seated in the stub shaft groove. Be careful not to damage surface of shaft.

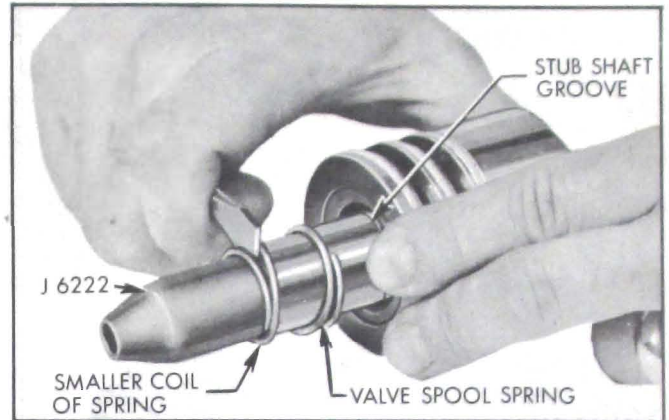

Figure 8-49—Installing Valve Spool Spring

**NOTE:** Spring must be seated properly in groove in stub shaft.

6. Lubricate a new cap to worm O-ring seal in automatic transmission oil and install in valve body.

**NOTE:** If during the assembly of the valve, the stub shaft and valve cap were allowed to slip out of engagement with the valve body pin, the spool will be permitted to enter the valve body too far. The spool dampener O-ring seal will expand into the valve body oil slots and will prevent withdrawal of the spool. If this has occurred, attempt to withdraw spool with a slight pull and much rotary motion. If this does not free the spool make sure spool is free to rotate and place valve body on a flat surface with notched end up. Tap spool with wooden or plastic rod until O-ring seal is cut and spool can be removed. Install new dampener O-ring seal and proceed with assembly as before starting with Step 2 above.

#### **h. Installation of Rotary Valve Assembly and Adjuster Plug Assembly**

1. Align the narrow pin slot on the valve body with the valve body drive pin on the worm. Insert the valve assembly into the gear housing by pressing against the valve body with the finger tips. Do not press on stub shaft or torsion bar. See Figure 8-50. The return hole in the gear housing should be fully visible when valve is assembled properly. See Figure 8-51.

**CAUTION:** Do not push against the stub shaft during assembly as this may cause the stub shaft and cap to pull out of the valve body, allowing the spool dampener O-ring seal to slip into valve body oil grooves. Be sure valve is properly seated before installing adjuster plug assembly.

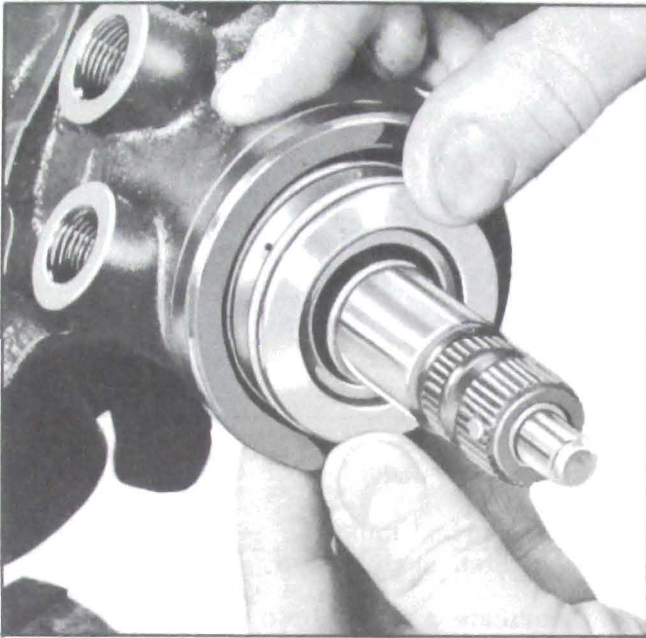

Figure 8-50—Installing Valve Assembly in Housing

2. Place seal protector J-6222 over end of stub shaft. Install adjuster plug assembly in gear housing snugly with adjustable spanner wrench J-7624, then back plug off approximately 1/8 turn. Install adjuster plug lock nut if removed, but do not tighten.

3. Adjust the thrust bearing preload and check the ball preload and "overcenter" adjustment as instructed in par. 8-13, subpar. b.

4. Tighten adjuster plug lock nut with adjustable spanner wrench J-7624. Recheck thrust bearing preload to be sure that tightening lock nut did not change adjustment.

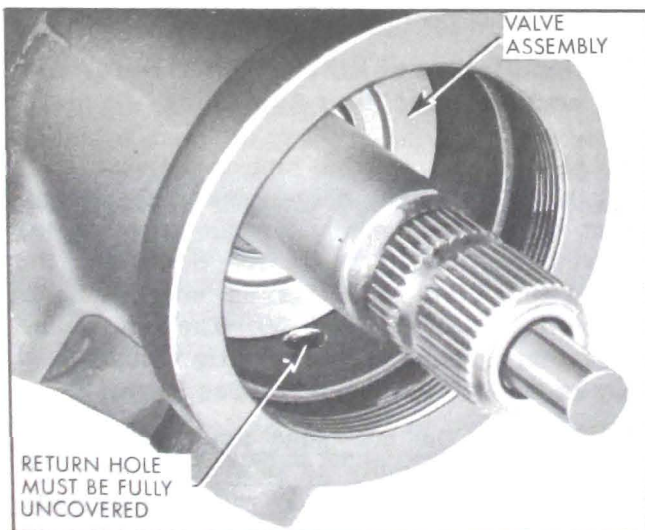

Figure 8-51—Valve Assembly Properly Installed in Housing

5. Align flat section in lower flange with flat on stub shaft and install flange. There must be at least 1/16" clearance between coupling and adjuster plug. See Figure 8-35. Center bolt hole on flange with groove on stub shaft.

**NOTE:** Do not install coupling at this time if gear is to be installed in Synchronesh equipped car.

6. Install lower flange pinch bolt and tighten to 30 ft. lbs.

## 8-15 DISASSEMBLY, INSPECTION AND ASSEMBLY OF PITMAN SHAFT ASSEMBLY

### a. Removal of Pitman Shaft Assembly

1. Thoroughly clean exterior of gear assembly with a suitable solvent. Drain the unit by placing the valve ports down and turning the worm through its entire range two or three times.

2. Rotate the stub shaft until pitman shaft gear is in center position (2 1/8 turns from extreme right position). Remove the housing side cover retaining bolts.

3. Tap the end of the pitman shaft with a soft mallet and slide shaft out of housing.

4. Remove the side cover O-ring seal and discard.

### b. Disassembly of Pitman Shaft Assembly

1. Remove the pitman shaft seal retaining ring from end of housing using No. 3 Truarc Pliers J-4245 and remove outer seal back-up washer. Tap a screw driver between the outer seal and the inner back-up washer and pry out seal. Tap the screw driver between the inner seal and the shoulder in the gear housing and pry out inner seal. Be careful not to damage the seal bore in housing. Discard seals.

2. Check the pitman shaft needle bearing for being worn, pitted or scored. If damaged, remove needle bearing from gear housing bore by driving from the seal bore side of housing using Tool J-6657. See Figure 8-52. Discard bearing.

3. Hold the lash adjuster with an Allen wrench and remove the lash adjuster nut. Discard nut. Remove side cover from lash adjuster.



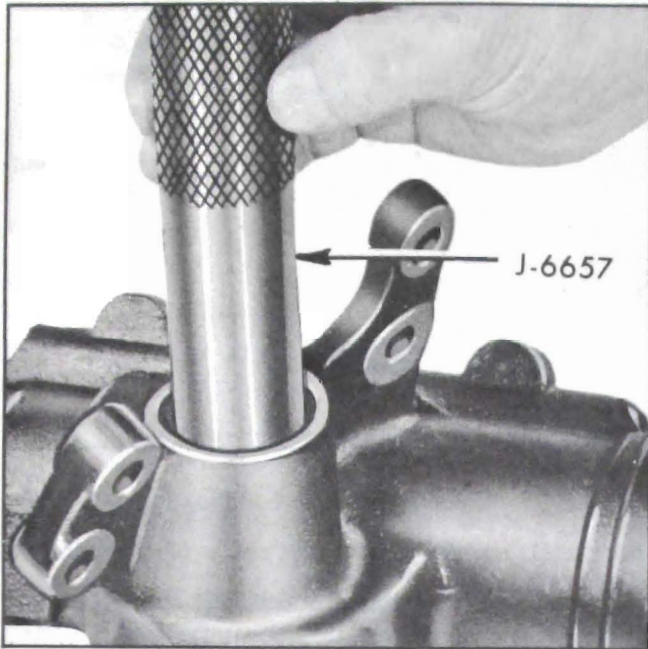

Figure 8-52—Removing Pitman Shaft Needle Bearing

### c. Inspection of Pitman Shaft Assembly

1. Inspect pitman shaft bushing surface in side cover for excessive wear or scoring. If worn or scored, replace side cover.
2. Check the pitman shaft sector teeth and the bearing and seal surfaces. If worn, pitted or scored, replace pitman shaft.
3. Check the torque on the lash adjuster. See Figure 8-53. If torque exceeds 15 inch pounds, pitman shaft assembly should be replaced.

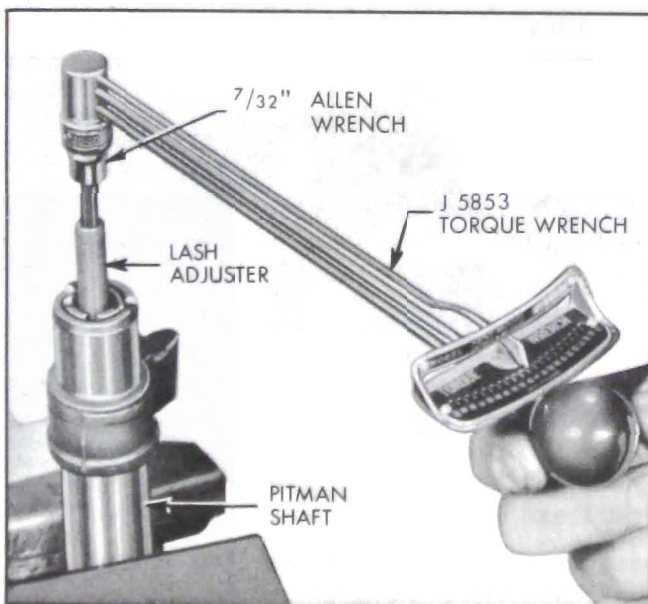

Figure 8-53—Checking Torque on Lash Adjuster

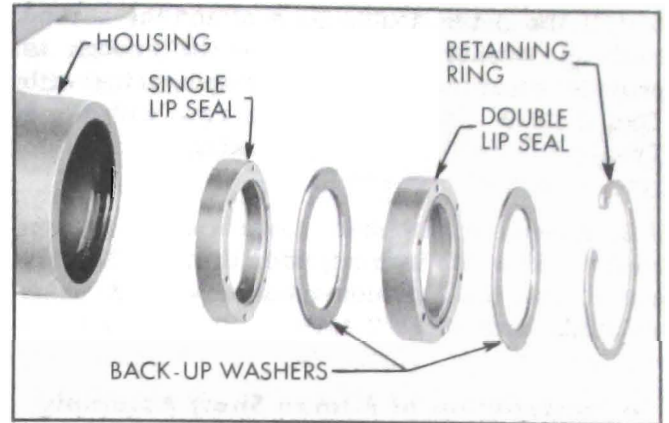

Figure 8-54—Pitman Shaft Seals

### d. Reassembly of Pitman Shaft Assembly

1. If pitman shaft needle bearing was removed because of damage, install new needle bearing into gear housing bore from seal bore end, pressing against stamped identification on bearing with Tool J-6657. Press in until bearing clears shoulder in gear housing, .030" maximum. Rollers in bearing must be free to rotate.
2. Lubricate new pitman shaft seals in automatic transmission oil. Install the inner, single lip seal in bore first, then a back-up washer. See Figure 8-54. Using Tool J-6219, drive the seal and washer in far enough to provide clearance for the outer seal, back-up washer and retaining ring. See Figure 8-55. The inner seal must not bottom on the counter bore.

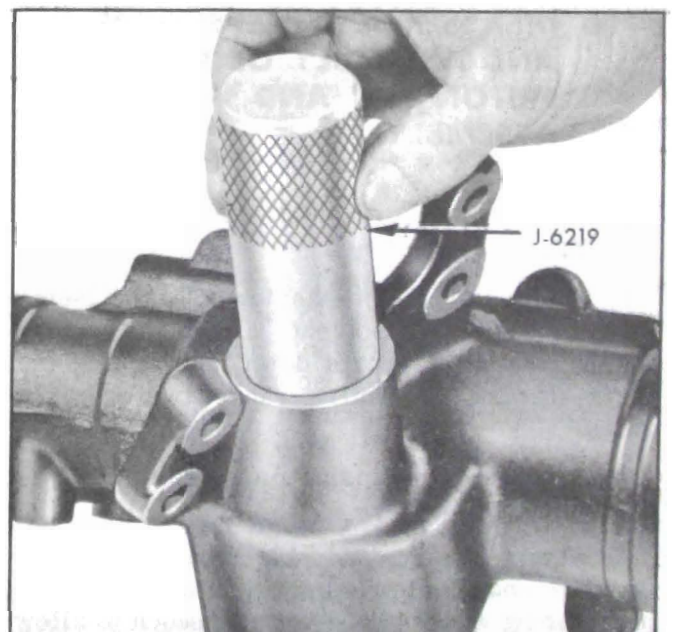

Figure 8-55—Installing Pitman Shaft Seals

Install the outer double lip seal and the second back-up washer in bore only far enough to provide clearance for the retaining ring with Tool J-6219. Install retaining ring with No. 3 Truarc Pliers Tool J-4245, making certain that ring is seated properly.

3. Assemble the side cover on the pitman shaft. Screw the lash adjuster through the side cover until the side cover bottoms on the shaft and then back off 1/2 turn.

#### **e. Installation of Pitman Shaft Assembly**

1. Lubricate a new side cover O-ring seal in automatic transmission oil and install in groove in the face of side cover.

2. Turn the stub shaft until the center groove of the rack-piston is aligned with the center of the pitman shaft hole.

3. Wrap masking tape over the end of pitman shaft. Install the pitman shaft so that the center tooth in the sector meshes with the center groove of the rack-piston nut. Make sure the side cover O-ring seal is in place before pushing the side cover down on gear housing. Remove masking tape from end of shaft.

4. Install the four side cover bolts with lock-washers and tighten to 30 ft. lbs.

5. Install new lash adjuster nut on lash adjuster, but do not tighten.

6. Adjust pitman shaft "overcenter" preload as outlined in par. 8-13 (b).

### **8-16 DISASSEMBLY, INSPECTION AND ASSEMBLY OF RACK-PISTON NUT AND WORM ASSEMBLY**

#### **a. Removal of Rack-Piston Nut and Worm Assembly**

1. Thoroughly clean exterior of gear assembly with a suitable solvent. Drain the unit by placing the valve ports down and turning the worm through its entire range two or three times.

2. Remove pitman shaft assembly as outlined in par. 8-15 (a).

3. Rotate housing end plug retainer ring so that one end of ring is over hole in gear housing. Spring one end of ring with punch to allow screw driver to be inserted to lift ring out. See Figure 8-56.

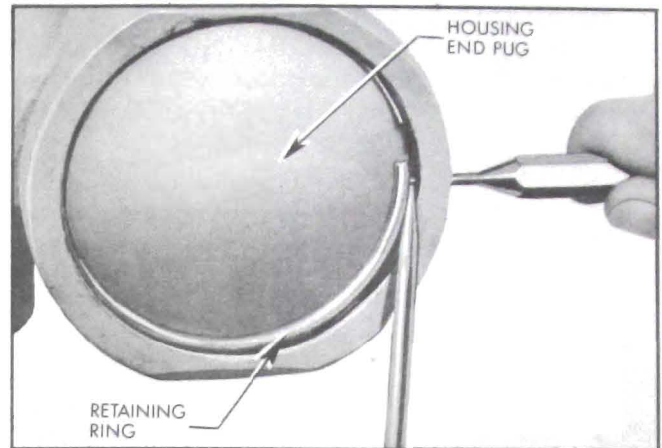

Figure 8-56—Removing Housing End Plug Retaining Plug

4. Rotate stub shaft to full left turn position to force end plug out of housing.

**CAUTION:** Do not rotate farther than necessary or the balls from the rack-piston and worm assembly will fall out.

5. Remove and discard housing end plug O-ring seal.

6. Remove rack-piston nut end plug retaining ring using No. 3 Truarc Pliers J-4245. Pull out rack-piston end plug with water pump pliers. See Figure 8-57.

7. Remove rack-piston nut end plug O-ring seal and discard.

8. Insert Ball Retaining Tool J-7539 in end of worm. See Figure 8-58. Turn stub shaft so that rack-piston nut will go onto the tool and remove rack-piston nut from gear housing. Keep

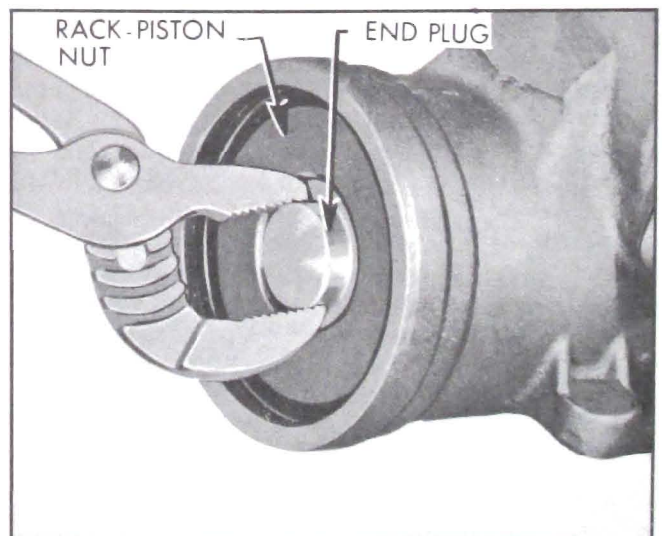

Figure 8-57—Removing Rack-Piston Nut End Plug



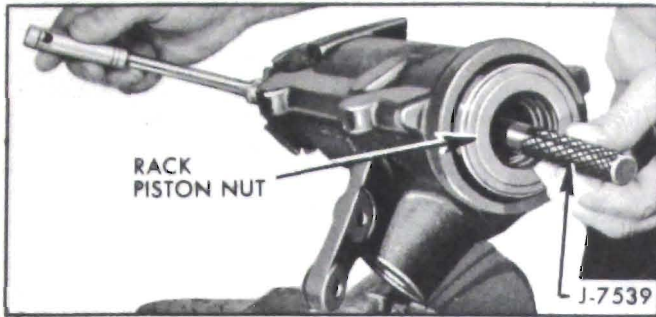

Figure 8-58—Removing Rack-Piston Nut From Housing

ball retaining tool completely through rack-piston nut to prevent balls from falling out.

9. Remove adjuster plug assembly and rotary valve assembly as outlined in par. 8-14(a).

10. Remove worm and lower thrust bearing and races.

11. Remove cap to worm O-ring seal and discard.

#### b. Disassembly of Rack-Piston Nut and Worm Assembly

1. Remove and discard piston ring and back-up O-ring on rack-piston nut.

2. Remove ball return guide clamp to rack-piston nut screws and lockwashers and remove clamp.

3. Place the rack-piston nut on a clean cloth and remove ball return guide and ball retaining tool. Make sure all 22 balls are caught on the cloth.

#### c. Inspection of Rack-Piston Nut and Worm Assembly

1. Inspect gear housing bore. If badly scored or worn, replace housing.

2. Inspect the worm and rack-piston nut grooves and all the balls for excessive wear or scoring. Inspect rack-piston nut teeth for pitting, wear or scoring. Inspect O.D. of rack-piston nut for wear, scoring or burrs. If either the worm or rack-piston nut need replacing, both must be replaced as a matched assembly.

3. Inspect ball return guides, making sure that the ends where the balls enter and leave the guides are not damaged. Replace if necessary.

4. Inspect lower thrust bearing and races for wear, pitting, scoring or cracking. Replace any damaged parts.

5. Inspect the hose connectors on gear housing. If badly brinelled or scored, replacement will be necessary. To remove the connectors, tap threads using 5/16-18 tap. Thread a bolt with a nut and flat washer into the tapped hole. Pull the connector by holding the bolt and turning the nut off the bolt. Wash and blow the housing out thoroughly to remove any tapping chips. To install new connector, use Replacer J-6217 to drive connector in place.

6. Check the operation of check valve poppet located under connector in pressure port of housing. Poppet should reseat itself against connector after being lightly pushed down. If poppet is not operating properly, remove connector, poppet and spring from pressure port. Then install a new spring with large end down, a new poppet with tangs pointed down. Install a new connector using Installer J-6217. Be sure new poppet operates properly.

7. Inspect the ball plug in gear housing. If it is leaking, or raised above the housing surface, it may be driven in flush to 1/16 inch below surface. The ball can be tightened by staking the housing. If the leakage cannot be stopped, the housing should be replaced.

#### d. Reassembly of Rack-Piston Nut and Worm Assembly

1. Thoroughly clean and lubricate the internal parts with automatic transmission oil.

2. Install new piston ring back-up O-ring in groove on rack-piston nut. Place a new piston ring over the back-up O-ring. See Figure 8-59.

3. Install worm into rack-piston nut to bearing shoulder.

4. Align the ball return guide holes in the rack-piston nut with the worm groove. Load 16 balls, 8 plain and 8 black in alternate sequence into the guide hole nearest the piston ring while slowly rotating worm counterclockwise. See Figure 8-60.

5. Fill one-half the ball return guide with the remaining 6 balls, 3 plain and 3 black balls in alternate sequence. Place the other half of guide over the balls and plug each end with heavy grease to prevent the balls from falling out when installing the guide to the rack-piston nut.

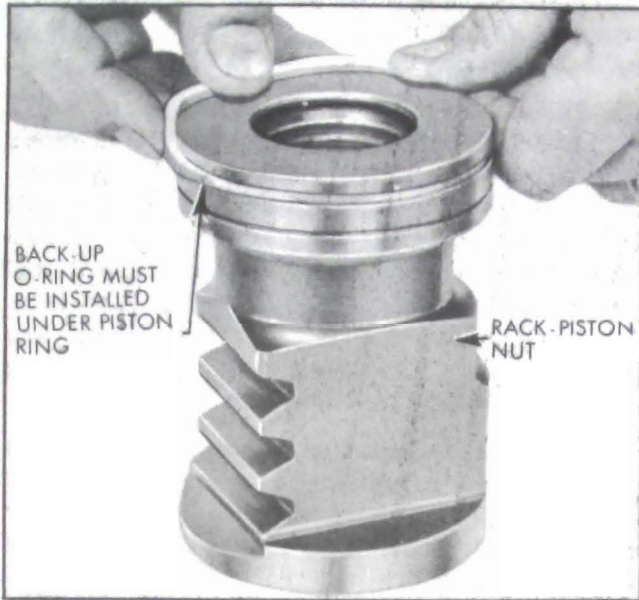

Figure 8-59—Installing Piston Ring on Rack-Piston Nut

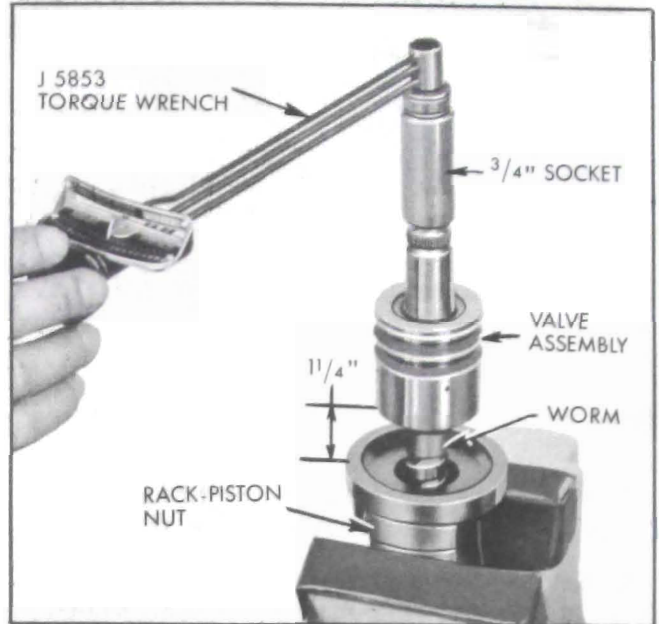

Figure 8-61—Checking Rack Piston Nut Ball Preload

6. Insert ball return guide into guide holes of the rack-piston nut so that balls in the guide alternate with the balls in the rack-piston nut. Guide should fit loosely.

7. Place clamp over guide and install 2 screws with special lockwashers and tighten.

8. The worm groove is ground with a high point in the center. When the rack-piston nut passes over this high point, a preload of 1 to 5 inch pounds should be obtained. To measure the preload of the assembly, lightly clamp rack-piston nut in a soft jaw vise with worm pointing up. Do not distort rack-piston nut by tightening too heavily. Place valve assembly on worm,

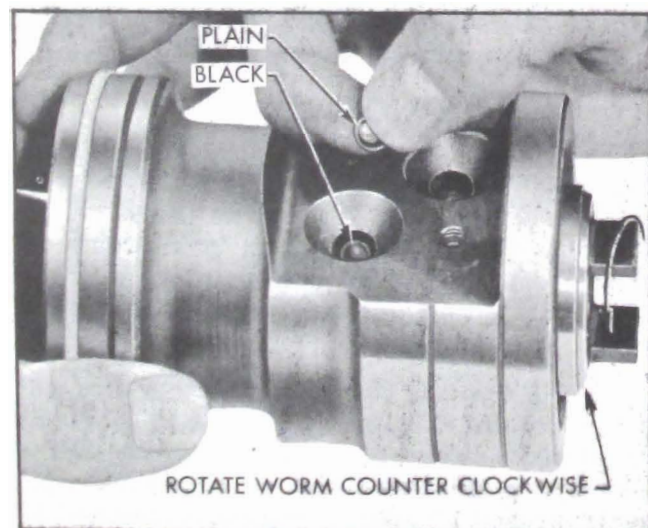

Figure 8-60—Loading Balls in Rack-Piston Nut

engaging worm drive pin. Rotate the worm until it extends 1 1/4 inches from the edge of rack-piston nut to the thrust bearing face of worm; this is the center position.

Attach torque wrench J-5853 with 3/4 inch, 12 point socket to the stud shaft. See Figure 8-61. Rotate the wrench through a total arc of approximately 60 degrees (1/6 turn) in both directions several times and take a reading. The highest reading obtained with the worm rotating should be from 1 to 5 inch pounds. If the reading is too high, disassemble and reassemble, using the next size smaller plain balls and recheck. (A rack-piston nut with a ball size of 7 does not have a number stamped on the flat surface. For ball sizes other than 7, the ball size is stamped on the flat surface of the rack-piston nut.) If the reading is too small, use the next size larger plain balls and recheck. See par. 8-8, subpar. b for ball size. Remove valve assembly from worm.

9. Turn the rack-piston nut and worm assembly to a horizontal position in the vise and insert ball retaining tool J-7539 in end of worm and turn worm out of the rack-piston nut. Do not allow the tool to separate from the worm until worm is fully removed from rack-piston nut.

#### e. Installation of Rack-Piston Nut and Worm Assembly

1. Assemble lower thrust bearing (1" I.D. x 1 5/8" O.D.) and races on worm. Install new



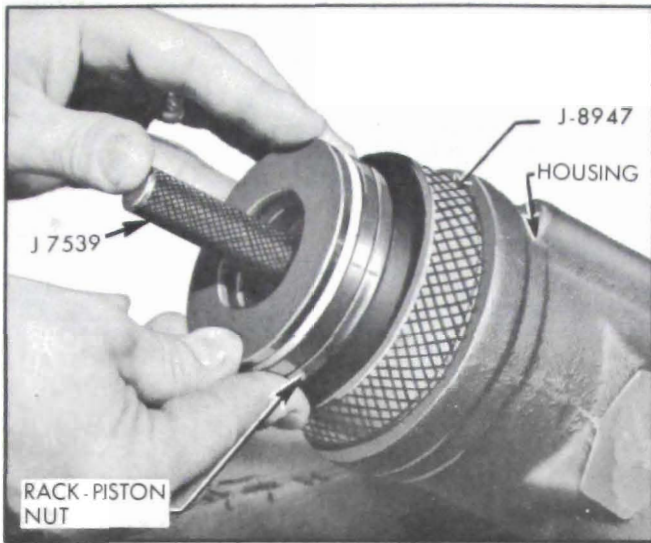

Figure 8-62—Installing Rack-Piston Nut in Housing

cap to worm O-ring seal. Assemble rotary valve assembly to worm by aligning narrow pin slot in valve body with pin on worm.

2. Insert the valve assembly and worm in gear housing as an integral unit. Do not press on stub shaft or torsion bar. See Figure 8-50. Return hole in housing should be fully visible when valve and worm are properly installed. See Figure 8-51.

3. Place seal protector J-6222 over end of stub shaft. Install adjuster plug assembly in gear housing snugly with adjustable spanner wrench J-7624, then back plug off approximately 1/8 turn. Install adjuster plug lock nut if removed, but do not tighten.

4. Adjust the thrust bearing preload. Using torque wrench J-5853, rotate stud shaft to measure valve assembly drag. See Figure 8-33. Then tighten adjuster plug to obtain a reading 1 to 3 inch lbs. in excess of valve drag. Total of thrust bearing preload and valve drag should not exceed 11 inch pounds.

5. Tighten adjuster plug lock nut. Recheck thrust bearing preload to be sure that tightening lock nut did not change adjustment.

6. Install ring compressor sleeve tool J-8947 in gear housing and hold it tightly against shoulder in the housing. See Figure 8-62. Insert the rack-piston nut into the housing until the ball retaining tool J-7539 engages the worm. Turn the stub shaft, drawing the rack-piston nut into the housing. When the piston ring is into the housing bore, the ball retaining tool and the ring compressor may be removed.

7. Lubricate a new rack-piston end plug O-ring seal with automatic transmission oil and install on end plug. Do not allow O-ring to twist in groove.

8. Install rack-piston end plug in rack-piston nut and tap into place with a soft mallet.

9. Install rack-piston end plug retaining ring using No. 3 Truarc Pliers J-4245. Make sure ring is securely bottomed in groove.

10. Lubricate housing end plug O-ring seal with automatic transmission oil and install in gear housing.

11. Insert end plug into gear housing and seat against O-ring seal. Slight tapping with a soft mallet may be necessary to seat plug properly. Install end plug retainer ring.

12. Install pitman shaft assembly as outlined in par. 8-15, subpar. e, Steps 1 through 5.

13. Turn lash adjuster counterclockwise a few turns and obtain a reading with torque wrench J-5853 while rotating stub shaft through "high point" range (2 1/8 turns from either extreme). Adjust lash adjuster to obtain a reading 4 to 8 in. lbs. higher than first reading. Tighten lash adjuster nut.

14. Align flat section in lower flange with flat on stub shaft and install flange. There must be at least 1/16" clearance between coupling and adjuster plug. See Figure 8-35. Center bolt hole on flange with groove on stub shaft. Install pinch bolt and tighten to 30 ft. lbs.

**NOTE:** Do not install coupling at this time if gear is to be installed in Synchronesh equipped car.

## 8-17 DISASSEMBLY, INSPECTION AND ASSEMBLY OF POWER STEERING OIL PUMP

Refer to par. 8-12 for removal and installation of oil pump.

### a. Disassembly of Oil Pump

It is not necessary to disassemble pump to replace shaft seal. To remove seal, punch a small hole in metal surface of seal and thread a sheet metal screw into hole. Then place side cutters under head of screw and tap out seal. See Figure 8-63. Lubricate new seal with automatic transmission oil and install as shown in Figure 8-72.

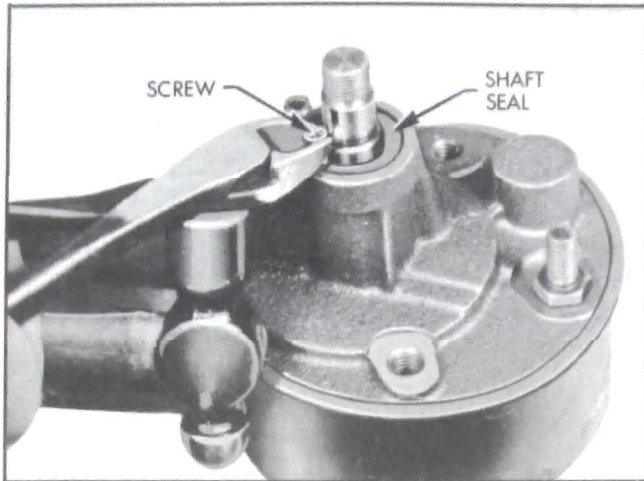

Figure 8-63—Removing Shaft Seal Without Disassembling Pump

1. Use shipping caps to cover the hose union and return pipe on pump and thoroughly clean exterior of pump.
2. Remove pump pulley key from pump shaft.
3. Remove reservoir cap and drain out oil in pump reservoir.
4. Install pump in a soft jaw vise with pump shaft pointing down. Do not clamp pump too tightly as this may distort bushing.
5. Remove the reservoir to pump housing stud and bolt with spacer.
6. Remove pressure union. Remove O-ring from union and discard.
7. Remove reservoir from housing by rotating reservoir counterclockwise (approximately 30 degrees) until reservoir can be lifted freely from housing. See Figure 8-64.
8. Remove and discard the large reservoir O-ring seal, the housing to reservoir seal and

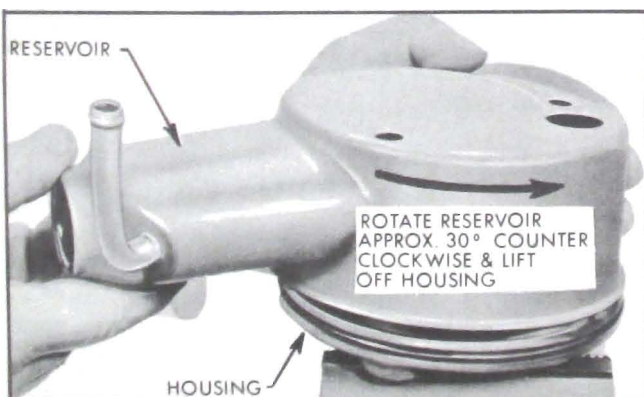

Figure 8-64—Removing Reservoir from Housing

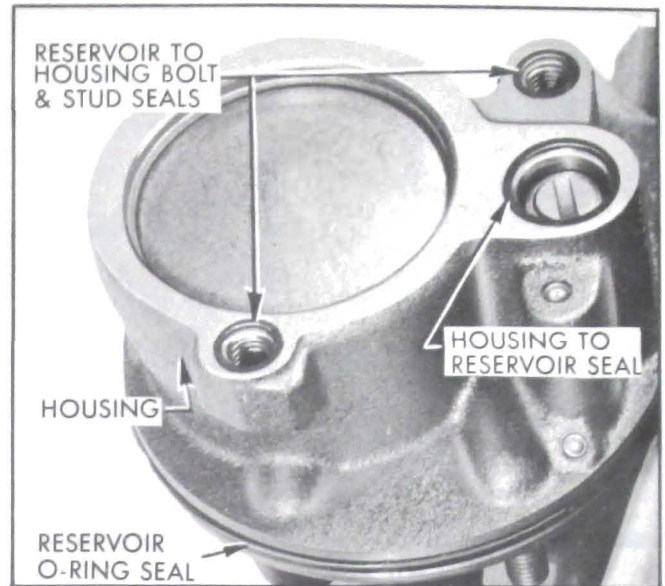

Figure 8-65—Housing to Reservoir Seals

the housing to reservoir bolt and stud seals. See Figure 8-65.

9. Rotate end plate retaining ring until one end of ring is over hole in housing. Spring one end of ring with 1/8" punch to allow screw driver to be inserted and lift ring out. See Figure 8-66.
10. Remove pump from vise and remove end plate, pressure plate spring, flow control valve and spring by turning pump over. If end plate should stick in housing, lightly tap it to align and free it.

**NOTE:** Do not disassemble flow control valve.

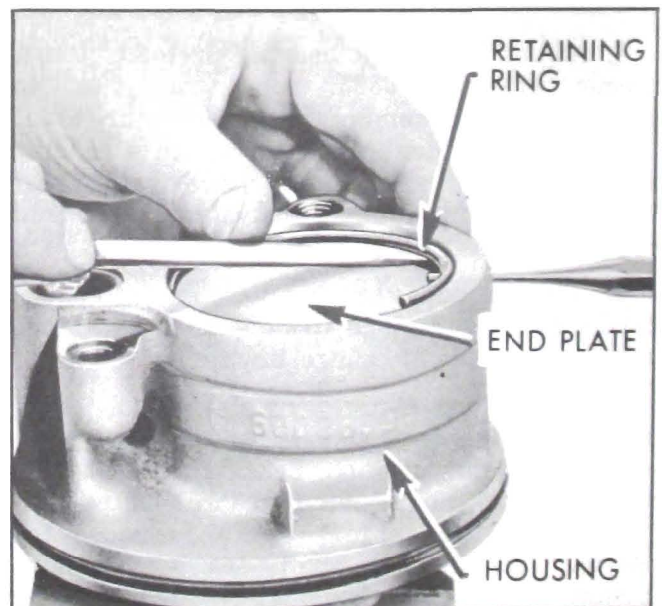

Figure 8-66—Removing End Plate Retaining Ring



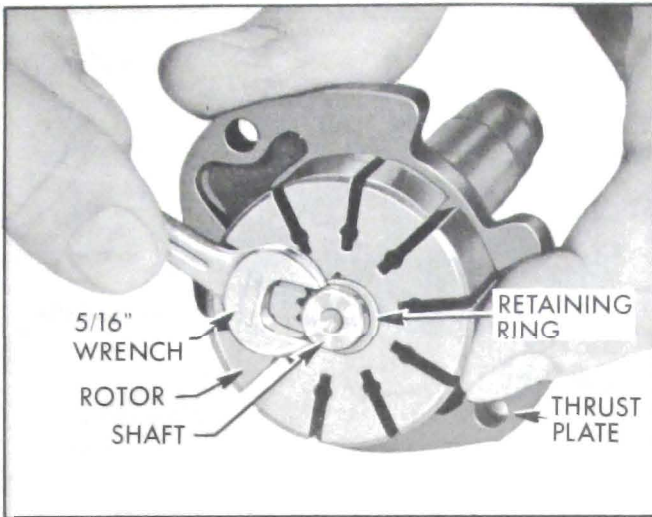

Figure 8-67—Removing Shaft Retaining Ring

11. Remove and discard end plate O-ring seal.

12. Place shaft end on bench and press down on housing until shaft is free. Turn housing over and remove shaft and rotor assembly, being careful not to drop parts. Remove vanes and pump ring from rotor. If the two dowel pins did not come out with assembly, it is not necessary to remove them from housing.

13. Remove shaft retaining ring from end of shaft with a 5/16" open end wrench, being careful not to damage rotor. See Figure 8-67. Remove rotor and thrust plate from shaft.

14. Remove and discard pressure plate O-ring seal.

15. Remove shaft seal, if defective, by prying out with small screw driver. Be careful not to damage pump housing or shaft bushing.

### b. Inspection of Oil Pump Parts

Clean all parts thoroughly with solvent and wipe dry with clean, lint-free cloth before inspecting.

1. Inspect shaft for wear.

2. Check fit of the ten vanes in slots of rotor; vanes must slide freely but fit snugly in slots. Tightness may be removed by thorough cleaning or removal of irregularities using a hard Arkansas stone. Replace rotor if excessive looseness exists between rotor and vanes and replace vanes if they are irregularly worn or scored. Light scoring on the rotor can be repaired by carefully lapping surface of rotor.

3. Inspect all ground surfaces of the pump ring for roughness or irregular wear. Slight irregularities may be removed with a hard Arkansas stone. Replace ring if inside cam surface is scored or worn and inspect outside radius of vanes very closely for damage.

4. Inspect the surfaces of the pressure plate and thrust plate for wear or scoring. Light scoring can be repaired by carefully lapping until surface is smooth and flat, after which all lapping compound must be thoroughly washed away.

5. Inspect the flow control valve bore in the housing for scoring, burrs or other damage. Hair line scratches are normal. Inspect bushing in housing, if worn or scored, replace housing.

6. Inspect the surfaces of the flow control valve for scores and burrs. Hair line scratches are normal. Replace valve if badly scored or if it is the cause of low pump pressure. Check the screw in the end of the valve, if loose, tighten to 10 ft. lbs., being careful not to damage machined surfaces. Filter in screw must not be plugged.

7. Check orifice in pressure union to be sure it is not plugged.

### c. Assembly of Oil Pump

1. Make sure all parts are absolutely clean. Lubricate seals and moving parts with automatic transmission oil during assembly.

2. Mount housing in vise with shaft end down. Install new pressure plate O-ring seal in groove in housing bore. The pressure plate and end plate O-ring seals are the same size.

3. Assemble shaft to thrust plate (ported face of thrust plate toward splined end of shaft) and rotor. See Figure 8-69. Install retaining ring on end of shaft, being careful not to damage rotor. Rotor must be free on shaft splines.

4. Install the two dowel pins in housing, if removed.

5. Line up holes in thrust plate with dowel pins and insert shaft, thrust plate and rotor assembly in housing. Press down on end of shaft to properly seat parts. If shaft seal was not removed, be careful not to damage seal.

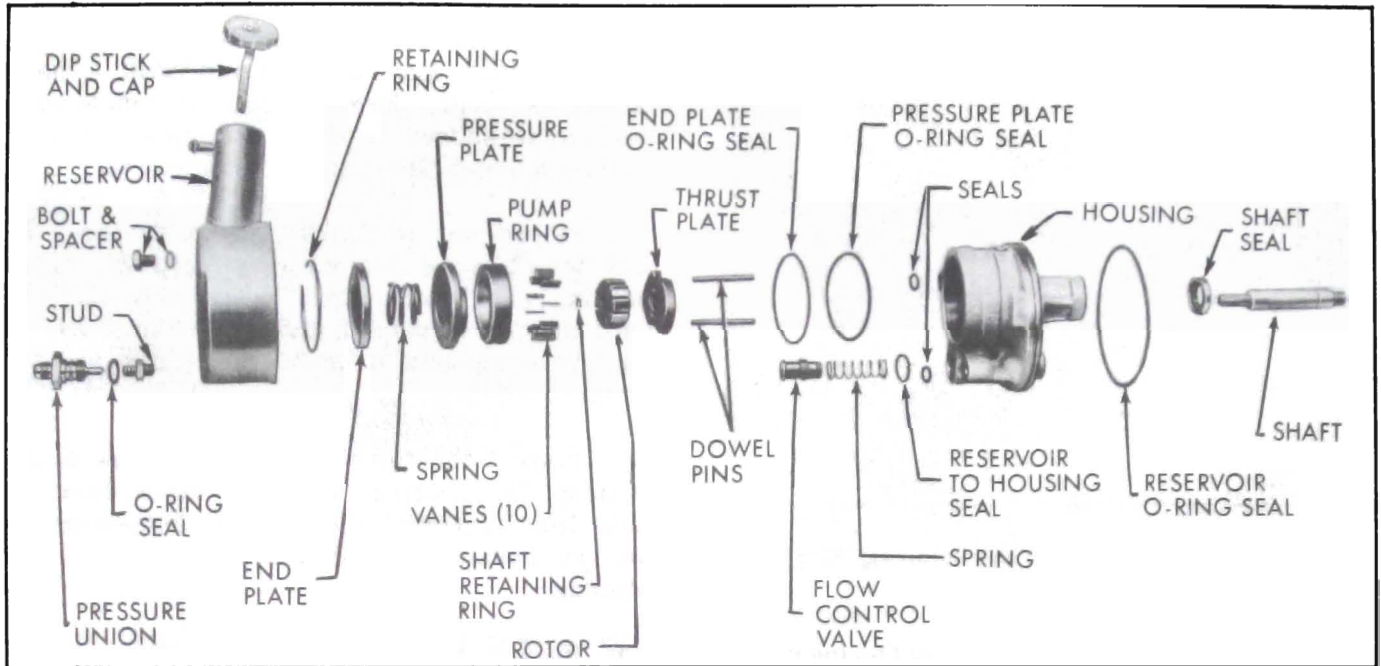

Figure 8-68—Exploded View of Oil Pump

6. Install pump ring with small holes in ring on dowel pins and with arrow on outer edge to rear of housing.

7. Install ten vanes in rotor slots with radius edge toward outside and flat edge toward center of rotor.

8. Lubricate the outside diameter and chamber of pressure plate with petroleum jelly and install on dowel pins with ported face toward pump ring. Dowel pins fit into slots in plate

that are nearest outside diameter of plate. Use a soft plastic or wood rod and lightly tap around outside diameter of pressure plate to seat it. See Figure 8-70. Pressure plate will travel about 1/16" to seat. Never press or hammer on the center of pressure plate as this will cause permanent distortion and result in pump failure.

9. Install new end plate O-ring seal in groove in bore of housing. Be sure not to install it in end plate retaining ring groove which is first groove from rear of housing. See Figure 8-70.

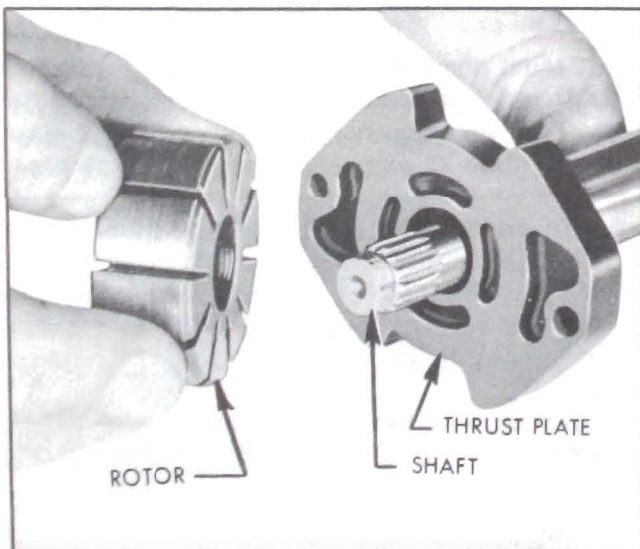

Figure 8-69—Assembling Shaft to Thrust Plate and Rotor

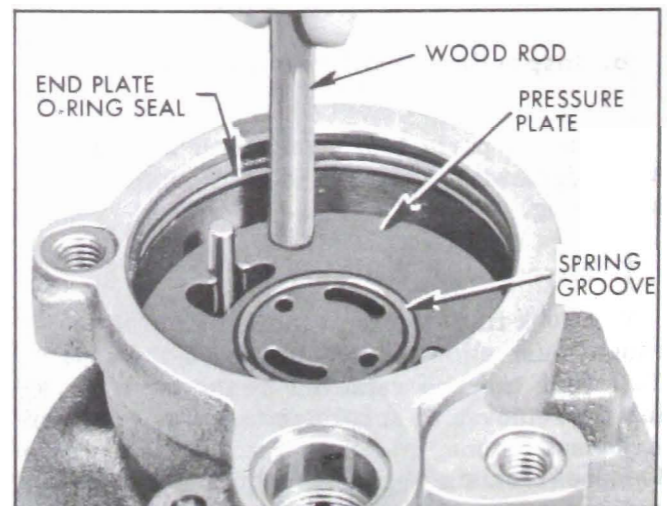

Figure 8-70—Seating Pressure Plate in Housing



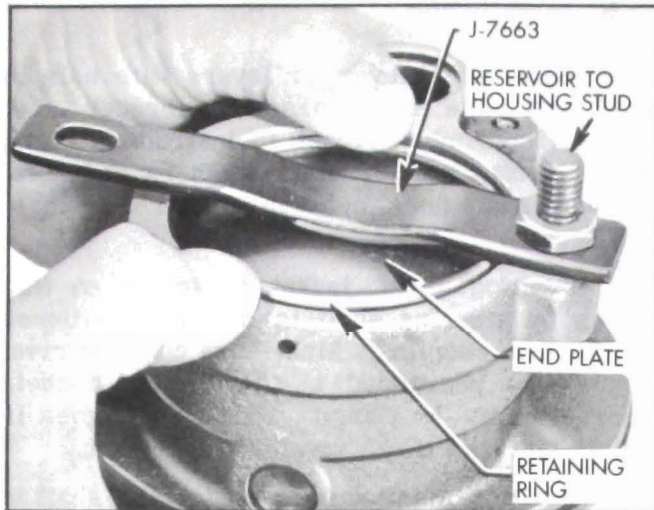

Figure 8-71—Installing End Plate

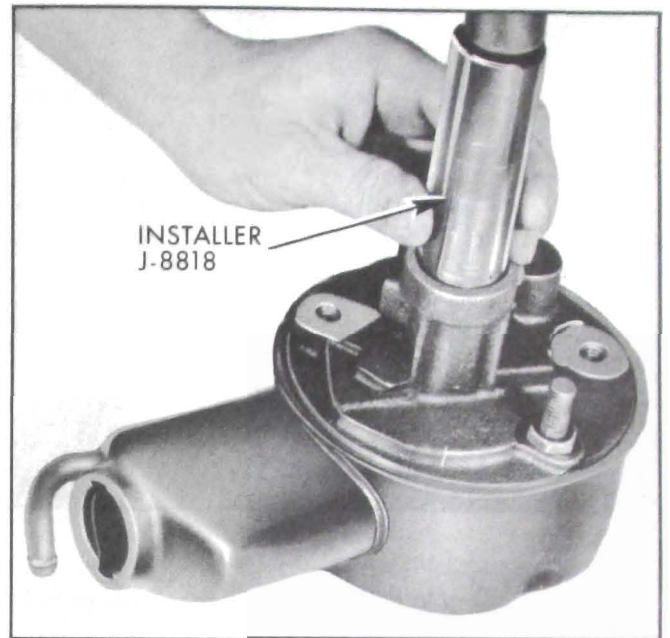

Figure 8-72—Installing Shaft Seal

10. Place pressure plate spring in center groove in pressure plate. See Figure 8-70.

11. Lubricate outside diameter and chamfer of end plate with petroleum jelly and insert in housing. Place retaining ring on top of end plate and position Installer J-7663 so that depression of installer is against center of end plate. See Figure 8-71. Attach installer to housing (not slotted end) using the reservoir to housing stud with long end of stud threading into housing. Press end plate down by tightening stud until ring groove in housing is evenly exposed. It may be necessary to press down slotted end of installer when tightening stud to prevent end plate from cocking in housing.

12. Install retaining ring, being sure that ring is completely seated in housing groove and end plate is aligned properly. See Figure 8-71.

13. Install a new reservoir O-ring seal on housing. Place a new reservoir to housing seal and new reservoir to housing bolt and stud seals in counter bores in housing. See Figure 8-65.

14. Position reservoir on housing so that filler tube is approximately 30 degrees counter-clockwise of correct position. Lower reservoir down on housing and rotate it clockwise to its correct position (holes in reservoir line up with holes in housing). Press reservoir down to properly seat on housing being careful not to damage seals on housing.

**CAUTION:** Do not use hammer or use bolt and stud to seat reservoir on housing.

15. Install reservoir to housing stud and bolt with spacer. Bolt goes in hole near top of pump. Tighten to 30 ft. lbs.

16. Install flow control spring. Then install flow control valve with screw head of valve going in housing first.

17. Assemble new O-ring in groove nearest outlet end of pressure union and install union in pump. Tighten to 20 ft. lbs.

**CAUTION:** If O-ring is installed in groove on pressure union that contains the orifice, pump will not build-up sufficient pressure.

18. Remove pump from vise. If shaft seal was removed, lubricate new seal with automatic transmission oil and drive in housing spring side first with Installer J-8818. See Figure 8-72. Just bottom seal in housing. Excessive force must not be used when driving seal in place.

19. Install pulley drive key on shaft. Support shaft on opposite side while installing key.

20. Check for bind in pump by rotating drive shaft. Shaft must rotate freely by hand.

## 8-18 REMOVAL AND INSTALLATION OF STEERING MAST JACKET ASSEMBLY

### a. Removal

1. Remove two nuts holding flexible coupling to steering shaft flange.



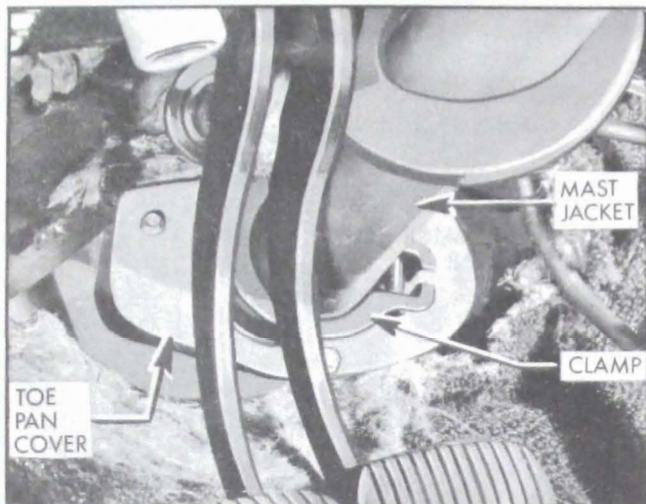

Figure 8-73—Mast Jack Attachment - Lower End

2. Remove lock key from each shift rod and pull rods out of shift levers.

3. Remove the screws that retain toe pan cover to cowl. See Figure 8-73.

4. Remove the U-bolt and mast jacket saddle (9/16" deep socket). See Figure 8-74.

5. Disconnect Wiring Harness Connectors from mast jacket and disconnect horn wire.

6. Align shift lever or levers with hole in cowl and remove jacket assembly.

### b. Installation

1. Align shift lever or levers with hole in cowl and slide end of assembly through hole. Loosely assemble jacket to instrument panel with U-bolt, saddle, plain washers and nuts. Rubber seal goes between U-bolt and mast jacket.

2. Position mast jacket assembly so that flange on steering shaft is properly positioned on flexible coupling. Make sure coupling rivet heads are positioned in the center of their correct slots in flange. Small rivet goes in small slot and large rivet in large slot.

3. Position mast jacket so steering shaft is in center of lower end of assembly. See Figure 8-75. Attach toe pan cover to cowl. If toe pan does not line up with attaching holes in cowl when steering shaft is correctly aligned, it will be necessary to drill new holes in cowl.

4. Place tang of mast jacket saddle in slot in jacket and tighten U-bolt nuts. See Figure 8-74.

5. Plug wiring harness connectors on switches on mast jacket and connect horn wire.

6. Install the two nuts and lock washers on the bolts that retain flexible coupling to steering shaft flange. Flange must not contact rivets and horn ground wire must be on bolt between flexible coupling and flange.

7. Attach each shift rod to shift lever with lock key.

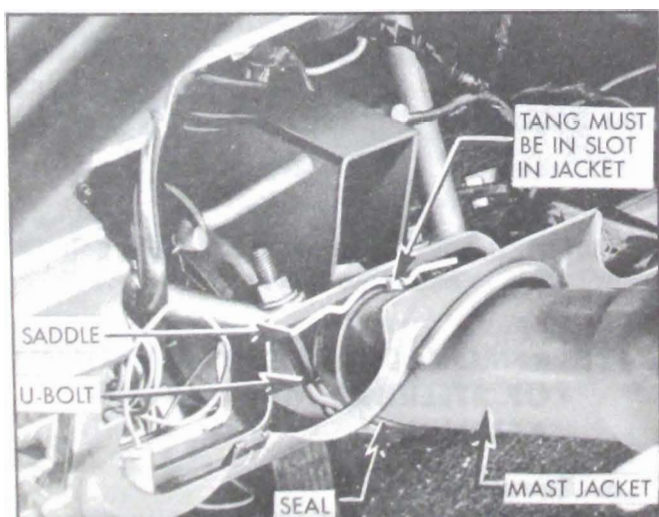

Figure 8-74—Mast Jacket Attachment - Upper End

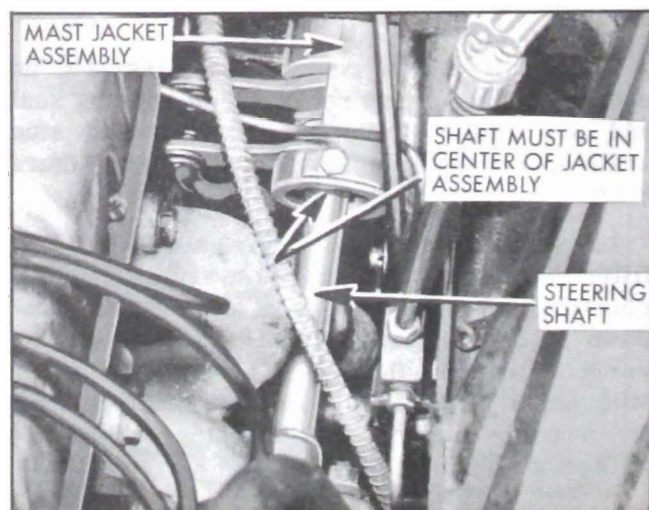

Figure 8-75—Steering Shaft to Mast Jacket Alignment

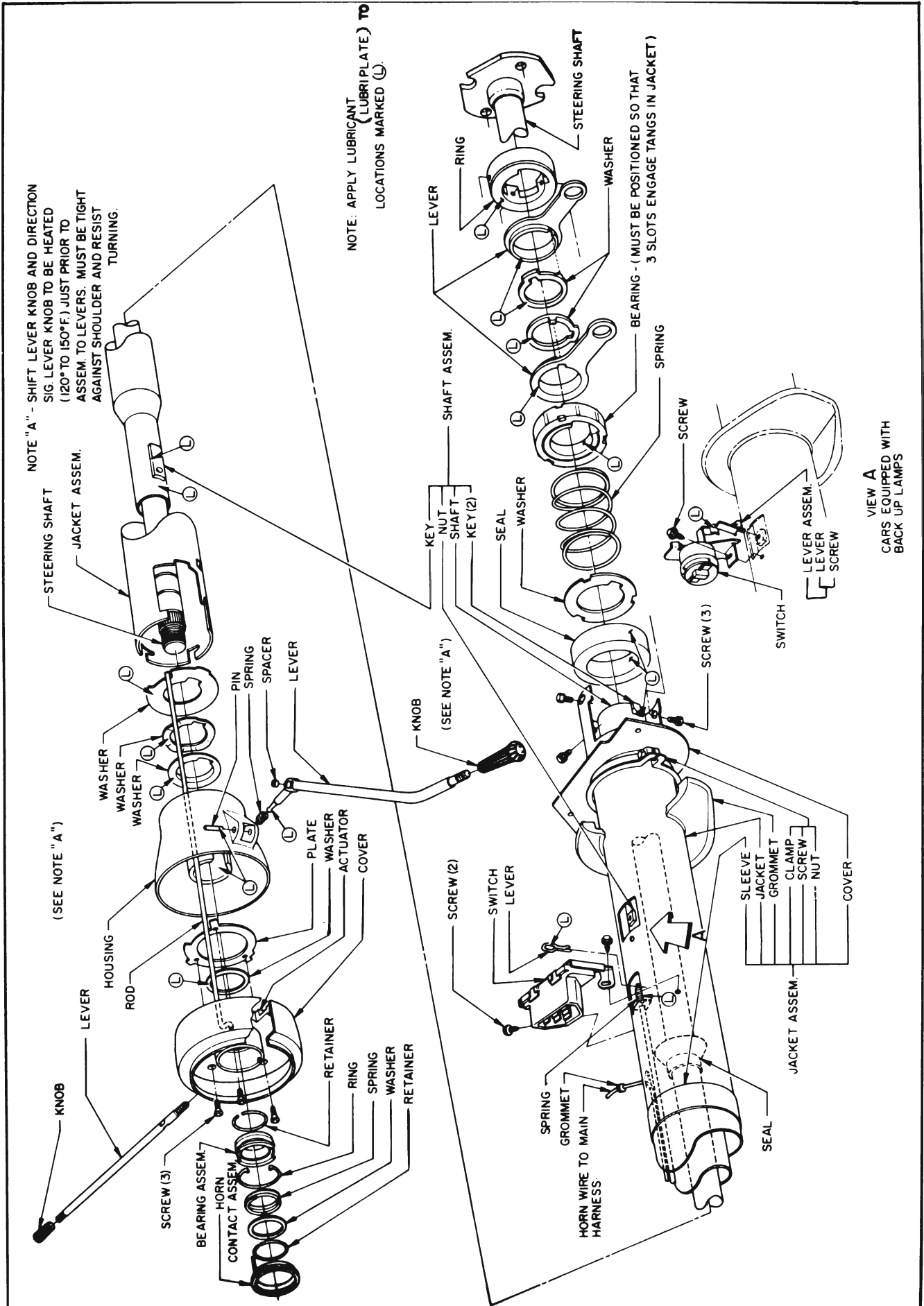
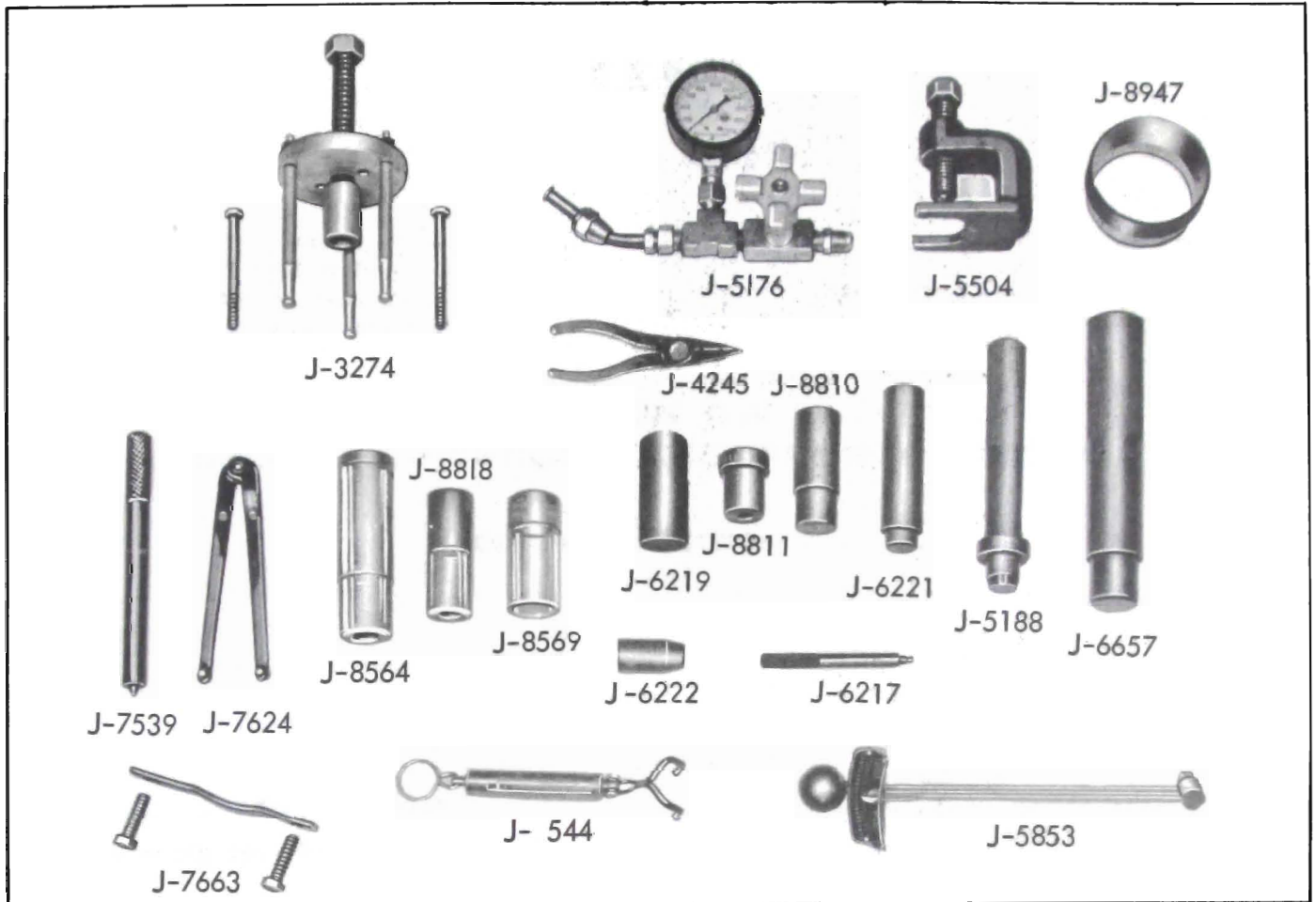

Figure 8-76—Mast Jacket and Transmission Control Shaft Assembly - Synchromesh Transmission







## STEERING TOOLS

- J- 544 Steering Gear Tension Scale 0-4 lbs.
- J-3274 Steering Wheel Puller
- J-4245 Trueare Pliers
- J-5176 Testing Gauge
- J-5188 Valve Cover Seal Installer
- J-5504 Pitman Arm Puller
- J-5854 0-100 in. lb. Torque Wrench
- J-6217 Valve Connector Seal Installer
- J-6219 Steering Gear Pitman Shaft Oil Seal Installer
- J-6221 End Cover Bearing Remover and Installer (Adjuster Plug Needle Bearing)
- J-6222 End Cover Seal Protector (Stub Shaft Protector)
- J 6657 Pitman Shaft Needle Bearing Remover and Installer
- J-7539 Power Steering Gear Ball Retaining Tool
- J-7624 Power Steering Gear Adjustable Spanner Wrench
- J-7663 Power Steering Pump End Plate Installer
- J-8564 Worm Shaft Oil Seal Installer
- J-8569 Pitman Shaft Oil Seal Installer
- J-8810 Pitman Shaft Bushing Remover and Replacer
- J-8811 Pitman Shaft Seal and Upper Bearing Cup Installer
- J-8818 Power Steering Pump Seal Installer
- J-8947 Teflon Ring Compressor

Figure 8-78—Manual and Power Steering Special Tools