

SECTION 3-E

ROCHESTER 2-BARREL CARBURETOR

CONTENTS OF SECTION 3-E

Paragraph	Subject	Page	Paragraph	Subject	Page
3-14	Description and Operation of Rochester 2-Barrel Carburetor	3-28	3-16	Assembly and Internal Adjustment of Rochester 2-Barrel Carburetor	3-34
3-15	Disassembly, Cleaning and Inspection of Rochester 2-Barrel Carburetor	3-32	3-17	External Adjustment of Rochester 2-Barrel Carburetor	3-35

3-14 DESCRIPTION AND OPERATION OF ROCHESTER 2-BARREL CARBURETOR

a. General Description

The Rochester Model 2GC carburetor used on regular Series 4400 engines is of the side bowl design. The carburetor float bowl is located forward of the main bores of the carburetor. The carburetor is compact in design in that all of the fuel metering is centrally located. See Figure 3-16.

This carburetor uses a calibrated cluster design, which places in a removable assembly, the main well tubes, idle tubes, mixture passages, air bleeds and pump jets. This cluster can easily be removed for cleaning and inspection purposes. The cluster fits on a flat portion of the carburetor bowl at the side of the main venturii with a gasket underneath. The idle and main well tubes are permanently installed in the cluster body by means of a precision pressed fit and, therefore, cannot be

serviced separately. The main nozzles and idle tubes are suspended in the fuel in the main wells of the float bowl. This method of assembly and design serves to insulate the idle and main well tubes from engine heat, thus helping prevent heat expansion and percolation spillover during hot idle or when shutting off a hot engine.

The main metering jets are of the fixed type. Metering calibration is accomplished through a system of calibrated air bleeds which give the correct air/fuel mixtures throughout all operational ranges.

The Rochester Model 2GC carburetor employs the use of a vacuum operated power system for extra power when needed. Power mixtures are regulated by drop in engine manifold vacuum regardless of the degree of throttle opening. Thereby, additional fuel can be supplied for power mixtures according to the engine demands.

The pump system has a vented type pump plunger. This is accomplished by means of a vapor vent ball in the pump plunger head. By venting the pump plunger, any fuel vapors which form in the pump well are vented to the fuel bowl during "hot" engine operation. This insures that the pump well and passages will be primed with solid fuel at all times, thereby improving accelerator pump action.

The carburetor is externally vented through a capped vent hole located in the center of the carburetor air horn just above the float bowl. The external bowl vent dissipates any fuel vapors which may form in the fuel bowl during prolonged periods of hot idle and hot "soak". This feature greatly improves hot idle and hot engine starting.

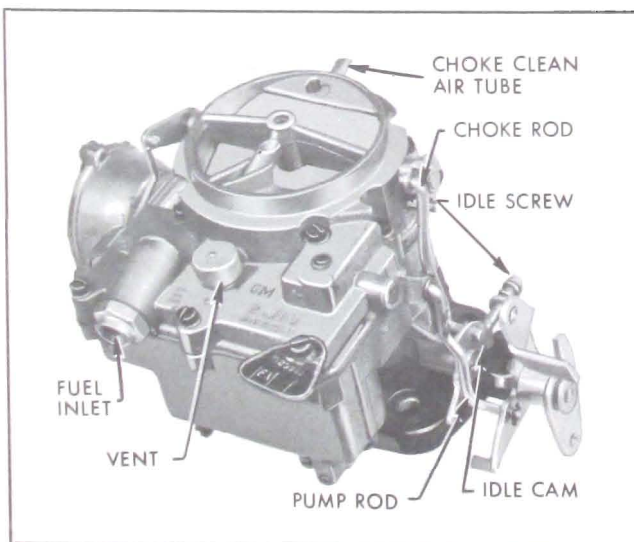

Figure 3-16—Rochester 2GC Carburetor Assembly

Adjustments have been made as simple as

possible. They consist of float level, float drop, pump, choke, fast idle cam, choke unloader and idle adjustments only.

Incorporated in the Rochester Model 2GC carburetor are six basic systems. They are Float, Low Speed, High Speed, Power, Accelerating and Choke systems. The following explanation and illustrations show that each system operates to provide efficient carburetion through all operating conditions.

b. Operation of Float System

The float system controls the level of the fuel in the carburetor fuel bowl. Fuel level is very important because it must be maintained to give proper metering through all carburetor ranges.

Fuel entering the carburetor must first pass through the inlet screen, by the inlet needle seat, then past the float needle, into the float bowl; flow continues until the fuel level raises the float to a position where it closes the float valve. As fuel is used from the carburetor bowl the float drops, moving the float needle off its seat and replenishing the fuel in the bowl, thereby keeping the fuel level constant. See Figure 3-17.

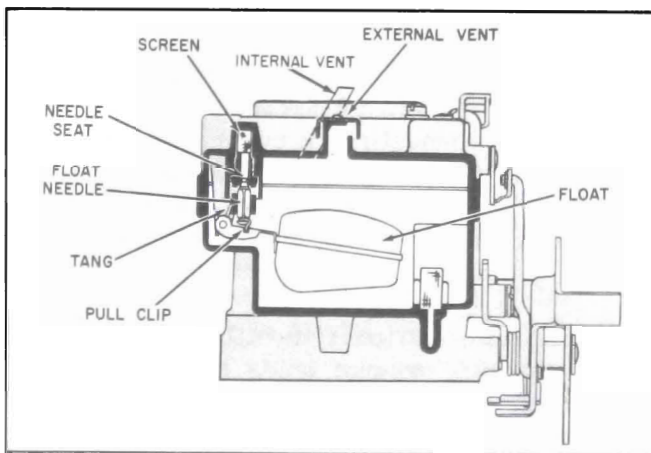

Figure 3-17—Float System

A float tang located at the rear of the float arm between the float hangers prevents the float assembly from moving too far downward, but allows the float assembly to move down far enough for maximum fuel flow into the carburetor bowl. A float needle pull clip connecting the float arm to the needle valve keeps the needle from sticking closed in the seat, which may be caused by dirt or gum formation.

An external vent located on the top of the carburetor air horn vents any fuel vapors which may form in the float bowl to the outside atmosphere during periods of hot engine operation. This helps prevent poor hot engine idling and hard hot engine starting.

c. Operation of Idle (Low Speed) System

During engine idle operation, air flow through the carburetor venturi is very low and is not great enough to cause fuel to flow from the main discharge nozzles. Therefore, the idle system is used to provide the proper mixture ratios required during idle and low speed operation of the engine.

The idle system consists of the idle tubes, idle passages, idle air bleeds, idle adjustment needles, idle discharge holes and the idle adjusting needle holes.

In idle speed position, the throttle valve is slightly open, allowing a small amount of air to pass between the wall of the carburetor bore and the edge of the throttle valve. Since there is not enough air flow for venturi action, the fuel is made to flow by the application of vacuum (low pressure) directly through the idle system to the fuel in the carburetor bowl. See Figure 3-18.

Fuel from the float bowl passes through the main metering jets into the main well where it is metered by the orifice at the lower end of the idle tube. It then passes up the idle tube and is mixed with air at the top of the idle tube by a calibrated idle air bleed. The air is bled a second time in the cross channel by a second idle air bleed. The air/fuel mixture then passes down through a calibrated restriction into a vertical passage to the secondary idle discharge holes located just above the throttle valves. Here the mixture is again bled with air and then moves down to the idle needle hole where it combines with air by-passing the slightly open throttle valve. The idle mixture needle controls the amount of fuel mixture which enters the carburetor bore at curb idle position of the throttle valves.

As the throttle valves are opened further, the lower idle discharge holes are consecutively exposed to manifold vacuum. They supply additional fuel mixture for off-idle engine requirements.

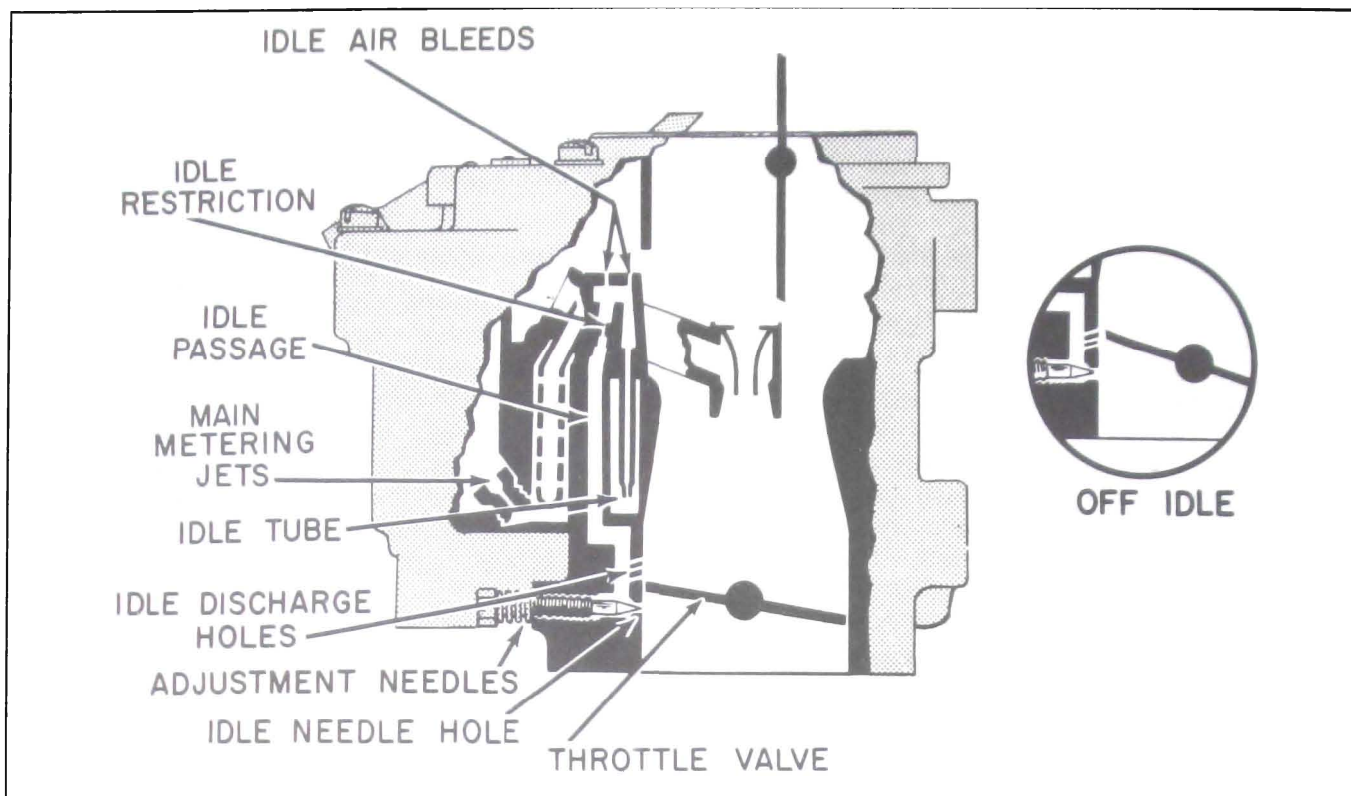

Figure 3-18—Low Speed System

d. Operation of Main Metering (High Speed) System

As the throttle valves continue to open, allowing more air to enter the manifold and engine speed increases, the pressure increases below the throttle valves and the fuel mixture supplied below the throttle valves gradually diminishes.

With the increased throttle opening, there is increased velocity in the venturi system. This causes a drop in pressure in the large venturi which is increased many times in the small venturi. Since the low pressure (high vacuum) is now in the small venturi, fuel will flow in the following manner:

Fuel from the float bowl passes through the main metering jets into the main well and rises in the main well tubes. Air entering the main well through the main well bleed and auxiliary main well bleed is mixed with fuel through calibrated holes in the main well tube. The mixture then moves up and out of the discharge nozzle into a channel where more air is added. The mixture travels down through the channel to the small venturi where it is delivered to the air stream and then to the intake manifold. See Figure 3-19.

e. Operation of Power System

To achieve the proper mixtures required when more power is desired or for extreme high speed driving, a vacuum operated power piston in the air horn and a power valve located in the bottom of the float bowl are used. Through a connecting vacuum passage from the base of the carburetor to the power piston cylinder in the air horn, the power piston is exposed to manifold vacuum at all times. See Figure 3-20.

During idle and part throttle operation, the relatively high vacuum holds the power piston up against spring tension and the power valve remains closed.

Increase in engine load lowers the manifold vacuum. When it has dropped sufficiently, the power piston spring overcomes the upward vacuum pull and the power piston moves downward, opening the power valve to allow additional fuel to flow through calibrated restrictions into the main well.

As the engine load decreases, the resulting higher vacuum overcomes the spring tension on the power piston and raises the power piston closing the power valve.

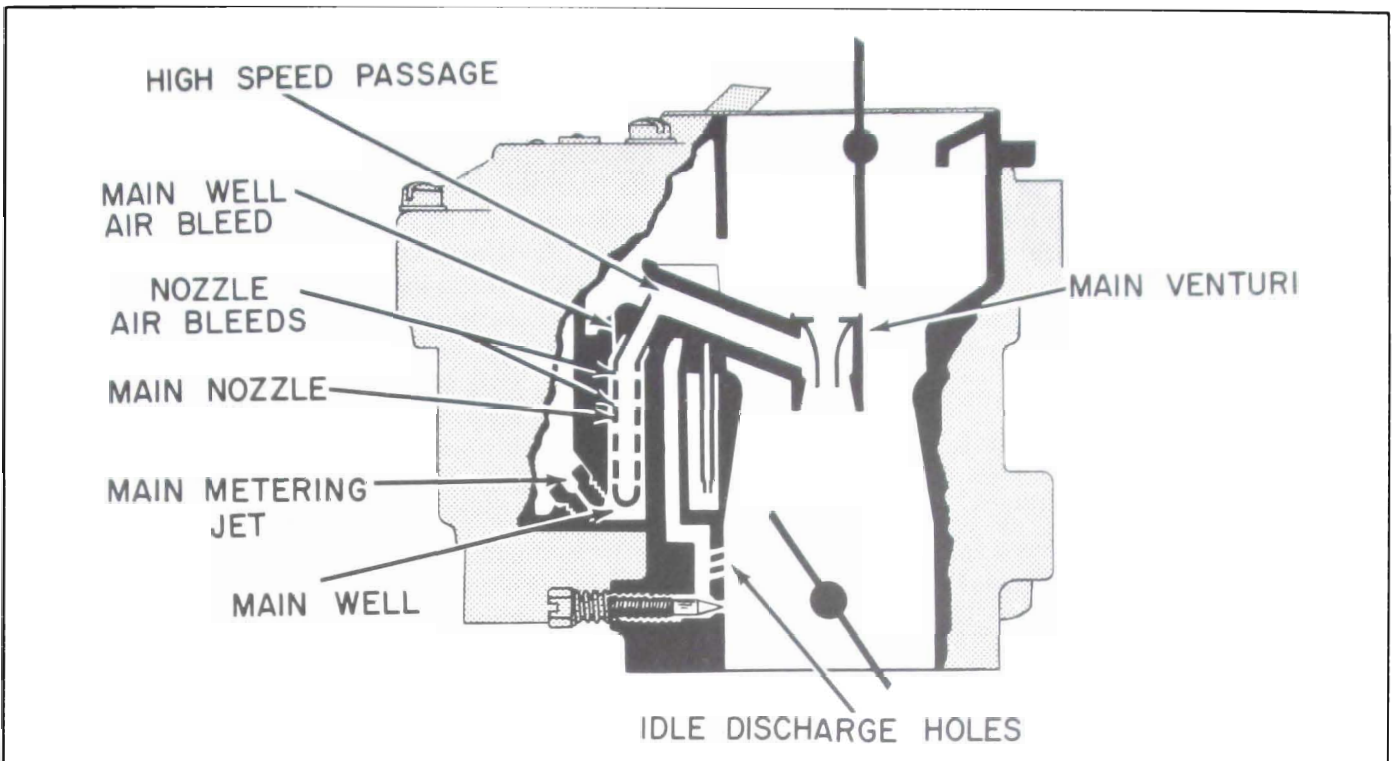

Figure 3-19—High Speed System

A 2-stage power valve is used. In the first stage, fuel is metered by the valve itself. This stage is used for light power loads. On heavy power loads the valve is fully opened to the second stage, and in this location the power valve allows the fuel to be metered by the power restrictions in the fuel channel located in the bottom of the fuel bowl.

It will be noted that the power piston cavity in the carburetor air horn is connected to the main air flow passage by a vacuum break hole. It is the purpose of this hole to prevent the transfer of vacuum acting on the piston from acting also on the top of the fuel in the float

bowl. Any leakage of air past the upper grooves of the piston will be compensated for by this vacuum break hole and will not affect carburetor metering.

f. Operation of Accelerating System

When the throttle valve is opened rapidly, the air flow and manifold vacuum change almost instantaneously, while the heavier fuel tends to lag behind causing a momentary lean-ness. The accelerator pump provides the fuel necessary for smooth operation on rapid acceleration.

Fuel for acceleration is supplied by a double-spring loaded pump plunger. The top and bottom springs combine to move the plunger so that a smooth, sustained charge of fuel is delivered for acceleration.

Fuel is drawn into the pump well through the inlet ball check on the intake stroke of the pump plunger (upward stroke). See Figure 3-21.

Downward motion of the pump plunger seats the inlet ball check and forces the fuel through the discharge passage where it unseats the pump discharge ball and then passes on through to the pump jets where it sprays into the venturii.

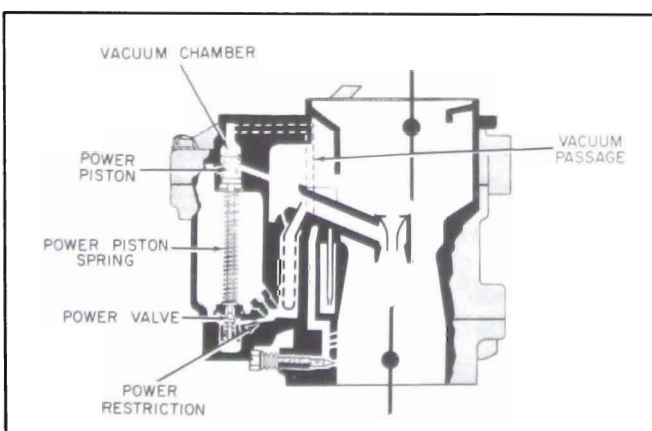

Figure 3-20—Power System

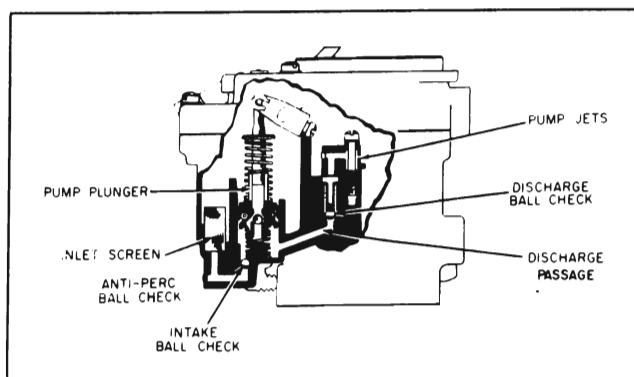

Figure 3-21—Accelerating Pump System

The ball check located in the pump plunger head serves as a vapor vent for the pump well. Without this vent, vapor pressure in the pump well might force fuel from the pump system into the engine manifold causing hard starting when the engine is hot.

The pump discharge ball check in the accelerator pump passage prevents any pullover or discharge of fuel from the pump nozzles when the accelerator pump is inoperative.

g. Operation of Choke System

The choke system is composed of a thermostatic coil, vacuum choke piston, offset choke valve, fast idle cam and choke linkage. Its operation is controlled by a combination of intake manifold vacuum, the offset choke valve, atmospheric temperature and exhaust manifold heat. See Figure 3-22.

The choke thermostatic coil is calibrated to hold the choke valve closed when the engine is cold. When the engine is started, air velocity against the offset choke valve causes the valve

to open slightly against the torque of the thermostatic coil. In addition, intake manifold vacuum applied to the choke piston through the vacuum passage tends to open the choke valve. Vacuum pull on the choke piston is offset by the tension of the thermostatic coil. As the engine warms up, heated air is drawn into the choke housing through the choke heat tube through a passage in the choke housing. As the engine temperature increases, it causes the thermostatic coil to relax its tension, which together with vacuum pull on the choke piston and air flow against the offset choke valve causes the choke valve to open gradually until the engine is thoroughly warmed up, at which point the choke valve is fully opened.

A mechanical choke unloader is incorporated to open the choke valve slightly when the engine is cold. The choke unloader provides a means for opening the choke valve to correct any loading condition encountered during cold starting.

To prevent stalling during the warm-up period, it is necessary to run the engine at a slightly higher idle speed than for a warm engine. This is accomplished by steps on the fast idle cam. The fast idle cam is in turn linked to the choke valve shaft by the choke rod, choke trip lever and choke lever and collar assembly. This holds the throttle valves open sufficiently during the warm-up period to give increased idle RPM until the choke valve moves to the fully open position and the engine is thoroughly warmed up.

3-15 DISASSEMBLY, CLEANING, AND INSPECTION OF ROCHESTER 2-BARREL CARBURETOR

a. Removal of Air Horn

1. Mount carburetor on proper holding fixture.

2. Remove clip from upper end of intermediate choke rod and disengage rod from intermediate choke shaft lever.

3. Remove pump rod by removing upper and lower retaining clips.

4. Remove trip lever screw and trip lever from end of choke shaft. Remove fast idle cam screw. Then remove choke lever, choke rod and fast idle cam as an assembly.

5. Remove inlet fitting and screen.

6. Remove air horn attaching screws and carefully remove air horn assembly from float bowl by lifting gently upward.

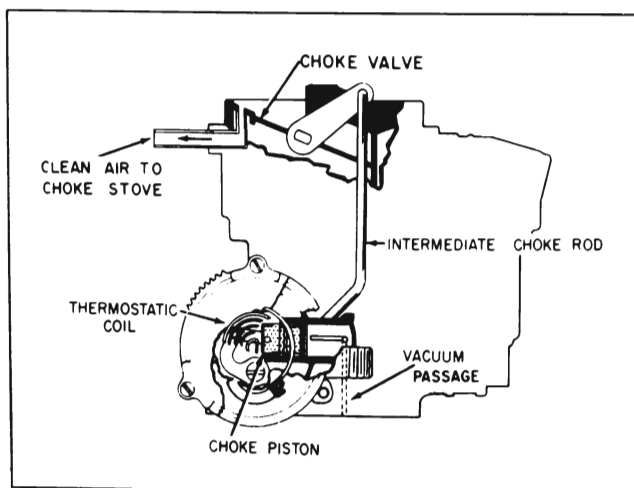

Figure 3-22—Choke System

b. Disassembly of Air Horn

1. Place air horn assembly inverted on bench. Remove float hinge pin and lift float assembly from cover. Remove float needle from float. Remove float needle seat and fibre gasket.

2. Remove power piston by depressing shaft and allowing spring to snap repeatedly, thus forcing power piston retaining washer from casting.

NOTE: If heavy staking is encountered, remove staking from around power piston retaining washer.

3. Remove retainer on end of pump plunger shaft, then remove plunger assembly from pump arm. Remove pump lever and shaft assembly by loosening set screw on inner arm and removing outer lever and shaft.

4. Remove air horn gasket.

5. Remove 2 choke valve retaining screws and remove choke valve from choke shaft. Remove choke shaft from air horn.

c. Disassembly of Float Bowl

1. Remove pump plunger return spring from pump well. Remove small aluminum check ball from bottom of pump well by inverting bowl and shaking into hand. Remove pump inlet screen from bottom of fuel bowl.

2. Remove main metering jets.

3. Remove power valve and fibre gasket.

4. Remove three venturi cluster attaching screws and remove cluster and gasket. Center cluster screw has smooth shank and fibre gasket for accelerator pump fuel by-pass.

5. Using a pair of long nose pliers, remove pump discharge ball spring T-shaped retainer. Then remove pump discharge spring and steel discharge ball.

6. Invert carburetor and remove three throttle body to bowl attaching screws. Remove throttle body and throttle body to bowl gasket.

d. Disassembly of Throttle Body

1. Remove idle mixture adjusting needles and springs.

2. Remove three retainer screws and retainers from choke cover. Remove cover, gasket and inside baffle plate.

3. Remove choke piston lever screw and take

choke piston, piston pin, connecting link and lever from thermostat housing as an assembly.

4. Remove screws holding thermostat housing to throttle body. Remove thermostat housing and gasket. Then remove intermediate choke shaft and lever assembly from thermostat housing.

5. Remove idle compensator from web between right and left venturi, if so equipped. Remove gasket. Be careful not to distort holder strip or bi-metal strip.

No further disassembly of the throttle body is needed. The throttle valves should never be removed as the idle and spark holes are drilled in direct relation to the location of the throttle valves and shaft. Removal of the throttle valves will upset this location. The throttle body assembly is only serviced as a complete unit with throttle valves intact.

e. Cleaning and Inspection

Dirt, gum, water or carbon contamination in or on the exterior moving parts of a carburetor are often responsible for unsatisfactory performance. For this reason, efficient carburetion depends upon careful cleaning and inspection while servicing.

1. Thoroughly clean carburetor castings and metal parts in carburetor cleaning solvent.

CAUTION: Gaskets or pump plunger should never be immersed in carburetor cleaner. Wash pump plunger parts in clean solvent.

2. Blow out all passages in the castings with compressed air and blow off all parts until they are dry. Make sure all jets and passages are clean. Do not use wires or drills for cleaning fuel passages or air bleeds.

3. Check all parts for wear. If wear is noted, defective parts must be replaced. Note especially the following:

(a) Check float needle and seat for wear. If wear is noted, the assembly must be replaced.

(b) Check float hinge pin for wear and float for dents or distortion. Check floats for fuel leaks by shaking.

(c) Check throttle and choke shaft bores for wear and out of round.

(d) Inspect idle mixture adjusting needles for burrs or grooves. Such a condition requires replacement.

(e) Inspect pump plunger leather, replace if damaged, worn, or hard.

(f) Inspect pump well in bowl for wear or scoring.

4. Check filter screens for dirt or lint. Clean and if they are distorted or remain plugged, replace.

5. If for any reason, parts have become loose or damaged in the cluster casting, the cluster assembly must be replaced.

6. It is recommended that new gaskets be used whenever the carburetor is disassembled or overhauled.

3-16 ASSEMBLY AND INTERNAL ADJUSTMENT OF ROCHESTER 2-BARREL CARBURETOR

a. Assembly of Throttle Body

1. Screw idle mixture adjusting needles and springs into the throttle body until finger tight. Back out screws 1-1/2 turns as a preliminary idle adjustment.

CAUTION: Do not force idle needle against its seat or damage may result.

2. Install idle compensator and gasket, if so equipped.

3. Install intermediate choke shaft and lever assembly in thermostat housing with lever downward. Install housing assembly and gasket on throttle body.

4. Install choke piston, piston pin, connecting link and lever in thermostat housing. Install screw connecting lever to intermediate choke shaft.

5. Invert float bowl assembly and place the new throttle body gasket on bowl. Install throttle body on bowl using 3 screws and lockwashers. Tighten securely.

b. Assembly of Float Bowl

1. Drop steel pump discharge check ball into discharge hole. Install pump discharge spring and T-shaped retainer, staking in place.

NOTE: Top of retainer must be flush with flat of bowl casting.

2. Install venturi cluster with gasket. Install venturi cluster screws and tighten evenly and securely. Make sure center screw is fitted

with fibre gasket and special smooth shank screw is used.

3. Install main metering jets, power valve gasket and power valve.

4. Install small aluminum inlet check ball in pump inlet in bottom of pump well; insert pump return spring and center in well by pressing downward with finger.

5. Install pump inlet screen in bottom of bowl.

c. Assembly of Air Horn

1. Install choke valve on choke shaft so that letters "RP" will face upward in finished carburetor. Install two choke valve screws but do not tighten securely until choke valve is centered.

2. Install choke lever, trip lever and retaining screw. Center choke valve on choke shaft by holding choke valve closed tightly while sliding choke shaft back-and-forth. Then with choke shaft in center of endwise travel, tighten choke valve screws and stake lightly in place. Choke should be perfectly free in all positions.

3. Install outer pump lever and shaft assembly into air horn with lever toward choke shaft. Install inner pump arm with plunger hole inward and tighten set screw.

4. Attach pump plunger assembly to inner arm with pump shaft offset pointing inward and install clip.

5. Assemble float needle seat and gasket to air horn. Tighten needle seat securely using a wide bladed screw driver.

6. Install power piston into vacuum cavity. Lightly stake piston retainer washer in place. Piston should travel freely in cavity.

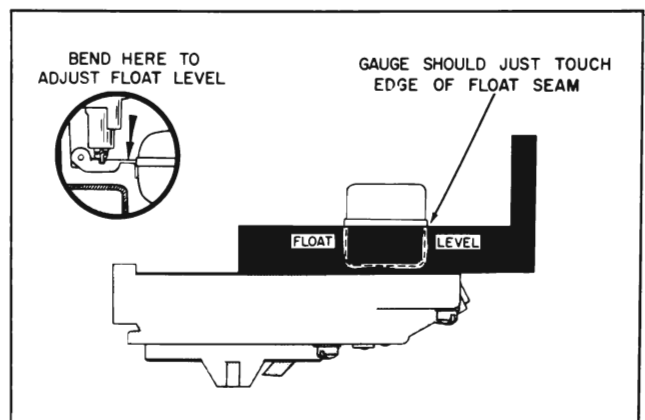

Figure 3-23—Float Level Adjustment

7. Install air horn gasket on air horn, fitting gasket over guide pin.

8. Attach needle to float. Carefully position float and insert float hinge pin.

9. **Adjust Float Level.** With air horn assembly inverted, measure distance from air horn gasket to lower edge (sharp edge) of float seam at end of float using Float Level Gauge (11/16") of Gauge Set J-9585 as shown. Bend float arm as required to adjust float level. See Figure 3-23.

10. **Adjust Float Drop.** With air horn assembly held upright, measure distance from gasket to bottom of float pontoon at outer end using Float Drop Gauge (1-29/32") as shown. Bend float tang as required to adjust float drop. See Figure 3-24.

11. Carefully place air horn assembly on float bowl, making certain that the pump plunger is positioned and will move freely. Lower cover gently straight down, then install 8 air horn to float bowl attaching screws. Tighten evenly and securely.

NOTE: Longer air horn screw goes in top of pump housing.

12. Engage choke rod in choke lever and fast idle cam. Install fast idle cam screw and tighten securely. See Figure 3-25 for proper installation.

13. Install accelerator pump rod and retainers.

14. Engage intermediate rod upper end in

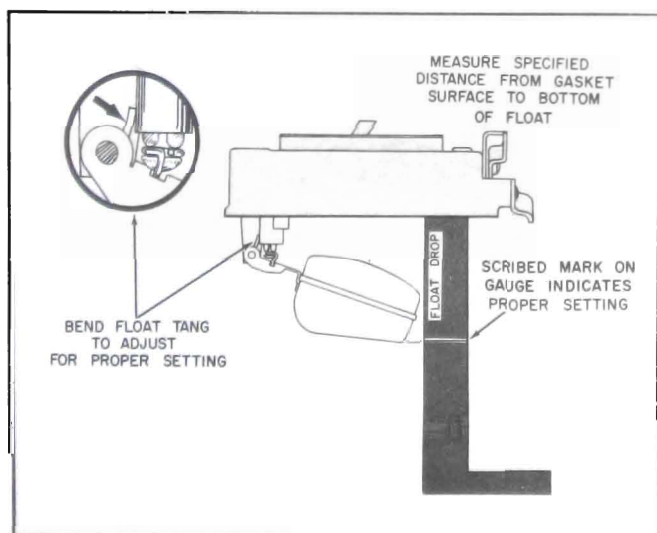

Figure 3-24—Float Drop Adjustment

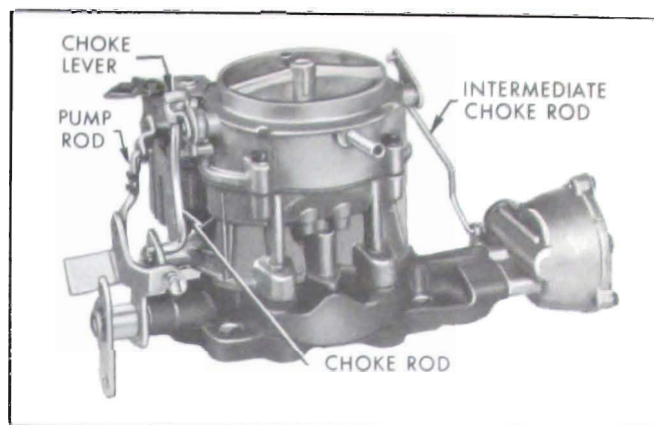

Figure 3-25—Exterior Linkage

choke shaft lever and install lower end with clip.

3-17 EXTERNAL ADJUSTMENT OF ROCHESTER 2-BARREL CARBURETOR

All adjustments on the carburetor except for the float adjustments are made externally. For float level and float drop adjustments, see steps 9 and 10 above.

a. Pump Rod Adjustment

Back out idle stop screw and completely close throttle valve in bore. Place Pump Gauge (29/32") of Gauge Set J-9585 across top of carburetor air horn on air cleaner seat (no gasket), with leg pointing downwards toward top of pump rod. Lower edge of gauge leg should just touch top of pump rod. Bend pump rod as required to obtain the proper setting using Tool J-4552. See Figure 3-26.

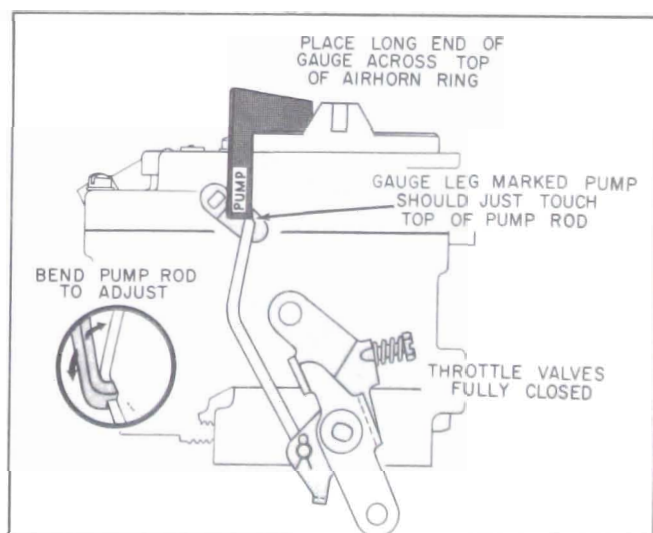

Figure 3-26—Pump Rod Adjustment

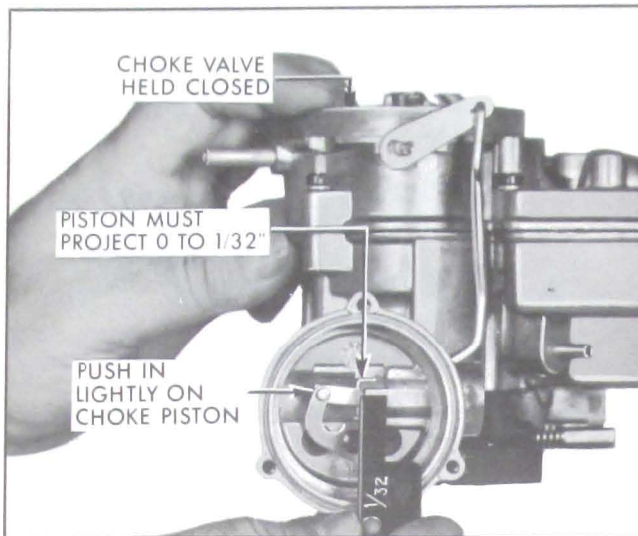

Figure 3-26A—Checking Choke Piston Adjustment

b. Choke Adjustment

Choke Piston Adjustment With choke valve held tightly closed, and with choke piston pushed lightly toward its cylinder (to take up any linkage slack), check to see that choke piston is projecting from cylinder between 0 and 1/32" using 1/32" Gauge. See Figure 3-26A. If adjustment is required, bend intermediate choke rod using Tool J-5197.

Choke Cover Adjustment. Choke mechanism must be absolutely free in any position; mechanism is free if choke will fall open from its own weight. Install choke baffle plate. Install choke cover and gasket. Rotate counter-clockwise until index marks align and choke valve is just closed, then tighten screws and retainers. See paragraph 3-8.

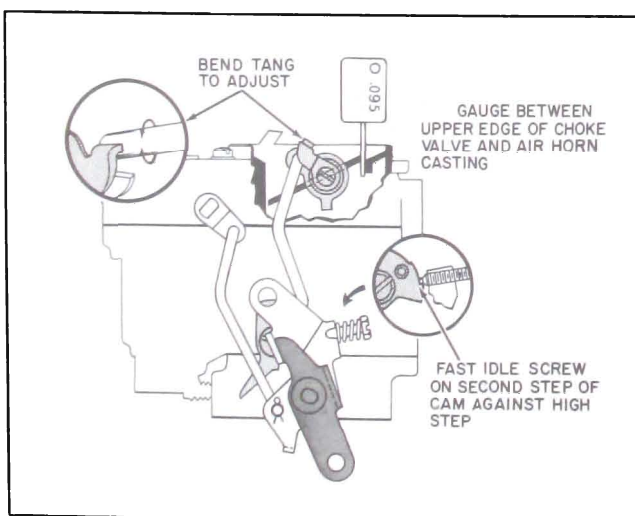

Figure 3-27—Choke Rod Adjustment

c. Choke Rod Adjustment

Turn idle stop screw into the normal idle position (normal idle position would be with the stop screw turned in approximately 1-1/2 turns against the fast idle cam with the choke valve held fully open). Place idle stop screw on second step of fast idle cam against shoulder of high step. Wire end of .095" (#41) Gauge should just go between upper edge of choke valve and wall of air horn. Bend tang on choke lever to obtain correct choke rod setting. See Figure 3-27.

d. Choke Unloader Adjustment

With throttle valves held wide open, choke valve should open just enough to admit wire end of 1/4" Gauge between upper edge of choke valve and inner air horn wall. Bend unloader tang on throttle lever to obtain proper clearance. See Figure 3-28.

e. Fast Idle Adjustment

A fast idle speed adjustment is not required because fast idle is controlled by the throttle stop screw. If the idle speed is correctly set and the choke rod properly adjusted, the proper fast idle will be maintained.

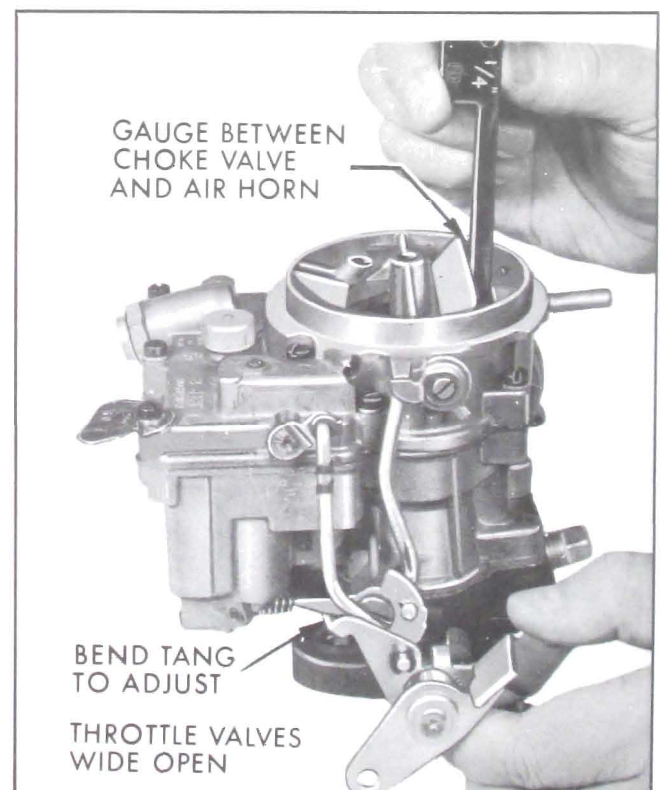

Figure 3-28—Choke Unloader Adjustment