

GROUP 6

REAR AXLE ASSEMBLY

SECTIONS IN GROUP 6

| Section | Subject | Page | Section | Subject | Page |
|---------|--|------|---------|--------------------------------|------|
| 6-A | Rear Axle Specifications, Description, Trouble Diagnosis | 6-1 | 6-C | Positive Traction Differential | 6-21 |
| 6-B | Rear Axle Service Procedures | 6-7 | 6-D | Propeller Shaft | 6-26 |

SECTION 6-A

REAR AXLE SPECIFICATIONS, DESCRIPTION, TROUBLE DIAGNOSIS

CONTENTS OF SECTION 6-A

| Paragraph | Subject | Page | Paragraph | Subject | Page |
|-----------|--------------------------|------|-----------|-----------------------------|------|
| 6-1 | Rear Axle Specifications | 6-1 | 6-3 | Rear Axle Trouble Diagnosis | 6-3 |
| 6-2 | Description of Rear Axle | 6-2 | | | |

6-1 REAR AXLE SPECIFICATIONS

a. Tightening Specifications

Use a reliable torque wrench to tighten the parts listed, to insure proper tightening with-

out straining or distorting parts. These specifications are for clean and lightly lubricated threads only; dry or dirty threads produce increased friction which prevents accurate measurement of tightness.

| Part | Location | Thread Size | Torque Ft. Lbs. |
|------------|--|-------------|-----------------|
| Bolt | Center Bearing Support to Frame | 5/16-24 | 20-30 |
| Nut | Clamp, Rear Universal Joint to Pinion Flange | 5/16-24 | 15-18 |
| Nut | Differential Carrier to Housing | 3/8-24 | 45-55 |
| Nut | Spring, Upper End to Frame | 1/2-13 | 15-20 |
| Bolt | Track Bar Cross Member Brackets to Frame | 3/8-16 | 40-50 |
| Bolt & Nut | Upper Control Arm, Inner to Outer Arm | 7/16-14 | 60-70 |
| Bolt & Nut | Rear Shock, Lower End to Axle Bracket | 7/16-14 | 35 Min. |
| Bolt | Ring Gear to Case | 7/16-20 | 65-75 |
| Nut | Wheel Bearing Retainer and Brake Assembly to Housing | 7/16-20 | 65-75 |
| Bolt & Nut | Differential Bearing Support Clamping | 1/2-20 | 40-50 |
| Nut | Spring, Lower End to Axle | 1/2-13 | 20-30 |
| Nut | Rear Shock, Upper End to Frame | 1/2-13 | 35-45 |
| Nut | Wheel and Brake Drum to Rear Axle Shaft | 1/2-20 | 65-75 |
| Bolt & Nut | Track Bar to Axle or Frame Bracket | 5/8-18 | 100-140 |
| Bolt & Nut | Control Arm Pivot, All | 5/8-18 | 100-140 |
| Nut | Pinion Bearing Lock | 7/8-14 | 200-300 |

b. General Specifications

| Items | All Series |
|--|---------------------------|
| Rear Axle Type | Semi-Floating Hypoid |
| Drive and Torque | Through 3 Control Arms |
| Rear Axle Oil Capacity | 4 1/2 pints |
| Ring and Pinion Gear Set Type | Hypoid |
| Bolted Ring Gear | 12 Bolts—7/16 Alloy |
| Pinion Position Adjustment | Shims |
| Pinion Bearing Pre-load Adjustment | Spacers |
| Ring Gear Position and Pre-load Adjustment | Shims |
| Rear Universal Joint Angle Adjustment | Vernier—Upper Control Arm |

b. General Specifications (Cont.)

| Items | All Series |
|------------------------------|--|
| Differential Cover | Welded to Housing |
| Propeller Shaft | 2 Piece—Open Drive Line |
| Center Support | Ball Bearing |
| Universal Joints | 2 Single—1 Double Constant Velocity |

c. Limits for Fitting and Adjusting

| | |
|-----------------------------------|---|
| Pinion Position | ± .0015 from Marking on Pinion |
| Pinion Bearing Pre-Load | .15-.35 Inch Lbs. Torque on Pinion with New Seal |
| Ring Gear Position | .007-.009 Backlash |
| Ring Gear Pre-Load | .004 Compression (.002 per side) |

d. Rear Axle Gear Ratios

Gear ratios are indicated by numbers stamped on the bottom of the axle housing. The production date is also indicated by a stamped number which represents the day of the year starting with "1" for January 1. See Figure 6-1.

e. Speedometer Gears

Speedometer gears must correspond to axle ratios in order to have correct speedometer and odometer readings. See Figure 6-1.

6-2 DESCRIPTION OF REAR AXLE

The rear axle assembly is of the semi-floating type in which the car weight is carried on the axle shafts through ball bearings enclosed in the outer axle housing. The rear axle is designed for use with an open drive line and coil springs. Drive from the axle housing is transmitted to the frame through one upper and two lower control arms. The lower control arms also provide seats for the coil springs; the upper control arm is adjustable in length to give the desired universal joint angle. Large rubber bushings at both ends of these control arms absorb vibration and noise. The final drive is a hypoid type ring gear and pinion with the centerline of the pinion below the centerline of the ring gear. See Figure 6-2.

The drive pinion is mounted in two tapered roller bearings which are pre-loaded by two selected spacers at assembly. See Figure 6-3. The pinion is positioned by a shim located between the head of the drive pinion and the

rear pinion bearing. The front bearing is held in place by a large washer and a locking pinion nut. The differential carrier casting has an oil feed passage to the pinion bearings and an oil return hole so that the oil will circulate and cool.

The differential is supported in the carrier by two tapered roller side bearings. These are pre-loaded by inserting shims between the bearings and the pedestals. The differential assembly is positioned for proper gear and pinion back-lash by varying these shims. The bearings are centered on the cross axis by lock taper cones secured in the pedestal bores by clamp bolts. The ring gear is bolted to the case. The case houses two side gears in mesh with two pinions mounted on a pinion axle which is anchored in the case by a spring pin. The pinions and side gears are backed by bronze thrust washers.

The axle shaft inner splines engage the differential side gears with a floating fit. The outer ends are supported in the axle housing by thrust type ball bearings which are factory packed for the life of the bearings and sealed on both sides. The axle shaft oil seals are located inboard of the bearings. The bearings are secured against a shoulder on the shaft by a press fit retaining ring. Inward movement of the bearing and shaft assembly is stopped by a shoulder in the housing; outward movement is stopped by a retainer plate. Wheel side thrust is taken at the wheel bearings, so an axle shaft may be removed by removing the nuts holding the bearing retainer and brake backing plate to the axle housing flange. See Figure 6-4.

CHART-SPEEDOMETER AND REAR AXLE GEARS

| <u>Axle Ratio</u> | <u>Ring Gear #Teeth</u> | <u>Pinion Gear #Teeth</u> | <u>Speedo Worm #Teeth</u> | <u>Speedo Driven Gear #Teeth</u> | <u>Gear Color</u> | <u>Tires</u> |
|-------------------|-------------------------|---------------------------|---------------------------|----------------------------------|-------------------|--------------|
| 2.78 | 39 | 14 | 9 | 18 | Purple | 7.60 x 15 |
| | | | | 17 | Brown | 8.00 x 15 |
| 3.07 | 43 | 14 | 9 | 19 | Blue | 7.60 x 15 |
| 3.23 | 42 | 13 | 9 | 20 | Red | 7.60 x 15 |
| | | | | | | 8.00 x 15 |
| 3.36 | 47 | 14 | 9 | 21 | Green | 7.60 x 15 |
| | | | | | | 8.00 x 15 |
| 3.58 | 43 | 12 | 8 | 20 | Red | 7.60 x 15 |
| | | | | | | 8.00 x 15 |
| 3.91 | 43 | 11 | 7 | 19 | Blue | 7.60 x 15 |
| | | | | | | 8.00 x 15 |
| 4.45 | 49 | 11 | 7 | 22 | Natural | 7.60 x 15 |
| | | | | | | 8.00 x 15 |

Figure 6-1—Chart - Speedometer and Rear Axle Gears

The rear axle filler plug is located in the right side of the carrier casting. The lubricant level is correct when the level is at the filler opening to 1/4 inch below the filler opening. Since periodic lubricant changes are not recommended, there is no drain plug. The rear brake drum is mounted against the axle shaft flange on bolts pressed through from the in-board side of the axle flange. **CAUTION: Left side wheel bolts have left hand threads.**

A seal in the front of the carrier bears against the pinion flange to prevent differential gear oil from leaking around the O.D. of the flange. An O-ring seal is compressed between the pinion flange and the drive pinion to prevent gear oil from leaking out through the splines. See Figure 6-2.

6-3 REAR AXLE TROUBLE DIAGNOSIS

a. Elimination of External Noises

When a rear axle is suspected of being noisy it is advisable to make a thorough test to determine whether the noise originates in the tires, road surface, front wheel bearings, engine, transmission, or rear axle assembly. Noise which originates in other places cannot be corrected by adjustment or replacement of parts in the rear axle assembly.

(1) Road Noise. Some road surfaces, such as brick or rough surfaced concrete, cause noise which may be mistaken for tire or rear axle noise. Driving on a different type of road, such as smooth asphalt or dirt, will quickly show whether the road surface is the cause of

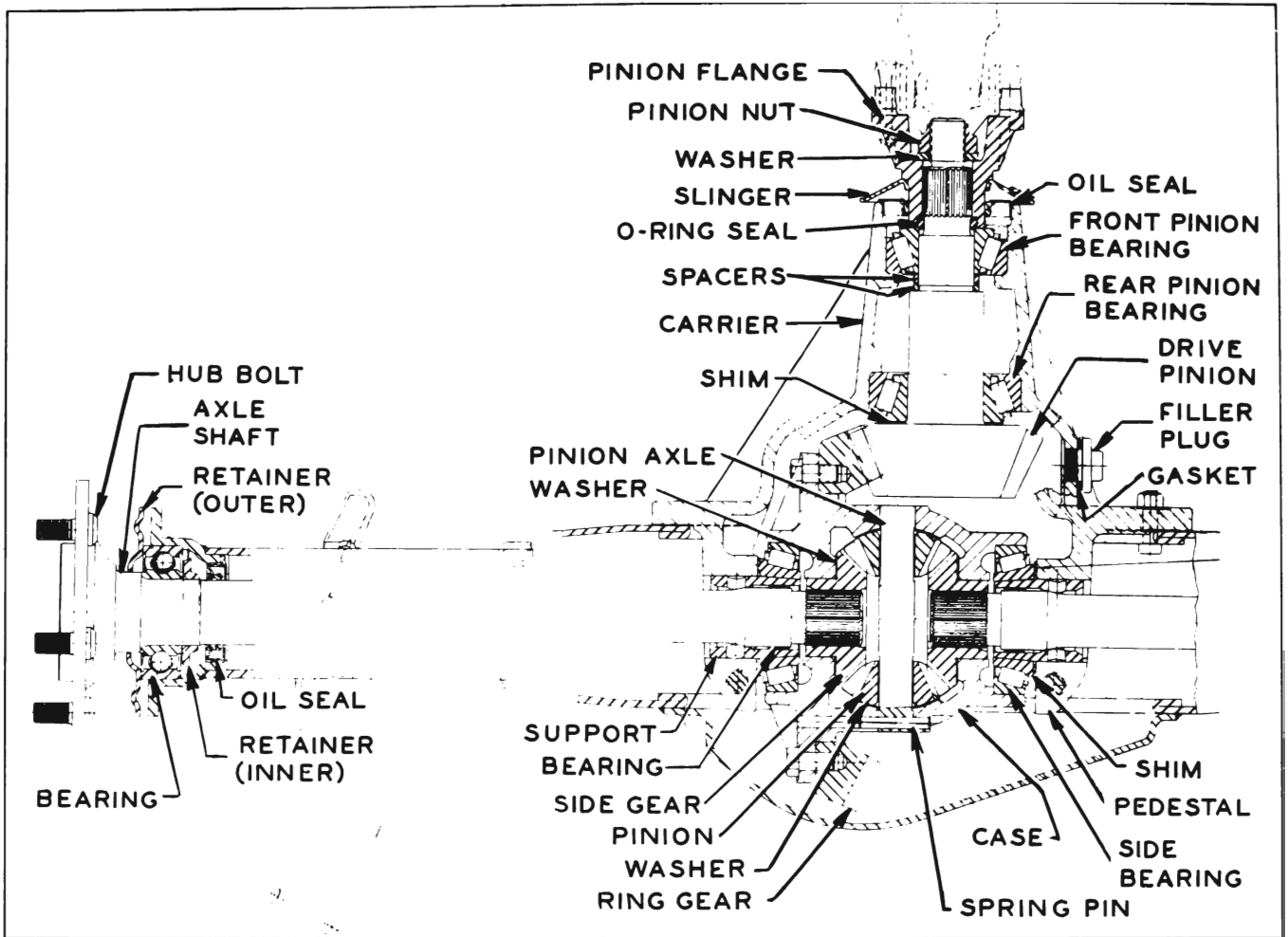

Figure 6-2—Rear Axle Assembly

noise. Road noise usually is the same on drive or coast.

(2) Tire Noise. Tire noise may easily be mistaken for rear axle noise even though the

noisy tires may be located on the front wheels. Tires worn unevenly or which have the surfaces of the non-skid divisions worn in saw-tooth fashion are usually noisy, and may produce vibrations which seem to originate elsewhere

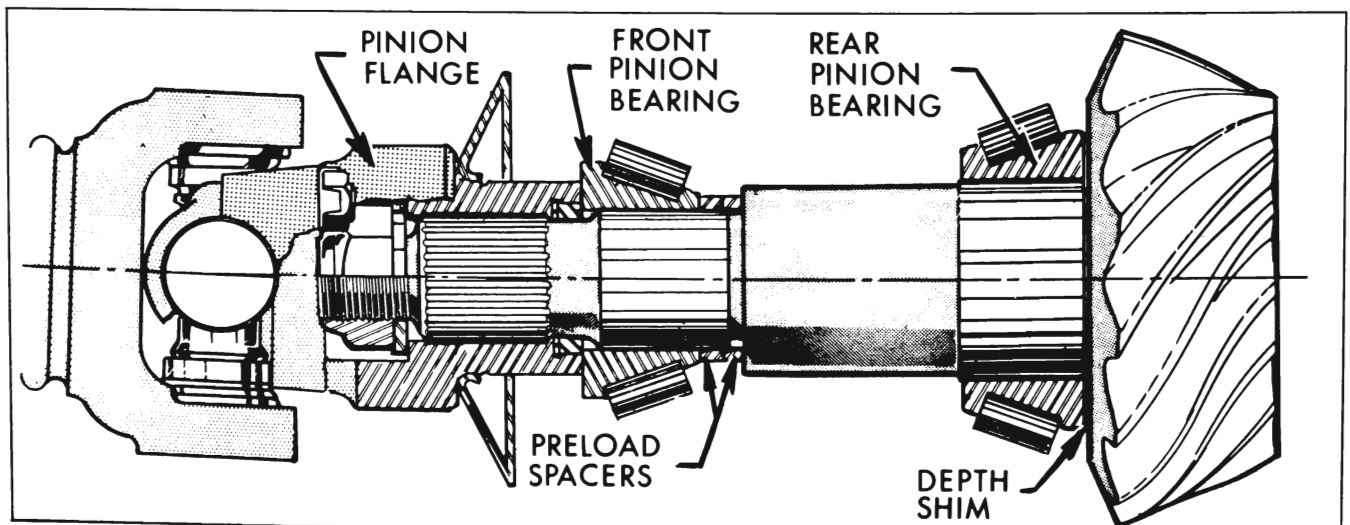

Figure 6-3—Drive Pinion Parts

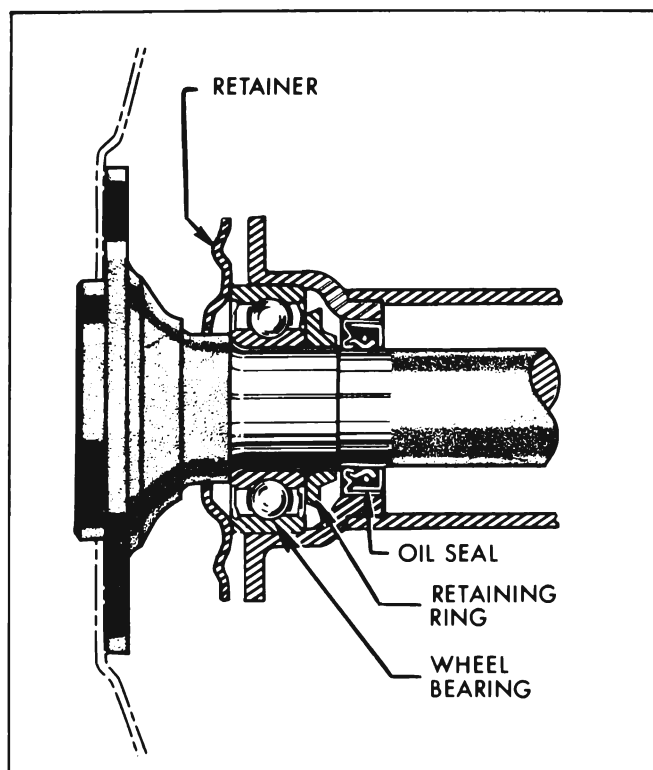

Figure 6-4—Rear Wheel Bearing and Seal

in the vehicle. This is particularly true with low tire pressure. Some designs of non-skid treads may be more noisy than others, even when tires are new.

(3) Test for Tire Noise. Tire noise changes with different road surfaces but rear axle noise does not. Temporarily inflating all tires to approximately 50 pounds pressure, for test purposes only, will materially alter noise caused by tires, but will not affect noise caused by the rear axle. Rear axle noise usually ceases when coasting at speeds under 30 miles per hour; however, tire noise continues but with lower tone as car speed is reduced. Rear axle noise usually changes when comparing drive and coast, but tire noise remains about the same.

(4) Front Wheel Bearing Noise. Loose or rough front wheel bearings will cause noise which may be confused with rear axle noises; however, front wheel bearing noise does not change when comparing drive and coast. Light application of brake while holding car speed steady will often cause wheel bearing noise to diminish as this takes some weight off the bearing. Front wheel bearings may be easily checked for noise by jacking up the wheels and spinning them, also by shaking wheels to determine if bearings are loose.

(5) Engine and Transmission Noises. Sometimes a noise which seems to originate in the rear axle is actually caused by the engine or transmission. To determine which unit is actually causing the noise, observe approximate car speeds and conditions under which the noise is most pronounced, then stop car in a quiet place to avoid interfering noises. With transmission in neutral, run engine slowly up and down through engine speeds corresponding to car speed at which the noise was most pronounced. If a similar noise is produced with car standing it is caused by the engine or transmission, and not the rear axle.

b. Rear Axle Noises

If a careful test of the car shows that the noise is not caused by external items as described in subparagraph a, it is then reasonable to assume that the noise is caused by the rear axle assembly. The rear axle should be tested on a smooth level road to avoid road noise. It is not advisable to test rear axle for noise by running with rear wheels jacked up.

Noises in the rear axle assembly may be caused by faulty propeller shaft or rear wheel bearings, faulty differential or pinion shaft bearings, misalignment between two U-joints, differential side gears and pinions worn, or by a mismatched, improperly adjusted or scored ring and pinion gear set.

(1) Rear Wheel Bearing Noise. A rough rear wheel bearing produces a vibration or growl which continues with car coasting with transmission in neutral. A brinnelled rear wheel bearing causes a knock or click approximately every two revolutions of rear wheel since the bearing rollers do not travel at the same speed as the rear axle and wheel. With rear wheels jacked up, spin rear wheels by hand while listening at hubs for evidence of rough or brinnelled wheel bearing.

(2) Differential Side Gear and Pinion Noise. Differential side gears and pinions seldom cause noise since their movement is relatively slight on straight ahead driving. Noise produced by these gears will be most pronounced on turns.

(3) Pinion Bearing Noise. Rough or brinnelled pinion bearings produce a continuous low pitch whirring or scraping noise starting at relatively low speed.

(4) Ring and Pinion Gear Noise. Noise produced by the ring and pinion gear set generally

shows up as drive noise, coast noise, or float noise.

(a) Drive noise is most evident on constant acceleration through the speed range.

(b) Coast noise is most evident when car is allowed to coast through the speed range with throttle closed.

(c) Float noise is most evident while just barely holding the car speed constant on a level road at any speed.

(d) Drive, coast, and float noises will be very rough and irregular if the differential or pinion shaft bearings are rough, worn, or loose, and will vary in tone with speed.

c. Check for Propeller Shaft Vibration

Objectionable vibrations at high speed (65 m.p.h. or higher) may be caused by a propeller shaft that is out of balance. Out of balance may be due to a bent shaft.

To determine whether the propeller shaft is causing vibration, drive car through the speed range and note car speed at which vibration is most pronounced. Shift transmission into low range and drive car at same engine speed as when vibration was most pronounced in direct drive, and note the effect on vibration.

To determine the required engine speed, divide car speed by the transmission gear ratio, using 1.8 for automatic. Example: If vibration is most pronounced at 65 m.p.h. in direct drive, the same engine speed would be

produced in low range at $\frac{65}{1.8} = 36$ m.p.h.

If the vibration is still present at the same engine speed whether in direct drive or in the lower gear, then the propeller shaft is not out of balance. If the vibration decreases or is eliminated in the lower gear then the propeller shaft is out of balance and should be removed for correction.

d. Oil Leaks

It is difficult to determine the source of some oil leaks. When there is evidence of an oil leak at these locations, the probable cause is as follows:

(1) Oil coming from the bottom edge of the brake backing plate is caused by either a leaking wheel bearing seal or a leaking brake cylinder. The feel and smell of the leaking oil will help determine the type leak to expect.

(2) Oil coming from between the rear pinion flange slinger and the carrier is caused by a leaking pinion seal. Oil coming out around the pinion nut is caused by a defective O-ring seal between the drive pinion and the pinion flange.

Even after the point of leakage has been determined, it is hard to tell whether the oil is leaking past the lip of the seal or past the OD of the seal. Therefore it is a good idea to make sure the leak is stopped by using a non-hardening sealing compound around the OD of the new seal.