

SECTION 7-C

SERVICE, ADJUSTMENT, AND REPLACEMENT PROCEDURES—CHASSIS SUSPENSION

CONTENTS OF SECTION 7-C

Paragraph	Subject	Page	Paragraph	Subject	Page
7-8	Tire Service and Inspection . . .	7-13	7-13	Checking and Replacing Chassis Springs	7-19
7-9	Replace and Adjust Stabilizer Link Grommets	7-15	7-14	Removal and Installation of Brake Reaction Rod	7-25
7-10	Replace and Adjust Front Wheel Bearings	7-16	7-15	Replace or Rebrush Lower Control Arm Assembly	7-25
7-11	Removal and Installation of Ball Joints and/or Steering Knuckle	7-16	7-16	Track Bar Service and Replacement	7-25
7-12	Removal and Installation of Upper Control Arm Shaft or Arm, and Shaft and Ball Joint Assembly	7-18	7-17	Shock Absorber Service and Replacement	7-28
			7-18	Front Wheel Alignment	7-28

7-8 TIRE SERVICE AND INSPECTION

a. Tire Inflation and Inspection

Maintenance of correct inflation pressure in all tires is one of the most important elements of tire care. Correct tire pressure is also of great importance to ease of handling and riding comfort. Overinflation is detrimental to tire life but not so much as underinflation. Inflate all tires according to tire temperature as specified in paragraph 1-3.

Driving without valve caps contributes to underinflated tires. The valve cap keeps dirt and water out of the valve core and seals the valve against leakage. Whenever tires are inflated be sure to install valve caps and tighten firmly by hand. Make sure that rubber washer in cap is not damaged or missing.

If tires are checked at frequent intervals and adjusted to correct inflation pressure, it is often possible to detect punctures and make a correction before a tire goes flat, which may severely damage tire if car is in motion. Slight differences in pressure between tires will always be found, but a tire that is found to be 3 or more pounds below the lowest of its running mates can be suspected of having a leaking valve or a puncture.

All tires should be inspected regularly to avoid abnormal deterioration from preventable causes. If tires show abnormal or uneven wear the cause should be determined and correction should be made.

See that no metal or other foreign material is embedded in the tread. Any such material should be removed to prevent damage to tread and tire carcass. Cuts in a tire which are deep enough to expose the cords will allow dirt and moisture to work into the carcass and ruin the tire unless promptly repaired.

b. Tubeless Tire Repairs

A leak in a tubeless tire may be located by inflating the tire to recommended pressure (par. 1-3) and then submerging tire and wheel assembly in water, or by applying water to tire with a hose if wheel is mounted on car. Remove water from area where air bubbles show and mark the area with crayon. After removal of the puncturing object from tire, the puncture must be sealed to prevent entrance of dirt and water which would cause damage to the tire carcass.

A small puncture of less than 3/32" diameter may be sealed without removal of tire from wheel by injecting sealing dough with a gun. Punctures up to 1/4" diameter may be sealed by installation of a rubber plug with cement, after tire has been removed from wheel. Sealing dough with gun, and rubber plugs with cement are contained in tire repair kits available through tire dealers. These materials should be used as directed in the instructions supplied with the kits. If a puncture is larger than 1/4" or there is other damage to the tire carcass, repairs should be made by authorized

tire dealers in accordance with instructions of the tire manufacturer.

c. Wheel Leaks

Examine rim flanges for sharp dents. Any dent visible to the eye should be straightened. The rim flanges should be thoroughly cleaned with No. 3 coarse steel wool thereby removing all oxidized rubber, soap solution, etc. If the flange is rusted, it can be cleaned with a wire brush or in extreme cases of pitted rims a file can be used.

In isolated cases loss of air may result from loose rivets or porous welds. If the leak is minute and the rivet is not perceptibly loose, the leak can be sealed with a cement available from tire manufacturers for this purpose. If the rivet is noticeably loose or the air leak is large replace the wheel.

CAUTION: Under no condition should loose rivets or porous welds be brazed, welded or peened.

d. Demounting and Mounting of Tubeless Tire

When demounting a tubeless tire use care to avoid damaging the rim-seal ridges on tire beads. A "bead breaker" is recommended for loosening the beads. **DO NOT USE TIRE IRONS TO FORCE BEADS AWAY FROM WHEEL RIM FLANGES.** After both beads are broken loose from wheel rim flanges, remove tire in usual manner, starting at the valve stem, and using care to avoid damaging rim-seal ridges.

When tire is removed, inspect it carefully to determine whether loss of air was caused by puncture or by improper fit of beads against rim flanges. If improper fit is indicated, check wheel as follows:

(1) Straighten wheel rim flanges if bent or dented.

(2) Clean rims thoroughly, using No. 3 coarse steel wool, to remove all oxidized rubber, soap solution, etc. Remove rust with wire brush.

(3) Inspect butt weld and other areas of rim contacted by tire beads, to make certain there is no groove or high spot. Remove any groove or high spot by filing smooth.

(4) Inspect valve stem and replace it if damaged. Make certain that valve stem is properly installed to provide an air tight joint.

Before mounting a tubeless tire on a wheel remove cardboard spacer, if tire is new. Moisten a cloth with mounting compound or solution and wipe rim-seal ridges of both beads to remove all foreign substance. Moisten base of both beads with mounting compound or soap solution to help beads snap into place when tire is inflated. Start tire over rim flange at point opposite valve stem, so that valve stem cannot prevent bead from dropping into the well as last section of bead is forced over the rim flange. Align balance mark on tire with valve stem.

Either a tire mounting machine or tire irons may be used; however, parts of tools contacting tire beads must be smooth and clean to avoid damaging rim-seal ridges. Take small bites if tire irons are used. **DO NOT USE HAMMERS.**

CAUTION: Due to the violence with which the outer tire bead seats to the rim, it is recommended that an extension gauge with a clip-on check be used for mounting inflation. This will allow the operator to remain at a safe distance.

Remove valve core to increase flow of air during inflation. Hold tire and wheel assembly in vertical position and bounce on floor at various points around circumference to snap beads out against rim flanges. If seal cannot be effected in the foregoing manner with the rush of air, apply a tourniquet of heavy sash cord around circumference to tire and tighten it with a tire iron to force beads outward.

Inflate tire until both beads are firmly seated against rim flanges, then remove air chuck, insert valve core and temporarily inflate to 50 pounds pressure. Leak test wheel and tire assembly under water, and if satisfactory reduce to recommended pressure (par. 1-3).

e. Interchanging Tires

Tires tend to wear unevenly and become unbalanced as mileage accumulates. Uneven tire wear is frequently the cause of tire noises which are attributed to rear axle gears, bearings, etc., and work is sometimes needlessly done on rear axles in an endeavor to correct the noise.

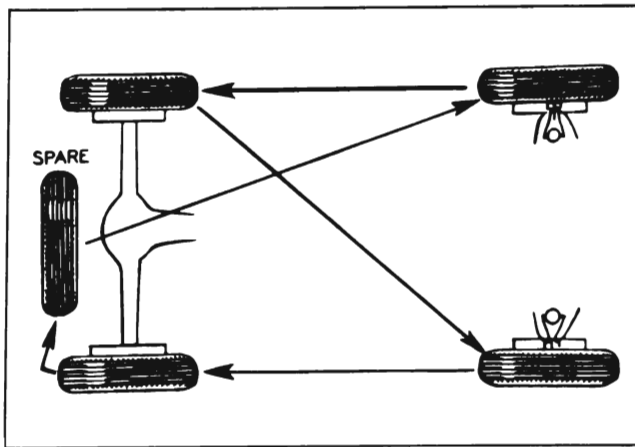

Figure 7-6—Method of Interchanging Tires

Tire life will be increased and uneven wear and noise will be less likely to occur if the tires, including the spare, are balanced and interchanged at regular intervals of approximately 5000 miles. The recommended method of interchanging tires is shown in Figure 7-6.

f. Use of Tire Chains

Do not use tire chains on the front wheels under any circumstances because they will interfere with the steering mechanism. Any of the conventional full-type non-skid tire chains can be used on the rear wheels.

Tire chains should be loose enough to "creep" but tight enough to avoid striking fenders or other parts. If chains remain in one position the tire side wall will be damaged. Tension springs (either metal coil springs or the rubber band type) must also be used in order to prevent chains contacting frame, etc. The use of tension springs will also reduce ordinary chain noise caused by loose cross links contacting pavement.

g. Wheel and Tire Balance

Wheel and tire balance is the equal distribution of the weight of the wheel and tire assembly around the axis of rotation. Wheel unbalance is the principal cause of tramp and general car shake and roughness, and contributes somewhat to steering troubles.

All wheel and tire assemblies are statically balanced to within 6 inch ounces when assembled at the factory. After installation on the car, the complete assembly may be dynamically balanced if necessary or desired.

The original balance of the tire and wheel assembly may change as the tire wears. Severe acceleration, severe brake applications, fast cornering and side slip wear the tires out in spots and often upset the original balance condition and make it desirable to rebalance the tire and wheel as an assembly. Tire and wheel assemblies should be rebalanced after punctures are repaired.

Because of the speed at which cars are driven it is important to test the wheel and tire assembly for dynamic balance. Dynamic balancing of a wheel and tire assembly must be done on a machine designed to indicate out of balance conditions while the wheel is rotating. Since procedures differ with different machines, the instructions of the equipment manufacturer must be carefully followed.

In some cases wheel and tire balance does not always overcome wheel balance complaints because the brake drums themselves are out of balance. Balancing drums with wheels and tires as an assembly is not always satisfactory because the balance is destroyed when wheels and tires are removed or interchanged. On cars where trouble is experienced in maintaining proper wheel balance, it is suggested that all drums be individually checked for static balance and corrected, if necessary, as described under Brake Drum Balance (par. 9-12).

7-9 REPLACE STABILIZER LINK GROMMETS

The construction of the stabilizer links is shown in Figure 7-7. Neoprene grommets are used at the lower ends of the stabilizer links

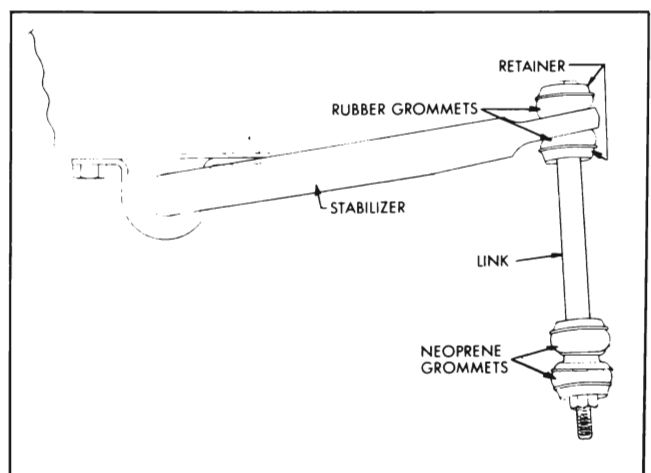

Figure 7-7—Front Stabilizer Link

for grease resistance. This offers protection from chassis lube overflow from the lower ball joints.

The upper stabilizer grommets are rubber as they are out in the open where grease resistance is not required.

To disassemble, remove nut from lower end of the link rod, then remove rod, spacer, retainers, and grommets. When new, the link grommets are 7/8" free length. When assembling, install rubber grommets dry and use care to center the grommets in the seats on stabilizer shaft and lower control arm plate, also center the retainers on grommets before tightening rod nut. Tighten rod nut to 7 ft. lbs.

7-10 REPLACE AND ADJUST FRONT WHEEL BEARINGS

a. Replacement of Bearings

1. Remove wheel with hub and drum assembly. Remove oil seal from hub so that inner bearing can be properly cleaned and inspected.

2. Wipe old grease out of hub and from steering knuckle spindle. Clean and inspect all bearing parts as described under Bearing Service (par. 1-9), and replace any that are faulty.

3. If a bearing cup outer race has to be replaced, drive the old cup out with a punch. Use care when installing the new cup to start it squarely into hub, to avoid distortion and possible cracking.

4. When inspecting or replacing bearing cones (inner races) make sure that cones are free to creep on spindle of steering knuckle. The cones are designed to creep in order to afford a constantly changing load contact between the cones and the roller bearings. Polishing the spindle and applying bearing lubricant will permit creeping and prevent rust forming between cone and spindle.

5. Wash and thoroughly dry all bearing parts, because wheel bearing lubricant will not adhere to oily surfaces.

6. Thoroughly pack both bearing assemblies with new wheel bearing lubricant, preferably using a bearing packer. If packer is not available, work lubricant into bearings by hand. In either case, remove any surplus lubricant.

7. Apply a light coating of lubricant to

spindle and inside surface of wheel hub to prevent rusting.

8. Place inner bearing assembly in cup and install a new oil seal, driving seal squarely into hub with installer J-6541. Carefully install inner bearing cone in oil seal. **NOTE:** Never place cone on spindle because seal will be damaged as wheel is installed.

9. Install wheel on spindle, then install outer bearing assembly, cone, safety washer and nut. See Figure 7-8.

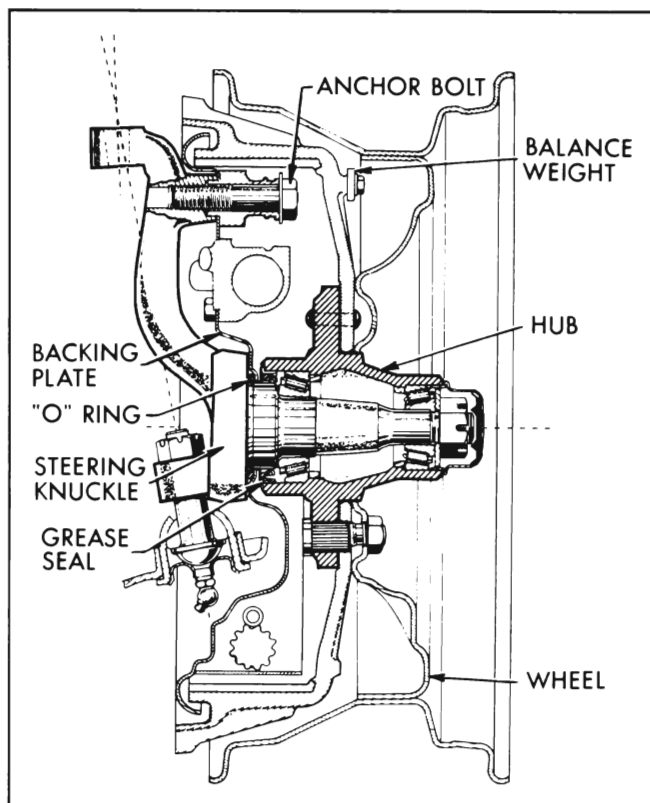

Figure 7-8—Front Wheel Hub and Bearings

10. Adjust bearings as follows (subpar. b).

b. Adjustment of Front Wheel Ball Bearings

1. Torque spindle nut to 19 ft. lbs. while rotating wheel.

2. Back off nut until bearings are loose.

3. Re-tighten nut to 11 ft. lbs. torque while rotating wheel.

4. If either cotter pin hole in spindle lines up with slot in nut, back off nut 1/12 turn and install cotter pin. 1/6 turn is maximum allowable back-up to align hole with slot.

7-11 REMOVAL AND INSTALLATION OF BALL JOINTS AND/OR STEERING KNUCKLE

a. Removal and Replacement of Upper Ball Joint

1. Raise car with jack under frame. Remove wheel and tire.

2. Remove cotterpin from castellated nut on upper ball joint tapered stud.

3. Loosen, but do not remove nut. Force of chassis spring will be tending to disengage ball joint tapered stud from steering knuckle. Rap knuckle sharply in area of tapered stud to disengage stud from knuckle. See Figure 7-15.

4. With another jack support car weight under outer edge of lower control arm and remove nut from ball joint tapered stud.

5. Now lower the jack placed under the lower control arm to slightly lower the knuckle, hub and drum assembly. Be careful to avoid damage to the brake hose.

6. Raise upper control arm and remove rubber bumper under upper control arm.

7. Ball joint may now be removed by using 1-7/8" socket, Snap-On #S-9835 or equivalent.

8. Install replacement ball joint. Seat ball joint securely against the arm. Position grease fitting towards rear of car.

9. Turn tapered stud so cotter pin hole is fore and aft and assemble rubber dust shield over stud. Move knuckle up by jacking under outer edge of lower control arm.

10. Wipe tapered hole in knuckle and tapered stud clean and assemble stud to knuckle with castellated nut. Torque to 35 ft. lbs and install cotter pin.

11. Reinstall rubber bumper.

12. Reinstall wheel and tire, and remove frame support.

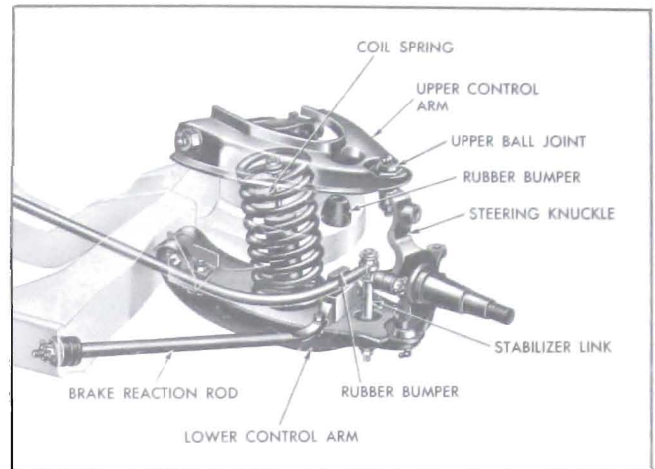

Figure 7-10—Front Suspension

b. Removal and Replacement of Lower Ball Joint

Removal

1. Raise car and support solidly under frame side rails.

2. Remove wheel and tire. Right wheels are attached with studs and nuts having right hand threads. Left wheels are attached with studs and nuts having left hand threads.

3. Remove dust cover from hub.

4. Remove backing plate and hub assembly by (a) remove cotter pin and castellated nut from end of spindle, (b) two backing plate attaching bolts and nuts and, (c) anchor bolt. There is no need to disconnect the brake hose from the wheel cylinder if the backing plate and hub assembly with hose attached is carefully wired up out of the way. See Figure 7-12.

5. For safety's sake place a floor jack under the lower control arm as far outboard on the arm as possible to gain maximum leverage advantage. Do not place the jack against the arm but about 1/2" below. Now remove cotter pin and loosen (do not remove) nut on lower ball joint tapered stud. Nut should be loosened not more than 1/8".

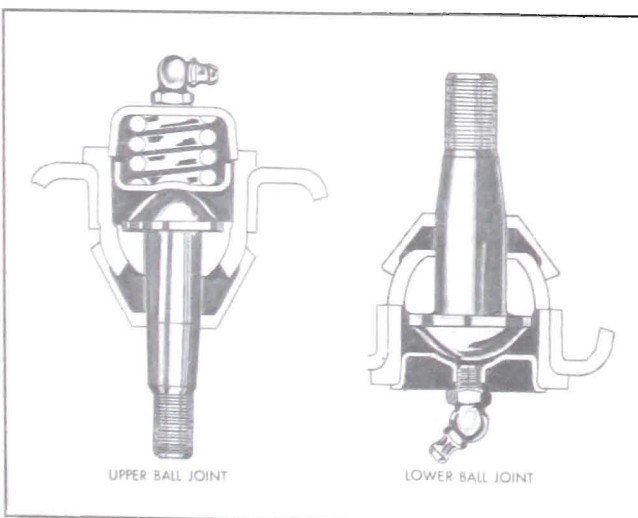

Figure 7-9—Upper and Lower Ball Joints

6. Rap steering knuckle in area of stud to separate stud from knuckle. Raise jack against control arm, remove nut and raise steering knuckle off tapered stud.

7. Remove ball joint from lower control arm. Snap-on socket S-9836 or 2-1/8" equivalent may be used.

Installation

1. Carefully install new ball joint into lower control arm. Seat ball joint securely against lower control arm. Point the 45 degree grease fitting towards the centerline of the car. Install grease shield.

2. Install knuckle over ball joint stud. Rap with hammer to seat stud in knuckle.

3. Install nut and tighten, torque is 70 ft. lbs. Install new cotter key and spread ends.

4. Jack can now be removed.

5. Making certain that new oil seal ring is installed over the knuckle spindle to seal brake backing plate install backing plate and hub assembly. The torque for the rear bolt and nut is 70 ft. lbs. and for the front bolt and nut is 45 ft. lbs. The anchor bolt torque is 140 ft. lbs.

6. Wipe dirt off spindle and lightly lube with wheel bearing lubricant. Install hub and drum assembly. Install outer roller bearing and special washer.

7. Install spindle castellated nut.

a. Torque spindle nut to 19 ft. lbs. while rotating wheel.

b. Back off nut until bearings are loose.

c. Retighten nut to 11 ft. lbs. torque while rotating wheel.

d. Back off nut at least one twelfth turn but not more than 1/6 turn, and install cotter key. Bend ends of cotter key so they do not interfere with static collector in dust cap.

8. Install wheel and tire assembly.

c. Removal and Replacement of Steering Knuckle

1. Follow steps 1 thru 5 of subparagraph b., Removal of the Lower Ball Joint. Be certain to merely loosen the nut.

2. Remove cotter pin and loosen (Do Not Remove) nut on upper ball joint tapered stud. Nut should be loosened not more than 1/8".

3. Rap steering knuckle in area of stud on both upper and lower ball joints to separate studs from knuckle. Nuts that were previously loosened still hold upper and lower control arms to knuckle.

4. Making certain that the lower control arm is adequately supported by a jack on its outer extremities to prevent any downward travel of the lower control arm when removing ball joint nut, (it may be necessary to actually raise the lower control arm slightly to remove force of the knuckle against the nut) remove the nut and raise knuckle off tapered stud.

5. The upper ball joint is already loosened from the knuckle, and with no spring force to interfere, it is now possible to remove the nut from the tapered stud and thus remove the knuckle.

6. To replace knuckle, wipe stud of upper ball joint clean, assemble to knuckle with cotter pin hole fore and aft, seat with sharp blow of hammer, torque nut to 35 ft. lbs. and install cotter pin.

7. Wipe lower ball joint stud clean and assemble to knuckle as outlined in steps 10 thru 12 subparagraph b, above.

7-12 REMOVAL AND INSTALLATION OF UPPER CONTROL ARM SHAFT OR ARM, SHAFT AND BALL JOINT ASSEMBLY

NOTE: Upper control arm shafts, bushings and ball joints are available separately. However, upper control arms are available only as an assembly (arm, shaft, bushings and ball joint).

1. Separate upper ball joint from knuckle according to steps 1 through 5 of paragraph 7-11, subparagraph a.

2. Remove shaft to frame bracket nuts, carefully noting number, location and thickness of adjusting shims between shaft and frame bracket. Remove arm assembly.

NOTE: If work is being performed on right side it is advisable to remove generator.

3. If shafts and bushings only are being replaced, clamp arm assembly in vise and remove old bushings and shaft.

4. Assemble new grease seals on shaft and position shaft in arm. Start new bushing in

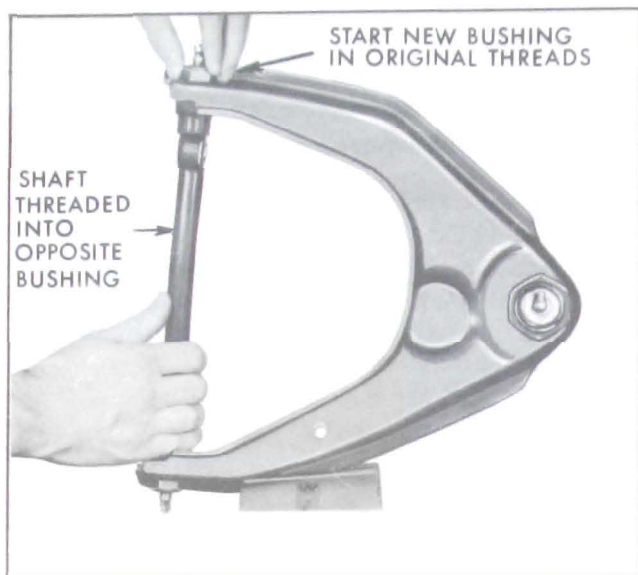

Figure 7-11—Upper Control Arm Bushing Replacement

original threads of arm and thread shaft into bushing to aid in alignment. Torque bushing to 70 ft. lbs. minimum torque.

5. Start second bushing into original threads of arm with shaft threaded into opposite bushing. See Figure 7-11.

6. After bushing has been threaded part way into arm, rotate shaft to engage threads

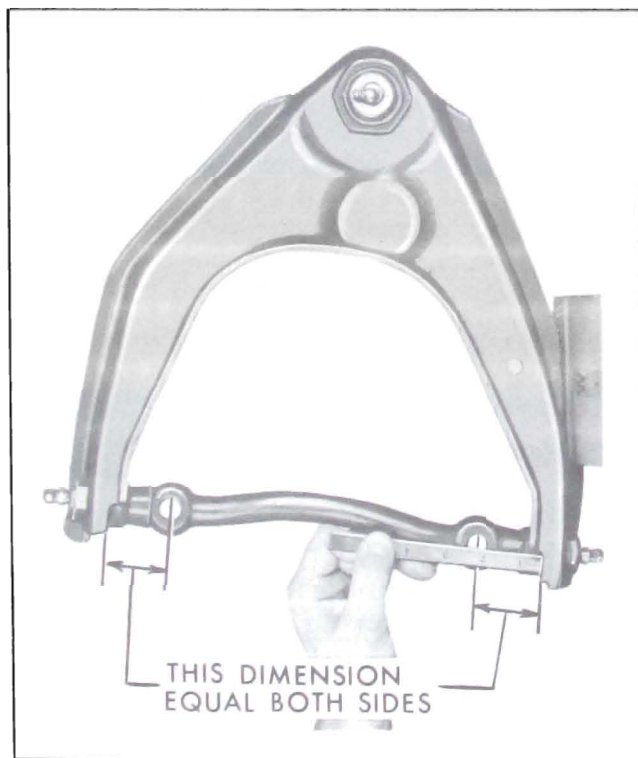

Figure 7-12—Upper Control Arm Shaft Position

of second bushing as an aid in piloting the bushing squarely into position.

7. Torque bushing to 70 minimum ft. lbs. Shaft should be free enough to turn by hand. Install grease fittings and lubricate bushings.

8. Rotate shaft to make distance between shaft bolt holes and arm equal both sides as nearly as possible. See Figure 7-12.

9. Install arm assembly by reversing removal procedure, being careful to locate the steel washers under the heads of the shaft to frame bracket bolts. Pay particular attention to number, location and thickness of adjusting shims between shaft and frame bracket. Torque shaft to frame bracket bolts to 100 ft. lbs.

10. When reassembling upper ball joint to knuckle, follow instructions outlined in paragraph 7-11, subparagraph a, steps 10, 11, 12.

11. Check and adjust front end alignment as necessary.

7-13 CHASSIS SPRINGS

a. Checking Spring Trim Dimensions

Optional equipment, undercoating, accumulated dirt, etc., changes the car weight and must be considered when checking spring trim dimensions. Because of the many possible variations in loading due to optional equipment it is not possible to give dimensions for all; therefore, the spring trim dimensions given below are for the standard car only, without optional equipment or undercoating and with car at curb weight. Curb weight includes gas, oil, water, and spare tire but no passengers.

Before measuring spring trim dimensions, bounce both ends of car up and down several times to make sure there is no bind in suspension members, and to let springs take a natural position. When car is at rest, measure the trim height at point "Y" for front spring or point "Z" for rear spring, as indicated in Figure 7-13.

(1) Front Springs. On a car having service miles the front spring trim-dimension "Y" should be as shown in Figure 7-13 chart.

NOTE: When checking NEW car add 1/4".

When the front spring trim dimension is found to be too low, correction may be made by installing special shims (Group 7.425), 1/8" thick, between upper end of spring and the frame. If more than two shims are required, replace the spring.

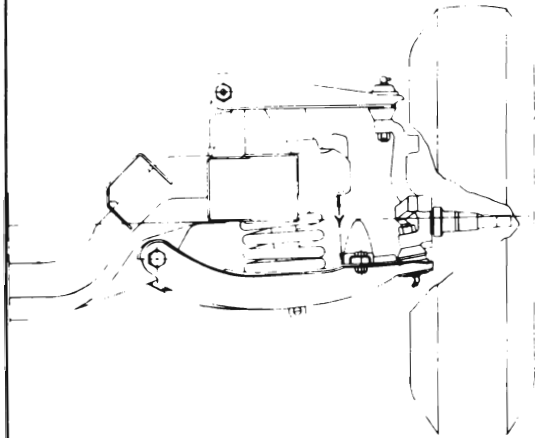

FRONT COIL SPRING

CHASSIS TRIM DIMENSION 1962						
MODEL	FRONT COIL Y: .24			REAR COIL Z: .38		
	CURB WEIGHT	NORMAL LOAD	NO. PASS.	CURB WEIGHT	NORMAL LOAD	NO. PASS.
*ALL	5.40	4.52	4	7.75	5.85	4

*NOTE: THE ABOVE IS WITH EXCEPTION OF MODELS 4635 AND 4645 WHICH HAVE REAR TRIM DIMENSIONS OF 7.00 AT CURB WEIGHT.

THESE DIMENSIONS DO NOT APPLY TO OPTIONAL SPRINGS.

ALL TRIM-HEIGHT DIMENSION SHOWN ARE FOR JOBS WITH SERVICE MILES AND WITHOUT EXCESSIVE WEIGHT.

WHEN CHECKING CURB HEIGHT FOR NEW COIL SPRINGS, ADD .24 TO FRONT "Y" DIMENSIONS AND .38 TO REAR "Z" DIMENSIONS ALLOWING LIMITS AS SPECIFIED.

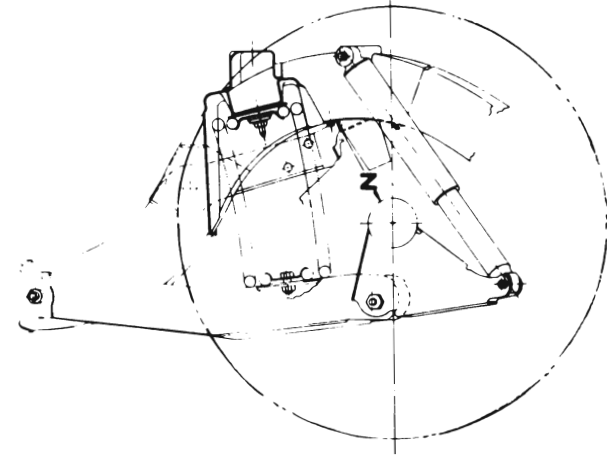

REAR COIL SPRING

Figure 7-13—1962 Chassis Trim Dimensions

(2) Rear Springs. On a car having service miles the rear spring trim dimension should be as shown on Figure 7-13 chart.

NOTE: When checking NEW car add 3/8".

If rear spring trim dimension is less than specified or additional height is required to prevent excessive "bottoming" in exceptional cases, install additional spring insulators (Group 7.545), divided between upper and lower ends of spring. If more than three additional insulators are required replace the spring. Installation of new springs should not increase trim dimension "A" more than 1" over specified maximum limit.

b. Front Coil Spring Removal and Installation

Removal

1. Raise front of car and support solidly with a car stand under the frame side rail on the side where the spring removal is to be performed. Car must be high enough to allow the lower control arm to be positioned nearly straight down with a jack placed beneath the ball stud end.

2. Remove wheel, brake drum and bearings. Take precautions against bearing damage from dirt, etc.

3. Remove the two bolts and nuts, and the anchor bolt holding the brake backing plate to the knuckle. Remove the backing plate but do not disconnect the brake hose. Support the backing plate in such a manner that the hose will not be damaged. Backing plate may be wired out of the way. See Figure 7-14.

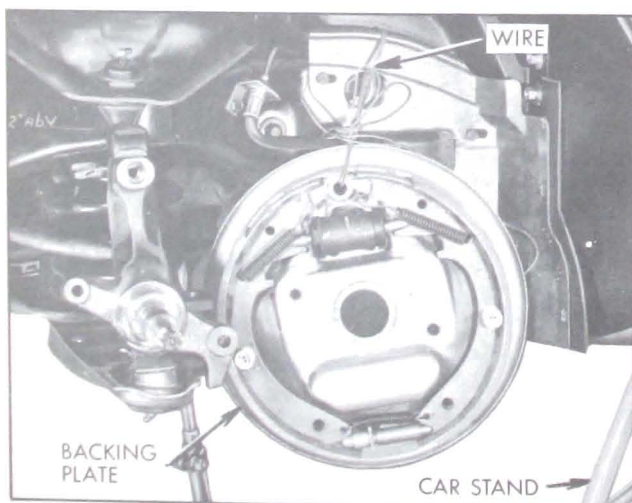

Figure 7-14—Wiring Brake Backing Plate Out of the Way

4. Remove the shock absorber. See paragraph 7-17.

5. Remove the front stabilizer rod link from the lower control arm. Place parts aside in their relative assembled position since the upper grommets are rubber while the lower ones are neoprene. They should be reassembled in this manner.

6. Disconnect the brake reaction rod and adjacent control arm bumper from the lower control arm but leave attached to the front frame cross member.

7. As a safety precaution place a floor jack under the lower control arm as far outboard on the arm as possible to gain maximum leverage advantage. It would be advantageous to remove the lube fitting at the lower ball joint so that it will not be damaged by the jack.

Do not place the jack against the arm, but about 1/2 inch below. Now remove the cotter pin and LOOSEN, DO NOT REMOVE the nut on the lower ball joint tapered stud. The nut should be loosened not more than 1/8".

8. Rap the steering knuckle in the area of the stud to separate the stud from the knuckle. See Figure 7-15. Raise the jack against the control arm to relieve pressure on the nut, remove the nut and separate the steering knuckle from the tapered stud.

9. Carefully lower the jack supporting the lower control arm to release the spring. With the jack all the way down to the floor it still may be necessary to pry the spring off its seat on the lower control arm with a long pry bar. See Figure 7-16. Caution should be exercised in handling this loaded spring while still attached.

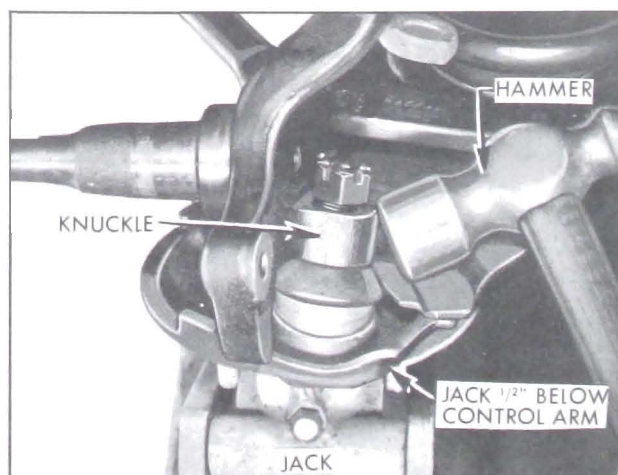

Figure 7-15—Separating Ball Stud From Knuckle

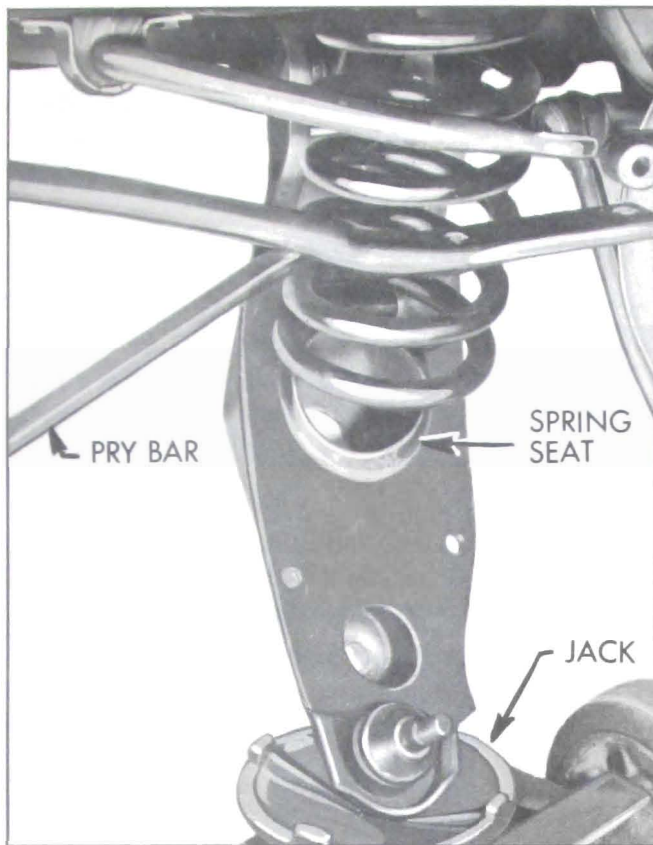

Figure 7-16—Prying Spring Off Its Seat

Installation

1. Position spring in frame upper spring seat. Align the lower end of the coil with the small hole in the lower control arm. When assembled the end of the lower coil must be within 1/4" of this hole.

2. Place plate J-7592-7 of spring installing tool J-9552 between the 4th and 5th coil of the spring from the bottom. Step in plate will fit contour of the coil. Install bolt to plate and place threaded end of the bolt through the shock absorber hole in the frame spring seat.

3. Install special nut J-9552-2 on the upper end of the bolt so that the shoulder of the nut protrudes through the hole in the upper spring seat to protect the threads of the bolt at this point.

4. Place a box wrench on the upper nut of the tool to keep it from turning. Now tighten the bolt with a 7/8" socket and extension. See Figure 7-18.

5. Tighten the bolt, compressing the spring, until at least 1-3/4" to 2" of the rod protrudes through the upper nut of the tool. At this point the spring is usually compressed sufficiently.



Figure 7-17—Tool J-9552

6. Force the spring on its seat in the lower control arm as shown in Figure 7-19. Remove tool.

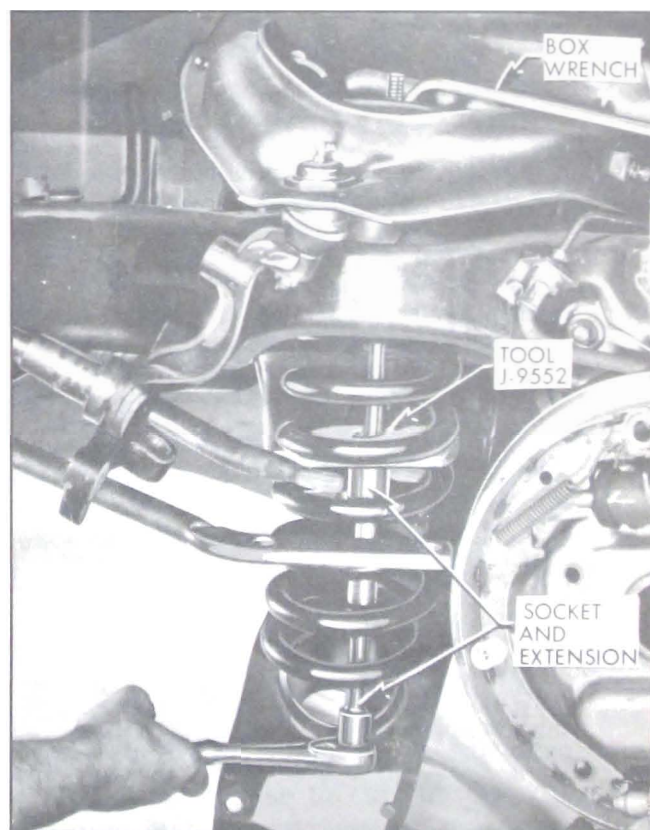

Figure 7-18—Compressing Front Spring With Tool J-9552

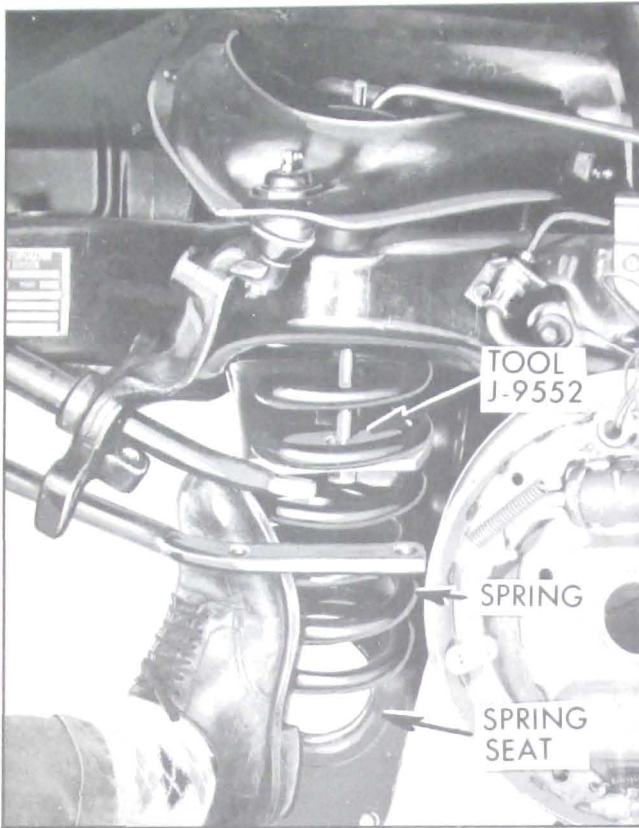

Figure 7-19—Pushing Spring on Lower Control Arm Seat

7. With the spring in position raise the lower control arm with the jack and attach the lower ball joint tapered stud to the knuckle. Make certain that the rubber dust cover is in place on the ball joint. Torque the nut to 70 ft. lbs. and install the cotter pin.

8. Install shock absorber. Torque upper nut to 10 ft. lbs., and lower bolts to 20 ft. lbs.

9. Attach brake reaction rod and compression bumper to the lower control arm. Torque the nuts to 90 ft. lbs.

NOTE: • Never use standard bolts, nuts or washers at this location. If replacement parts are needed package, Group 6.171, Part 1389760, contains the two special bolts, two special nuts and four special washers necessary for this installation.

10. Reinstall stabilizer link and grommets. Assemble in same relative position as maintained after removal so that rubber grommets are on the stabilizer end while the neoprene grommets are at the lower control arm end of the link. See Figure 7-7.

11. Reinstall backing plate to knuckle making certain that O-ring is in place on the spindle. Tighten front steering arm bolt nut to 45 ft. lbs.,

rear bolt nut to 70 ft. lbs. and anchor bolt to 140 ft. lbs.

12. Wipe any accumulated dirt off the spindle and lightly lube with wheel bearing lubricant. Install hub and drum assembly. Install outer roller bearing and special washer.

13. Install spindle castellated nut.

a. Torque spindle nut to 19 ft. lbs. while rotating wheel.

b. Back off nut until bearings are loose.

c. Retighten nut to 11 ft. lbs. torque while rotating wheel.

d. Back off nut at least 1/12 turn but not more than 1/6 turn, and install cotter pin. Bend ends of cotter pin so they do not interfere with the static collector in the dust cap.

14. Reinstall the lower ball joint grease fitting. Remove the car stand and recheck and adjust toe-in as necessary.

c. Rear Coil Spring Removal and Installation

Removal

1. Raise rear end of car and support on frame stands.

2. Mark universal joint and pinion companion flange for correct reinstallation. This maintains the balance between these two parts as installed during original assembly. Disconnect by removing U-bolt clamps at pinion flange.

3. Slide propeller shaft forward on slip spline far enough to clear rear companion flange. Wire or otherwise suitably support propeller shaft up out of the way to prevent damage to constant velocity universal joint center ball by allowing it to bend to the end of its travel.

4. Remove bolt attaching brake line bracket to rear suspension crossmember to provide slack in brake line.

5. Position jack under control arm below axle housing and raise jack slightly to relieve tension on shock absorber.

6. Disconnect shock absorber at axle bracket by removing nut and bolt.

7. Remove nut from lower spring clamp bolt and carefully lower jack to fully extend

spring and remove bolt and spring clamp from lower control arm. Upper spring clamp can now be removed.

CAUTION: Do not completely lower jack as this will cause strain on brake hose.

Installation

1. Assemble upper insulators on stud between frame and top of spring. Position top of spring up against insulator and assemble spring clamp, clamp insulator, flat washer, lock washer and nut on stud. Do not tighten at this time.

2. Place a short piece of 2 x 4 between lower end of spring and axle housing. See Figure 7-20. This assembly aid holds the spring forward on the lower control arm to facilitate attachment of the spring to the lower control arm.

3. Raise control arm to contact spring and slip spring seat between spring and control arm.

4. Insert a long tapered punch through the control arm bolt hole from the bottom to maintain alignment of the control arm and spring seat hole.

5. Slip spring clamp over punch and position straight side of clamp along straight end of spring.

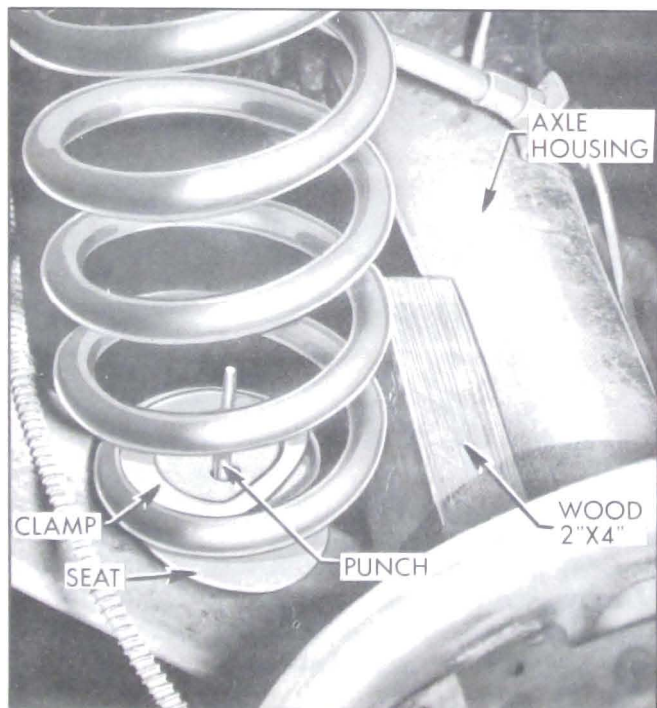

Figure 7-20—Wood Block Behind Rear Spring

6. Rotate spring if necessary to locate spring end at top as follows:

Left - top spring end towards rear of car

Right - top spring end towards front of car

Tighten upper spring clamp nut to 18 ft. lbs.

7. Raise control arm until lower spring clamp bolt can be installed. Torque lower spring clamp nut to 25 ft. lbs.

Install lower control arm to bracket on rear axle, install bolt, washer and nut and torque nut to 120 ft. lbs.

8. Re-attach shock absorber to axle bracket and remove short piece of 2 x 4 behind spring. Torque lower shock attaching nut to a minimum of 35 ft. lbs.

9. Carefully attach the propeller shaft to the rear companion flange observing the following precautions.

a. Compress the bearing cups using a 4" C-clamp to assure that the snap rings do not gouge the companion flange when seating.

b. Do not use the U-bolts to draw the bearing cups into place. U-bolts should be seated and the nuts drawn up evenly.

Use torque wrench adapter J-9113 to torque U-bolt nuts to 13 ft. lbs.

10. Reinstall brake line bracket to rear suspension cross member bolt.

11. Remove car stands and lower car.

d. Use of Special Overload Rear Coil Springs

Special 200 or 500 pound overload rear coil springs are available for service installation in cases where heavy loads are carried or heavy trailers are towed. Overloading any series rear axle in excess of 500 pounds is not recommended.

In estimating rear spring overloads, place rear wheels of car on scale, with car at curb weight and no load in rear compartment other than spare wheel and tire. After obtaining weight, hook trailer to car, or place desired load in rear compartment, and read scale again. The additional weight is the amount of overload on springs and rear axle.

Trailer design, and distance that trailer coupling is located to rear of rear axle center line, are the major factors governing effective trailer overload. Instructions for attaching trailers to Buick cars may be obtained from Buick Motor Division Factory Service Department.

7-14 REMOVAL AND INSTALLATION OF BRAKE REACTION ROD

Removal

1. Raise front of car.
2. Remove the cotter pin in the brake reaction rod, then remove the castellated nut and washer.
3. Remove the control arm to frame compression bumper by removing two bolts in the compression bumper, then remove the brake reaction rod by sliding it out of its rubber bushing on the frame front cross member.

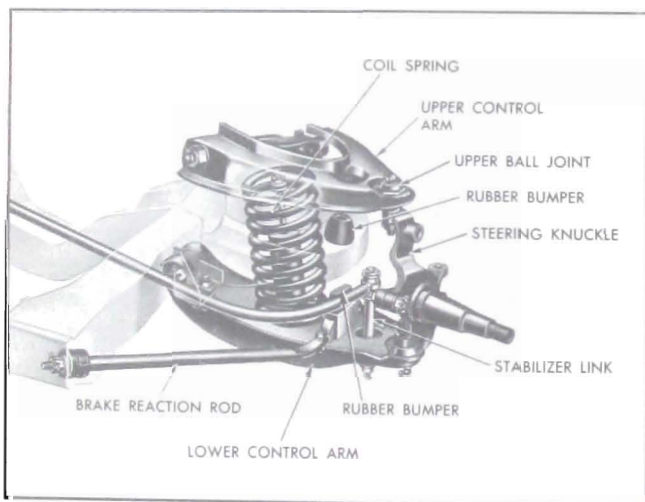

Figure 7-21—Front Suspension

Installation

1. Remove and replace old rubber bushing if worn.
2. Install washer with larger diameter on brake reaction rod first, with concave side away from nut. Install rod thru bushing in frame bracket. Install washer with smaller diameter and castellated nut. Do not tighten.
3. Install frame compression bumper over brake reaction rod and install two bolts and washers. Torque to 90 ft. lbs.; this is very important as the brake reaction rod is an integral part of the lower control arm assem-

bly and any looseness can cause detrimental car handling characteristics.

4. Torque castellated nut on brake reaction rod to 70 ft. lbs. Install cotter pin in hole of brake reaction rod.

NOTE: CASTER AND CAMBER MUST BE CHECKED AFTER REPLACEMENT OF BRAKE REACTION ROD.

NOTE: If there is any question concerning the serviceability of the brake reaction rod to lower control arm bolts, nuts or washers, install Group 6.171, Part #1389760 Package, which includes two special bolts, two special nuts and four special washers. Never use standard bolts, nuts or washers at this location.

7-15 REPLACE OR REBUSH FRONT LOWER CONTROL ARM ASSEMBLY

If a lower control arm is bent or broken it should be replaced. Consult the Buick Parts Book for the parts or assemblies required. Proceed as follows:

Removal

1. Follow steps 1 thru 9 on front coil spring removal, Section 7-13, subparagraph b.
2. Remove cotter pin from bolt of lower control arm. Now remove castellated nut and bolt. Remove lower control arm.

3. If lower control arm bushing is to be removed it may be pushed or driven from the frame using a suitable tool.

Installation

1. New lower control arm bushing should be driven into hole in frame until it bottoms against frame.

2. Slip lower control arm over bushing and install bolt and castellated nut. Torque nut to 80-120 ft. lbs. and install cotter pin. Do not back off nut to align hole in bolt for cotter pin installation. Bend tabs of cotter pin.

3. Follow Steps 1 thru 14 on replacement of front coil springs, Section 7-13, subparagraph b.

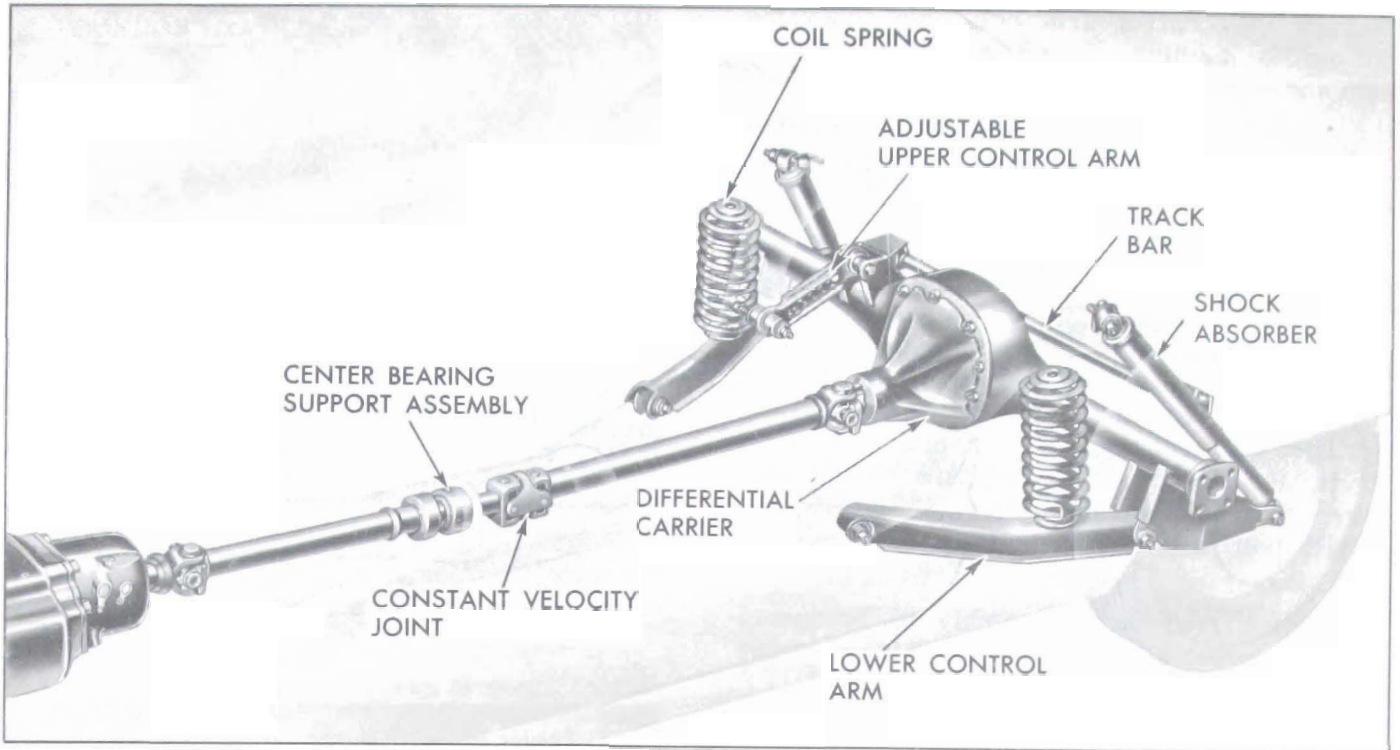

Figure 7-22—Rear Suspension

7-16 REAR SUSPENSION SERVICE PROCEDURES

a. Removal and Installation of Lower Control Arm

Removal

1. Follow Steps 1 thru 7 for removal of the rear springs, Section 7-13, subparagraph c. Spring need only be disconnected at the lower seat.

2. With the bottom of the spring positioned off of the control arm and towards the differential carrier, raise rear axle assembly to permit reconnecting shock absorber to lower bracket. This is done to help maintain position of rear axle assembly so as to reduce binding of lower control arm and thus facilitate removal.

3. With housing still supported, remove lower control arm rear bracket bolt. If some difficulty is encountered in removing bolt, reposition jack farther forward under nose of carrier and slowly raise to relieve pressure and bind at control arm bushing. It may be necessary to use suitable brass drift to tap out bolt.

4. Remove lower control arm front bracket

nut and bolt. After nut is removed it may be necessary to tap out bolt with brass drift. Remove lower control arm.

Installation

1. Before installing control arm, check front edges of control arm brackets and remove burrs as necessary. Check all bolts, replace as necessary.

2. Position control arm in front bracket and install bolt, lockwasher and nut. Do not tighten.

3. Slowly raise rear axle assembly until control arm rear bushing is aligned with bracket bolt hole. It may be necessary to line up bolt holes with a tapered punch to permit installation of bolt, lock washer and nut. Do not tighten.

4. Disconnect shock absorber at lower end. Lower rear axle assembly to allow positioning of spring in its seat on the lower control arm. Place a short piece of 2 x 4 between the lower end of the spring and axle housing. See Figure 7-20. This assembly aid holds the spring forward on the lower control arm to facilitate attachment of the spring to the lower control arm.

5. Insert spring seat between spring and control arm. Insert a long tapered punch

through the control arm bolt hole from the bottom to maintain alignment of the control arm and spring seat hole.

6. Slip spring clamp over punch and position straight side of clamp along straight end of spring.

7. Spring should be at frame top as follows:

Left - top spring end towards rear of car

Right - top spring end towards front of car

If springs are not positioned in this manner loosen top spring clamp bolts, reposition springs, and retorque spring clamp bolts to 17 ft. lbs. Hold spring in position, and with lower spring clamp plate correctly positioned, install bolt with nut on bottom and torque to 25 ft. lbs.

8. Raise rear axle assembly to reconnect shock absorber at lower bracket. Remove short piece of 2 x 4 behind spring.

9. Tighten shock absorber bolt to a minimum of 20 ft. lbs. and tighten control arm bushing bolts to 100 ft. lbs.

NOTE: Car should be in normal load position when tightening shock absorbers and lower control arms. Thus where possible car should be supported by wheel hoist, by axle contact hoist, or on wheel stands. If this is impossible due to equipment on hand, simulating normal load height with jack under rear axle housing could be done.

10. Carefully attach the propeller shaft to the rear companion flange observing the following precautions:

a. Compress the bearing cups using a 4" C-clamp to assure that the snap rings do not gouge the companion flange when seating. See Figure 6-45.

b. Do not use the U-bolts to draw the bearing cups into place. U-bolts should be seated and the nuts drawn up evenly.

11. Use torque wrench adapter J-9113 to torque U-bolts nuts to 13 ft. lbs.

12. Reinstall brake line bracket to rear suspension cross member.

13. Remove car stands and lower car.

b. Track Bar Service and Replacement

Removal

1. Raise car and support axle housing so weight of car will be on rear springs.

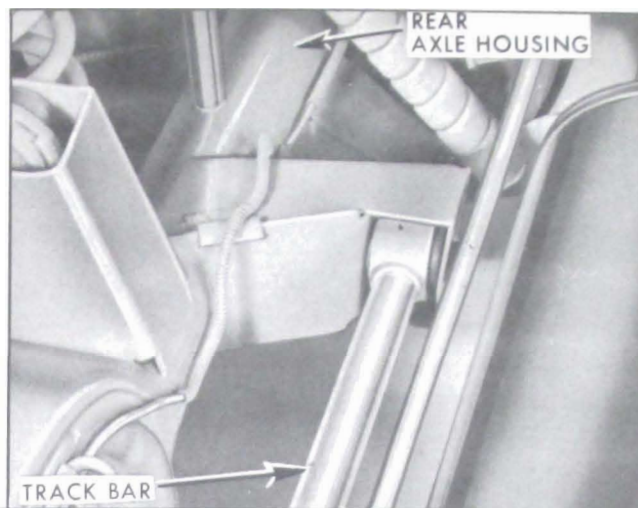

Figure 7-23—Track Bar-Axle Attachment

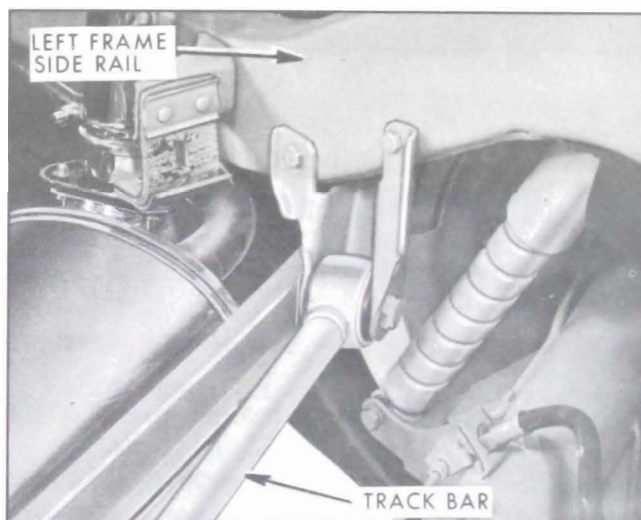

Figure 7-24—Track Bar-Frame Attachment

2. Remove pivot bolt and nut attaching track bar to bracket on axle housing.

3. Remove pivot bolt and nut attaching track bar to track bar bracket on left side of car.

4. Track bar can now be removed from brackets.

5. If track bar bracket is to be removed, remove three bolts, washers, and nuts attaching track bar bracket to frame side rails and remove track bar bracket. See Figure 7-24.

Inspection

1. If track bar is bent it should be replaced. No attempt should be made to straighten it.

2. Check rubber bushings for evidence of deterioration, tears, etc. Examine center steel sleeve for excessive wear or separation from rubber.

Removal and Replacement

1. Press out old bushing from side which has no flange using a ram 1 7/8" O.D. Considerable force may be required to remove the bushing.

2. Install new bushing in track bar eye by pressing on flanged side of bushing. Press in bushing until flange is in contact with eye of track bar.

Installation

NOTE: Track bar to bracket bolts must not be tightened unless car is at normal trim height.

1. If track bar bracket was removed install three bolts, washers, and nuts to attach track bar bracket to frame side rails. Torque to 45 ft. lbs.

2. Install pivot bolt and nut attaching track bar to track bar bracket on left side of car. Do not tighten.

3. Install pivot bolt and nut attaching track bar to bracket on axle housing. Torque nut to 120 ft. lbs.

4. Torque track bar nut on left side of car to 120 ft. lbs.

7-17 SHOCK ABSORBER SERVICE AND REPLACEMENT

a. Checking Shock Absorbers

Both front and rear shock absorbers are filled and sealed in production and cannot be refilled in service.

b. Removal and Installation of Front Shock Absorber

1. Remove upper mounting stem nut, grommet retainer and grommet. A 1/4" flat on shock stem may be used to hold stem while removing nut.

2. Remove two lower mounting bracket to lower control arm bolts. Lower shock through lower control arm.

3. Make certain the shock absorber being

installed is correct for car model as indicated by part number stamped on outer tube. See Master Parts List, Group 7.345.

4. Assemble lower grommet retainer and grommet on shock stem. Extend shock and install through lower control arm.

5. Install two shock bracket to lower control arm bolts and lock washers. Tighten to 20 ft. lbs.

6. Assemble top grommet, grommet retainer, and nut on stem.

c. Removal and Installation of Rear Shock Absorber

1. Raise rear of car.

2. Remove lower shock absorber mounting eye bolt and nut.

3. Remove upper shock absorber mounting nut, washer and bushing. Remove shock absorber.

4. Inspect all rubber bushings and grommets and replace if not in good condition. If shock absorber operation is faulty, it must be replaced as it cannot be repaired.

5. Make certain the new shock absorber is correct for car model as indicated by part number stamped on the outer tube. See Master Parts List, Group 7.345 for standard and optional parts.

6. Assemble bushing in upper shock eye. Place shock with bushing over stud in frame, install flat washer and nut. Torque nut to 40 ft. lbs.

7. Lower rear end of car. Then tighten pivot bolt to a minimum of 35 ft. lbs.

NOTE: Car weight must be on rear wheels when tightening shock absorber lower ends to clamp rubber bushings in a neutral position.

Shock absorber calibrations as furnished in production have been carefully engineered to provide the best ride control over a wide range of driving conditions. Substitution of other calibrations may adversely affect car performance and is not recommended by Buick Motor Division.

7-18 FRONT WHEEL ALIGNMENT

Wheel alignment is the mechanics of properly adjusting all the factors affecting the po-

sition of front wheels so as to cause the car to steer with the least effort and to reduce tire wear to a minimum.

Correct alignment of the frame is essential to proper alignment of front and rear wheels. Briefly, the essentials are that the frame must be square in plan view within specified limits, that the top and bottom surfaces of front cross member must be parallel fore and aft, and the bolt holes for support upper arms and lower control arm shafts must be of correct size and location. Checking frame alignment is covered in Group 12.

It should also be understood that wheel and tire balance has an important effect on steering and tire wear. If wheels and tires are out of balance, "shimmy" or "tramp" may develop or tires may wear unevenly, and give the erroneous impression that the wheels are not in proper alignment. For this reason, the wheel and tire assemblies should be known to be in proper balance before assuming that wheels are out of alignment.

Close limits on caster, front wheel camber, and theoretical king pin inclination are beneficial to car handling, but require only reasonable accuracy to provide normal tire life. With the type of front suspension used, the toe-in adjustment is much more important than caster and camber in so far as tire wear is concerned. Caster and camber adjustments need not be considered unless visual inspection shows these settings to be out, or unless the car gives poor handling on the road.

In the majority of cases, services consisting of inflating tires to specified pressure and interchanging tires at recommended intervals (par. 7-8) adjusting steering gear (par. 8-4 [manual] and par. 8-13 [power]), and setting toe-in correctly (subpar. e, below) will provide more improvement in car handling and tire wear than will front end alignment adjustments as usually made on front end alignment equipment.

The use of accurate front end alignment equipment is essential to determine whether front suspension parts have been damaged by shock or accident, and to obtain correct alignment settings after new parts have been installed.

a. Design Considerations Affecting Caster, Camber and Toe Change

The caster angle of an independent front

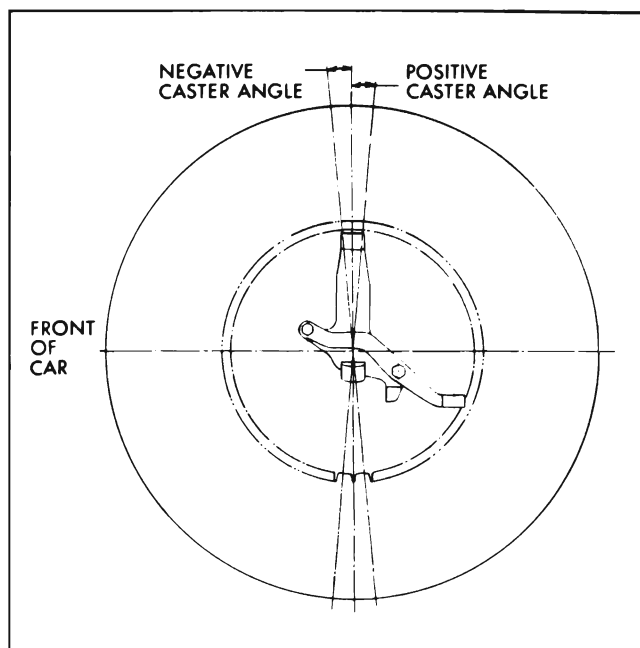

Figure 7-25—Caster Angle

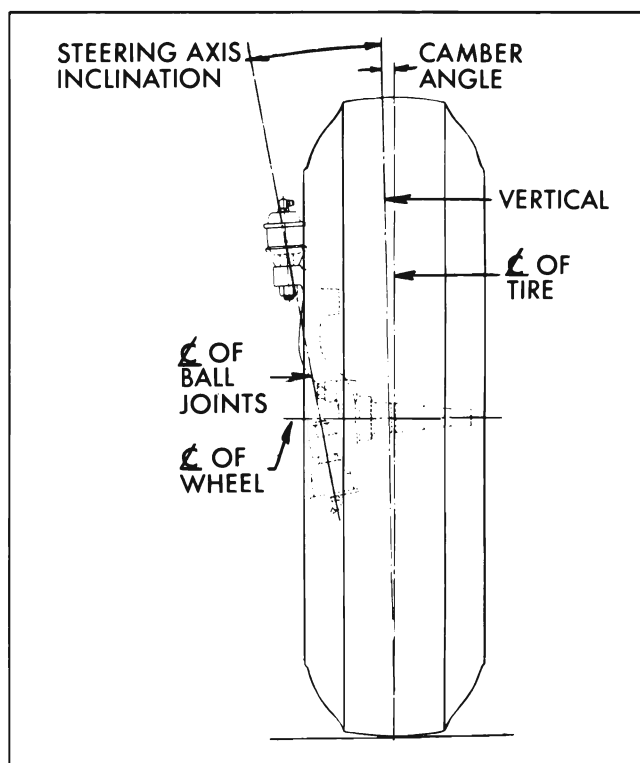

Figure 7-26—Camber Angle and Steering Axis Inclination

ball-joint suspension is the angle made by a line passing through the center of the upper and lower ball joints, and a vertical line through the centerline of the spindle in relation to the ground, when looking at the side of a car. The angle is called "positive" if the

upper ball joint is behind the lower, and "negative" if the upper ball is ahead of the lower. See Figure 7-25.

Once the caster has been set, the caster angle will change due to one or both of the following:

1. A change in trim height of the front suspension from the trim at which the caster was set.
2. A change in trim height of the rear suspension from the trim at which the caster was set.

The front suspension is attached to the front spring crossmember of the frame. The caster is determined by the angle of the line through the upper and lower front suspension ball joints to the ground. Therefore, the angle of the frame to the ground also controls the caster angle.

Since the caster and camber are in relation to the ground it is necessary to have tires, spindles, wheel bearings, and other related parts correct before setting front-end alignment.

b. Inspection Before Checking Front Wheel Alignment

Before any attempt is made to check or make any adjustment affecting caster, camber, toe-in, theoretical king pin inclination, or steering geometry, the following checks and inspections must be made to insure correctness of alignment equipment readings and alignment adjustments.

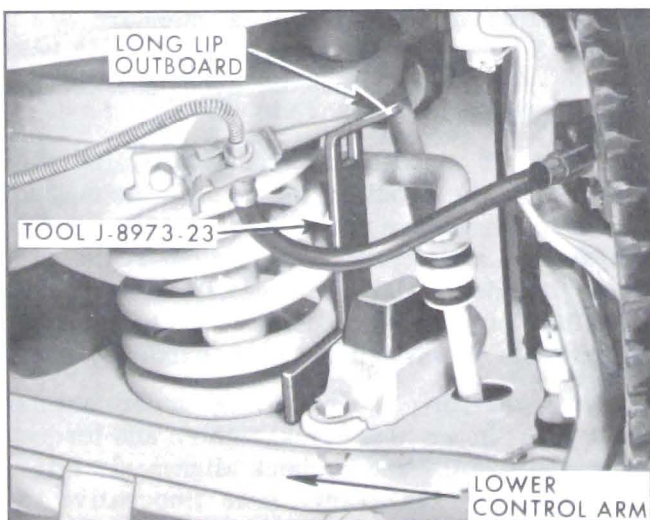

Figure 7-27—Front Alignment Height Tool in Place

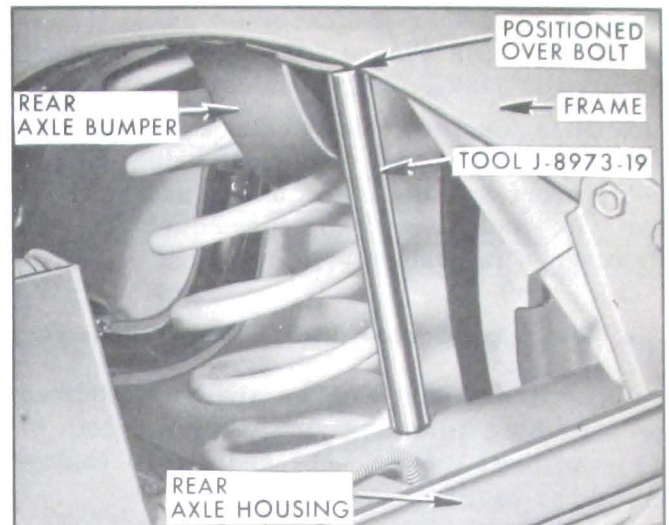

Figure 7-28—Rear Alignment Height Tool in Place

1. The front tires should have approximately the same wear and all tires must be inflated to specified pressures (par. 1-3).

2. Check front wheel bearings for looseness and adjust, if necessary (par. 7-10).

3. Check for run-out of wheels and tires and correct to within limit of 1/8" run-out at side of tires, if necessary. (par. 7-7).

4. Check wheels and tires for balance and correct if out of balance (par. 7-8).

5. Check for looseness at ball joints and tie rod ends; if found excessive it must be corrected before alignment readings will have any value (par. 7-5).

6. Check shock absorber action and correct if necessary (par. 7-5).

7. Check trim height, if out of limits, correct with shims or replace spring. **CAUTION:** Consideration must be given the optional equipment on the car, undercoating, dirt, etc.

Good judgment should be exercised before replacing a spring when car trim height is only slightly out of limits. Spring replacement under conditions of excessive weight as mentioned above will accomplish little and must be accompanied by shimming to obtain satisfactory results. 1/8" shims are available through Buick Parts warehouses under Group 7.425. Refer to paragraph 7-13.

8. Car must be on level surface. Install alignment height tool J-8973-23 between frame and lower control arm at each front wheel as shown in Figure 7-27. Use tool J-8973-19 in rear between frame and rear axle housing

with top of spacer positioned over bolt at rear of bumper. See Figure 7-28. These tools are included in J-8973, Alignment Set.

9. It is also advisable to check the condition and accuracy of any equipment being used to check front end alignment, and to make certain that instructions of the manufacturer are thoroughly understood.

c. Checking Caster and Camber Settings

Since caster and camber are both adjusted by shimming in the same locations, both of these settings must be checked before changing either setting.

CAUTION: Regardless of equipment used to check caster and camber, car must be on level surface both transversely and fore and aft. Since camber and caster vary in proportion to the height of the front springs, it is very important that the correct alignment height is maintained while checking (par. 7-18b).

Alignment height is used only when checking and adjusting caster and camber and should not be confused with trim height which is used to establish proper spring dimensions.

The use of height tools is necessary to maintain caster and camber at the specified design position. If height tools are not used, this definite position will vary according to the condition of the car. Undercoating, dirt and optional equipment all cause this position to vary. (It is not unusual to find 300 lbs. of dirt on a car).

When equipment is used which bears against the tire or wheel rim to obtain readings, it is very essential that the tires or wheels be checked for run-out. Readings must be taken at points which have no run-out or which lie in the same plane.

Caster and camber should be within the limits shown in Figure 7-30. Note that the caster angles at both front wheels need not be exactly the same but must be within $3/4$ degrees of each other. Likewise, the camber angles on both sides must be within $3/4$ degrees of each other. If caster and camber are not within the specified limits, adjust as described below.

d. Adjustment of Caster and Camber

Caster and camber may be adjusted by shimming at the upper control arm shaft attaching points. See Figure 7-29.

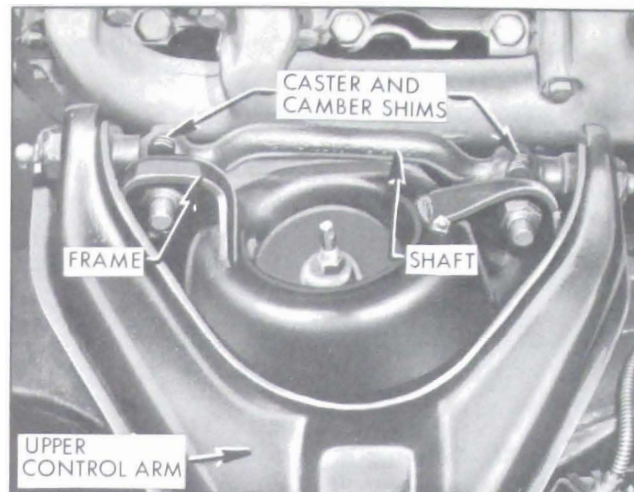

Figure 7-29—Upper Control Arm Shims

Production adjustment is done at the upper shaft locations using shims of .060", .080" and .100". The .080" shims are copper-plated for identification. The shims are horseshoe-shaped and at least one is used in each of the four upper locations. The shims are listed under Group 6.178 of the Master Parts List.

Addition or removal of upper control arm shims will change caster and camber settings. Due to the design of the upper control arm, changing shim patterns will affect both caster and camber at the same time. Thus care should be taken to watch both settings when changing one or the other.

To shim at the upper control arm shaft location, it is necessary to wedge the bolt heads to prevent turning, and loosen both front and rear nuts to free the shims for removal or addition. The nuts are accessible from under the car through the use of a standard $7/8$ " socket, 5" extension. A suitable $13/16$ " box or open-end wrench may be used to hold the head of the bolt.

To permit maximum accessibility to the nuts, raise the front of the car at the center of the front suspension cross member until both wheels are free. Suitably support the car on car stands. Raising the car in this manner will allow both upper control arms to come to the extreme downward position, exposing nuts.

After installing or removing upper shims (limit .500" in any one stack) tighten and torque upper shaft bolts and recheck alignment. Correct toe-in if necessary. It is imperative to adhere strictly to the torque specifications given in paragraph 7-1.

CHART
FRONT WHEEL ALIGNMENT
4400 - 4600 - 4800 SERIES

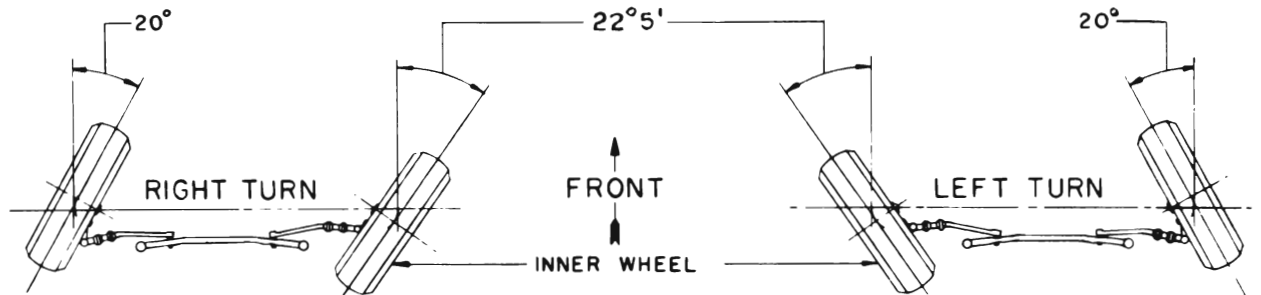

NOTE: WHEN OUTER WHEEL IS TURNED 20° THE INNER WHEEL TURNS — 22° 5'

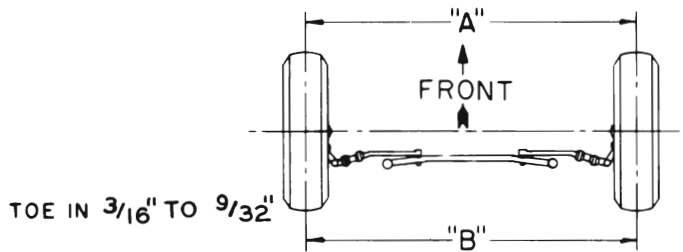

MEASURING FROM A ϕ SCRIBED ON TIRE OR FROM OUTSIDE OF FRONT TIRE, DISTANCE FROM ONE TO THE OTHER "A" SHOULD BE $\frac{3}{16}$ TO $\frac{9}{32}$ " LESS THAN "B"

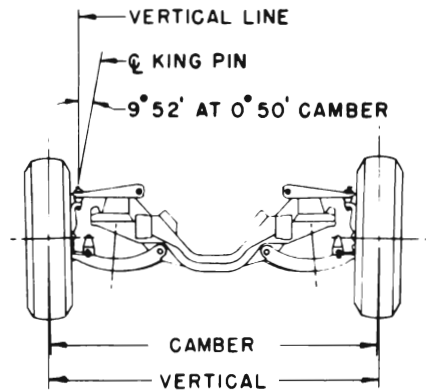
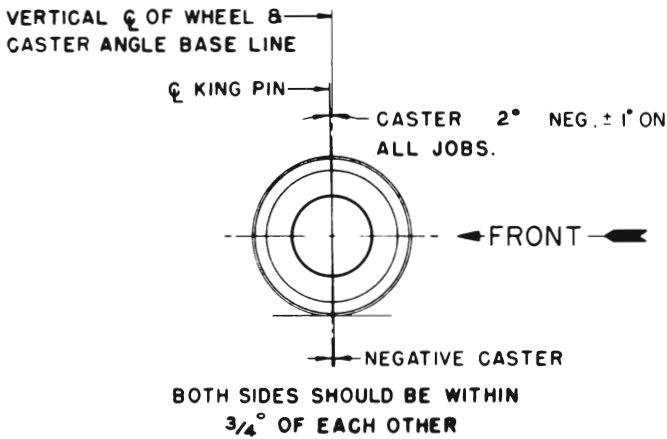

LIMITS OF CAMBER 1° POSITIVE TO $\frac{1}{2}$ ° NEGATIVE $\frac{1}{3}$ ° POSITIVE DESIRED—BOTH WHEELS. BOTH SIDES SHOULD BE WITHIN $\frac{3}{4}$ ° OF EACH OTHER.

NOTE: ALL MEASUREMENTS EXCEPT CASTER AND CAMBER TO BE TAKEN AT CURB WEIGHT WHICH INCLUDES GAS, OIL, WATER, SPARE TIRE, & CORRECT TIRE PRESSURE

CASTER & CAMBER SETTINGS MUST BE MADE USING J8973-23 FRONT ALIGNMENT HEIGHT TOOL & J8973-19 REAR ALIGNMENT HEIGHT TOOL FROM J8973 ALIGNMENT SET.

Figure 7-30—Alignment Specifications Chart

If customer driving habits require driving on heavily crowded roads and a resultant wandering condition becomes a complaint, camber can be set at the high limit on the left wheel whenever front end alignment is being performed.

A Guide to Caster - Camber Correction
1962 - 4400 - 4600 - 4800 Series

1. To Increase Camber Only -

Remove an equal amount of shims at front and rear bolt.

2. To Decrease Camber Only -

Add an equal amount of shims at front and rear bolt.

3. To Increase Caster Only -

Increase the amount of shims at the front bolt and decrease by an equal amount at the rear bolt.

4. To Decrease Caster Only -

Decrease the amount of shims at the front bolt and increase by an equal amount at the rear bolt.

5. To Increase Caster and
Camber Simultaneously -

Remove shims at rear bolt only.

6. To Decrease Caster and
Camber Simultaneously -

Add shims at rear bolt only.

e. Checking and Adjusting Toe-In

CAUTION: Car must be at curb weight and running height, (DO NOT USE ALIGNMENT HEIGHT TOOLS—bounce front end and allow it to settle to running height). Steering gear and front wheel bearings must be properly adjusted with no looseness at tie rod ends. The car should be moved forward one complete revolution of the wheels before the toe-in check and adjustment is started and the car should never be moved backward while making the check and adjustment.

1. Turn steering wheel to straight ahead position, with front wheels in straight ahead position.

2. Measure the horizontal distance from the near edge of front boss of lower control arm shaft to the front edge of brake backing plate, on each side. Adjust tie rods, if necessary, to make measurements equal on both sides.

3. Using a suitable toe-in gauge, measure the distance between outside walls of tires at the front at approximately 10" from the floor. See Figure 7-30 dimension "A". Mark points where gauge contacts tires. NOTE: An accurate check also can be made by raising and rotating front wheels to scribe a fine line near the center of each tire, then, with tires on the floor and front end at running height, measure between scribed lines with a suitable trammel.

4. Roll the car forward until measuring points on tires are approximately 10" from the floor at the rear, and measure the distance between points used in Step 3 above. The measurement at the front (dimension "A") should be 3/16" to 9/32" less than the measurement at the rear (dimension "B"). See Figure 7-30.

5. If toe-in is not within specified limits, loosen clamp bolts and turn adjusting sleeves at tie rod ends as required. Decrease toe-in by turning left sleeve in same direction as wheel rotates moving forward and turn right sleeve in opposite direction. Increase toe-in by turning both sleeves in opposite direction.

CAUTION: Left and right adjusting sleeves must be turned exactly the same amount but in opposite directions when changing toe-in, in order to maintain front wheels in straight ahead position when steering wheel is in straight ahead position. Tie rod sleeve clamps must be positioned straight down to 45° to provide frame clearance.

6. After correct toe-in is secured tighten clamp bolts securely.

CAUTION: The steering knuckle and steering arm "rock" or tilt as front wheel rises and falls. Therefore, it is of vital importance to position the bottom face of tie rod end parallel with machined surface at outer end of steering arm when tie rod length is adjusted. Severe damage and possible failure can result unless this precaution is observed.

f. Checking Steering Geometry (Turning Angles)

CAUTION: Be sure that caster, camber, and toe-in have all been properly corrected before checking steering geometry. Steering geometry must be checked with the weight of the car on the wheels.

1. With the front wheels resting on full floating turntables, turn wheels to the right

until the outside (left) wheel is set at 20 degrees. The inside (right) wheel should then set at angle specified in Figure 7-30.

2. Repeat this test by turning front wheels to the left until the outside (right) wheel sets at 20 degrees; the inside (left) wheel should then set at angle specified in Figure 7-30.

3. Errors in steering geometry generally indicate bent steering arms, but may also be caused by other incorrect front end factors. If the error is caused by a bent steering arm it must be replaced. Replacement of such parts must be followed by a complete front end check as described above.

g. Checking Theoretical King Pin Inclination

CAUTION: When checking theoretical king pin inclination, car must be on a level surface, both transversely and fore and aft. It must be maintained at specified alignment height while checking (par. 7-18b).

With camber known to be within specified limits, theoretical king pin inclination should check within specified limits given in Figure 7-30.

If camber is incorrect beyond limits of adjustment and theoretical king pin inclination is correct, or nearly so, a bent steering knuckle is indicated.

If camber and theoretical king pin inclination are both incorrect by approximately the same amounts, a bent upper or lower control arm is indicated.

There is no adjustment for theoretical king pin inclination as this factor depends upon the accuracy of the front suspension parts. Distorted parts should be replaced with new parts. The practice of heating and bending front suspension parts to correct errors is not recommended as this may produce soft spots in the metal in which fatigue and breakage may develop in service.