

SECTION 10-C GENERATING SYSTEM

CONTENTS OF SECTION 10-C

Paragraph	Subject	Page	Paragraph	Subject	Page
10-14	The Generating System	10-15	10-19	Bench Test of Generator	10-21
10-15	Description of Generator . . .	10-15	10-20	Generator Repairs - On Bench	10-22
10-16	Description of Generator Regulator	10-15	10-21	Test and Adjustment of Generator Regulator - on Car	10-24
10-17	Trouble-Shooting Generator System	10-18	10-22	Generator Regulator Repairs - On Bench	10-26
10-18	Inspecting and Testing Generator System	10-19			

10-14 THE GENERATING SYSTEM

The generating system restores to the battery the energy used in cranking the engine. It also supplies current to carry the electrical load of the ignition, lights, and all accessories, at operating speeds above 25 MPH. At speeds below 25 MPH the output of generator may not be sufficient to carry the electrical load of all units, therefore the battery supplies the additional current required.

The generating system consists of the generator (par. 10-15), generator regulator (par. 10-16), generator indicator light, battery (par. 10-7), the wires and cables connecting these units, and the battery ground cable and ground through engine crankcase which completes the circuit. See Figure 10-9.

The "GEN" indicator light when lighted is a warning which any driver cannot avoid noticing. It warns the driver that the generator is "dead," and therefore any accessories in use are drawing their electrical current from the battery. The "GEN" indicator light will be out whenever the generator is putting out sufficient voltage. However, it does not indicate whether the battery is being charged or discharged, but only whether the generator is "alive" or "dead."

NOTE: The indicator light will not show a blown fuse at normal city driving speeds.

10-15 DESCRIPTION OF GENERATOR

The generator is a two-brush, two-pole shunt wound unit. The generator is capable of delivering 35 amperes at 14 volts.

The maximum output of generator is controlled by the current regulator; however, the generator does not normally deliver the maximum output because the voltage regulator con-

trols output in accordance with the requirements of the battery and the current consuming units in operation. See Figure 10-9.

The generator pulley drives a fan which draws a draft of air through the generator to carry away the heat produced during operation. This ventilation permits the generator output to be increased to higher values than would be possible in a non-ventilated generator of the same size. See Figure 10-7.

The armature shaft is supported by annular ball bearings in both the drive end frame and the commutator end frame.

The two brushes are mounted in individual brush holders attached to the field frame and are held in contact with the commutator by spring loaded brush arms. One brush holder is grounded to the frame by the attaching rivet. The opposite brush holder is attached to the frame by a rivet and the "A" terminal screw but is completely insulated from the frame. The brush in this holder is connected to the field coils and to the "A" terminal screw. See Figure 10-7. Each field coil is held in place by a pole shoe attached to the frame by a large screw, and the coil is separated from its pole shoe by heavy insulation. See Figure 10-7.

The generator is mounted by hanging it from a bracket on the lower right side of the engine and is driven by the fan belt. The method of mounting permits the generator to be moved in or out to adjust the tension of the fan belt.

10-16 DESCRIPTION OF GENERATOR REGULATOR

The generator regulator is mounted to the rear of the battery and is cushioned by rubber

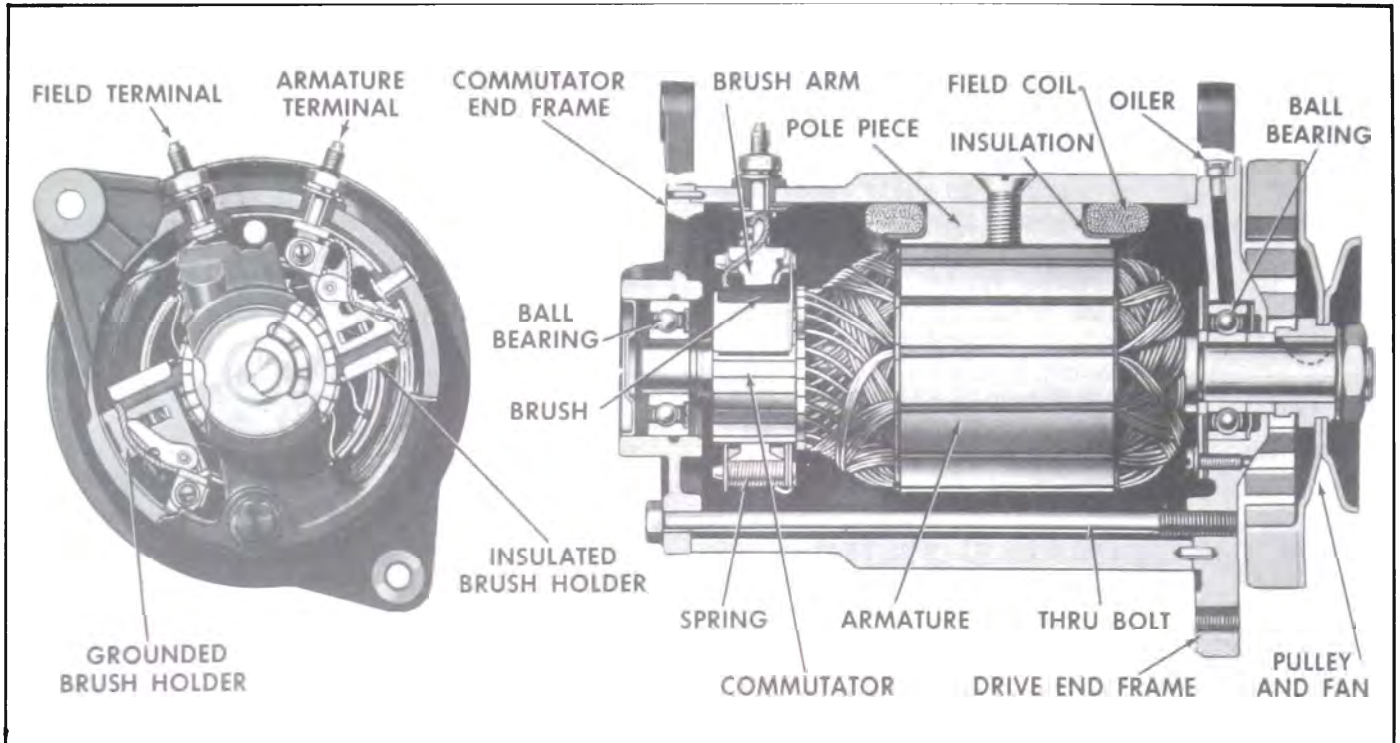

Figure 10-7—Generator, Sectional View

to dampen the vibration which is caused by engine operation. The regulator is grounded through two of the attaching bolts, and to insure a positive ground between the regulator and the generator, a wire connects the base of the regulator to the generator frame.

The generator regulator contains a cutout relay, current regulator, and voltage regulator, all mounted on one base and enclosed by a sheet metal cover. See Figure 10-8. These three

devices are magnetic switches whose functions and operations are as follows:

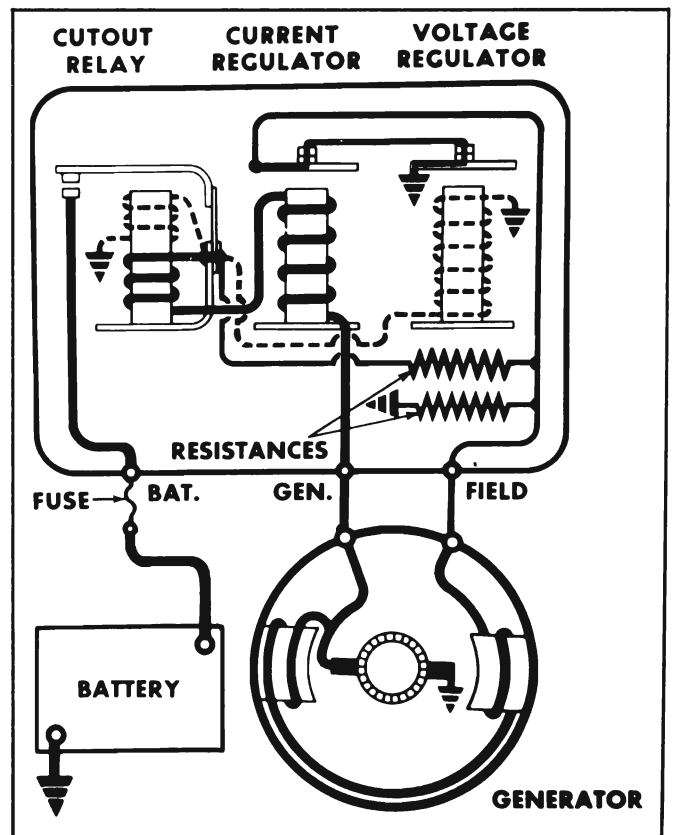

Figure 10-9—Generator System Circuits

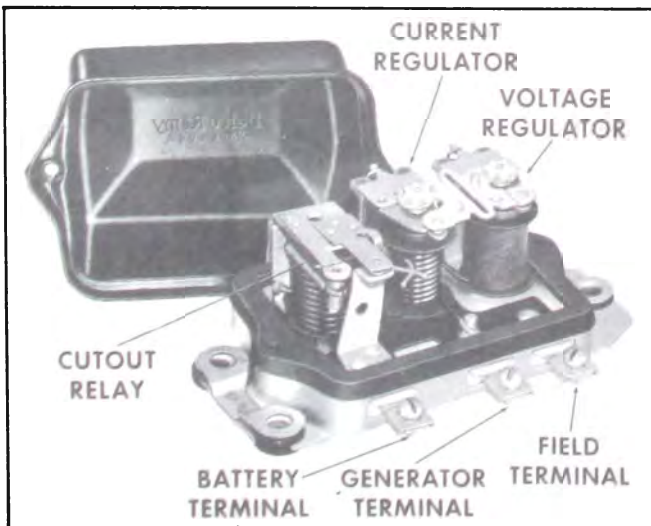

Figure 10-8—Generator Regulator

a. Cutout Relay

The cutout relay opens the circuit to prevent the battery from discharging to ground through the generator whenever the engine is stopped or generator is operating at such low speed that its voltage is less than voltage of battery. When the voltage of generator is slightly greater than battery voltage the relay closes the circuit so that generator can furnish current to the electrical system.

The cutout relay has a series or current winding of a few turns of heavy wire, and a shunt or voltage winding of many turns of fine wire, both assembled on the same core. The shunt winding is connected between generator armature and ground so that generator voltage is impressed upon it at all times. The series winding is connected so that all generator output current must pass through it. It is connected to a flat steel armature which has a pair of contact points through which current passes to the battery and other electrical units. The contact points are held open by armature spring tension when the unit is not operating. See Figure 10-9.

When the generator begins to operate, voltage builds up and forces current through the shunt winding, thereby magnetizing the core. When the voltage reaches the value for which the relay is set, the magnetism is strong enough to overcome the armature spring tension and pull the armature toward the core, thereby closing the contact points. Generator current now flows through the series winding of relay in the right direction to add to the magnetism holding the points closed, and passes on to the battery and other electrical units in operation.

When the generator slows to engine idling speed, or stops, current begins to flow from the battery back through the generator, reversing the current flow through the series winding. This reduces the magnetism of the relay core to the extent that it can no longer hold the contact points closed against armature spring tension. The points are separated and the circuit broken between the generator and battery.

All regulators have a fuse in the generator charging circuit. This fuse connects to the battery terminal of the regulator and the battery lead connects to it in turn. The purpose of the fuse is to protect the generator and wiring should a stuck or welded cutout relay occur. Shorts or grounds occurring in the charging

circuit or reverse polarity conditions of the generator can cause the cutout relay points to weld together. This allows the battery to discharge thru the generator when the generator is not developing greater than battery voltage. Since the generator has such low internal resistance, tremendously high current will flow from the battery causing wiring to burn and deterioration of the generator.

b. Current Regulator

The current regulator automatically controls the maximum output of the generator. When the current requirements of the electrical system are large and the battery is low, the current regulator operates to protect the generator from overload by limiting its output to a safe value.

The current regulator has one series winding of heavy wire through which the entire generator output flows at all times. This winding connects to the series winding in the cutout relay, described above. Above the winding core is an armature, with a pair of contact points which are held together by spring tension when the current regulator is not operating. When current regulator is not operating and the contact points are closed, the generator field circuit is directly grounded so that generator may produce maximum output, unless further controlled by the voltage regulator described below. See Figure 10-9.

When the generator output increases to the value for which the current regulator is set, the magnetism of the current winding is sufficient to overcome the armature spring tension. The armature is pulled toward the winding core so that the points are separated. The generator field circuit must then pass through a resistance, which reduces the flow through the field coils and thereby reduces the output of generator. This reduces the magnetic strength of the current winding so that spring tension again closes the contact points, directly grounding the generator field circuit and increasing generator output. This cycle is repeated many times a second, and the action limits the generator output to the value for which the regulator is set.

The current regulator has a bi-metal hinge on the armature for thermostatic temperature control. This automatically permits a somewhat higher generator output when the unit is cold, and causes the output to drop off as the

temperature increases.

The current regulator operates only when the condition of battery and the load of current-consuming units in operation require maximum output of the generator. When current requirements are small, the voltage regulator controls generator output. Either the current regulator or the voltage regulator operates at any one time; both regulators never operate at the same time.

c. Voltage Regulator

The voltage regulator limits the voltage in the charging circuits to a safe value, thereby controlling the charging rate of the generator in accordance with the requirements of the battery and the current-consuming electrical units in operation. When the battery is low, the generator output is near maximum but as the battery comes up to charge, and other requirements are small, the voltage regulator operates to limit the voltage, thereby reducing the generator output. This protects the battery from overcharge and the electrical system from high voltage.

The voltage regulator unit has a shunt winding consisting of many turns of fine wire which is connected across the generator. The winding and core are assembled into a frame. A flat steel armature is attached to the frame by a flexible hinge so that it is just above the end of the core. When the voltage regulator unit is not operating, the tension of a spiral spring holds the armature away from the core so that a point set is in contact which allows the generator field circuit to complete the ground through them. See Figure 10-9.

When the generator voltage reaches the value for which voltage regulator is set, the magnetic pull of the voltage winding is sufficient to overcome the armature spring tension, so that the armature is pulled toward the core and the contact points are separated. The instant the points separate, the field current flows only through the resistance to ground. This reduces the current flow through the field coils and decreases generator voltage and output.

The reduced voltage in the circuit causes a weakening of the magnetic field of the voltage winding in the regulator. The resulting loss of magnetism permits the spring to pull the armature away from the core and close the contact points again, thereby directly grounding

the generator field so that generator voltage and output increases.

This cycle is repeated many times a second, causing a vibrating action of the armature, and holds the generator voltage to a constant value. By maintaining a constant voltage, the voltage regulator continues to reduce the generator output as the battery comes up to charge. When the battery reaches a fully charged condition, the voltage regulator will have reduced the generator output to a relatively few amperes.

The voltage regulator has a bi-metal armature hinge for thermostatic temperature control. This automatically permits regulation to a higher voltage when the unit is cold, and a lower voltage when hot, because a high voltage is required to charge a cold battery.

As previously stated, the current and voltage regulators do not operate at the same time. When current requirements are large, the generator voltage is too low to cause voltage regulator to operate, therefore the current regulator operates to limit maximum output of generator. When current requirements are small, the generator voltage is increased to the value which causes voltage regulator to operate. The generator output is then reduced below the value required to operate the current regulator, consequently all control is then dependent on the operation of voltage regulator.

d. Resistances

The current and voltage regulator circuit both use the same resistance which is inserted in the field circuit when either regulator operates.

The sudden reduction in field current occurring when either the current or voltage regulator contact points open, is accomplished by a surge of induced voltage in the field coils as the strength of the magnetic fields change. These surges are partially dissipated by the two resistances, thus preventing excessive arcing at the contact points.

10-17 TROUBLE-SHOOTING GENERATOR SYSTEM

When a complaint is registered regarding operation of the generating system, trouble diagnosis should be governed by the following points.

a. Battery Runs Down

1. Visually check for a blown regulator fuse.
2. Light load test battery to see if battery is actually low. If low, quick-charge battery. Test battery to see if it is defective (par. 10-9).
3. If battery tests okay, run engine at approximately 1500 RPM (accessories off) and check charging voltage at battery terminals. Voltmeter should read 14 to 15 volts. If out of limits, test generator (par. 10-18) and regulator (par. 10-21).
4. If charging voltage is okay, but battery is low, check for a continuous short or ground in car electrical system.
5. If there is no short or ground and charging voltage is okay, car operating conditions may be such that generating system cannot keep up with electrical loss from battery. An occasional battery charge or a trickle charger may be necessary.

b. Battery Needs Water Too Often

Battery is probably overcharging due to charging voltage being too high. Check and adjust generator regulator, using a regulator temperature gauge to make sure voltage setting is correct according to temperature.

c. Generator Indicator Light Comes On Above Idle

If generator indicator light comes on only at slow idle, generating system is normal. However, if light comes on with engine running faster than idle, generator is not putting out sufficient voltage. Test generator (par. 10-18) and regulator (par. 10-21).

d. Generator Indicator Light Never Comes On

Generator indicator light should come on when ignition is turned on and before engine is started. If light does not come on, check light bulb or indicator circuit as necessary (par. 10-48).

inspected and tested every 5000 miles to determine its condition; however, the type of service in which some generators are used may make more frequent inspection advisable. High speed operation, excessive dust or dirt, high temperatures and operation of generator at or near full output most of the time are all factors which increase bearing, commutator and brush wear.

a. Inspection of Generator

The following inspection will disclose whether the generator is in proper condition for service or in need of removal for repairs.

1. Using a good light and a mirror, inspect the commutator through the openings in the commutator end frame. Low or unsteady output may result if the commutator is coated with grease or dirt, or is rough, out of round, or has high mica between the bars. If commutator bars are burned an open circuit is indicated.

2. Inspect commutator end of generator for thrown solder, indicating that generator has been overheated due to excessive output.

Excessive output usually results when the generator field is grounded, either internally or at the regulator. If this is indicated, disconnect the wire at "F" terminal of generator or regulator and run engine at medium speed. If generator output drops off the regulator is at fault but if output remains high the field is grounded internally in generator. If the field is found to be grounded, the regulator will probably have to be replaced.

3. Check condition of brushes; make sure they are not binding in holders and that they are resting on the commutator with sufficient tension to give good, firm contact. Brush leads and screws must be tight. If the brushes are worn down to one-half their original length, compared with new brushes, the generator must be removed for installation of new brushes.

4. If the commutator or brushes are in bad condition, other than being dirty, the generator should be removed for repairs (par. 10-20). If these parts are only dirty, however, they may be cleaned without removal of generator.

Clean off any grease with a cloth soaked with trichlorethylene or other non-inflammable solvent. A brush seating compound in paste form is particularly useful when seating brushes on

10-18 INSPECTING AND TESTING GENERATOR SYSTEM

As a general rule, the generator should be

extruded frame generators. To seat the brushes, place a small amount of this compound across the width of the commutator and operate the generator a short time. The abrasive particles of this compound are carried under the brushes and quickly wear the contacting faces to the contour of the commutator. All dust should be blown from the generator after the brushes are seated.

5. Check fan belt for condition and proper tension (Fig. 2-53), make certain that all generator mounting bracket and brace bolts are tight. A loose fan belt will permit belt slippage, resulting in rapid belt wear and low or erratic generator output. An excessively tight belt will cause rapid belt wear and rapid wear of generator and water pump bearings. **NOTE: If belt requires adjustment, first loosen belt so that generator pulley is free, then check pulley for tightness and check generator bearings for freeness of rotation and excessive side play. Rough or excessively worn bearings should be replaced.**

6. Inspect and manually check all wiring connections at generator, regulator, charge indicator, junction block and battery to make certain that connections are clean and tight. Clean any loose connections before tightening to insure good contact. Inspect wiring for broken insulation, broken strands, and loose terminals. Make any corrections necessary to eliminate excessive resistance.

b. Testing Generator Output

After inspection is completed, it is advisable to test the generator output.

1. Check generator belt tension and adjust as required.
2. Disconnect field lead from generator regulator "F" terminal and connect a jumper between this lead and ground. See Figure 10-10.
3. Disconnect battery lead from fuse at regulator "Bat" terminal. Connect test ammeter red lead to "Bat" terminal and ammeter black lead to battery lead. See Figure 10-10.
4. Connect a reliable tachometer between distributor terminal of coil and ground.
5. Turn on all accessory load (bright lights, hi blower, radio, etc).
6. Start engine and slowly increase engine

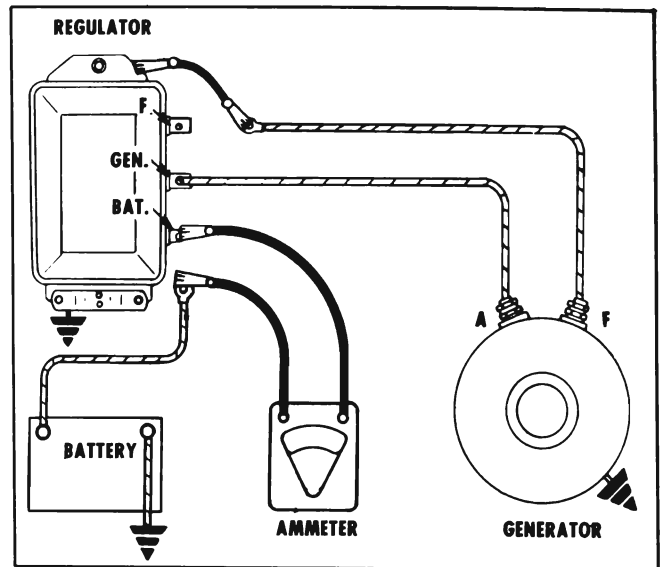

Figure 10-10—Testing Generator Output

speed until ammeter registers 35 amperes. At this generator output, engine speed should not be over 1200 RPM. Return engine speed to idle immediately after taking reading. **CAUTION: Never exceed 1200 RPM of engine with "F" lead grounded or the resulting high voltage may damage electrical units.**

7. If full ampere output cannot be obtained before 1200 RPM of engine, remove generator for testing and make the necessary corrections before attempting any adjustment of generator regulator.

c. Testing Charging Circuit Wiring

Excessive voltage drop in the charging circuit (resulting from poor connections or other high resistance) tends to keep the battery in an undercharged condition. To check voltage drop, proceed as follows:

1. Make sure that all accessories are turned off. Also make sure that ammeter is in place and that field lead is grounded. See Figure 10-11.
2. Operate engine at a speed which will produce a charge rate of 20 amperes.
3. Measure voltage drop at V-1, V-2, and V-3. Shut engine off immediately after taking readings. Readings V-1 and V-3 should not exceed 3 volt each. Reading V-2 should not exceed .1 volt. See Figure 10-11.
4. If any voltage reading exceeds these limits, excessive resistance is indicated in that

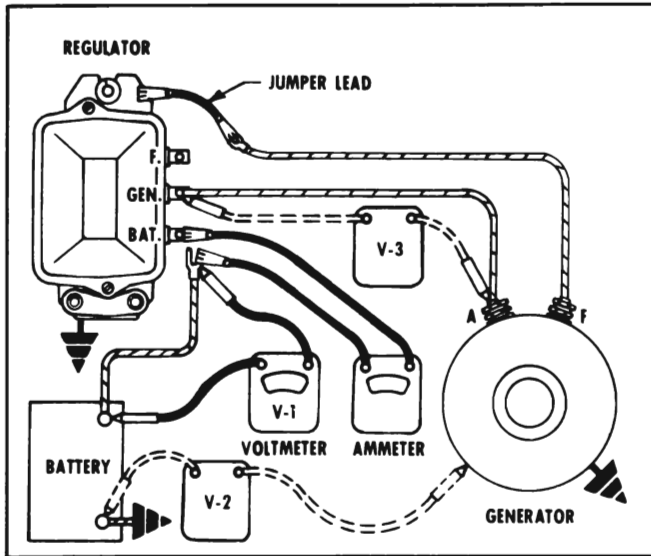

Figure 10-11—Testing Charging Circuit Voltage Drop

part of the charging circuit. To correct, clean and tighten connections; if this fails to reduce voltage drop, replace faulty wire.

5. Remove jumper and reconnect field lead to regulator "F" terminal.

d. Testing Regulator for Oxidized Points

Abnormal fluctuation of the voltmeter or ammeter pointer while testing the voltage or current regulator may indicate an oxidized condition of regulator contact points. This condition may cause a high resistance in the generator field circuit and reduced generator output. Test for oxidized contact points as follows:

1. With engine stopped, disconnect battery lead from fuse at regulator terminal marked "BAT". Connect ammeter red lead to fuse at "BAT" terminal and ammeter black lead to battery lead.

2. Turn on headlights. Start engine and adjust speed until test ammeter reads exactly 5 amperes.

3. Disconnect field lead from regulator "F" terminal and ground it on regulator base. See Figure 10-12. If ammeter reading increases more than 2 amperes, oxidized contact points are indicated. Regulator should be removed and contact points cleaned before proceeding to any other regulator tests. See paragraph 10-22 for cleaning procedure.

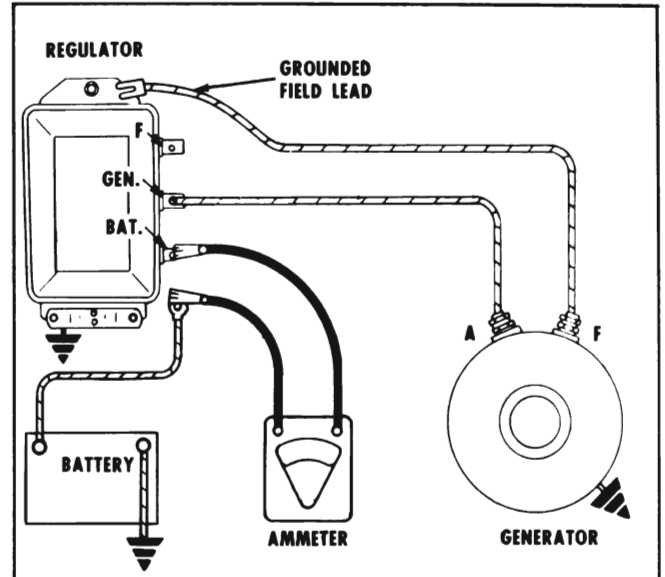

Figure 10-12—Testing Regulator for Oxidized Points

CAUTION: Never use a jumper to ground the generator or regulator field terminal when these units are connected and operating together, as this would burn the contacts of the voltage regulator.

10-19 BENCH TEST OF GENERATOR

The following inspection and test of generator, after removal from car, may be used to determine the cause of unsatisfactory output before generator is disassembled.

1. Inspect condition of brushes and commutator as described in paragraph 10-18. If brushes and commutator are in satisfactory condition and the cause of trouble is not apparent proceed to the following steps.

2. Place piece of cardboard between commutator and grounded brush. Using test lamp and points, check for grounds with test points on "A" terminal and generator frame. If lamp lights, the generator is internally grounded. Locate the ground by insulating the other brush also, and checking the brush holders, armature, commutator and field separately.

3. If generator is not grounded, check the field for open circuits by placing one test lamp point on the "F" terminal and the other point on the insulated brush holder to which the other end of field coil is connected. If lamp does not light the field has open circuit. If the open circuit is due to a broken lead or bad connections, it can be repaired but if the open circuit is in-

side one of the field coils the coil must be replaced.

4. If the field is not open, check for a short circuit by connecting a 12-volt battery and an ammeter in series with the field coils. Proceed with care since a shorted field may draw excessive current which might damage the ammeter. See paragraph 10-2 (a) for the field current draw specifications for the type generator being tested. A high reading indicates a short circuit.

5. If the cause of trouble has not been located, disassemble generator for test of armature (par. 10-20).

6. If a shorted field is found be sure to check for burned contact points in the generator regulator (par. 10-21) because a shorted field may permit an excessive field current which could burn the contact points.

7. When testing generator on a generator and regulator tester, a standard generator must be able to put out 35 amperes (cold) at 14 volts when generator speed is 2700 RPM.

10-20 GENERATOR REPAIRS— ON BENCH

a. Disassembly, Cleaning and Inspection

When it is necessary to disassemble generator for any reason, make a complete clean up and test to make sure all parts are in satisfactory condition. See Figure 10-13 for identification of generator parts.

1. Unscrew both through bolts and remove the commutator end frame from the field frame.

2. Disconnect brush leads and remove brushes from holders, then remove armature, drive end frame and pulley assembly from the field frame.

3. Hold armature in vise equipped with soft jaws. Avoid excessive tightening of vise. Remove pulley nut, lock washer, pulley, fan, key, collar, and drive end frame from armature shaft. Remove spacer washer.

4. Remove bearing retainer plate, gasket, bearing, plate and felt washer from drive end frame.

5. Thoroughly clean and inspect the ball bearings, and if satisfactory for use, pack

them with high melting point ball bearing grease. Replace worn or rough bearing.

6. Clean all other parts by wiping with clean cloths. The armature and field coils must not be cleaned in any degreasing compound since this might damage insulation so that a short or ground would subsequently develop.

7. Carefully inspect all parts for wear or damage and make necessary repairs, or replace unserviceable parts. Any soldering must be done with rosin flux; never use acid flux on electrical connections. If brush springs are distorted or show evidence of damage, replace them.

b. Testing and Repairing Armature

Before making any repairs to the armature, test it for open, shorted or grounded circuits.

Open circuits in armature are usually obvious since the open circuited commutator bars are usually burned as a result of arcing as they pass under the brushes. If generator has overheated and thrown solder, the open circuit will be at connections to commutator riser bars. Repair can be affected by resoldering leads to riser bars, using rosin flux.

Test for grounds, using test lamp and points, by placing one test point on armature core and the other test point on commutator. If lamp lights, the armature is grounded. If grounds are at points where coils come out of slots in core, repairs can be made by placing insulating strips between core and coil which is grounded.

Check armature for short circuits by placing it on a growler and slowly turning armature while holding a thin strip of steel (hacksaw blade) above armature core. The steel strip will vibrate when above the area of armature core in which any short circuited coils are located. Copper or brush dust in slots between commutator bars may cause shorts between bars which can be eliminated by cleaning out the slots. Shorts at cross-over of coils at the drive end can often be corrected by bending the wires slightly and reinsulating the exposed bare wire.

If armature is otherwise satisfactory but commutator is worn, burned, out of round, or has high mica between bars, the commutator should be turned true in a lathe. After turning, undercut mica 1/32", then carefully clean all

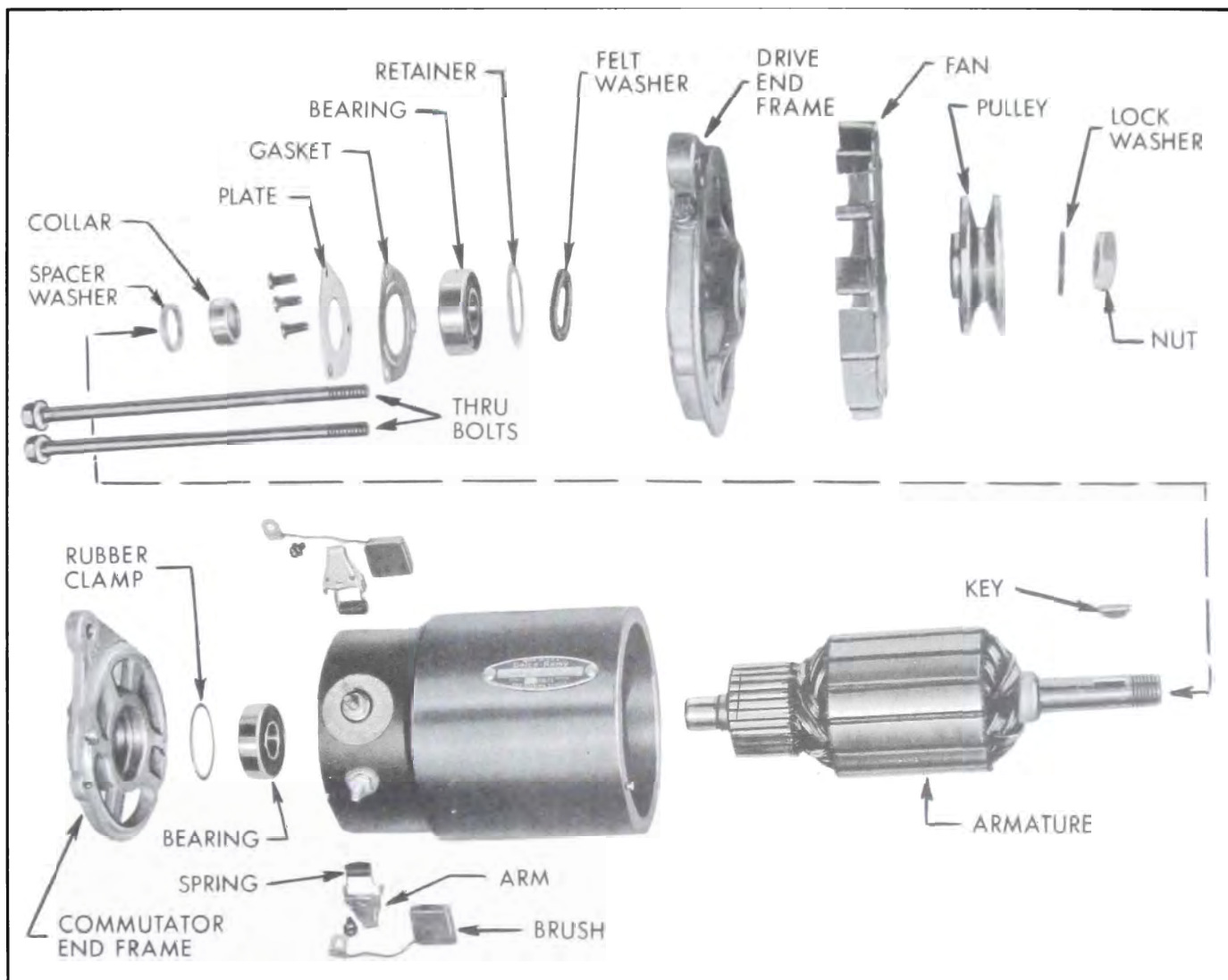

Figure 10-13—Generator Disassembled

dirt and copper dust out of slots. Lightly polish the commutator with 2/0 sandpaper to remove all slight burrs left by undercutting operation.

c. Replacement of Brush Holders

When it is necessary to replace a brush holder, drill out the attaching rivet with a No. 2 drill to remove old holder from the field frame. Attach the new brush holder with the screw, lockwasher, and nut provided in the brush holder service package.

When installing the insulated brush holder place insulating bushing on attaching screw with flat side against screw head. Locate screw and bushing in hole of brush holder, force flat-sided hole of insulating strip over screw threads, install parts in field frame and install

lockwasher and nut on screw finger tight. Thread the terminal stud through slot in brush holder and round hole in insulating strip, then install insulating bushing, flat washer, lockwasher, and nut. Tighten attaching screw and stud nuts securely. Attach field coil and brush leads to inner end of terminal stud.

d. Assembly and Installation of Generator

Assemble generator by reversing the disassembly procedure, paying attention to the following points:

1. If field coils were removed from the field frame be sure that insulation is placed between the coils and the pole shoes. Use care in tightening pole shoe screws to avoid distortion of parts, and make sure that screws are securely tightened.

2. New brushes must be seated to make good contact with armature, using a brush seating stone. This is a soft abrasive material which, when held against a revolving commutator, disintegrates so that particles are carried under the brushes and wear their contacting faces to the contour of the commutator in a few seconds. This operation may be performed on the bench if means are available for turning the armature, or it may be performed after generator is installed on engine. Blow all dust out of generator after the brushes are seated.

3. Connect the white armature wire to the "A" terminal of generator. This is the right hand terminal, farthest from engine. Connect the pink field wire to the left hand terminal.

CAUTION: Connect radio condenser to armature output "A" terminal.

4. Before the engine is started, momentarily bridge between the outer screw at the "BAT" terminal and the "GEN" terminal of the generator regulator with a jumper wire or screwdriver. This allows a momentary surge of current from battery to generator, which correctly polarizes the generator with respect to the battery. Adjust fan belt as shown in Figures 2-63 and 2-64.

10-21 TEST AND ADJUSTMENT OF GENERATOR REGULATOR—ON CAR

Before testing the generator regulator, make certain that the generator and circuit wiring are in good condition by performing the inspection and test given in paragraph 10-18. **CAUTION:** Never attempt to adjust the generator regulator without first hooking up a reliable test instrument. Serious damage to generator, battery, or other electrical units might result if regulator were adjusted improperly.

The following test procedures are written in general terms to cover use of any of the many reliable test instruments. For specific instructions, refer to the pamphlet which was received with your test instrument.

a. Test and Adjust Voltage Regulator

The voltage regulator should be tested whenever (1) difficulty is experienced in keeping the battery charged, (2) the battery uses an excessive amount of water, (3) there is evidence of damage to lights or other voltage-

sensitive equipment.

1. Before using tester, make sure all needles on instrument are properly calibrated.

2. Connect a tachometer from distributor terminal of coil to ground.

3. Connect a 1/4 ohm fixed resistor into charging circuit at "BAT" terminal of regulator. See Figure 10-14.

4. Connect a voltmeter from "BAT" terminal to ground on base plate of regulator.

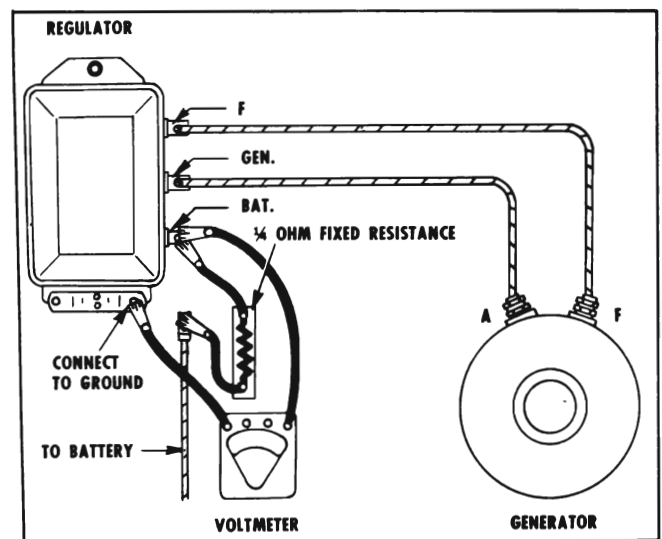

Figure 10-14—Testing Voltage Regulator

5. Install a reliable thermometer on regulator cover such as Gauge J-8529.

6. Operate engine at approximately 1500 RPM for 15 minutes to bring regulator to operating temperature.

7. Cycle generator by stopping engine, re-starting, and then operating engine at approximately 2000 RPM. Read voltmeter and thermometer. See Figure 10-15 to determine if voltage regulator setting is within limits for the existing temperature. If setting is within limits and battery condition has been satisfactory, voltage regulator should not be disturbed.

8. If necessary to adjust voltage regulator setting, increase spring tension to increase voltage setting, or decrease spring tension to decrease voltage setting. **CAUTION:** Final adjustment should always be made by increasing

Air Temperature at Regulator	85°	105°	125°	145°	165°
Voltage Setting	14.2-15.2	14.0-14.9	13.8-14.7	13.5-14.3	13.1-13.9
Current Setting	36.8-41.8	35.5-40.0	34.0-38.3	32.6-36.7	31.0-35.0

Figure 10-15—Chart for Setting Voltage and Current Regulators (After 15 Minute Warm-Up)

spring tension to assure contact between screw head and spring support.

9. After making an adjustment, replace cover, cycle generator, and recheck voltage regulator setting as described in Step 7.

b. Test and Adjust Cutout Relay

It is seldom necessary to check the cutout relay as long as the relay closes and opens the charging circuit properly.

1. Connect a voltmeter from "GEN" terminal to ground on base plate of regulator.

2. Connect a variable resistance into field circuit at "F" terminal and turn control knob to position for most resistance (open circuit). See Figure 10-16.

3. With engine operating at medium speed, slowly decrease resistance while watching voltmeter. Voltage reading will rise until cutout relay points close, then drop slightly as circuit is completed to battery. Closing voltage is the highest reading obtained just before it drops-off. Any reading within the specified range is satisfactory as long as the setting is at least .5 volt below the voltage regulator setting.

4. If necessary to adjust cutout relay setting, increase spring tension to increase closing voltage, or decrease spring tension to decrease closing voltage.

5. After making an adjustment, replace cover and recheck cutout relay closing voltage as

described in Step 3.

c. Test and Adjust Current Regulator

It is seldom necessary to check the current regulator unless the generator armature shows signs of overheating.

1. Connect a tachometer from distributor terminal of coil to ground.

2. Connect an ammeter into charging circuit at "BAT" terminal of regulator.

3. Install a reliable thermometer such as Gauge J-8529 on regulator cover.

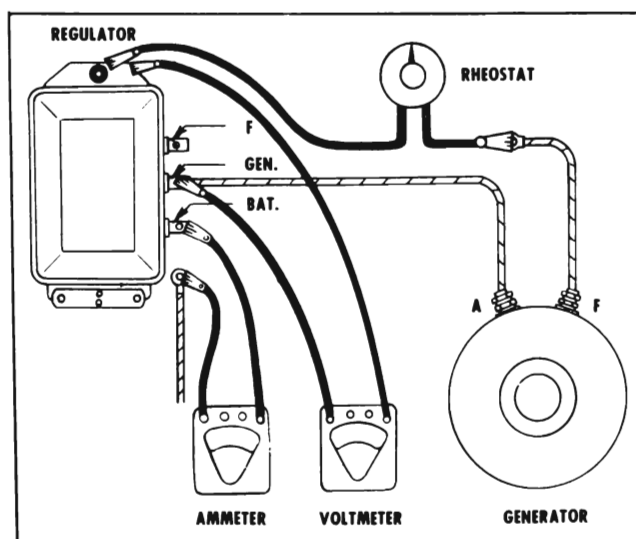

Figure 10-16—Testing Cutout Relay

4. Connect a variable load such as a carbon pile either across the battery or from the

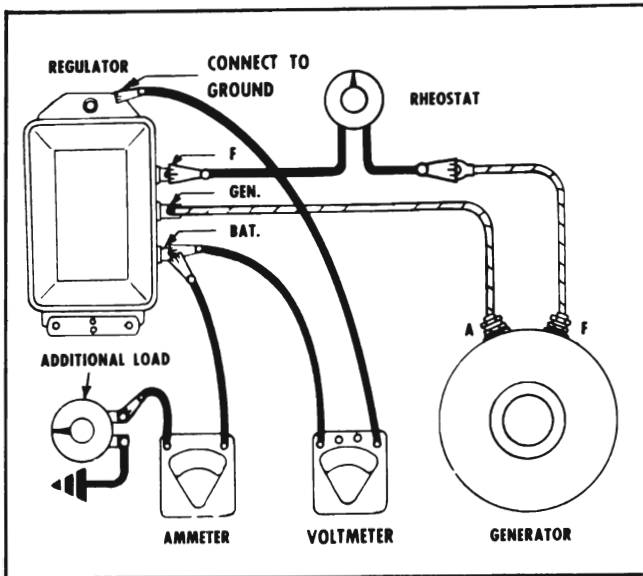

Figure 10-17—Testing Current Regulator

charging circuit to ground. See Figure 10-17. Turn control knob to position for lowest load (open circuit).

5. With engine operating at approximately 1500 RPM, slowly apply load while watching ammeter. Adjust load to obtain highest possible reading which is the current regulator setting. Read thermometer, then refer to Figure 10-15 for current setting for existing temperature. Any setting within the specified range is satisfactory.

6. If necessary to adjust current regulator setting, increase spring tension to increase current setting, or decrease spring tension to decrease current setting.

7. After making an adjustment, replace cover, cycle generator, and recheck current regulator setting as described in Step 5.

10-22 GENERATOR REGULATOR REPAIRS—ON BENCH

The contact points of a regulator will become oxidized and pitted after extended service and require cleaning. Contact points also may be burned because of faulty connections in the charging circuit, shorts or grounds in the generator field circuit, installation of a radio bypass condenser on the "F" terminal of generator or regulator, or accidentally grounding the generator or regulator field terminal while these units are connected and operating together.

The majority of regulator troubles arise from dirty and oxidized contact points, which cause a reduced generator output. If contact points are not badly burned, cleaning followed by testing and adjusting will correct faulty regulator operation in most cases. However, if contact points are badly burned, it is generally better to replace the generator regulator.

The contact points are of a soft material and should be cleaned with crocus cloth or a similar fine abrasive material. After cleaning, thoroughly wash the contact points with trichlorethylene or alcohol to remove any foreign particles.

CAUTION: Never use emery cloth or sandpaper on the contact points because particles of emery or sand may become imbedded and cause the points to arc and burn.

After thoroughly cleaning and washing the contacts, make the generator regulator tests and adjust if necessary. If the regulator still does not operate in a satisfactory manner, replace the regulator.