

## SECTION 10-E IGNITION SYSTEM

### CONTENTS OF SECTION 10-E

Paragraph	Subject	Page	Paragraph	Subject	Page
10-32	Ignition System Description and Operation . . . . .	10-37	10-36	Spark Plug and Wire Service	10-45
10-33	Ignition System - Trouble Diagnosis . . . . .	10-41	10-37	Ignition Coil Tests . . . . .	10-47
10-34	Replacement and Adjustment of Distributor Contact Point Set . . . . .	10-43	10-38	Distributor Condenser Tests .	10-48
10-35	Ignition Timing . . . . .	10-43	10-39	Distributor Service Operations . . . . .	10-49
			10-40	Ignition Switch and Lock Repairs . . . . .	10-52

### 10-32 IGNITION SYSTEM DESCRIPTION AND OPERATION

#### a. Ignition System Components

The ignition system consists of the ignition switch, ignition coil resistance wire, ignition coil, ignition distributor, spark plugs, and the low and high tension wiring. Electrical energy is obtained from the battery while cranking and during idle speeds, and from the generator at higher speeds. These supply circuits must be considered part of the ignition system.

1. Ignition Switch. The ignition switch has five positions. Starting with the full counterclockwise position, these positions are: "ACC.", "LOCK", "OFF", "ON" and "START". There are three positions between which the switch can be turned without the ignition key in the lock cylinder - "OFF", "ON" and "START". The ignition key can be freely inserted or removed in any position except "OFF" or "ACC." In "OFF", the key must be rotated slightly clockwise before it can be removed; this is to prevent the ignition switch from being left unlocked unintentionally. In "ACC.", the key cannot be removed; this is to prevent the radio or other accessories from being left on accidentally.

(a) In "ACC.", a connection is made from the battery terminal to the accessory terminal of the switch to allow accessories such as the radio, blower and/or windshield wiper to be operated with the ignition, fuel gauge and indicator light circuits off.

(b) In "LOCK", no accessory supplied through the ignition switch can be operated. Also, the

resistance wire circuit to the ignition coil (IGN-1) is grounded; this is to prevent the engine from being run illegally using a jumper to the coil.

(c) In "OFF", no accessory supplied through the switch can be operated.

(d) In "ON", a connection is made from the battery terminal to the accessory terminal so that all ignition switch supplied accessories can be operated. Also the battery is connected to the resistance wire leading to the ignition coil (IGN-1). From this same terminal, a lead into the instrument cluster energizes the fuel gauge and indicator lights.

(e) In "START", all ignition switch supplied accessories are temporarily disconnected. A connection is made to the starter solenoid lead and a second connection is made directly to the ignition coil (IGN-2). Also the water temperature light circuit is temporarily grounded to provide a means of checking the "TEMP." light bulb. When the ignition switch is released, a spring returns it to "ON".

2. Ignition Coil Resistance Wire. The ignition coil resistance wire is an integral part of the instrument panel wiring harness. This resistance wire is connected between the ignition switch wire and the positive (+) terminal of the coil. The resistance wire limits to a safe maximum the primary current flow through the coil and the distributor contact points, thereby protecting the contact points during slow speed operation when they are closed for longer-intervals. It also protects against excessive build up of primary current when the ignition switch is closed with engine stopped and contact points closed.

When the ignition switch is held in the "START" position, a connection is made from battery directly to the positive terminal of the ignition coil, bypassing the resistance. Elimination of the resistance overcomes the effects of reduced voltage due to cranking motor drain on the battery.

(3) **Ignition Coil.** The oil filled ignition coil is mounted on the front end of the intake manifold, adjacent to the ignition distributor. The positive (+) terminal is connected to the ignition switch through the resistance wire, and is also connected directly to the ignition switch to bypass the resistance wire during cranking of engine. The negative (-) terminal is connected to the distributor. The secondary (high tension) terminal is connected by a short cable to the center terminal in the distributor cap.

(4) **Ignition Distributor.** The ignition distributor is of the external adjustment type. It is driven clockwise directly from the camshaft through cast iron gears which are automatically lubricated by the engine oiling system. Contact point opening is adjusted through a window in the distributor cap while the engine is idling. Any accurate dwell meter may be used. See paragraph 10-34 for adjustment procedure.

The distributor is of the single contact type with an 8-lobe cam. High speed operation is improved by an especially light contact breaker arm and a high speed cam. Maximum operating efficiency of the engine is obtained under all speed and load conditions by the centrifugal advance mechanism, which is located above the circuit breaker cam inside the rotor, and the vacuum advance mechanism built into the distributor. See Figures 10-29 and 10-30.

The contact point set is replaced as one complete assembly. The service replacement contact set has the breaker lever spring tension and point alignment adjusted at the factory. Only the point opening requires adjusting after replacement.

(5) **Spark Plugs.** AC Type 45FFS spark plugs having 14 MM threads, short (3/8") terminals, and .035" gaps are specified for normal operation.

(6) **Radio Suppression.** All secondary wiring has a resistance of 4000 ohms per foot so that it is unnecessary to install a suppressor on the high tension cable when a radio is installed. A capacitor is mounted on the side of ignition coil and connected to the positive (battery) terminal of coil when a radio is installed.

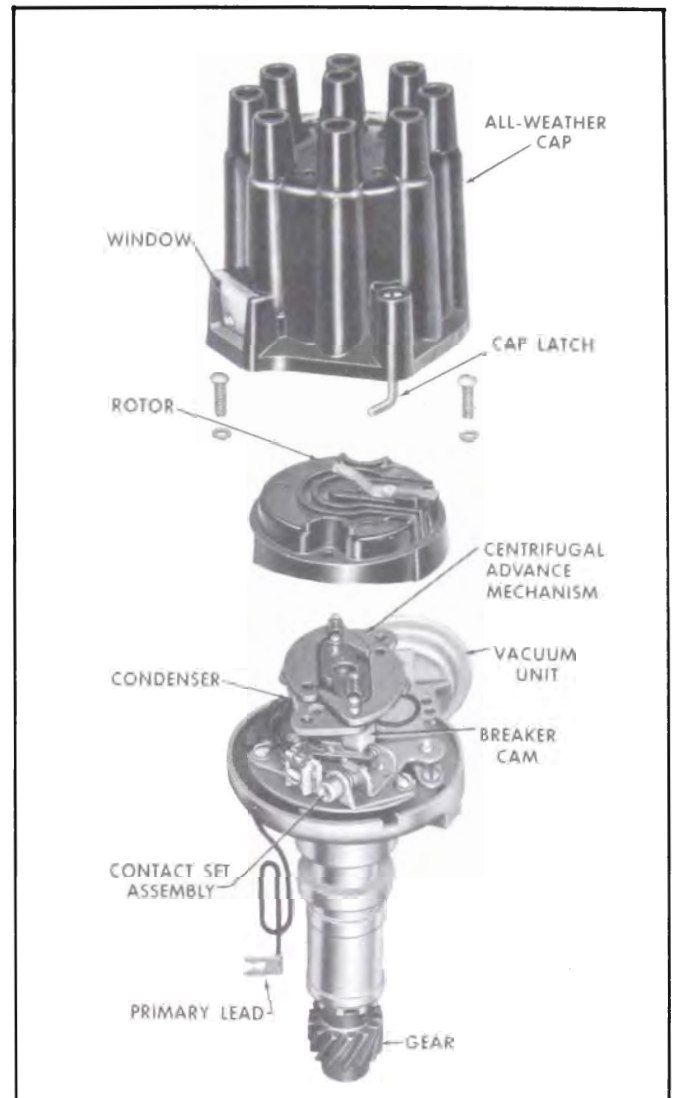

Figure 10-28—Distributor and Cap Assembly

An additional capacitor must never be connected to the distributor terminal as this will cause excessive pitting of breaker points or engine missing.

### b. Ignition Operating Circuits

To clarify operating principles as well as to simplify the process of tracing troubles, the parts of the ignition system should be understood to provide two separate and distinct circuits, as follows:

1. **The Primary Circuit** carries the low voltage current supplied by the battery or generator. In addition to these sources of electrical energy, the primary circuit contains the ignition switch, ignition coil resistance unit, primary winding of the ignition coil, distributor contact points, condenser, and all connecting low tension wiring.

2. The Secondary Circuit carries the high voltage surges produced by the ignition coil, which result in high voltage spark between the electrodes of the spark plugs in engine cylinders. This circuit contains the secondary winding of the ignition coil, coil to distributor high tension lead, distributor rotor and cap, ignition cables, and spark plugs.

### c. Cycle of Operation

When the ignition switch is turned on and the distributor contact points are closed, battery or generator current flows through the primary winding of the coil and through the contact points to ground. This flow of current through the primary winding of the coil produces a magnetic field around the coil windings and thereby stores electrical energy in the coil.

When the contact points are separated by the revolving distributor cam, the primary circuit is broken. The condenser absorbs the current which tends to surge across the gap as the points separate, thereby producing a sharp break in the flow of current. If the flow of current were not sharply broken it would form an arc which would burn the points badly and would also drain away most of the energy stored in the coil. There would be insufficient energy left in the coil to produce the necessary high voltage surge in the secondary circuit.

The very rapid change in strength of the magnetic field when the primary circuit is sharply broken causes a high voltage to be induced in every turn of both the primary and secondary windings.

The high voltage surge produced in the secondary winding of the coil travels through the cable to the center of distributor cap, through the rotor to the adjacent distributor cap segment from which it is conducted to the proper spark plug by the ignition cable. The high voltage surge jumps the gap between the insulated center electrode and the grounded side electrode of the spark plug, thus producing the spark required to ignite the charge in the selected combustion chamber of the engine.

As the spark appears at the spark plug gap the energy in the coil begins to drain from the coil through the secondary circuit, thus sustaining the spark for a small fraction of a second. During this interval the condenser discharges back through the primary circuit, producing an oscillation of the current flow

in the primary circuit during the brief instant that is required for the primary circuit to return to a state of equilibrium. Note particularly that the ignition condenser does not discharge until after the spark has occurred at the spark plug gap.

The sequence of action described above is repeated as each lobe of the distributor cam moves under and past the rubbing block on the contact breaker arm to cause the contact points to close and open.

### d. Control of Spark Timing

The timing of the spark with respect to piston position in the cylinder must vary in accordance with operating conditions if best engine performance is obtained. The spark advance for obtaining satisfactory idling should be as low as possible. At high speed, the spark must occur earlier in the compression stroke in order to give the fuel-air mixture ample time to ignite, burn and deliver its power to the piston as it starts down on the power stroke.

Under part throttle light load operation, a smaller amount of fuel-air mixture (by weight) enters the cylinder so that the mixture is less highly compressed. Under this condition, advancing the spark permits fuller utilization of the fuel-air charge. During acceleration or on heavy loads (wide open throttle) the spark advance required to develop the maximum power of the engine is considerably less than that required for light loads.

Control of spark timing to satisfy these constantly changing operating requirements is obtained in three ways, as follows:

1. Initial, manual setting of distributor is made so that contact points open at a specified position of piston, as indicated by a timing mark on crankshaft balancer. See Ignition Timing (par. 10-35).

2. Centrifugal Advance is governed by engine speed. The centrifugal advance mechanism is located above the circuit breaker cam inside the rotor and consists of an advance cam which is integral with the distributor shaft, a pair of advance weights, two springs, and a weight base plate which is assembled to the distributor cam.

At idle speeds, the springs hold the advance weights as shown in Figure 10-29A, so that there



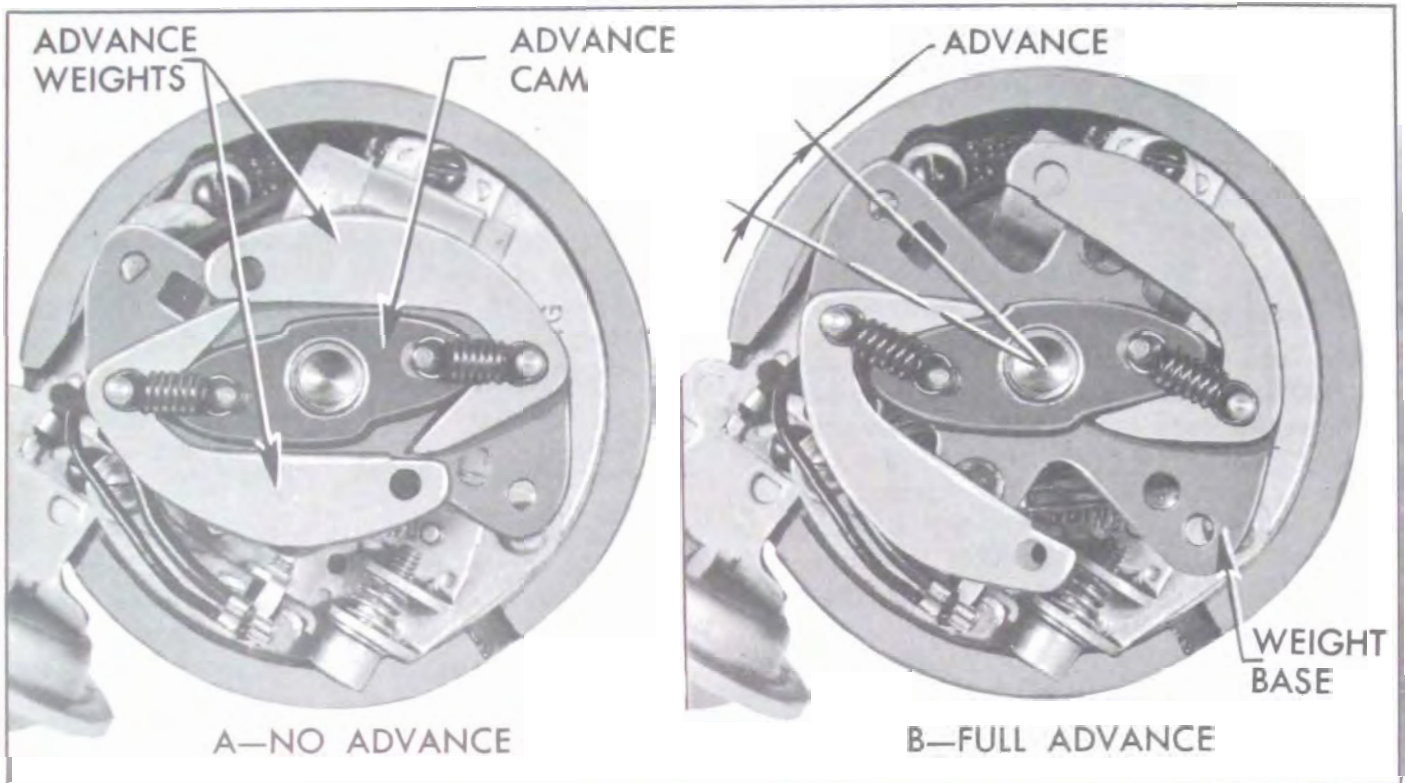

Figure 10-29—Centrifugal Advance Mechanism

is no spark advance and the spark occurs in accordance with the initial manual setting of distributor.

As speed increases, centrifugal force causes the advance weights to throw outward and push against the advance cam, thus rotating the weight base plate and integral distributor cam ahead of the distributor shaft. This causes the distributor cam lobes to open and close the contact points earlier in the compression stroke so that the spark is advanced. See Figure 10-29B.

3. **Vacuum Advance** is governed by manifold vacuum. The contact point set is mounted on a breaker plate which is located below the centrifugal advance mechanism and uses the outer diameter of the upper shaft bushing for its bearing surface. The movable breaker plate is held in position on the upper shaft bushing by a retainer. The vacuum unit is mounted on the distributor base and under the movable breaker plate so that the breaker plate can be rotated around the distributor cam by a link from the vacuum unit. See Figure 10-30.

The vacuum unit contains a spring-loaded diaphragm. The spring-loaded side of the diaphragm is connected by a pipe to an opening in the carburetor barrel. This opening is on the

atmospheric side of the throttle valve when the throttle is in idling position so that there will be no vacuum to operate the advance mechanism.

When the throttle valve is opened slightly, the vacuum at the opening is sufficient to act on the control diaphragm, causing it to compress the spring and to rotate the breaker plate in a counter-clockwise direction. This moves the contact points so that the distributor cam

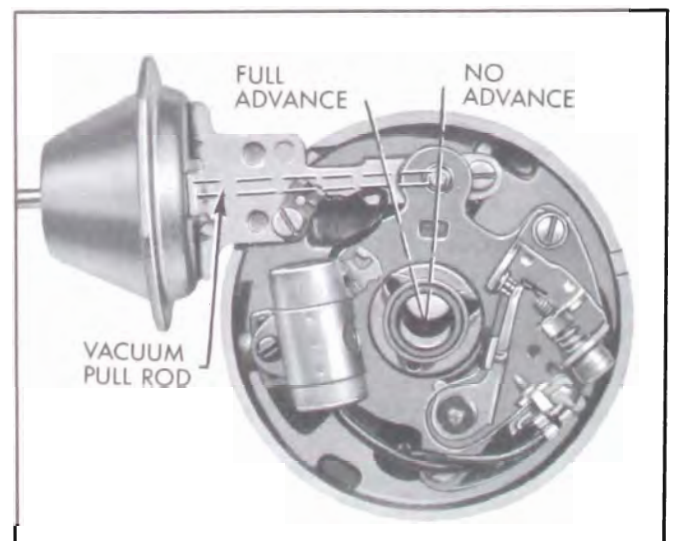

Figure 10-30—Vacuum Advance Mechanism

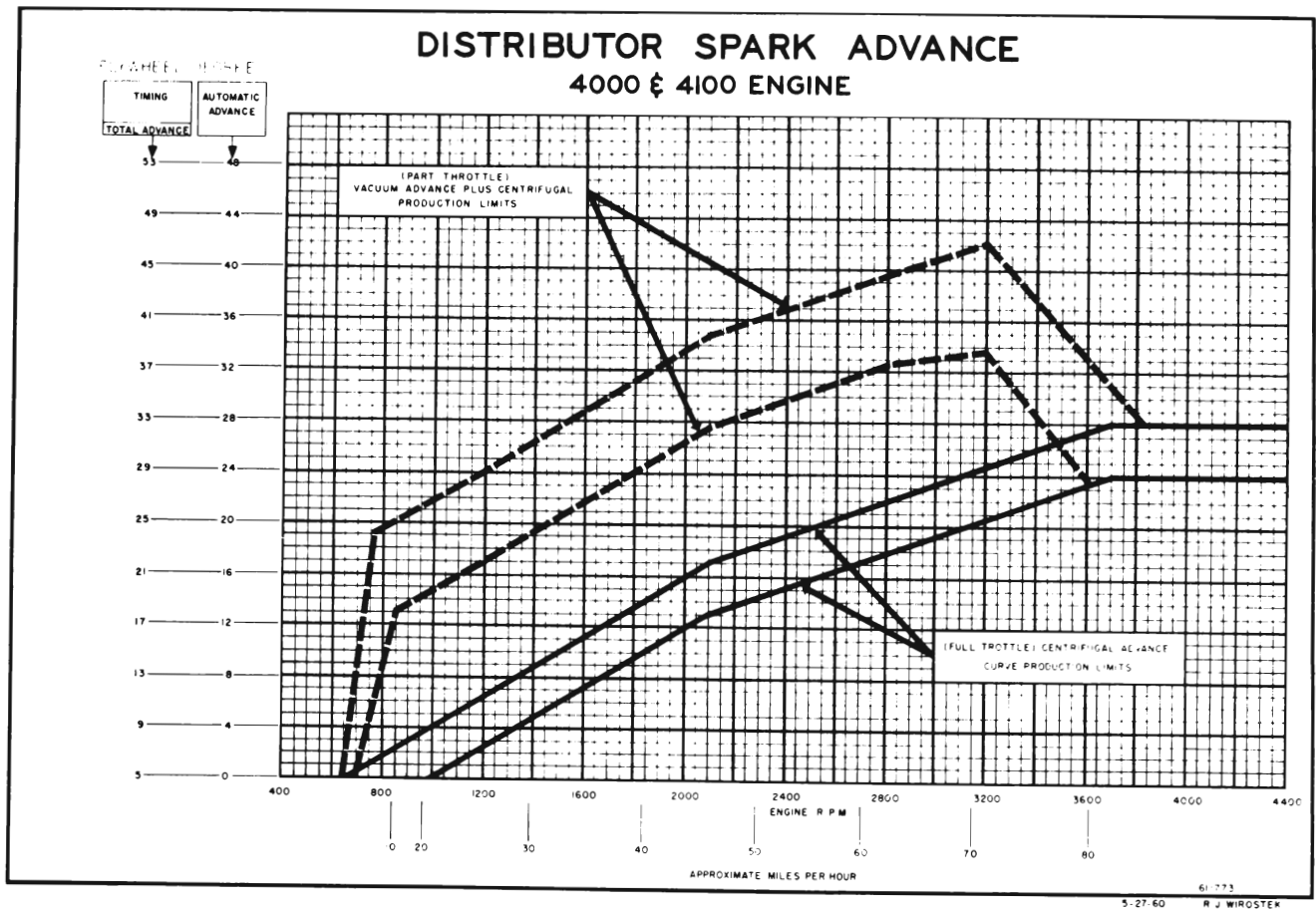

Figure 10-31—Distributor Spark Advance Chart (V-8 Engine)

lobes open the points earlier in the compression stroke. The amount of throttle opening and the engine load determine the amount of intake manifold vacuum and thus the amount of spark advance obtained. The advance obtained by the vacuum control is added to the advance obtained by the centrifugal advance mechanism as shown in Figure 10-31.

### 10-33 IGNITION SYSTEM— TROUBLE DIAGNOSIS

If engine trouble has arisen which seems to be due to improper operation of the ignition system, it may be desirable to make a quick preliminary check of the ignition system before making a complete analysis, in order to determine whether the ignition system is actually at fault. The quick checks described in this paragraph may be used but it must be understood that they are no substitute for the complete ignition system inspection. The checks to be made depend on whether the engine will or will not run.

#### a. Engine Will Not Run

1. Make quick check of battery and cables (par. 10-11) if cranking motor does not turn engine at normal cranking speed.

2. Pull coil high tension cable from distributor cap and hold the lead terminal about 3/16" from a clean ground point on engine. If a good spark occurs while engine is being cranked, the primary circuit and the secondary circuit to this point may be considered to be okay. Proceed with steps 3 through 6.

3. Remove distributor cap and check interior for moisture, corroded terminal segments, and check terminal sockets for corrosion. Check rotor for corrosion. Clean off corrosion and wipe distributor cap dry. Check for a crack or carbon path in cap or rotor.

4. Inspect ignition cables for possible short circuits and corroded terminals. Remove and inspect spark plugs (par. 10-36).

5. If cause of trouble has not been found, check approximate ignition timing (par. 10-35).

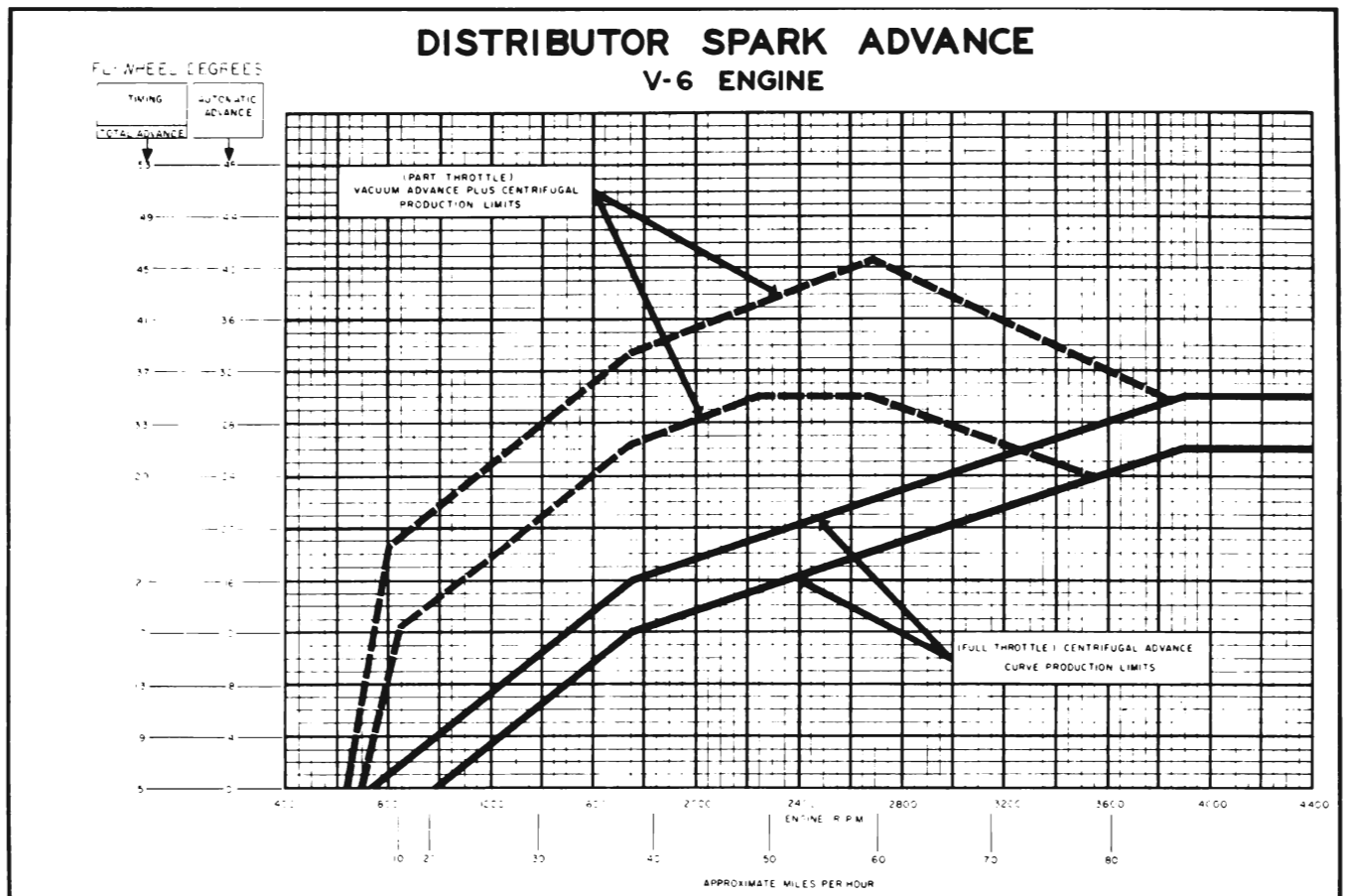

Figure 10-32—Distributor Spark Advance Chart (V-6 Engine)

6. If engine still fails to run, the trouble is probably due to causes other than ignition, such as lack of fuel, carburetion, or compression loss.

7. If spark did not occur at coil high tension lead (step 2 above) then connect 12-volt test lamp between distributor terminal of coil and ground and crank engine. If test light flickers on and off as engine is cranked the primary circuit is probably okay. Check ignition coil (par. 10-37) and condenser (par. 10-38).

8. If test light remains on as engine is cranked, contact points are not closing properly; check point opening and ground connection in distributor (par. 10-39).

9. If test light remains off as engine is cranked, the primary circuit is open or the points are not opening properly. Check for loose connections, broken leads, defective switch, contact point opening, and primary circuit winding in coil. Visual inspection of points and the use of a test lamp or voltmeter will locate the source of this trouble.

### b. Engine Runs, But Not Satisfactorily

1. When missing, loss of power, or hard starting is present a complete checkup of the ignition system is in order, since these conditions may result from anything from a low battery to defective spark plugs, or from other engine conditions not related to ignition. In this case, the complete inspection of ignition system should be used.

2. Detonation may be caused by improper timing (par. 10-35), improper operation of centrifugal or vacuum advance mechanism (par. 10-32, d), worn distributor bearings or a bent shaft, dirty or wrong heat range spark plugs (par. 10-36). It may also be caused by overheating, excessive carbon in cylinders, or by low octane fuel.

3. Overheating may be caused by one or more of the conditions which contribute to detonation, as well as by faults in engine cooling system.



### 10-34 REPLACEMENT AND ADJUSTMENT OF DISTRIBUTOR CONTACT POINT SET

When inspection of the contact points as described in paragraph 10-39 shows replacement to be advisable, the following procedure should be used.

NOTE: The service replacement contact point set has the breaker spring tension and point alignment adjusted at the factory.

#### a. Removal of Contact Point Set

1. Remove distributor cap by inserting a screwdriver in upper slotted end of cap retainers, press down and turn 90° counterclockwise. Push distributor cap aside and remove rotor. Disconnect the condenser and primary leads from their terminal by loosening the retaining screw.

2. Loosen two screws and lockwashers which hold the contact point set in place. Then remove point set.

#### b. Installation of Contact Point Set

1. Slide contact point set over boss on breaker plate and under the two screw heads. Tighten two screws and lockwashers.

2. Install condenser and primary leads.

NOTE: Leads must be properly positioned so they will not come in contact with bottom of weight base or rotor.

3. If engine does not start readily, position contact arm rubbing block on peak of cam lobe, insert a 1/8" Allen wrench in adjusting screw and turn screw in (clockwise) until contact points just close. Then back screw out (counterclockwise) 1/2 turn (180°) to obtain a point gap of approximately .015" for a preliminary setting.

#### c. Adjustment of Contact Points—Engine Running

NOTE: When adjusting contact point dwell angle, always follow the instructions which come with the dwell meter.

1. Connect dwell tester leads: red to distributor side of coil, black to ground.

2. Turn selector switch to position for 8-lobe cam. Turn ignition switch on.

3. Start engine. Lift adjustment window and insert 1/8" Allen wrench in adjusting screw. See Figure 10-33. Set dwell angle at 30 degrees.

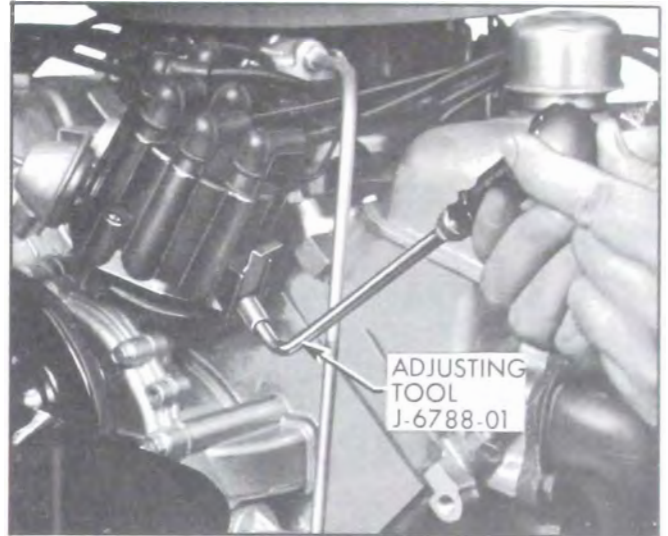

Figure 10-33—Adjusting Contact Point Dwell Angle

4. After adjusting dwell angle, always check ignition timing.

### 10-35 IGNITION TIMING

The timing mark is a groove filled with yellow paint, which is on the rear edge of the harmonic balancer. The timing indicator, a part of the timing chain cover, has three ridges outlined with yellow paint. These ridges indicate U.D.C. (marked "0"), "5" degrees, and "10" degrees before U.D.C. See Figure 10-34.

Correct timing exists when the yellow timing mark on the harmonic balancer is aligned with the "5" on the timing indicator with the engine running at a slow idle. (Hi performance automatic transmission engines should be timed at 7-1/2 if timed at slow idle.) Firing then occurs at the proper time before the piston reaches upper dead center.

#### a. Preliminary Timing (Engine Won't Run)

To time the ignition on any engine which will run, use subparagraph b only. However, if the

timing of an engine is completely off, the following procedure must first be used to get the engine to run.

1. With left rocker arm cover removed, rotate crankshaft in a forward direction using a suitable wrench on the harmonic balancer to crankshaft bolt. Continue rotation until both valves for No. 1 cylinder are completely closed and the timing mark on balancer is aligned with the proper mark on timing indicator. See Figure 10-34. No. 1 cylinder is now in position to fire.

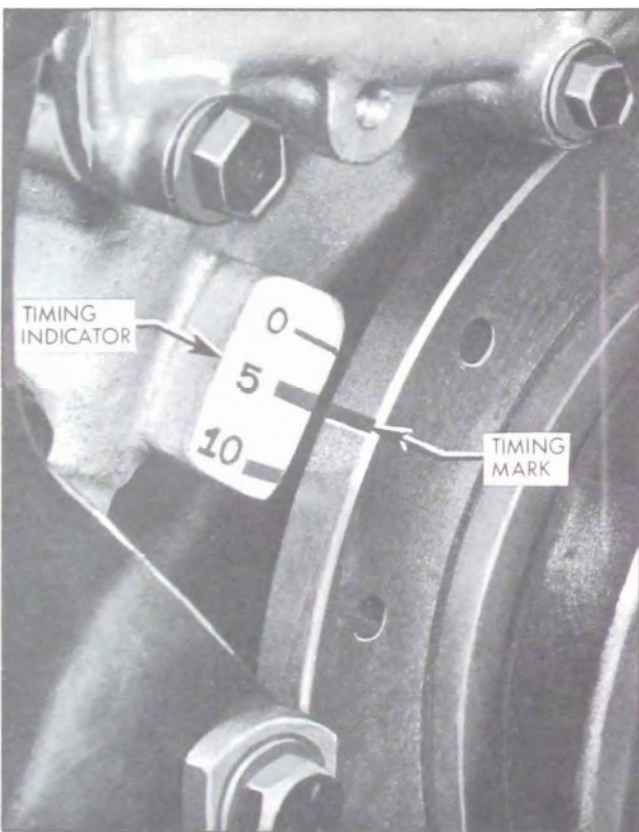

Figure 10-34—Ignition Timing Mark and Indicator

2. Install distributor in engine with rotor in position to fire No. 1 cylinder and with vacuum control in position to connect vacuum pipe. See Figures 10-35 or 36. Install distributor clamp and bolt with lockwasher, leaving bolt just loose enough to permit movement of distributor with heavy hand pressure. NOTE: If distributor does not seat in engine block, press down lightly on distributor while cranking engine with starter. After distributor tang snaps into slot in oil pump shaft, start timing again from step 1, leaving distributor installed.

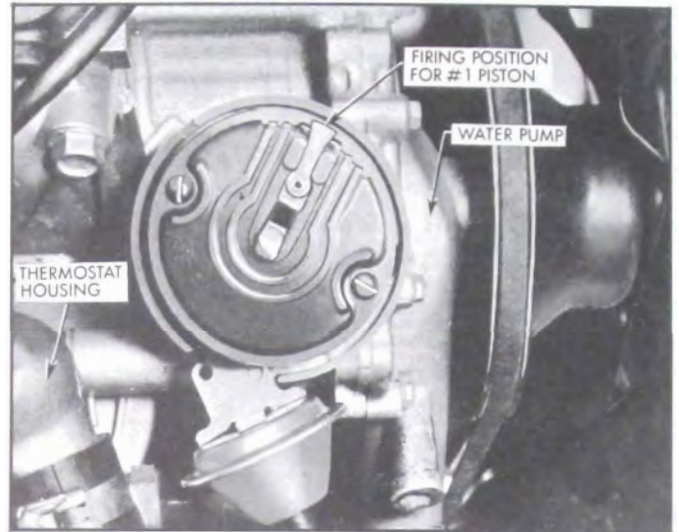

Figure 10-35—Installing Distributor in Engine (V-8)

3. Connect pipe to vacuum control and connect primary wire to coil.

4. Rotate distributor counter-clockwise slightly until contact points just start to open.

**CAUTION:** This must be done very carefully or engine will not start.

5. Install distributor cap. Make sure that spark plug wires are correctly installed in distributor cap, through clips on rocker arm covers, and on spark plugs. See Figures 10-37 or 38.

#### **b. Finish Timing (Engine Running)**

This method of timing with the centrifugal spark advance in operation is designed to eliminate the variation (in different distributors) in the RPM at which centrifugal spark advance starts. See Figure 10-31 or 32.

1. Disconnect vacuum hose from distributor.

2. Connect a dwell-tach unit between distributor terminal of coil and ground.

3. Connect a timing light at No. 1 spark plug (left bank).

4. Start engine and set dwell angle at 30 degrees, using an extended tool such as Adjusting Tool J-6788.

5. Set engine speed at exactly 1050 RPM, so that centrifugal advance mechanism is in operation.

6. Set timing at 7.5 degrees (midway between the 5 and 10 degree marks on timing indicator).



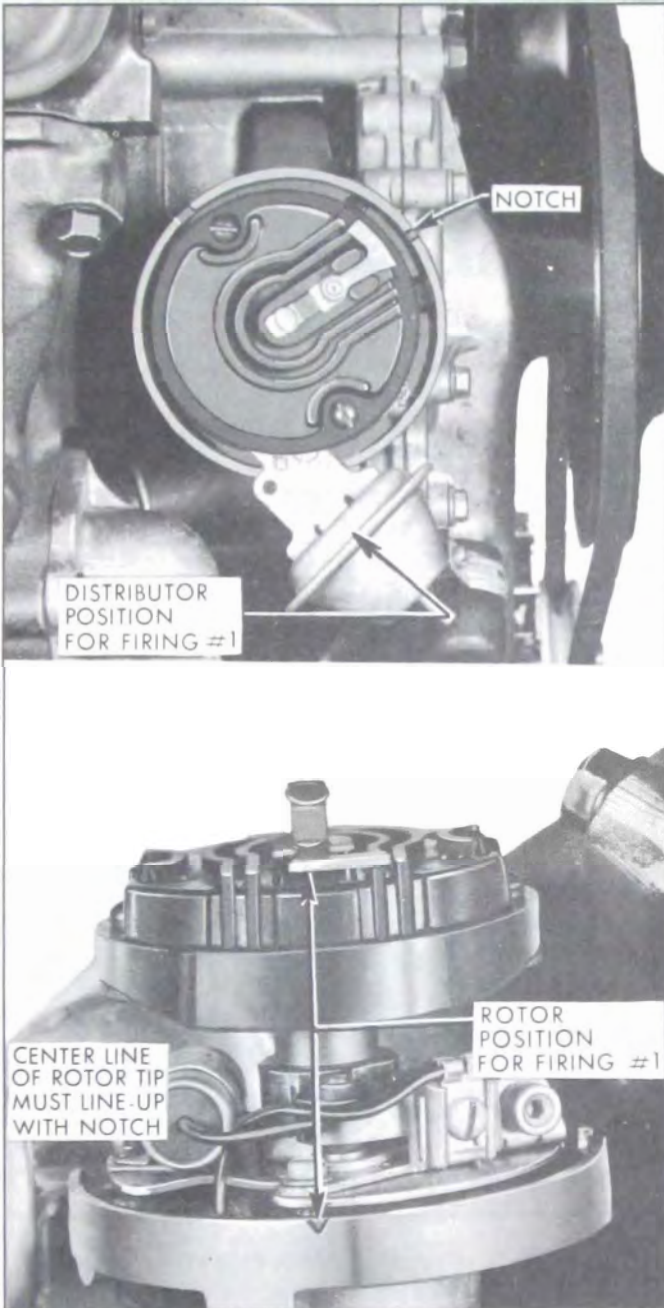

Figure 10-36—Installing Distributor in Engine (V-6)

On cars having hi performance engines and automatic transmissions, set timing at 10 degrees.

7. Tighten distributor clamp bolt securely using a 9/16 inch flexible socket. Recheck timing.

8. Set idle speed at 525 RPM (air conditioner car, 575 RPM). Stop engine and remove test equipment.

9. Reconnect vacuum hose to distributor.

If, for any reason, it is not possible to time

engine using the above procedure the conventional (but less accurate) method may be used. Use same procedure as in steps 1 - 9 above, except set timing at 5 degrees with engine idling slowly at approximately 400 RPM. (Hi performance automatic transmission engines should be timed at 7-1/2 degrees if timed at idle.) This slow idle is to make sure that the distributor advance has not started.

### 10-36 SPARK PLUG AND WIRE SERVICE

#### a. Remove and Inspect Spark Plugs and Wires

1. To disconnect wires, pull only on boot because pulling on wire might cause separation of the core of the wire. Remove spark plugs and gaskets using a 13/16" deep socket wrench. Use care in this operation to avoid cracking spark plug insulators.

2. Carefully inspect the insulators and electrodes of all spark plugs. Replace any spark plug which has a cracked or broken insulator, or which has loose electrodes. If the insulator is worn away around the center electrode, or the electrodes are burned or worn, the spark plug is worn out and should be discarded. Spark plugs which are in good condition except for carbon or oxide deposits should be thoroughly cleaned and adjusted.

3. The spark plug wires are of a special resistance type. The core is carbon-impregnated linen. This wire is designed to eliminate radio and television interference radiation, but is also superior in resistance to cross-fire. The resistance type wire, however, is more easily damaged than copper core wire. For this reason care must be taken that the spark plug wires are removed by pulling on the spark plug boots rather than on the wire insulation. Also, when it is necessary to replace a spark plug boot, the old boot should be carefully cut from the wire and a small amount of silicone lubricant used to aid in installing the new boot. If the wire is stretched, the core may be broken with no evidence of damage on the outer insulation. The terminal may also pull off the wire. If the core is broken, it will cause missing. In the case of wire damage, it is necessary to replace the complete wire assembly as a satisfactory repair cannot be made.

4. Wipe ignition wires with cloth moistened

with kerosene, and wipe dry. Bend wires to check for brittle, cracked, or loose insulation. Defective insulation will permit missing or cross-firing of engine, therefore defective wires should be replaced.

5. If the wires are in good condition, clean any terminals that are corroded and replace any terminals that are broken or distorted. Replace any broken or deteriorated cable nipples or spark plug boots.

### b. Spark Plug Cleaning

Spark plugs which have carbon or oxide deposits should be cleaned in a blast type spark plug cleaner. Scraping with a pointed tool will not properly remove the deposits and may damage the insulator. If spark plugs have a wet or oily deposit dip them in a degreasing solvent and then dry thoroughly with dry compressed air. Oily plugs will cause the cleaning compound to pack in the shell.

Carefully follow the instructions of the manufacturer of the cleaner being used, cleaning each plug until the interior of shell and the entire insulator are clean; however, avoid excessive blasting.

Examine interior of plug in good light. Remove any cleaning compound with compressed air. If traces of carbon or oxide remain in plug, finish the cleaning with a light blasting operation. Clean firing surfaces of center and side electrodes with several strokes of fine sandpaper.

When spark plugs have been thoroughly cleaned, carefully inspect for cracks or other defects which may not have been visible before cleaning.

### c. Adjusting Spark Plug Gap

Use round wire feeler gauges to check the gap between spark plug electrodes. Flat feeler gauges will not give a correct measurement if the electrodes are worn. Adjust gap by bending the side electrodes only; bending the center electrode will crack the insulator. Adjust gaps to .035". Setting spark plug gap to any other specification to improve idle or effect other changes in engine performance is not recommended.

### d. Installation of Spark Plugs

Use AC type 45FFS spark plugs with 3/8"

long terminal nuts for regular compression V-8 engines operated under average conditions. For regular V-8 engines operated mainly at high speeds, the colder AC type 44FFS spark plugs are recommended. For hi performance V-8 engines, use AC type 44FFS spark plugs. For V-6 engines, use AC type 44S spark plugs.

When installing spark plugs, make sure that gaskets are in good condition to insure a tight seal and also make sure that all surfaces on plugs and in cylinder heads are clean. Lubricate threads in spark plug holes with light engine oil. Install spark plugs by hand, then tighten to 20 ft. lbs. torque, using a 13/16" deep socket, an extension and a torque wrench. CAUTION: To avoid stripping spark plug threads in aluminum heads, these instructions on lubrication and torquing of spark plugs must be followed in all cases.



Figure 10-37—Installing Spark Plug Wires in Cap (V-8 Engine)

### e. Installation of Spark Plug Wires

Spark plug wires must be arranged to pass through the wire clips on the rocker arm covers in the same order as they are attached to the spark plugs. If spark plug wires are not correctly installed, missing or cross-firing may result. For instance, No. 5 and 7 cylinders may cross-fire (since they fire consecutively) unless the rubber grommet is inserted in the clip so that No. 5 and 7 wires are separated.

No. 1 spark plug wire is installed in the first distributor cap tower after the adjusting window, moving in the direction of rotation. The other wires are then installed in a clockwise



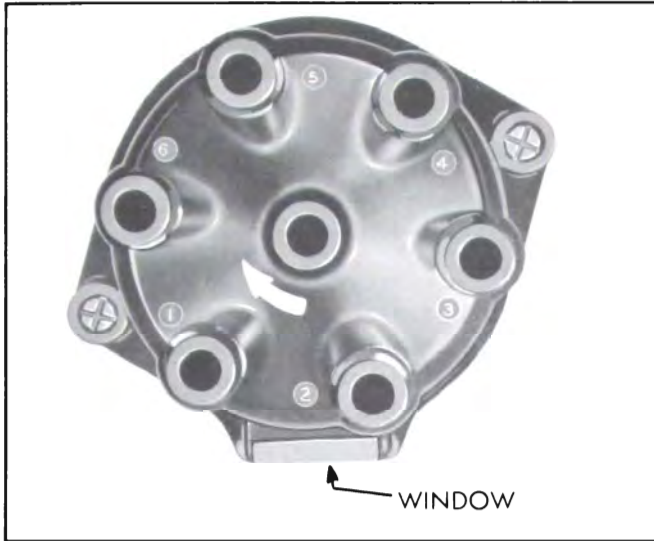

Figure 10-38—Installing Spark Plug Wires in Cap (V-6 Engine)

direction according to the firing order. See Figure 10-37 for V-8 engines or Figure 10-38 for V-6 engines.

## 10-37 IGNITION COIL TESTS

### a. Weak Coils

Most ignition coils that are replaced by service stations are classified by them as weak. Many coils rejected as weak actually test up to specifications and give normal performance.

A coil that actually is weak will first affect engine performance when the ignition reserve is at a minimum. This may be in starting, low speed acceleration or top speed. Eventually the engine will fail to start.

High resistance connections in either the primary or secondary circuit wiring will react the same as a weak coil. Wide spark plug gaps, which require higher voltage than the coil can produce, put the coil under suspicion. High compression and lean carburetors increase the voltage requirements and lead to many needless coil changes. Leakage of high tension current through moisture on an unprotected coil terminal may produce carbon tracks which weaken the coil output voltage. For this reason the nipple on coil high tension terminal must be properly installed and in good condition.

When an ignition coil is suspected of being defective it should be tested as described below before being replaced.

### b. Testing Coil for Open and Grounded Circuits

Before using a coil test instrument, the coil should be tested for open and grounded circuits, using a 110-volt test lamp and test points.

1. Apply test points to both primary terminals of coil. If test lamp does not light, the primary circuit is open.

2. Apply one test point to the high tension terminal, and the other test point to one of the primary terminals. If secondary circuit is not open, the lamp will not light but tiny sparks will appear at test points when they are rubbed over terminals. If secondary circuit is open, no sparks will occur.

3. Apply one test point to a clean spot on the metal coil case and touch the other point to the primary and high tension terminals. If the lamp lights, or tiny sparks appear at the points of contact, the coil windings are grounded.

4. A coil with open or grounded windings must be replaced since internal repairs cannot be made. It is unnecessary to test such a coil with instruments. If windings are not open or grounded, a test for short circuits and other internal defects should be made with a reliable coil test instrument.

### c. Coil Test Instruments

Two general types of instruments are used in testing ignition coils. One type makes use of an open or protected spark gap, while the other reports the condition of the coil on a meter.

The spark gap type of tester should always be used comparatively, that is, the questionable coil should be compared with a coil of the same model that is known to be good. Both coils must be at the same temperature and identical test leads must be used. Certain variables caused by altitude, atmospheric or spark gap electrode conditions are usually present in the spark gap type of test.

The meter type testers are usually designed to permit testing the coil without making any connection to the secondary terminal. This eliminates the variables usually present in the spark type of test and avoids the necessity for comparison with a good coil.

Since different makes and models of coil



testers differ in their methods of use, as well as in the markings on meters, the instructions of the manufacturer must be carefully followed when using any coil tester. The instrument must be frequently checked to make certain that it is accurately calibrated.

Regardless of instrument or method used, the coil must be tested at normal operating temperature because internal defects often fail to show up on a cold test.

## 10-38 DISTRIBUTOR CONDENSER TESTS

When a condenser is suspected of being faulty it should be tested with a reliable condenser tester to determine whether it is actually the cause of ignition trouble. The condenser should be tested for (a) high series resistance (b) insufficient or excessive capacity (c) low insulation resistance.

A special condenser tester is required to make these tests. When using a condenser tester the instructions of the manufacturer must be carefully followed. **IMPORTANT:** The condenser must be at normal operating temperature when it is being tested.

### a. High Series Resistance

High series resistance in the condenser causes condenser to be slow in taking the charge and, consequently, a higher than normal voltage is developed across the contact points when they first start to open. This higher voltage causes more disturbance at the contact points, which in turn causes more rapid wear and more tendency toward oxidized surfaces. The condition can become severe enough to cause complete failure of the ignition system. It would first show up during starting and low speed operation.

High series resistance may be caused by internal resistance in condenser or by resistance in the connections. Any defect caused by internal resistance should show up at low mileage since this does not change very much with time or use. The damaging changes are in the connections, in which looseness, corrosion, or broken strands may develop.

New condensers may have a series resistance as low as .05 ohm. Some condenser testers are set to reject condensers which have

a resistance of .3 ohm; however, tests show that the resistance can go to .5 ohm before ignition performance is affected.

### b. Insufficient or Excessive Capacity

The condenser specified for use in the Buick ignition system has a capacity of .18 to .23 microfarads.

If a condenser is used which does not have the specified capacity of .18 to .23 microfarads, excessive pitting or one contact point and a corresponding build-up of metal on the other contact point will result. A condenser having insufficient capacity will cause build-up of metal on the breaker arm (positive) point. A condenser having excessive capacity will cause build-up of metal on the contact support (negative) point.

In exceptional cases, pitting and metal build-up on contact points may be experienced even when condenser capacity is within the specified limits. In such cases the life of contact points will be improved by installing a condenser of high-limit capacity if metal build-up is on breaker arm point, or a condenser of low-limit capacity if metal build-up is on contact support point. There is usually sufficient variation in the capacities of stock condensers to permit selection of a high or low limit condenser by testing the available stock.

### c. Low Insulation Resistance

A weak or leaking condenser is usually one that has absorbed water so that the insulation resistance of the winding is lowered to the extent that the condenser will not hold a charge satisfactorily. A condenser with low insulation resistance will drain sufficient energy from the ignition system to lower the secondary voltage seriously. The condenser specified for use in the Buick ignition system is sealed to prevent absorption of water, and no other type should be used.

A leaky condenser usually does not affect engine performance except when hot. It is unlikely that a condenser with low insulation resistance would cause missing at low or medium speeds under conditions where the condenser does not get hot. A condenser that has low enough resistance to affect engine performance when cold would probably be indicated as broken down on most condenser testers.

Condenser testers equipped to check conden-

sers for low insulation resistance usually give a reading in megohms, a megohm being one million ohms. The scale is marked to indicate whether the condenser is good or bad.

When testing a condenser for low insulation resistance the lead should always be disconnected from the distributor. Since the distributor terminals and the connected circuit have much lower insulation resistance than the condenser, failure to disconnect the condenser lead will give a reading much to low.

## 10-39 DISTRIBUTOR SERVICE OPERATIONS

### a. Removal and Disassembly of Distributor for Inspection

1. Disconnect the distributor primary wire from coil and disconnect hose from vacuum unit. Remove distributor cap by inserting a screwdriver in upper slotted end of cap latches; then press down and turn 90° counter clockwise.

2. Make a mark on distributor base in line with center of rotor. Then carefully note the direction the vacuum unit points in relation to engine so that the distributor can be replaced in the exact same position after it is serviced. See Figure 10-35 or 36. CAUTION: If engine is turned over while distributor is out, complete ignition timing procedure must be followed (par. 10-35).

3. Remove distributor clamp and lift distributor out of timing chain cover.

4. Remove rotor from end of distributor shaft by removing two attaching screws and lock washers.

5. Remove contact point set and condenser as described in paragraph 10-40.

6. Remove two screws holding vacuum advance unit to housing. Remove advance unit.

7. Remove O-ring seal from shaft housing.

### b. Inspection of Distributor Parts

1. Wash the distributor assembly in clean solvent, holding housing horizontal to avoid getting cleaning solvent into the lubricant reservoir. Dry parts thoroughly.

2. Cap. Wipe out distributor cap with a clean cloth and inspect it for chips, cracks, and carbonized paths which would allow high-tension leakage to ground. Such defects require replacement of cap. Clean loose corrosion from surfaces of terminal segments inside the cap. Do not use emery cloth or sand paper. If segments are deeply grooved, the cap should be replaced. Pull cables from terminal sockets and inspect sockets for corrosion. Clean sockets, using a stiff wire brush to loosen corrosion.

3. Rotor. If rotor is cracked, spring contact is badly worn, or rotor tip is badly burned, rotor must be replaced. See Figure 10-39.

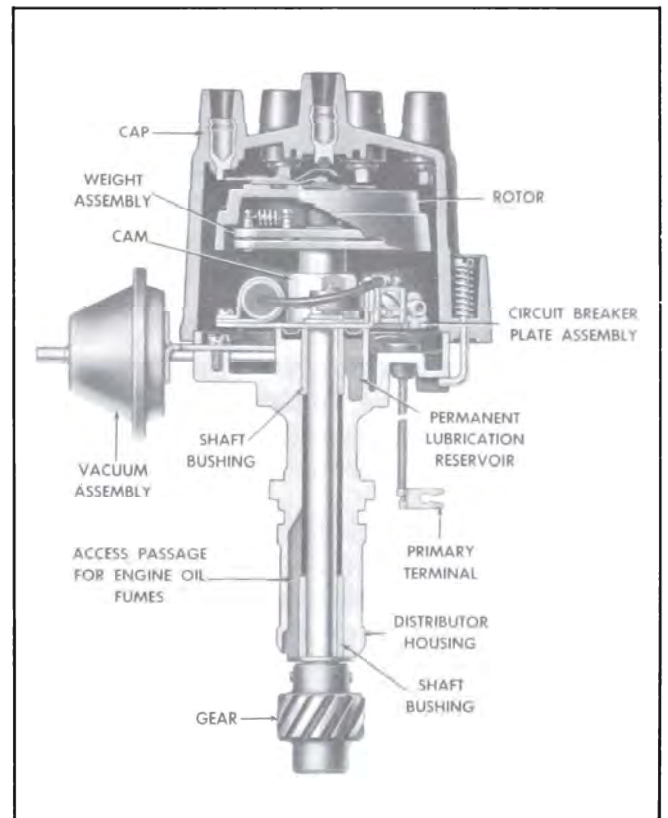

Figure 10-39—Distributor, Sectional View

4. Condenser. Inspect condenser and primary leads for loose or frayed terminal connections. Check condenser in a reliable condenser tester as described in paragraph 10-21.

5. Vacuum Advance Unit. Inspect rod end for excessive wear. Push rod into unit as far as possible, hold finger tightly over nipple, and then release rod. After about 15 seconds, release finger from hole and notice if air is

drawn in. If not, diaphragm is leaking and unit must be replaced.

6. Contact Points. Carefully examine the mating surfaces of the contact points, noting whether they are flat and making good contact, or whether they are blackened, pitted, burned, or worn excessively. Contact points which have been in service for some time will appear dull and gray. This condition is normal and such points should not be replaced.

Contact points which are blackened or only slightly burned or pitted may be cleaned with a thin contact stone or a clean fine-cut contact file. Remove high points only; it is not necessary to remove all buildup or pit. **CAUTION:** Do not use emery cloth or sandpaper to clean contact points because particles of these materials usually embed in contact surfaces and cause points to burn.

Excessive burned, pitted or worn contact points cannot be cleaned up and aligned satisfactorily; therefore, they must be replaced to insure satisfactory ignition (par. 10-34).

If contact points are excessively burned, pitted, or blackened it is advisable to check for cause and make the necessary correction so that new points will give satisfactory service. Burned or pitted points may be caused by:

(a) Ignition coil resistance unit not properly connected into circuit. Connect between ignition switch and coil positive (+) terminal.

(b) Defective condenser. Test the condenser (par. 10-38).

(c) Insufficient contact point opening. Adjust contact point dwell as described in paragraph 10-34.

(d) Oil vapors getting into the distributor and depositing on contact surfaces of points. This causes arcing and rapid burning of contact points. Oil vapor entering distributor usually produces a smudgy line under the points.

(e) High voltage, or any other condition in electrical system causing excessive flow through contact points. This results in a blue scale forming on point surfaces. Check condenser for high series resistance (par. 10-38). Check voltage and current regulator (par. 10-21).

(f) Radio capacitor connected to distributor terminal. This will cause excessive pitting of

contact points. Capacitor should be connected to the positive (battery) terminal of coil.

7. If any remaining parts are defective, the distributor must be completely disassembled to replace them. Before disassembling distributor further, inspect parts as follows:

(a) Centrifugal Advance. Inspect for excessive wear between centrifugal weights and advance cam, or pivot pins. Turn weight base plate in a clockwise direction until weights are fully extended, then release and allow springs to return weights to retard position. Repeat several times. Springs should return weights to stop without sticking and there should be no excess free movement in the retard position.

(b) Cam and Weight Base Plate. Inspect cam lobes for scoring or excessive wear. Check weight base plate for bind or excessive looseness on distributor shaft.

(c) Breaker Plate. Attempt to rotate plate to check for excess free motion between plate and vacuum advance unit linkage. Check plate for excessive looseness on O.D. of upper distributor shaft bushing. Check breaker plate ground lead for poor spot-weld at plate end or for loose or frayed terminal connections.

(d) Distributor Shaft. Check for excessive wear between shaft and bushings in housing.

(e) Driven Gear. Inspect gear for scoring of teeth or excessive wear.

8. To replace any part found to be defective in step 7, the distributor must be completely disassembled as follows:

(a) Drive spring pin through driven gear and shaft using a 1/8" straight punch. See Figure 10-40. **CAUTION:** Be careful not to bend distributor shaft or damage gear when driving pin out.

(b) slide gear off shaft and then pull the shaft, breaker cam, and centrifugal advance mechanism from the housing.

(c) Remove two advance weight springs and weights. Slide the integral weight base plate and breaker cam off the lower end of shaft.

(d) Remove retainer from upper bushing and lift breaker plate and felt washer from upper bushing. **NOTE:** Lubricant reservoir contains sufficient lubrication for the life of the distributor. Never remove plastic reservoir cover or degrease bore of housing.

(e) Remove distributor primary lead and



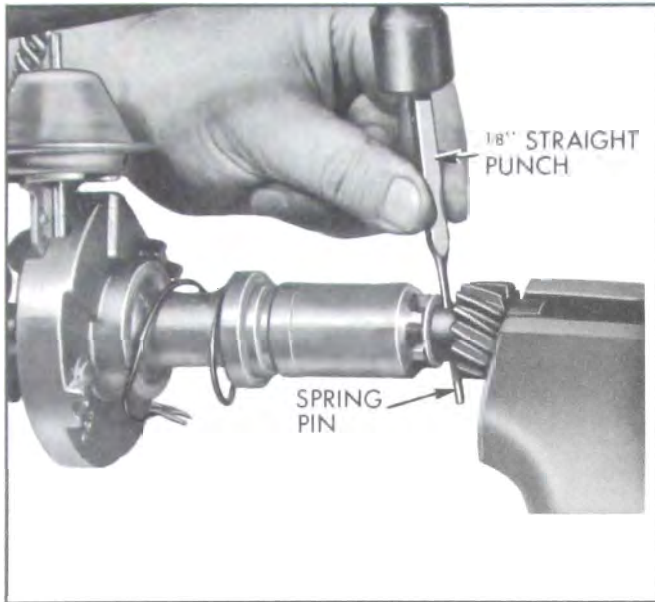

Figure 10-40—Removing Distributor Gear Pin

grommet from housing. **NOTE:** No attempt should be made to replace the shaft bushings in the housing as the housing and bushings are only serviced as an assembly.

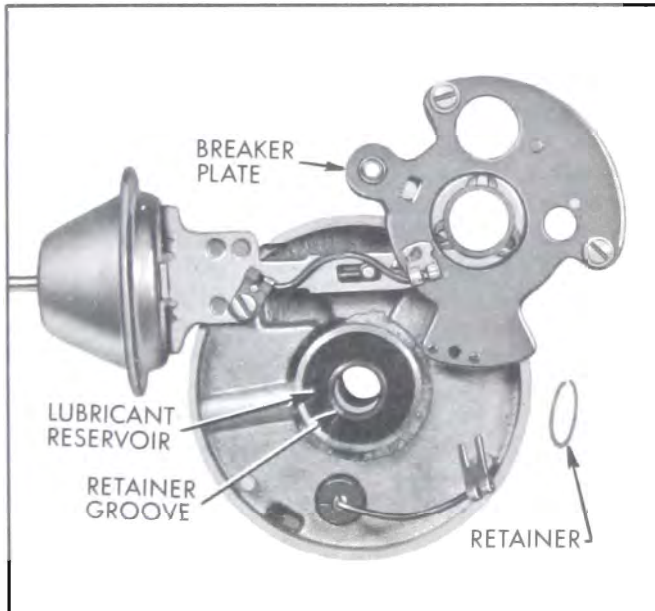

Figure 10-41—Installing Breaker Plate and Retainer

### c. Assembly and Installation of Distributor

**NOTE:** The first five steps apply only if the distributor has been completely disassembled.

1. Install distributor primary lead and rubber grommet. Install vacuum advance unit with ground lead terminal from breaker plate under

outer mounting screw.

2. Install felt washer over upper bushing and apply a few drops of light oil. Then place breaker plate over upper bushing and vacuum advance link. Install retainer on upper bushing. See Figure 10-41.

3. Slide distributor cam and weight base plate on distributor shaft.

4. Install distributor shaft and breaker cam assembly in housing. Install advance weights and springs.

5. Slide driven gear on shaft. Install spring pin. Be careful not to damage gear.

6. Place condenser and bracket over bosses on breaker plate and secure with screw.

7. Place contact point set over boss on breaker plate and secure with two screws and lock washers. Apply one drop of light oil to breaker arm pivot. Then install condenser and primary leads.

8. Work a small amount of high temperature cam and ball bearing lubricant (available through U.M.S.) into a clean cloth, then hold cloth against distributor cam while turning distributor shaft. **CAUTION:** Excessive grease may throw off into contact points when hot.

Petroleum jelly is not suitable for temperature reached by the cam.

9. Make the preliminary contact point adjustment (par. 10-34, b).

10. Install rotor and secure with two screws, lockwashers, and plain washers.

**NOTE:** The square and round lugs on the bottom of the rotor must be positioned in the corresponding holes in the weight base plate.

11. If a reliable distributor tester is available, check the distributor to make certain that the centrifugal and vacuum advance mechanisms are operating according to the specifications given in paragraph 10-4 (c). **NOTE:** Mount distributor in tester with all end-play of the distributor shaft in the up position; this is to eliminate any possible drag between the centrifugal advance cam and weight base plate.

12. Install new O-ring seal on distributor housing.

13. Insert distributor in engine block so that rotor is pointing to mark made on distributor base, with vacuum advance unit pointing in exact original direction.

14. Install distributor clamp and bolt with lockwasher, leaving bolt just loose enough to permit movement of the distributor with heavy hand pressure.

15. Connect primary wire to distributor side of coil. Install distributor cap.

16. If spark wires were removed, make certain that they are arranged as shown in Figure 37 or 38. Wires must be pushed all the way down into the distributor cap terminals and onto the spark plugs. Nipples must be pushed firmly over the terminals and boots over the spark plugs.

17. Start engine and adjust contact point dwell angle (par. 10-34, c). Then adjust ignition timing (par. 10-35, b). NOTE: If engine was accidentally turned over while distributor was out, complete ignition timing procedure must be followed (par. 10-35, a & b).

## 10-40 IGNITION SWITCH AND LOCK REPAIRS

### a. Ignition Switch Key

If ignition key sticks or feels rough as it is inserted into the lock, examine it for burrs and smooth up with a fine cut file. Blow finely powdered graphite into lock cylinder, then work key in and out of cylinder a number of times to work graphite into tumblers. Do not use oil in lock cylinder as this will cause tumblers to stick.

If ignition switch key is lost and key code number is not known, the code number will be found stamped on the glove box lock cylinder, which must be removed. A new key can be cut by using this code number.

### b. Lock Cylinder Replacement

To remove lock cylinder, insert key and turn ignition switch to "ACC" position. Insert a stiff wire (paper clip) in small hole in face of cylinder to depress the pin which locks the cylinder, turn cylinder counter-clockwise and pull out. To install lock cylinder insert key, place cylinder in switch slightly counter-clockwise from "ACC" position, press inward and turn cylinder clockwise. See Figure 10-42.

### c. Ignition Switch Replacement

1. Disconnect battery ground cable to avoid a possible short circuit.



Figure 10-42—Ignition Switch

2. Unplug connector from switch.

3. Remove lock cylinder (subpar. b).

4. Remove ignition switch escutcheon using Wrench J-8562. Remove ignition switch. See Figure 10-64.

5. Install new switch by reversing above procedure.

### d. Removal of Lock Cylinder Which Cannot be Unlocked with Key

When ignition switch fails to unlock with the proper key, and lock has previously been operating satisfactorily, the lock cylinder can be removed as follows:

1. Draw a centerline on cylinder at 90° to left side of key slot, insert key, and make a prick punch mark on centerline 3/8" from side of key. Carefully drill a .0465 hole (No. 56 drill) through cylinder flange at this point.

2. File the end of a stiff wire (paper clip) to a taper. Insert this end of wire in drilled hole to pry the cage bar assembly down so that lock cylinder can be turned. After turning cylinder slightly, remove the wire to avoid wedging, then remove lock cylinder in the regular manner (subpar. b, above).

3. Stake cage bar in place at four points. Staking must not distort cage. Reinstall lock cylinder and check operation with key. If operation is satisfactory, plug the drilled hole with a small pin No. 00 x 1/8" (Parker Kalon type "U").