

## SECTION 10-G SIGNAL SYSTEMS

### CONTENTS OF SECTION 10-G

Paragraph	Subject	Page	Paragraph	Subject	Page
10-45	Horns and Control Circuit . .	10-62	10-47	Direction Signal Lamps and Switch . . . . .	10-65
10-46	Trouble Diagnosis and Adjustment of Horns . . . .	10-62			

### 10-45 HORNS AND CONTROL CIRCUIT

#### a. Horns and Relay

Two Delco-Remy electrically operated vibrator type horns are mounted in the engine compartment on the right and left wheelhouse. Both horns are operated simultaneously by a horn relay which is controlled by the horn push button on steering wheel. The left horn is high pitched and the right horn is low pitched, so that together they produce a pleasant blended tone.

The horn relay is an electrical switch which closes the circuit between the battery and the horns when the push button is pressed and opens the circuit when the button is released. The relay permits control of the horns with a small amount of current passing through the horn button contacts. The high current required by the horns would cause arcing and burning of these contacts.

When the horn button contacts are closed, a small amount of current flows through the relay winding to ground at the horn push button contact. This magnetizes the relay core which attracts the flat steel relay armature. The armature has a contact point which makes contact with a stationary point to close the horn circuit. When horn push button is released, current stops flowing through relay winding so that the core loses its magnetism; the armature spring then causes contact points to be separated.

#### b. Horn Relay Ground Circuit

The standard steering wheel has a cap at hub of wheel with a push button mounted in its center. See Figure 10-53. This push button operates the same as the two that are used with

the deluxe steering wheel which is described below.

The deluxe steering wheel has an actuator bar mounted across the steering wheel. Fastened to the base of the actuator bar, but insulated from it, is a contact plate which is "hot" at all times. See Figure 10-54. When the actuator bar is rocked, the contact plate contacts a ground plate on the steel hub of the steering wheel to ground the horn relay winding, close the relay contacts, and blow the horn. When the actuator bar is released, two springs move the actuator bar and contact plate assembly clear of the ground plate.

Current is supplied to the contact plate by a spring-loaded brush which rides on the contact ring located at the upper end of the steering column. See Figure 10-53. A wire attached to the contact ring runs down inside the steering column jacket and out under the instrument panel. The wire from the horn relay connects at this point.

### 10-46 TROUBLE DIAGNOSIS AND ADJUSTMENT OF HORNS

If a horn button contact is constantly grounded, the horn will not stop blowing or if a contact cannot be grounded, the horns will not blow.

There are two basic troubles which may be caused by a defective horn relay. If neither horn will blow at all, this trouble may be caused by the relay points not making contact. Or if horns will not stop blowing, this trouble may be caused by relay points sticking.

#### a. Horns Will Not Blow

When horns fail to blow, first check wiring

circuit and relay because even a faulty horn will generally make some sort of noise if current is getting to it. If horns are at fault, or tone is poor, adjust each horn for specified current draw as instructed in subparagraph e.

1. Break circuit at connector for horn wire that enters steering mast jacket (tan wire) and ground wire from horn relay. If horn now blows, horn relay ground circuit in mast jacket or steering wheel has an open. Reconnect wire on connector and check horn wire and horn contacts. Circuit from connector at mast jacket to contact on steering wheel must be complete. To remove horn contact, proceed as follows:

(a) Standard Steering Wheel. Loosen one screw retaining cap assembly. Disconnect horn contact wire from connector brush wire. Remove two screws retaining horn contact in cap. See Figure 10-53.

(b) Deluxe Steering Wheel. Remove two retaining screws from actuator bar cap. Remove four clutch-head retaining screws from actuator bar. Remove four plastic retaining rivets from con-

tact plate. See Figure 10-54.

2. To remove horn connector brush, proceed as follows:

(a) Standard Steering Wheel. Remove cap assembly. Remove steering wheel. Remove staking from underside with a chisel and remove horn connector brush. See Figure 10-55.

(b) Deluxe Steering Wheel. Remove actuator bar cap. Remove actuator bar. Lift ground plate and horn connector brush from steering wheel.

3. If horns still do not blow when wire at mast jacket is grounded, unplug double connector from horn relay part of junction block assembly which is mounted on right wheelhouse. See Figure 10-56. Then plug a known good relay and junction block assembly onto the connector and press battery terminal of new assembly against old junction block battery terminal stud for a source of current. Have helper try blowing horns. If horns blow, original relay is defective and must be replaced.

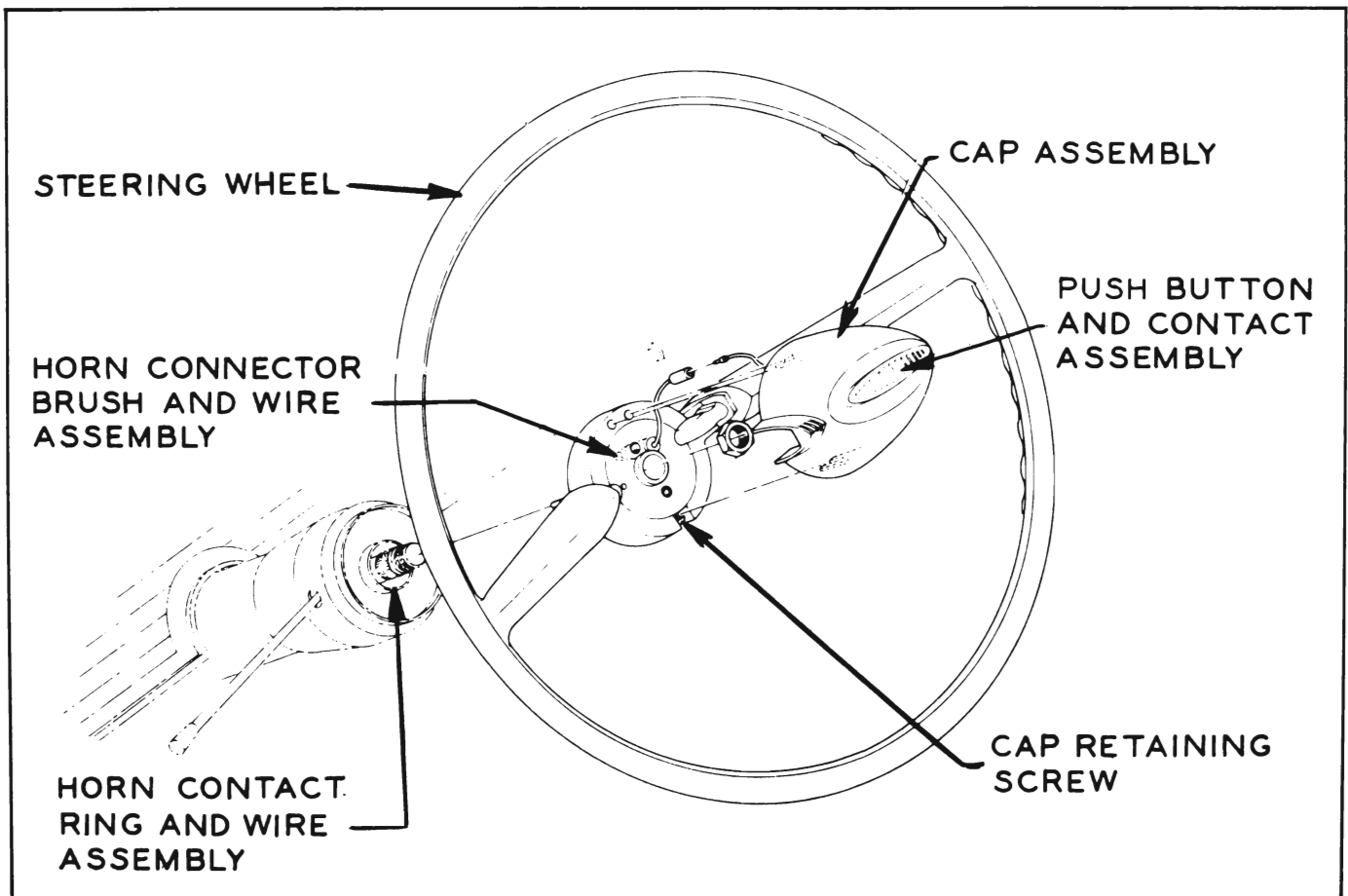

Figure 10-53—Standard Steering Wheel!

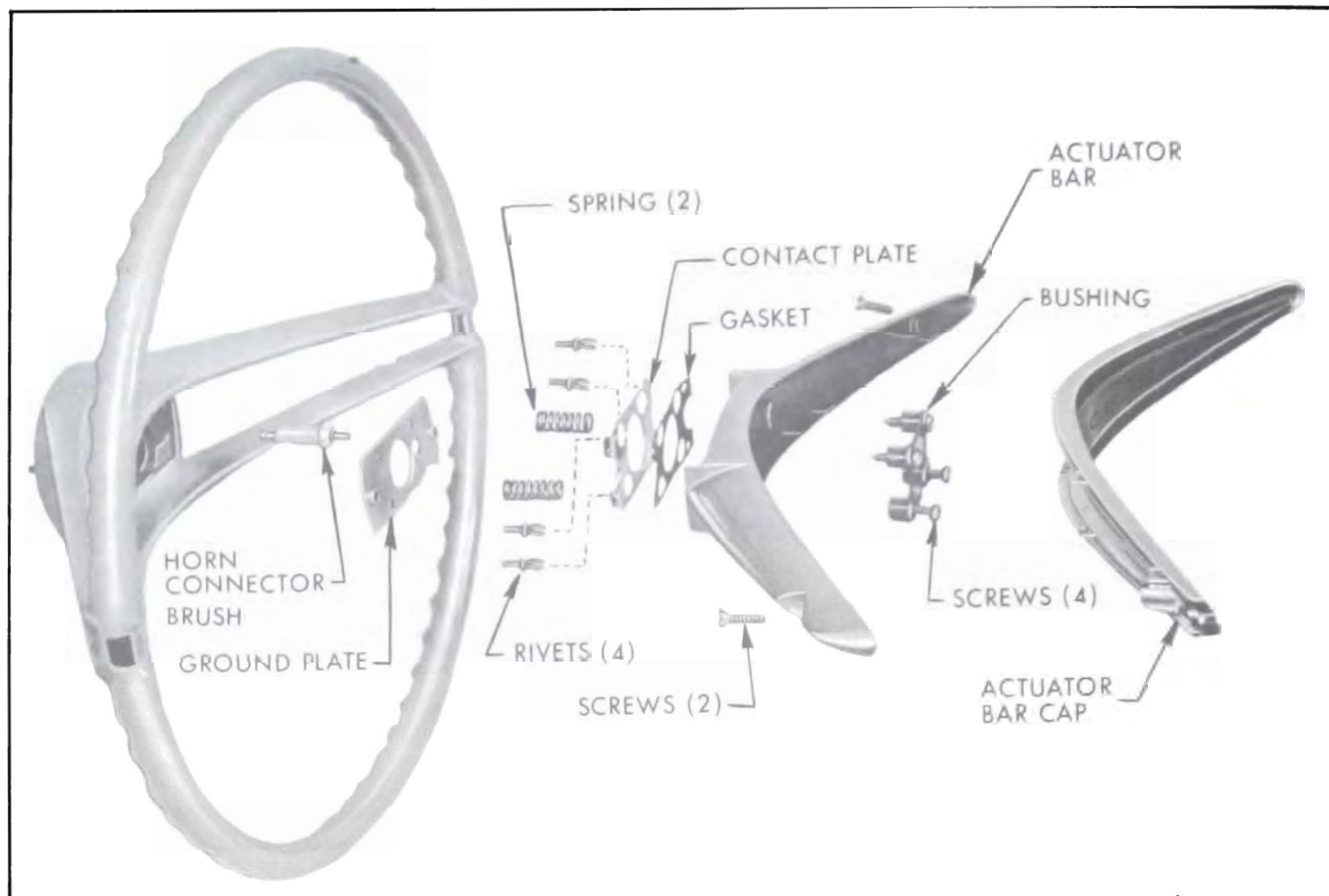

Figure 10-54—Deluxe Steering Wheel

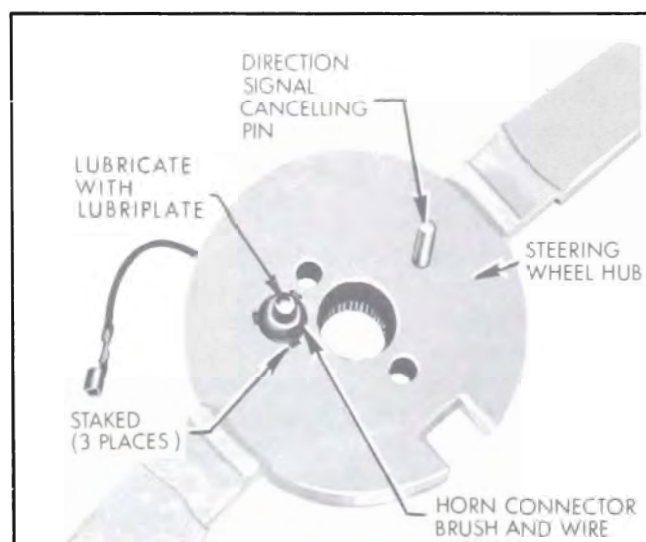

Figure 10-55—Horn Connector Brush - Standard Steering Wheel

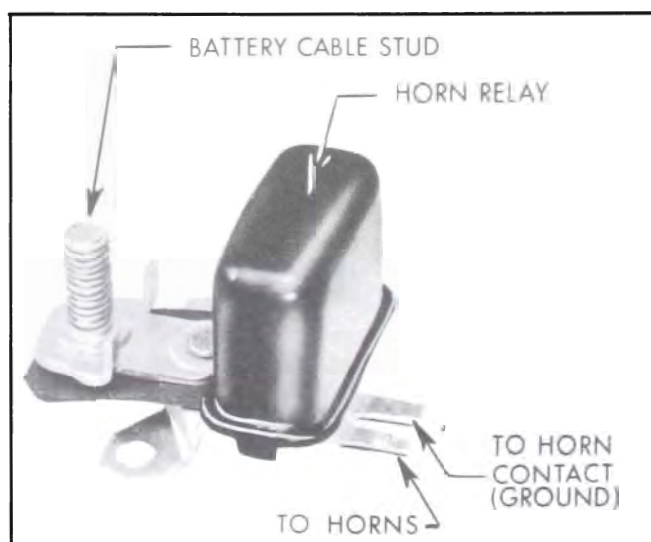

Figure 10-56—Horn Relay and Junction Block Assembly

4. If horns still will not blow with substitute horn relay trouble is elsewhere. Check wiring connections and wiring throughout horn circuit. See Figure 10-102 for wiring diagram.

#### b. Horns Will Not Stop Blowing

1. Pull horn wire from connector on wire that enters mast jacket (tan wire). If horns stop blowing, relay is OK, but horn control circuit

in jacket is grounded. If horns do not stop blowing, horn relay control circuit is grounded. Check horn wire and contacts in mast jacket and steering wheel if horns stopped blowing.

2. If horns still do not stop blowing, unplug double connector from horn relay. Then plug a known good relay onto the connector and make contact with junction block stud.

3. If horns now stop blowing, original relay contacts are sticking and relay and junction block assembly must be replaced. However, if horns still do not stop blowing, control circuit is grounded between relay and connector on wire that enters jacket.

### c. Horn Tone is Poor

If either horn blows only part of the time or tone is poor, adjust current draw at horn, subparagraph e.

### d. Voltage Test at Horn

An improperly operating horn and its wiring circuit can be tested by connecting a voltmeter between the horn terminal and ground and noting the voltage while the horn button is pressed. The voltage at the horn gives an indication of the cause of trouble as follows:

1. No voltage indicates trouble in horn button, relay, wiring, or ground.

2. Less than 7 volts indicates trouble in wiring or excessive current draw due to short circuit in horn.

3. Voltage between 7 and 11 indicates that wiring is okay. Look for sticking or improper adjustment of horn.

4. Voltage above 11 indicates improper adjustment or open circuit in horn due to broken coil lead.

### e. Adjustment of Horns

1. Remove horn from car.

2. Connect an ammeter in series with horn and a fully charged 12 volt battery to measure current draw while horn is blowing. Current draw for each horn (either high or low note)

should be between 8 and 10 amperes at 12.0 volts.

3. Adjust to specified current draw if necessary, by turning adjusting screw clockwise to decrease or counter-clockwise to increase current draw. See Figure 10-57.

Increasing the current draw increases the horn volume. Too much current will cause a high cut-in voltage which will cause a sputtering sound and may cause horn to stick in cold weather.

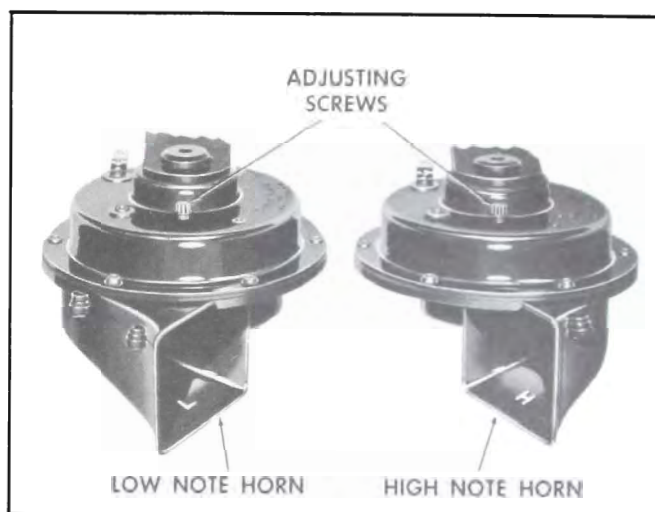

Figure 10-57—Matched Horn Set

4. After each horn has been adjusted individually, sound both horns together to check for proper blend of tone. If adjustment does not provide a satisfactory tone, horn contacts are pitted, making it necessary to replace horn.

5. With horns reinstalled on car, connect a volt-meter between each horn terminal and ground to check voltage while both horns are blowing. This should be between 7 and 11 volts.

## 10-47 DIRECTION SIGNAL LAMPS AND SWITCH

### a. Direction Signal Lamps and Indicators

The front direction signal light is produced by the 32 CP filament in the bulb mounted in the front parking lamp. The rear direction signal light is produced by the 32 CP filament in the bulb of the rear lamp assembly. This filament also serves as a stoplight.

When the ignition switch is turned on and the



direction signal switch is manually operated to indicate a turn, the front and rear signal lights flash on and off on the side of car for which a turn is indicated. The flashing of signal lights is caused by a flasher which is connected into the proper signal circuit by contacts made in the direction switch when switch is set for a turn.

When the direction signal lights are flashing, a signal indicator bulb on instrument panel also flashes, producing a green light to indicate the direction for which the signal has been set.

### b. Direction Signal Switch Operation

The direction signal switch is mounted on the steering mast jacket under the instrument panel. Its actuating mechanism is enclosed in a housing on the jacket just below the steering wheel. Movement of the actuating mechanism is transmitted to the signal switch through an actuating rod which runs down the inside of the jacket.

The upper end of the actuating rod is crank shaped and fits in a slot in the lever plate. See Figure 10-58. The lower end of rod is attached to the signal switch by a spring pin which is installed around switch operating pin and through hole in rod. An anti rattle spring located on rod between spring pin and the positioning tab which is part of mast jacket, holds the rod in place. See Figure 10-54.

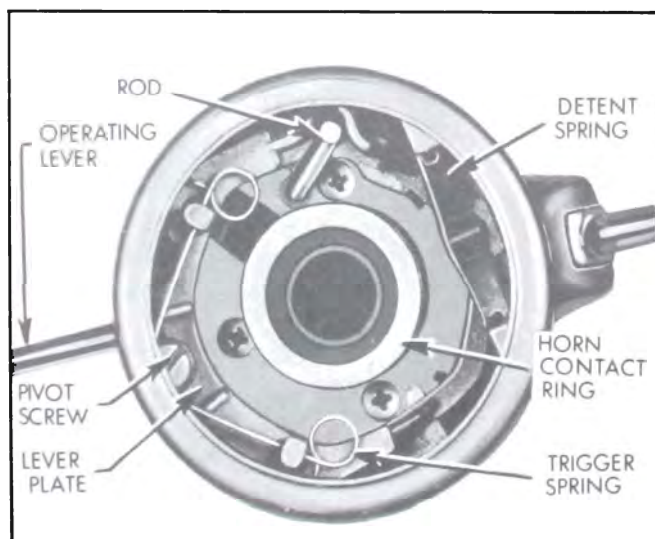

Figure 10-58—Top View of Direction Signal Switch Actuator

The turn signal control lever is threaded into the lever plate. When the lever is moved up or down, it causes the lever plate to rotate

around a pivot screw and in turn the actuating rod is rotated. A detent spring mounted in the housing bears against a nylon roller mounted on the lever plate to hold the plate in whatever position it is set. Bosses in the housing provide stops for the plate when set for either turn.

The movement of the rod and switch actuator are not adjustable, therefore, any adjustment must be made by moving the switch on the steering mast jacket. See subparagraph d for the adjustment procedure.

The trip or cancellation mechanism for returning the switch to the "off" position after a turn is completed consists of a trigger spring on the lever plate and a switch cancelling pin on the steering wheel hub. See Figure 10-58. The pin extends down through the lever plate, but when the switch is in the "off" position the lever plate is centered so that the pin cannot contact the trigger spring as the steering wheel is turned.

When the control lever is moved clockwise to set the switch for a right turn the lever plate is moved down bringing the upper loop of the trigger spring into the path of the cancelling pin. As the steering wheel is turned right and the cancelling pin contacts the trigger spring the spring yields to permit the pin to pass without interference. As the wheel is turned left at completion of the right turn, the cancelling pin pushes the loop of trigger spring against a stop on the lever plate, and this forces the lever plate and switch back to the "off" position.

A similar action but in the opposite direction takes place when the switch is set for a left turn. If the switch is erroneously set to indicate a turn in one direction and the turn is made in the opposite direction, the cancelling pin will contact the trigger spring and return the switch to the "off" position as the wrong turn is started.

### c. Trouble-Shooting Direction Signal System

When a front or rear signal bulb is burned-out, the indicator light for that direction will flash very rapidly. This immediately notifies driver when any signal light quits operating.

1. No Signal Anywhere. If there is no signal at any front, rear, or indicator light, first check fuse on fuse block marked "DIR. SIG."

Since this fuse also protects the stop light system, functioning stop lights indicate that fuse is OK.

If fuse checks OK, next eliminate flasher unit by substituting a known good flasher. If new flasher does not cure trouble, check signal system wiring connections at fuse block and at signal switch.

Also check to see if the spring pin that retains actuating rod to switch pin is properly installed or broken. See Figure 10-59.

**2. Signals One Direction Only.** If signal works properly on one side, but there is no signal at front, rear, or indicator light on other side, adjust direction signal switch. See subparagraph d below. If trouble cannot be corrected by adjustment, replace switch.

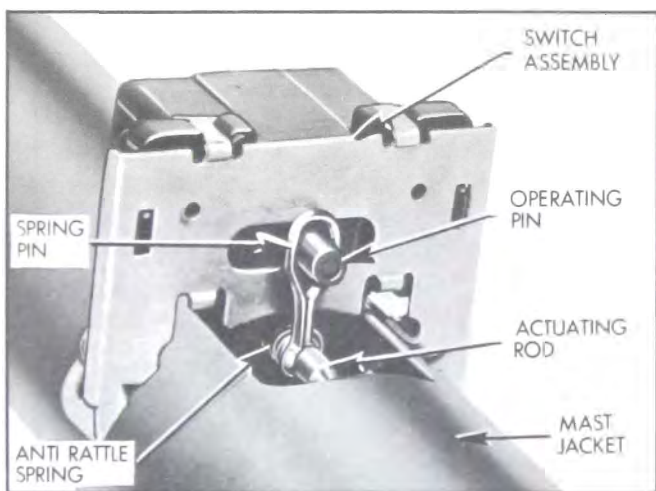

Figure 10-59—Direction Signal Switch Installation - Bottom View

**3. Signal Too Rapid One Direction.** If there is an abnormally rapid signal at one light and other light does not light, check for a burned-out light bulb or an open circuit in wire to bulb not lighting.

**NOTE:** If brake stop lights function properly, rear signal light bulbs are OK.

**4. Fails to Cancel After Completion of Turn.** If signal lights do not turn off after completion of turn, check for worn or broken switch actuator parts or for broken cancelling pin on

steering wheel hub.

**NOTE:** It is necessary to removing steering wheel to service switch actuator parts.

#### d. Direction Signal Switch Adjustment

Whenever a direction signal switch is installed, it must be properly adjusted. Incorrect adjustment of the switch is indicated if the direction signal system operates in one direction only.

The directional signal switch is mounted on the mast jacket under the instrument panel. It is actuated by a rod from the actuator assembly on the upper end of the mast jacket. The movement of the rod is not adjustable, therefore any adjustment necessary must be made by moving the switch on the jacket.

Adjust direction signal switch as follows:

1. Place direction signal control lever in center position. (Switch actuator has center detent.)

2. Loosen two switch mounting screws and move switch sideways on mast jacket until pin projecting from switch is centered. See Figure 10-59. Tighten switch mounting screws.

3. To recheck adjustment, turn on ignition switch, place turn signal control lever in each position, and check all signal lights.

#### e. Direction Signal Lamp Circuits

Since the direction signal lights are independent of the headlamp lighting switch and thermo circuit breaker, the wiring circuits are protected by a "DIR. SIG." fuse on the fuse block under the cowl. The flasher is also mounted on the fuse block, which serves as a terminal block between the signal switch and the chassis wiring.

Figure 10-60. shows the directional signal circuits when signal switch is set for No Turn, Right Turn, and Left Turn. Direction signal switch wiring is also shown in the wiring circuit diagram, Figure 10-102.

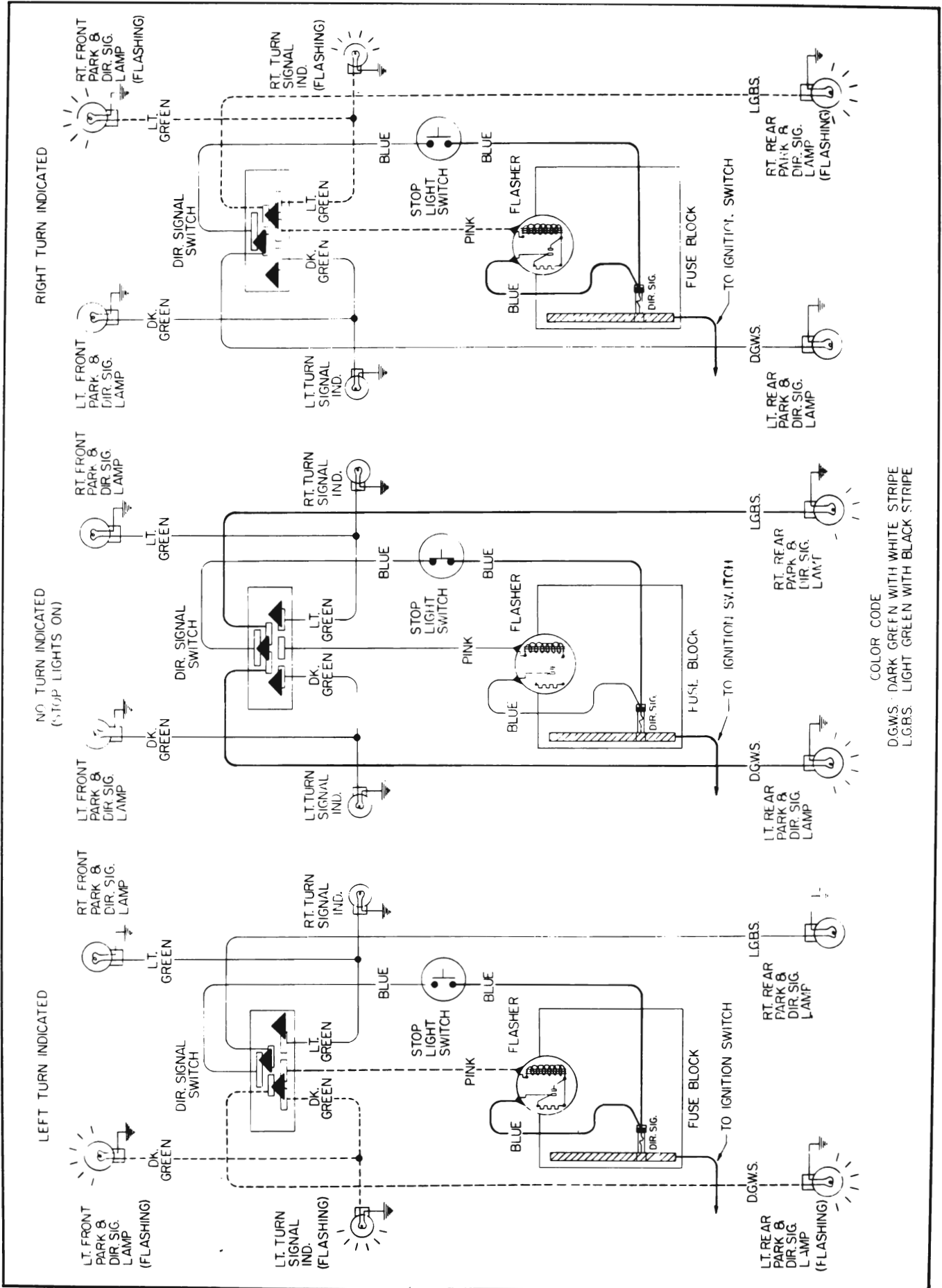

Figure 10-60—Direction Signal Lamp Circuit Diagram