

SECTION 10-F LIGHTING SYSTEM

CONTENTS OF SECTION 10-F

Paragraph	Subject	Page	Paragraph	Subject	Page
10-41	Headlights and Controls	10-45	10-43	Parking, Tail, Stop, License and Back-Up Lights	10-48
10-42	Headlamp Sealed Beam Unit Replacement and Adjustment	10-46	10-44	Interior Lights and Cigar Lighter	10-54

10-41 HEADLIGHTS AND CONTROLS

a. Description of Lighting Switch

The switch uses a multiple push-on type connector. The switch is a "push-pull" type which also incorporates a manually operated rheostat for controlling the instrument panel lights, and a detent position which completes the dome light circuit. Three "push-pull" positions of the switch knob provide control of the exterior lights as follows:

1. Off position (knob all the way in) cuts off all lights controlled by the switch.
2. Parking position (knob pulled out to first notch) turns on the parking lights, tail lights, and license light. The instrument panel lights also will be turned on if the rheostat is set for these lights.
3. Driving position (knob pulled out to last notch) turns parking lights off and turns headlights on, while the other lights remain as in the parking position. The headlights will be on the upper or lower beams depending on the position of the separate dimmer switch.

In the parking and driving positions, the instrument panel lights are controlled by rotating the light switch knob. With the knob turned counterclockwise, these lights are on maximum brightness. As the knob is turned clockwise, they

gradually dim until they are off at the full clockwise position of the knob.

4. Dome light position (knob turned fully counterclockwise) turns the dome light on. The dome light can be turned on regardless of the in-or-out position of the switch.

b. Description of Thermo Circuit Breaker

A thermo circuit breaker is incorporated in the lighting switch assembly, to protect wiring from damage due to short circuits in the headlight and front parking light circuits only.

The thermo circuit breaker consists of a bi-metal blade and set of contact points connected in series with the lighting circuits. An abnormal flow of current through the circuit breaker, such as would be caused by a short circuit in a lighting circuit, heats the bi-metal blade sufficiently to separate the points and cause them to vibrate. The vibrating blade alternately opens and closes the circuit thus reducing the flow of current and protecting the wiring against overheating and burning. The flickering light produced by the vibrating circuit breaker serves as a warning to the operator of vehicle that a short circuit exists.

c. Test of Lighting Switch

If the lighting switch is suspected of being faulty, the contacts can

be tested by connecting a low reading voltmeter between the wire supplying current to the contact and the wire conducting current away. This must be done with the switch in a position where the contact under test is closed. See Figures 10-43 and 10-115.

1. To check the switch contact for the headlights, pull switch knob out to last notch and also make sure dimmer switch is in upper beam position. Connect voltmeter prods between battery and headlight terminals of switch (between red and yellow wires). If voltage loss through switch contacts is over .2 volt, switch must be replaced.
2. To check the contact for the tail lights, connect voltmeter between tail lights and tail light fuse terminals (between gray and black wires). If voltage loss is over .1 volt, switch must be replaced.
3. To check the contact for the parking lights, put switch knob in first notch position. Connect voltmeter between battery and parking light terminals (between red and white-black stripe wires). If voltage loss is over .1 volt, switch must be replaced.

d. Replacement of Lighting Switch

1. Disconnect battery ground cable to avoid a possible short circuit.

2. Unplug multiple connector from lighting switch.

3. Pull switch knob out to last notch, then depress the spring loaded latch button on left side of switch, while pulling knob and rod assembly out of switch.

NOTE: If latch button is depressed before switch knob is pulled out, knob and rod assembly will not release.

4. Remove switch escutcheon using Wrench J-8563 and remove switch from instrument panel. See Figure 10-78.

5. Install switch in reverse order of above steps, making sure that switch alignment tang lines up with slot in instrument cluster before tightening mounting nut.

e. Test of Thermo Circuit Breaker

To test the thermo circuit breaker, remove lighting switch from instrument cluster to avoid possible damage to adjacent instruments.

Since the current required to open the circuit breaker contacts depends somewhat on outside temperature, the circuit breaker should be tested at normal temperature (70° to 80°F.).

1. Connect an ammeter and a carbon-pile rheostat in series with the battery terminal of lighting switch and positive terminal of a 12-volt battery, and set rheostat to provide maximum resistance. Rheostat must have capacity for 50 amperes and be adjustable down to .3 ohms.

2. With switch on, connect the headlight terminal of lighting switch and the negative post of battery. See Figure 10-53.

3. Adjust rheostat to give 26 amperes. The circuit breaker should open within 60 seconds.

4. Adjust rheostat to give 15 amperes on ammeter. The circuit

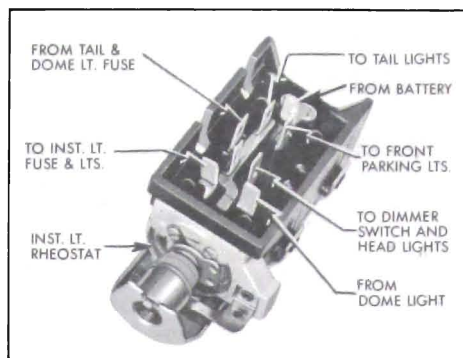

Figure 10-53—Light Switch

breaker should remain closed indefinitely at 15 amperes.

5. If circuit breaker does not operate as specified the lighting switch assembly must be replaced since internal repairs cannot be made.

f. Dual Headlamp Assembly

A dual headlamp system is standard equipment on all series and consists of two dual headlamp assemblies, one mounted on each side of the car.

Each dual headlamp includes two 5 3/4" T-3 sealed beam units mounted in a single housing enclosed by one headlamp door. The inboard unit is used for bright lights only and has a single filament. The outboard unit is used for both bright and dim lights and has two filaments. For identification, the inboard unit is marked "1," the outboard unit is marked "2".

When the dimmer switch is in the dim or lower beam position only, the outboard unit of each dual headlamp is on. Both outboard and inboard units of each dual headlamp are on when the dimmer switch is in the bright or high beam position.

The T-3 sealed beam unit has three projections equally spaced around the perimeter of the lens. These projections are ground off at the factory to provide a mounting surface for aiming devices.

These aiming devices are used without having headlights on as described below.

g. Dimmer Switch

The driver may select the upper or lower headlight beam as traffic and road conditions demand by operating the dimmer switch mounted on the toe panel in a convenient position for the left foot.

The dimmer switch opens and closes the circuits to the upper and lower lamp filaments in the sealed beam units, thereby alternately raising and lowering the headlight beams with each successive operation of the switch. Depression of switch button turns the rotary contacts one position within the switch. The spring-loaded button automatically returns to the reset position when released.

The wiring connection to the dimmer switch is made by a multiple connector. The dimmer switch is mounted on the inner side of the toe pan, so the switch, connector and wiring are all inside the car.

h. Headlight Beam Indicator

Whenever the upper headlight beams are lighted, a beam indicator bulb in the instrument cluster also lights, producing a small spot of red light in front of the driver. See Figure 10-73. For safety reasons, never pass an approaching car with the beam indicator showing red.

10-42 HEADLAMP SEALED BEAM UNIT REPLACEMENT AND ADJUSTMENT

a. Replacement of Sealed Beam Unit

1. Raise hood and pull the wiring connector from the sealed beam unit.

2. Remove headlamp door by removing retaining screws.

3. Unhook the spring from retaining ring, then remove sealed beam unit and retaining ring assembly, being careful not to disturb the two beam adjusting screws.

4. Remove two screws fastening retaining ring to mounting ring. Remove retaining ring and sealed beam unit.

5. Install new sealed beam unit by reversing removal procedure. Position lens with the "1" or "2" up. The reflector has three lugs which fit into notches in the headlamp mounting ring.

CAUTION: Make sure that sealed beam unit is marked "1" for an inboard unit or "2" for an outboard unit.

6. Before installation of headlamp door, adjust headlamp for proper aim as described below.

b. Headlamp Aiming

The headlamps must be properly aimed in order to obtain the maximum road illumination and safety that has been built into the headlighting equipment. With the Guide T-3 type sealed beam units, proper aiming is even more important because the increased range and power of this lamp make even slight variations from recommended aiming hazardous to approaching motorists. The headlamps must be checked for proper aim whenever a sealed beam unit is replaced and after any adjustment or repairs of the front end sheet metal assembly.

Regardless of method used for checking headlamp aim, car must be at curb weight, that is, with gas, oil, water, and spare tire, but no passengers. Tires must be uniformly inflated to specified

pressure (par. 1-1). If car will regularly carry an unusual load in rear compartment, or a trailer, these loads should be on car when headlamps are checked. Some states have special requirements for headlamp aiming adjustment and these requirements should be known and observed.

Horizontal and vertical aiming of each sealed beam unit is provided by two adjusting screws which move the mounting ring in the body against the tension of the coil spring. There is no adjustment for focus since the sealed beam unit is set for proper focus during manufacturing assembly.

c. Mounting Headlamp Aimer

NOTE: It is not necessary to remove headlamp doors to check headlamp aim.

1. Drive the car onto the selected aiming area.

2. Remove the headlamp doors and replace any defective unit.

IMPORTANT: For an accurate headlamp aim the floor must either be level or else the T-3 Safety Aimer must be calibrated for the selected aiming area in accordance with instructions received with aimer. Once the aimer is calibrated for an unlevel floor, all future aimings MUST be made with cars placed on the same area faced in the same direction.

3. Mount the T-3 Aimers on each of the inboard units (type "1") so that the lamp guide points engage smooth inner ring of aimer and the arm on each aimer points toward center of car.

4. Secure Aimer to each headlamp unit by pressing plunger knob firmly. See Figure 10-55. Rotate arm to approximately horizontal position.

5. With aimers in place, position the knots on each end of the elastic string in the slots provided on both aimers. See Figure 10-56. Car doors must be closed and car rocked gently sideways to equalize springs, prior to checking and adjusting headlamps.

6. Rotate aimers around headlamp units so that the scale on each aimer just clears the string.

NOTE: For aiming both inboard (type "1") and outboard (type "2") units, loosen level calibrating knob and slide knob rearward or forward until numeral "2" appears in DOWN view window. See Figure 10-54. Tighten knob of the aimer. All future checking and adjusting of headlamp aim will be done with aimer calibrated with numeral "2" in DOWN view window.

d. Checking and Adjusting Horizontal Aim

The string should cross between right and left line "2" on scale of aimer. If the string does not fall within these limits it is necessary to adjust horizontal aim by turning horizontal aiming screw on each unit until the string is positioned directly over the center line of the scale on the aimer. See Figure 10-57. Turn screw clockwise in making final adjustment to take up play in the headlamp mechanism.

e. Checking and Adjusting Vertical Aim

1. The bubble should be within the two outside lines of the level on the aimer. If bubble in level does not fall within these limits it is necessary to adjust vertical aim by turning vertical aiming screw counterclockwise until the bubble in level is at the end of vial toward headlamp unit. Then turn screw clockwise until bubble is centered in the level. See Figure 10-58.

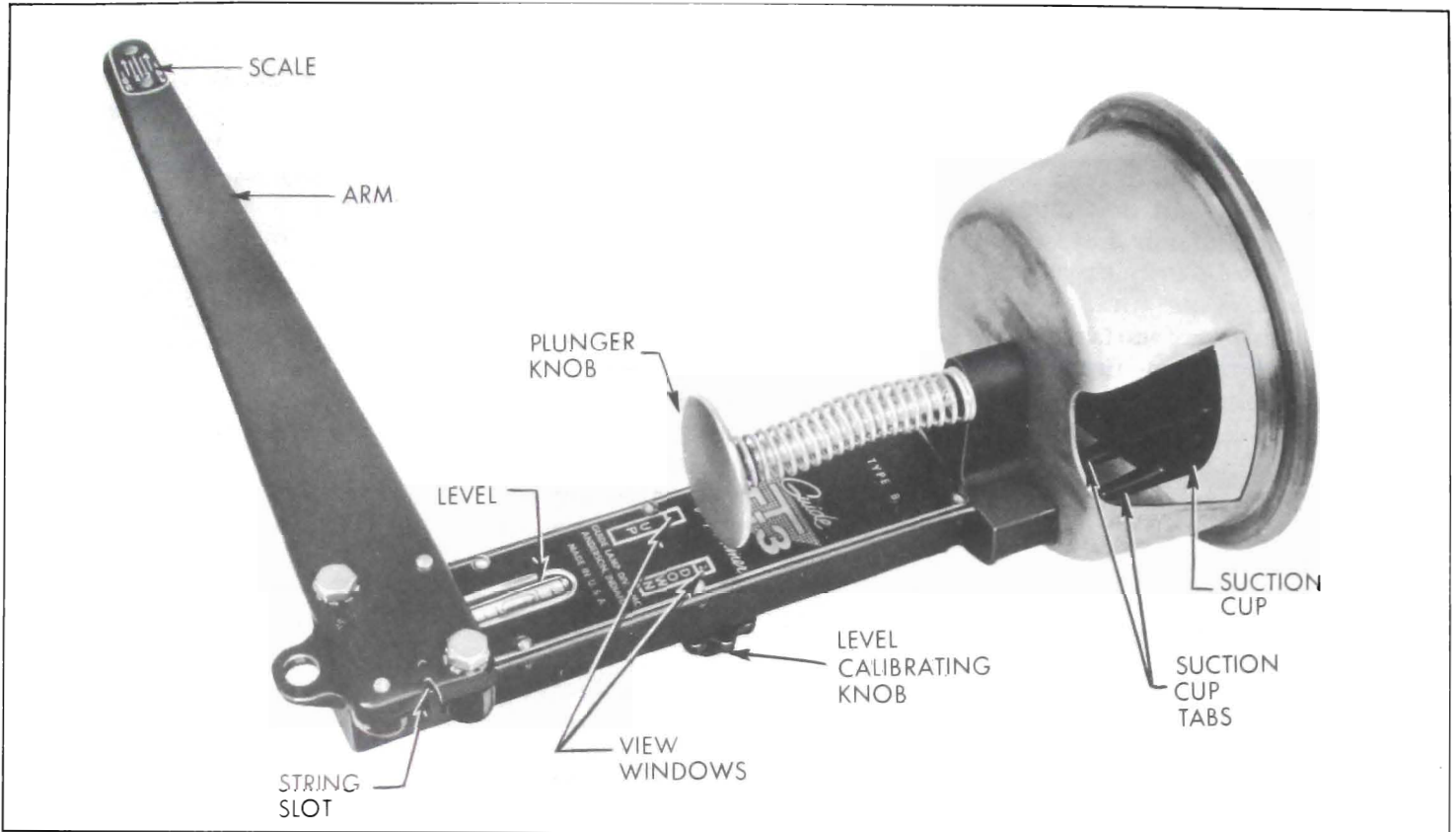

Figure 10-54—Left T-3 Aimer

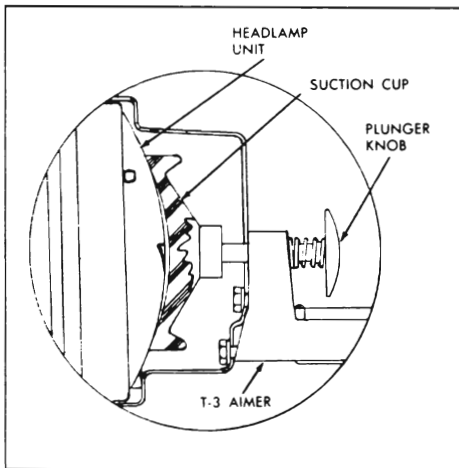

Figure 10-55—Attaching Aimer

2. Recheck the position of the string on the scale of the aimers, and the bubble in the levels.

3. Remove aimers by pulling on the suction cup tabs through opening in aimer. Mount the aimers on each of the outboard units and check and adjust aim of the type "2" units.

10-43 PARKING, TAIL, STOP, LICENSE AND BACK-UP LIGHTS

NOTE: See paragraph 10-5 for lamp bulb and fuse specifications.

a. Front Parking and Signal Lights

Each front parking and signal lamp contains one 32-4 CP lamp bulb which provides a 4 CP parking light and a separate 32 CP direction signal light. The pins on lamp bulb and slots in socket are offset to prevent improper installation of bulb in socket. The parking light is controlled by the lighting switch and the circuit is protected by the switch thermo circuit breaker. The direction signal light is separately controlled by the signal switch and the circuit is protected by the 20 ampere "DIR. SIG." fuse on the fuse block under the instrument panel. The lamp bulb is serviced

by removing the lens from the lamp body. Front turn signal lens are amber in color.

b. Tail, Stop, and Signal Lights

Each rear lamp assembly contains a 32-4 CP bulb which is used as a combination tail, stop, and direction signal light. The tail lights are controlled by the lighting switch and the circuit is protected by the 9 ampere "TAIL-DOME" fuse on the fuse block.

The stop lights are controlled by a hydraulic switch mounted on the master cylinder. The switch is closed by hydraulic pressure when the brakes are applied. The direction signal switch is in the circuit, so the stop lights may be flashing or constant depending on the position of the switch. The direction signal and stop light circuit is protected by the 10 ampere "DIR. SIG." fuse mounted on

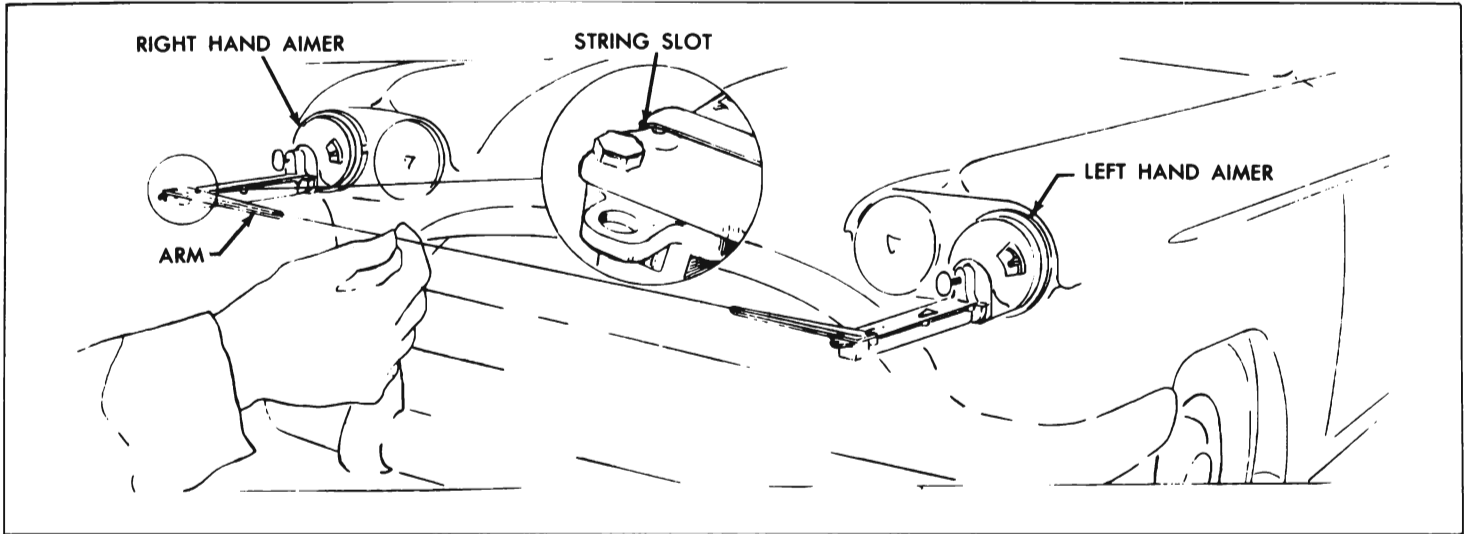

Figure 10-56—Positioning String

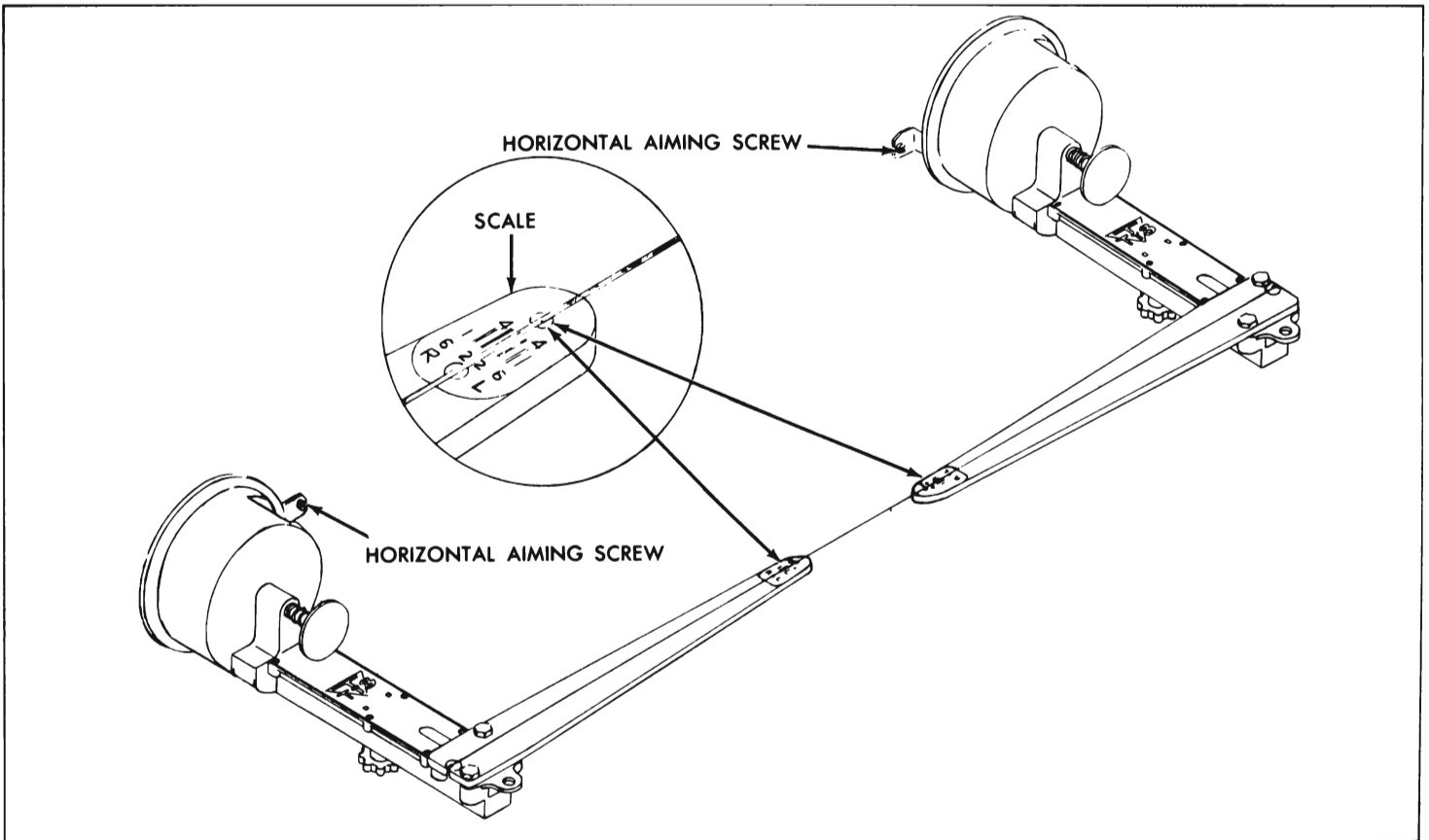

Figure 10-57—Adjusting Horizontal Aim

the fuse block under the instrument panel.

The combination tail, stop, and directional signal lamp bulb sockets can be snapped out from in-

side the trunk compartment on sedans. Since the position of the bulb filaments is important in the rear lamps, these sockets have been provided with a tongue and groove index to insure correct positioning. To change the bulb

on the station wagon it is necessary to remove the lens.

c. Replacement of Stop Light Switch

When replacing stop light switch

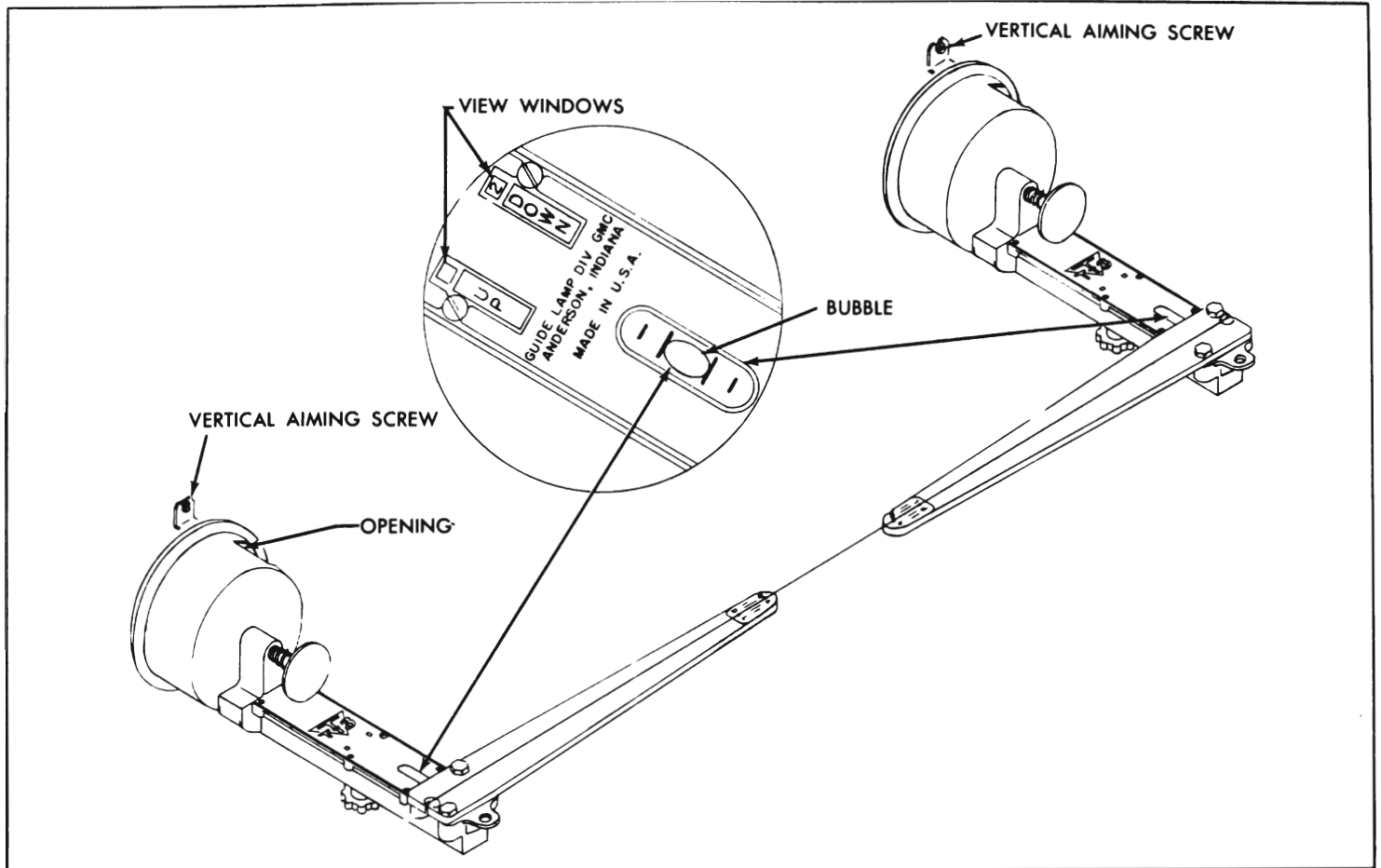

Figure 10-58—Adjusting Vertical Aim

have new switch ready to install as soon as old switch is removed from master cylinder to keep brake fluid loss to a minimum. Always fill master cylinder reservoir after new switch is installed. Make sure area around switch is thoroughly cleaned before making change.

d. Rear License Light

The rear license lamp is mounted above the license plate to provide adequate lighting of the plate. The lamp contains one 4 CP lamp bulb which operates in conjunction with the tail lights, and its circuit is also protected by the 9 ampere "TAIL-DOME" fuse on the fuse block.

e. Back-Up Lamps and Switch

Back-up lamps are optional on all

series and are located in the body rear end panel. Each lamp contains a 32 CP bulb behind clear plastic lens.

On synchromesh transmission cars, the back-up light switch is mounted on the steering mast jacket. This switch is actuated by a lever which projects through a slot in the jacket. The lever is attached to a weld nut on the transmission control shaft. See Figure 10-59. When the transmission is shifted into reverse, the control shaft is moved downward and then rotated counterclockwise. This in turn positions the lever so that it picks up the switch arm and turns the back-up lamps on. See Figure 10-60. When the shift is made out of reverse, the spring loaded switch arm returns to the off position. The back-up lights are turned on only

in reverse as the lever is not in position to pick up the switch arm when the shift is made to other gears. Figure 10-61 shows position of lever to switch arm when transmission is in second gear. A slotted switch mounting screw hole permits movement of the

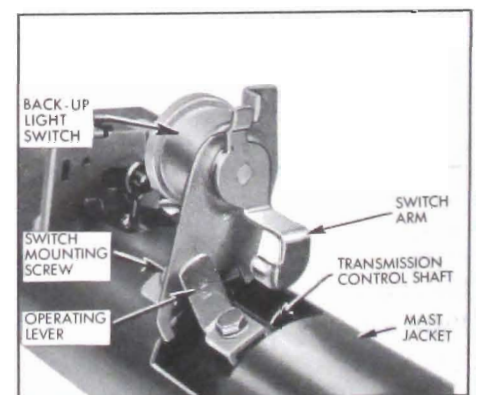

Figure 10-59—Bottom View of Back-up Light Switch - Neutral Position

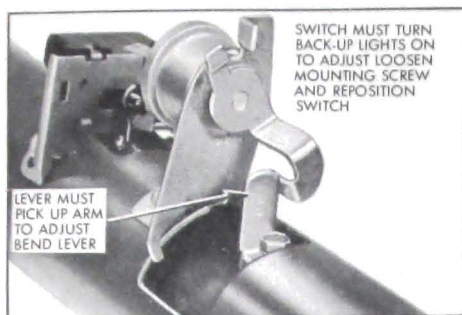

Figure 10-60—Back-up Light Switch - Reverse Gear

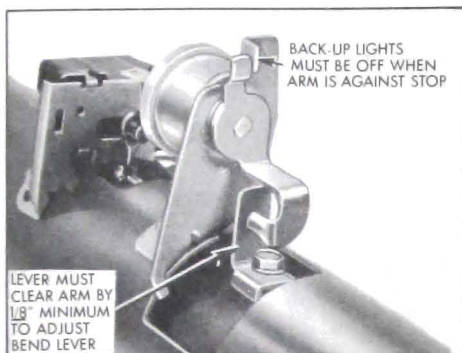

Figure 10-61—Back-up Light Switch - Second Gear

switch sideways on the mast jacket for proper locating. To adjust switch, proceed as follows:

1. Check synchromesh shift control linkage and adjust if necessary. (par. 4-11).
2. Turn ignition switch to "ON" position and check operation of switch. Back-up lights should be on only when transmission is in reverse gear.
3. If back-up lights are on in second gear, check position of operating lever to switch arm. There should be at least 1/8" clearance. If necessary bend lever. See Figure 10-61.
4. If back-up lights are on all the time, check to see if switch arm is against its stop when transmission is not in reverse. See Figure 10-61. If arm is against stop, try bending stop to reposition arm and turn lamps off.
5. If back-up lights are not on in

reverse, check to see that operating lever is picking up switch arm. If necessary bend lever. See Figure 10-60. If lamps are not on when switch arm is picked up correctly, loosen switch mounting screw and move switch on mast jacket until lamps are turned on. Retighten screw and recheck adjustment.

On 4-speed synchromesh transmission cars, the back-up light switch is mounted on the side cover of the transmission. See Figure 10-62. The switch is actuated by a small diameter rod connected to the reverse shift lever. Switch timing can be changed, if necessary, by bending the rod.

On automatic transmission cars, the back-up light switch is combined with the neutral safety switch. It is mounted on the mast jacket under the instrument panel. The switch is actuated by a lever on the transmission control shaft which projects through a slot in the jacket. When the neutral safety portion of the switch is correctly timed, the back-up portion is properly timed automatically. Slotted mounting screw holes permit sidewise movement of the switch for proper timing. See subparagraph f for the adjusting procedure for the neutral safety and back-up light switch. The back-up light circuit is protected by the 9 ampere "BACK-UP LTS" fuse on the fuse block.

f. Neutral Safety Switch Adjustment (All Automatic Transmission Cars)

Check and adjust neutral safety switch timing as follows:

1. Check shift control linkage and adjust if necessary (par. 5-12).
2. Place shift control lever in Neutral position.
3. Insert a 3/32" drill or a piece of 3/32" drill rod through gauging hole in operating lever and

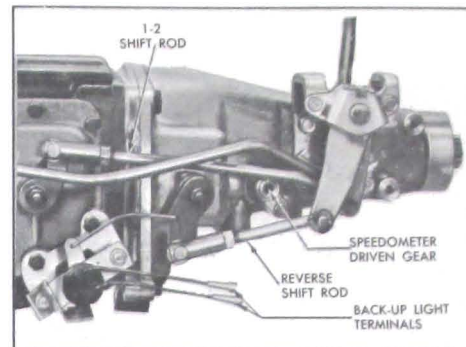

Figure 10-62—Back-up Light Switch - 4 Speed Transmission

through gauging hole in switch body.

CAUTION: Be careful not to cause shift control lever to move out of neutral position. See Figure 10-63.

4. If gauging drill or drill rod is now parallel with center line of steering column jacket, neutral safety switch timing is OK. If gauging drill will not go through holes or is not parallel, loosen two switch mounting screws and move switch sidewise until gauge is parallel. Then retighten screws.

5. To recheck adjustment, turn on ignition switch, place shift control lever in reverse, and make sure back-up lights are lit. Set parking brake, place shift lever in Neutral and make sure engine will start. Then place shift lever in Park and try starting engine again.

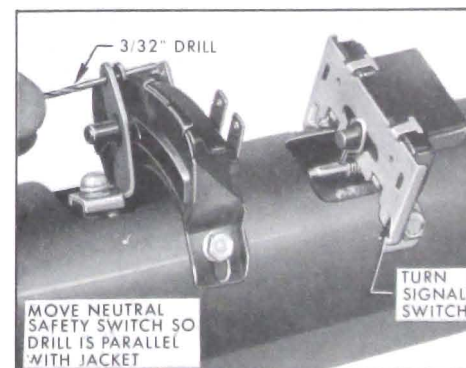

Figure 10-63—Checking Neutral Safety Switch Timing

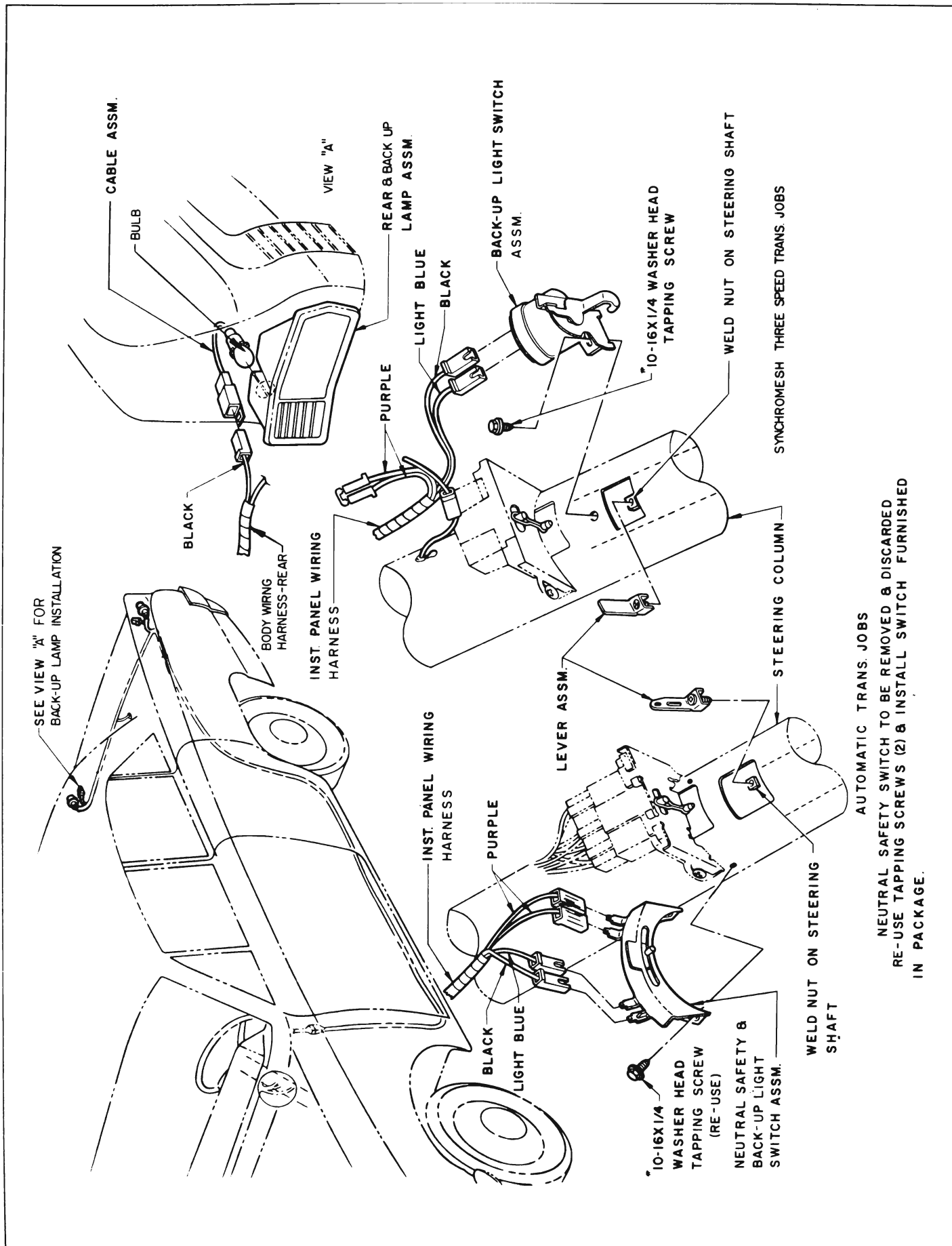

Figure 10-64—Back-Up Light Installation

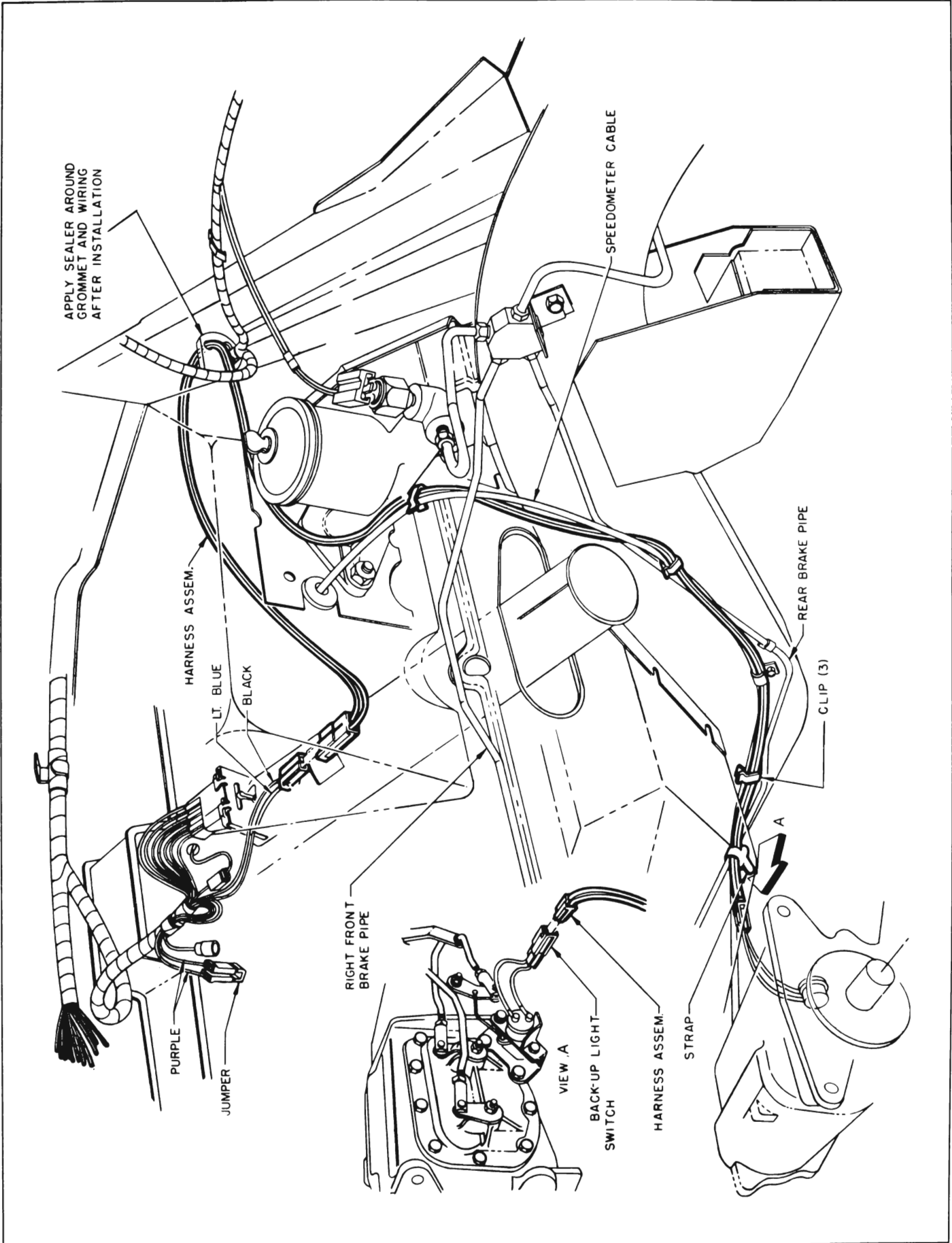

Figure 10-65—Back-Up Light Wiring - 4 Speed Transmission

10-44 INTERIOR LIGHTS AND CIGAR LIGHTER

NOTE: See paragraph 10-5 for lamp bulb and fuse specifications.

a. Instrument Panel Lights

The speedometer, heater-defroster controls and clock are illuminated by lamp bulbs mounted to provide indirect lighting.

The instrument panel lights are controlled by the lighting switch as described in paragraph 10-41 and the circuits are protected by the 3 ampere "PANEL" fuse on the fuse block.

To replace any of the instrument cluster light bulbs, remove the socket and bulb assembly from the instrument cluster by rotating counterclockwise. Replace the bulb and reinstall the assembly by

rotating it clockwise. See Figure 10-75 for the location of any instrument cluster bulb.

b. Direction Signal Indicator Lights

The direction signal indicator consists of a 2 CP bulb mounted at each end of the instrument cluster. See Figure 10-75 for the location of any indicator bulb socket.

c. Cigar Lighter

The cigar lighter is heated by pressing the knob in until it latches; the knob will automatically unlatch and return to "off" position when heated to proper temperature.

The lighter is equipped with an ash guard, to prevent ashes and loose tobacco from falling on the

user's clothing and to permit the lighter to be passed around with less danger of burning the fingers.

A thermal operated circuit breaker is used to protect the element. The circuit breaker is reset manually simply by removing the plastic covered cup on the back of the lighter base and depressing the spring plunger until it indexes in position.

d. Automatic Transmission Dial Light

The transmission control dial is illuminated by a 1 CP lamp bulb located in the bottom of direction signal switch actuator cover. See Figure 8-93.

The light intensity is controlled by the light switch in the same manner as the instrument panel lights. To replace this lamp bulb, remove screw that retains bulb mounting plate to actuator cover and lower assembly out of cover.