

# GROUP 2 ENGINE

## SECTIONS IN GROUP 2

Section	Subject	Page	Section	Subject	Page
2-A	Engine Specifications . . . . .	2-1	2-E	Replacement of Crankshaft and Connecting Rod Bearings. Replacement of Piston, Rings, and Pins . . . . .	2-33
2-B	Engine Description	2-8	2-F	Cooling and Oiling Systems Service . . . . .	2-41
2-C	Engine Tune-Care and Trouble Diagnosis . . . . .	2-17	2-G	Engine Mounting Adjustment Flywheel Replacement Thread Repair . . . . .	2-47
2-D	Cylinder Head and Valve Mechanism . . . . .	2-22			

## SECTION 2-A

### ENGINE SPECIFICATIONS

#### CONTENTS OF SECTION 2-A

Paragraph	Subject	Page	Paragraph	Subject	Page
2-1	Engine Tightening Specifications . .	2-1	2-3	Engine Dimensions, Fits and Adjustments . . . . .	2-4
2-2	Engine General Specifications . . .	2-2			

### 2-1 ENGINE TIGHTENING SPECIFICATIONS

Use a reliable torque wrench to tighten the parts listed to prevent straining or distorting the parts or possibly damaging the threads. These specifications are for clean and lubricated threads only. Dry or dirty threads produce increased friction which prevents accurate measurement of tightness. It is important that these torque specifications be strictly observed. Overtightening to any extent may damage threads, thus preventing proper torque from

being attained, requiring replacement or repair of the damaged part.

**IMPORTANT:** To help prevent thread damage, all bolts used in aluminum must be free of grit and well lubricated before installation. This note applies in particular to cylinder head and main bearing cap bolts.

“Buick Special Thread Lubricant” is a specially formulated lubricant meeting Buick Specification #1379. This lube, or its equivalent should be used on all bolts

(except cylinder head bolts) installed in aluminum. “Buick Special Thread Lubricant” is available through all Buick Parts Warehouses under Gr. 8,800, Part #780131.

Cylinder head attaching bolts must be dipped in “Perfect Seal” sealing compound available through General Motors Parts Warehouses under Group 8,800, Part #980456. “Perfect Seal” sealing compound is a nonhardening lubricant and sealer that prevents seizure of head bolts in the cylinder block due to coolant seepage.

Part	Application	Thread	Torque FT. LBS.	
			V-8	V-6
Plug	Spark . . . . .	14mm	15-20	25-35
Plug	Crankcase drain . . . . .	1/2 -20	---	30-35 ---
Bolt	Water pump and timing chain cover to block . . . . .	5/16-18	---	20-25 ---
Bolt	Water pump cover to timing chain cover . . . . .	1/4 -20	---	6-8 ---
Bolt	Water outlet to intake manifold . . . . .	5/16-18	---	20-25 ---
Bolt	Intake manifold gasket clamp to block . . . . .	5/16-18	10-15	---
Bolt	Intake manifold to cylinder head . . . . .	3/8 -16	---	25-30 ---

(Lube engine oil)

**2-2 SPECIFICATIONS**

**ENGINE**

Part	Application	Thread	Torque FT. LBS.	
			V-8	V-6
Bolt	Exhaust manifold to cylinder head . . . . .	3/8 -16	- - - 10-15	- - -
Bolt	Carburetor to intake manifold . . . . .	5/16-18	- - - 12-15	- - -
Bolt	Fuel pump to timing chain cover . . . . .	5/16-18	- - - 20-25	- - -
Bolt	Camshaft Sprocket to camshaft . . . . .	7/16-20	- - - 40-45	- - -
Bolt	Rocker arm shaft bracket to cylinder head . . . . .	3/8 -16	25-30	30-35
			(Lube-Special Thread Lube #980131 or equivalent)	
Screw	Rocker arm cover to cylinder head . . . . .	1/4 -20	- - - 3-5	- - -
Bolt	Cranking motor to cylinder block . . . . .	3/8 -16	30-35	40
Bolt	Distributor clamp to timing chain cover . . . . .	3/8 -16	- - - 14-17	- - -
Bolt	Generator bracket to timing chain cover . . . . .	3/8 -16	- - - 30-35	- - -
Bolt	Generator brace to timing chain cover . . . . .	3/8 -16	- - - 30-35	- - -
Bolt	Generator to mounting bracket . . . . .	5/16-24	- - - 25-35	- - -
Bolt	Generator rear end frame to exhaust manifold . . . . .	5/16-18	- - - 14-17	- - -
Bolt	Generator brace to generator . . . . .	5/16-18	- - - 15-20	- - -
Bolt	Crankshaft bearing cap to crankcase . . . . .	1/2 -13		
	All except rear . . . . .		50-55	100-125
			(Lube-Special Thread Lube #980131 or equivalent)	
	Rear . . . . .		65-70	100-110
			(Lube-Special Thread Lube #980131 or equivalent)	
Plug	Cylinder block water drain . . . . .	1/4 -18pt.	- - - 15-20	- - -
Bolt	Cylinder head to block . . . . .	7/16-14	65-70	
			(Lube-perfect seal Part #980456 or equivalent)	
Bolt	Upper flywheel housing to cylinder block . . . . .	3/18-16	- - - 30-35	- - -
Bolt	Lower flywheel housing to block and . . . . .			
	upper flywheel housing . . . . .	5/16-18	- - - 8-12	- - -
Bolt	Flywheel to crankshaft . . . . .	7/16-20	- - - 50-60	- - -
Bolt	Harmonic balancer to crankshaft . . . . .	5/8 -18	- - -140-160-	- - -
Nut	Connecting rod bolt . . . . .	11/32-24	- - - 30-35	- - -
Bolt	Oil pan to block . . . . .	5/16-18	- Initial -	6-15 -
			-Residual	3-5 -
Bolt	Oil screen housing pipe and flange assembly . . . . .			
	to block . . . . .	1/4 -20	- - - 10-15	- - -
Bolt	Timing chain cover to block . . . . .	5/16-18	- - - 20-25	- - -
Cap	Oil pressure relief valve . . . . .		- - - 30-35	- - -
Cap	Filter by pass valve . . . . .		- - - 30-35	- - -
Screw	Oil pump cover assembly to timing chain cover . . . . .	1/4 -20	- - - 10-15	- - -
Switch	Oil pressure . . . . .		- - - 8-10	- - -
Bolt	Fan and pulley to water pump hub . . . . .	5/16-24	- - - 15-20	- - -
Bolt	Pulley and reinforcement to harmonic balancer . . . . .	5/16-18	- - - 15-20	- - -
Bolt	Engine mount to cylinder block . . . . .	7/16-14	- - - 50-55	- - -
Bolt	Engine mount to frame bracket . . . . .	7/16-20	- - - 55-65	- - -
Bolt	Intake manifold and transmission idler lever . . . . .			
	bracket to cylinder head . . . . .	3/8 -16	- - - 25-30	- - -

**2-2 ENGINE GENERAL SPECIFICATION**

Item	198 Cubic Inch V-6 Engine	215 Cubic Inch V-8 Engine
Type - No. of cylinders . . . . .	90° V-6	90° V-8
Valve arrangement . . . . .	- - - - - In Head	- - - - -
Bore and stroke . . . . .	3.625 x 3.200	3.5 x 2.800
Piston displacement . . . . .	198 cubic inches	215 cubic inches
Compression ratio		
Standard . . . . .	8.8 to 1	9.0 to 1
Power Pack . . . . .	No power pack	11.0 to 1
Export . . . . .		7.6 to 1
Brake Horsepower at RPM		
Standard . . . . .	135 @ 4600	155 @ 4600
Power Pack . . . . .	No power pack	200 @ 5000
Export . . . . .		145 @ 4600

<u>Item</u>	<u>198 Cubic Inch V-6 Engine</u>	<u>215 Cubic Inch V-8 Engine</u>
Foot Pounds Torque at RPM		
Standard . . . . .	215 @ 2400	220 @ 2400
Power Pack . . . . .	No power pack	240 @ 3200
Export . . . . .		205 @ 2400
Octane Requirement		
Standard . . . . .	84 Motor 93 Research	84 Motor 93 Research
Power Pack . . . . .	No power pack	88 Motor 99 Research
Export . . . . .		83 Research
Taxable Horsepower . . . . .	31.54	39.2
Cylinder Numbers Front to Rear		
Right Bank . . . . .	2-4-6	2-4-6-8
Left Bank . . . . .	1-3-5	1-3-5-7
Firing Order . . . . .	165432	18436572
Cylinder Block Material . . . . .	Cast Iron	Aluminum
Cylinder Liners . . . . .	None	Non Replaceable Cast Iron
Engine Manifold Vacuum at Idle		
Crankshaft Bearings Number and Type . . . . .	4 replaceable liners	5 replaceable liners
Material . . . . .	- - - - - Durex 100A - - - - -	
Bearing Which Takes End Thrust . . . . .	No. 2	No. 3
Connecting Rod Bearings - Type. . . . .	- - - - - Replaceable Liner - - - - -	
Material . . . . .	- - - - - Durex 100A - - - - -	
Piston Material and Surface Treatment	- - - Aluminum Alloy - Tin Plated - - -	
Piston Pin Offset . . . . .	.040"	None
Compression Rings Material and Surface Treatment		
Top . . . . .	Iron - Lubrited	Iron - Chrome Plated
#2 . . . . .	- - - - - Iron - Lubrited - - - - -	
Oil Ring - Type . . . . .	Dual Steel Rail With Spacer	Dual Steel Rail Chrome Plated
Oil Ring Expander . . . . .	Steel Hump Type	Steel Spacer-Expander
Location of all Piston Rings . . . . .	- - - - - Above Piston Pin - - - - -	
Camshaft Type and Material . . . . .	- - - - - Cast Alloy Iron - - - - -	
Camshaft Drive . . . . .	- - - - - Chain - - - - -	
Number and Type of Camshaft Bearings . . . . .	4 Steel Backed Babbit	5 Steel Backed Babbit
Valve Lifter Type . . . . .	- - - - - Hydraulic - - - - -	
Valve Spring Type . . . . .	- - - - - Single Helical - - - - -	
Oiling System Type . . . . .	- - - - - Forced Feed - - - - -	

<u>Item</u>	<u>198 Cubic Inch V-6 Engine</u>	<u>215 Cubic Inch V-8 Engine</u>
Oil Supplied to Bearing Surfaces		
Crankshaft, Camshaft and		
Connecting Rods . . . . .	- - - - - Full Pressure-	- - - - -
Pistons, Pins . . . . .	- - - - - Splash -	- - - - -
Cylinder Walls . . . . .	- - - - - Splash and Nozzle -	- - - - -
Valve Lifters . . . . .	- - - - - Full Pressure-	- - - - -
Rocker Arms . . . . .	- - - - - Low Pressure-	- - - - -
Normal Oil Pressure . . . . .	- - - - - 33# at 2400 RPM -	- - - - -
Oil Reservoir Capacity - Quarts. . . . .	- - - - - 4 (5 with Dry Filter) -	- - - - -
Oil Filter, Make and Type . . . . .	- - - - - (A C Type PF - 7) -	- - - - -
Cooling System Type . . . . .	- - - - - Pressure (15# Radiator Cap) -	- - - - -
Water Temperature Control . . . . .	- - - - - Thermostat -	- - - - -
Thermostat Opens at (°F.) . . . . .	- - - - - 167° to 172° -	- - - - -
Cooling System Capacity (Quarts)		
Less Heater . . . . .	10.5 -	12.0 -
With Heater . . . . .	12.0 -	13.5 -
Fan Diameter, Number of Blades		
Regular . . . . .	17.12" - 4 (Shrouded)	17.12" - 4
With Air Conditioning . . . . .	17" - 7 (Shrouded)	18" - 7
With Air Conditioner Modification . . . . .	17.12" - 4 (Shrouded)	17.12" - 4
Fan Drive		
Regular . . . . .	- - - - - Water Pump Shaft-	- - - - -
With Air Conditioning . . . . .	- - - - - Torque and Temperature -	- - - - -
	- - - - - Sensitive Clutch -	- - - - -
With Air Conditioner Modification	- - - - - Water Pump Shaft-	- - - - -

**2-3 ENGINE DIMENSIONS, FITS AND ADJUSTMENTS**

NOTE: These dimensions and limits for fit of parts apply to new parts only.  
 "T" means tight and "L" means loose.

<u>Item</u>	<u>198 Cubic Inch</u>	<u>215 Cubic Inch</u>
	<u>V-6</u>	<u>V-8</u>
Crankshaft journal diameter . . . . .	- - - - - 2.2992 -	- - - - -
Crankshaft journal to bearing clearance . . . . .	- - - - - .0005 - .0021 -	- - - - -
Crankshaft end play at thrust bearing . . . . .	- - - - - .004" - .008" -	- - - - -
Crankshaft bearing effective length		
#1 . . . . .	- - - - - .802" -	- - - - -
#2 . . . . .	- - - - - .821" -	- - - - - .802" -
#3 . . . . .	- - - - - .802" -	- - - - - .821" -
#4 . . . . .	- - - - - .802" -	- - - - -
#5 . . . . .	- - - - - None -	- - - - - .802" -
Crankpin journal diameter . . . . .	- - - - - 2.000" -	- - - - -
Crankpin journal to bearing clearance . . . . .	- - - - - .002" -	- - - - - .0022" -
Connecting rod end play on crankpin . . . . .	- - - - - .006" - .014" (Total both rods) -	- - - - -
Connecting rod bearing length . . . . .	- - - - - .737 -	- - - - -
Piston clearance in bore . . . . .	- - - - - .0005" - .0011" -	- - - - -
Piston pin diameter . . . . .	- - - - - .8747 - .8750 -	- - - - -
Piston pin length . . . . .	- - - - - 2.960 -	- - - - - 2.870 -
Piston pin fit at 70° F in piston . . . . .	- - - - - .0001" -	- - - - -
Piston pin fit in connecting rod . . . . .	- - - - - .0007" - .0015" Press	- - - - -
Piston ring side clearance in groove		
Compression ring . . . . .	- - - - - .003" - .005" -	- - - - -
Oil ring . . . . .	- - - - - .035" -	- - - - - .0095" -
Piston ring gap, compression ring in bore . . . . .	- - - - - .010" - .020" -	- - - - -
Oil ring in bore . . . . .	- - - - - .015" - .035" -	- - - - -

Item	198 Cubic Inch V-6	215 Cubic Inch V-8
Camshaft bearing journal diameter		
#1 . . . . .	- 1.755" - 1.756"	- 1.785" - 1.786"
#2 . . . . .	- 1.725" - 1.726"	- 1.755" - 1.756"
#3 . . . . .	- 1.695" - 1.696"	- 1.725" - 1.726"
#4 . . . . .	- 1.665" - 1.666"	- 1.695" - 1.696"
#5 . . . . .	- - - - -	- 1.665" - 1.666"
Camshaft journal clearance in bearings . . . . .	- - - - .0005"	- .0035" - - - - -
Valve lifter diameter . . . . .	- - - - .8422"	- .8427" - - - - -
Valve lifter clearance in crankcase . . . . .	- - - - .0015"	- .003" - - - - -
Valve lifter leakdown rate, in test fixture . . . . .	- - - - -12 to 60 sec.	- - - - -
Rocker arm ratio . . . . .	- - - - 1.6 to 1	- - - - -
Rocker arm clearance on shaft . . . . .	- - - - .0017"	- .0032" - - - - -
Valve head diameter inlet . . . . .	- - - - 1.500"	- - - - -
Valve head diameter exhaust . . . . .	- - - - 1.3125"	- - - - -
Valve seat angle inlet and exhaust . . . . .	- - - - - 45°	- - - - -
Valve stem diameter inlet . . . . .	- - - - .3412" top	.3407" bottom - -
Valve stem diameter exhaust . . . . .	- - - - .3407" top	.3402" bottom - -
Valve stem clearance in guide		
Inlet . . . . .	- - - - top .0005"	- .0025" - - - - -
	- - - - bottom .001"	- .003" - - - - -
Exhaust	- - - - top .001"	- .003" - - - - -
	- - - - bottom .0015"	- .0035" - - - - -
Valve Spring		
Valve closed pounds @ length . . . . .	- - - - -64 @ 1.640"	- - - - -
Valve open pounds @ length . . . . .	- - - - -168 @ 1.260"	- - - - -
Fan belt adjustment . . . . .	- - - - -	See Figures 2-65 and 2-66 - - -

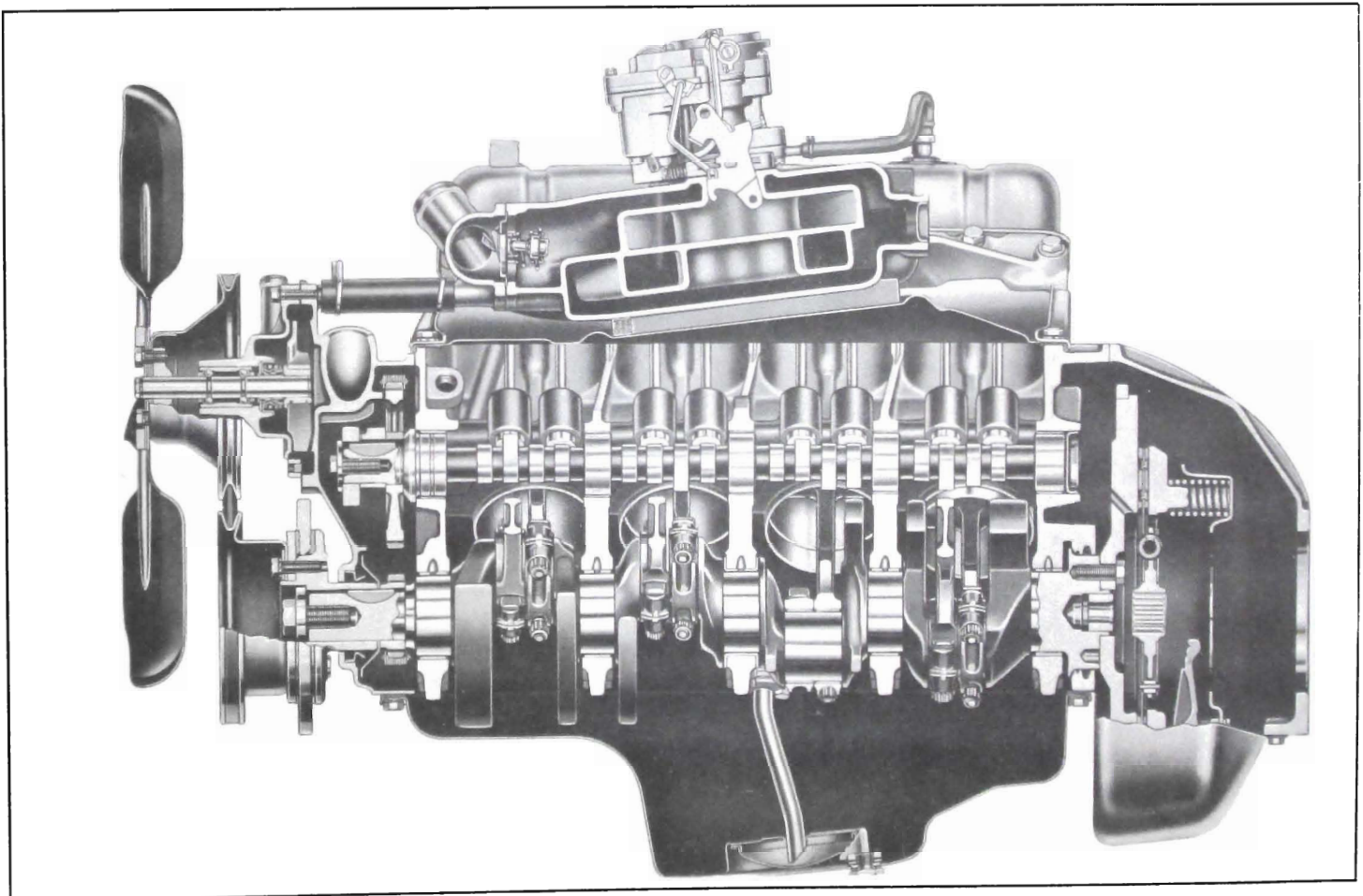

Figure 2-1—V-8 Engine Side Sectional View

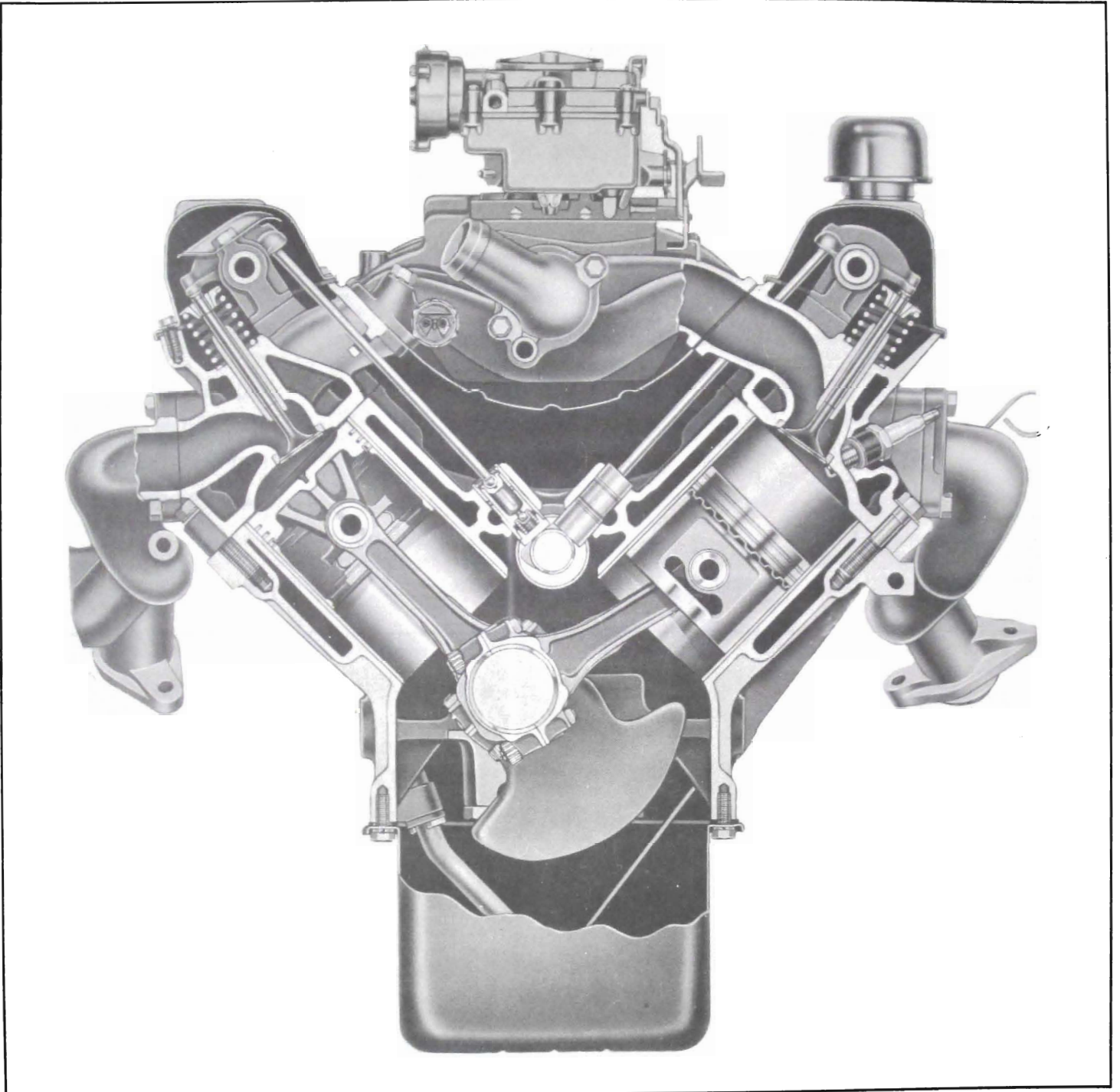

Figure 2-2—V-8 Engine End Sectional View

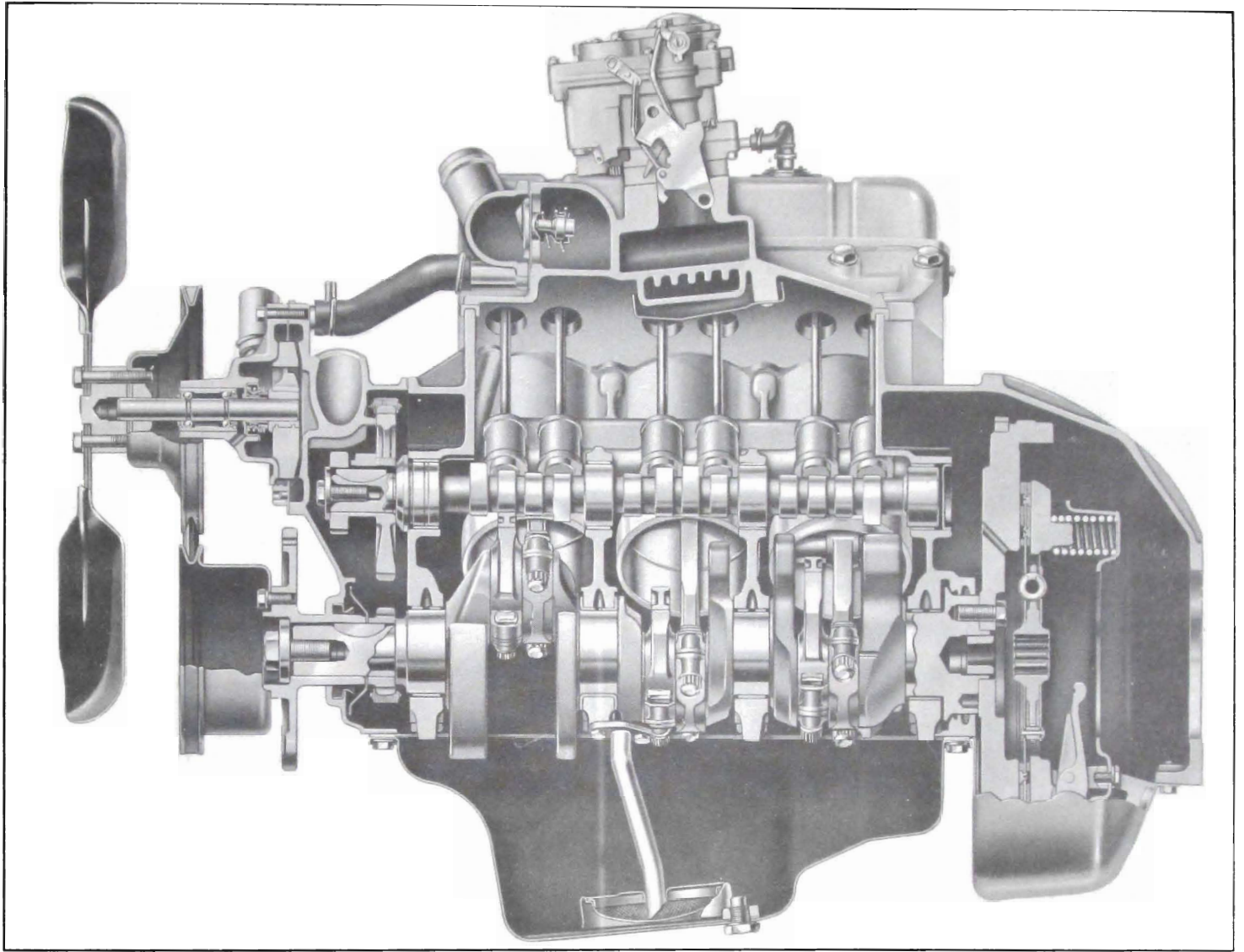

Figure 2-3—V-6 Engine Side Sectional View