

SECTION 2-G ENGINE MOUNTING REPLACEMENT, FLYWHEEL REPLACEMENT, REPAIR OF DAMAGED THREADS

CONTENTS OF SECTION 2-G

| Paragraph | Subject | Page | Paragraph | Subject | Page |
|-----------|---------------------------------------|------|-----------|----------------------------------|------|
| 2-25 | Engine Mounting Replacement | 2-47 | 2-27 | Repair of Damaged Threads | |
| 2-26 | Flywheel Replacement | 2-47 | | with Heli-Coil Inserts | 2-49 |

2-25 ENGINE MOUNTING REPLACEMENT

a. Removal of Front Mounts

1. Raise car and provide frame support at front of car.
2. Support weight of engine at forward end.
3. Remove mount to engine block bolts. Raise engine slightly and remove mount to mount bracket bolt and nut. Remove Mount. See Figure 2-69.

b. Installation of Front Mount

1. Install mount to engine block

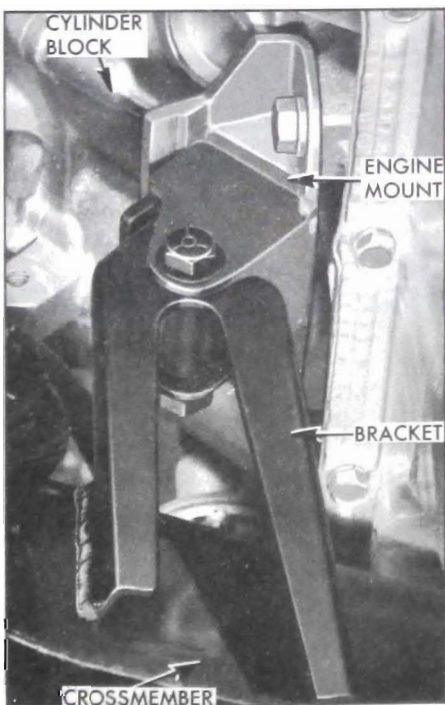

Figure 2-72—Front Engine Mount

- bolts and torque to 50-55 ft. lbs.
2. Lower engine so mounts rest on brackets in normal manner. Install mount to bracket bolts and torque to 50-60 ft. lbs.
3. Remove frame support and lower car.

c. Removal of Rear (Transmission) Mount

For details of engine and transmission mounts and transmission support installation refer to Figures 2-74 and 2-75.

2-26 FLYWHEEL REPLACEMENT

a. Removal and Replacement of Automatic Transmission Flywheel

1. Remove Transmission.
2. Remove six bolts attaching flywheel to crankshaft flange.

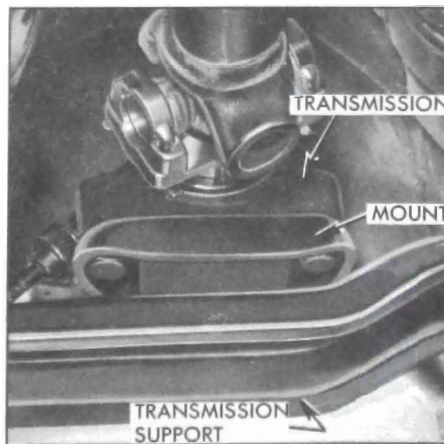

Figure 2-73—Rear (Transmission) Mount

3. Inspect flywheel. If cracked at flywheel bolt holes, replace flywheel.
4. Inspect crankshaft flange and flywheel to be installed for burrs. Remove any burrs with a mill file.
5. Install flywheel. Bolt holes are unevenly spaced so all flywheel bolts may be installed with flywheel in only one position. Install bolts and torque evenly to 50-60 ft. lbs.
6. Mount dial indicator to engine block and check flywheel run-out at three flywheel attaching bosses. Run-out should not exceed .015".

NOTE: The crankshaft end play must be held in one direction during this check.

7. If runout exceeds .015" attempt to correct by tapping high side with mallet. If this does not correct, remove flywheel and check for burrs between flywheel and crankshaft mounting flange.

b. Replacement of Flywheel or Ring Gear on Synchronesh Engine

1. Remove transmission and clutch assembly, being sure to mark clutch cover and flywheel so clutch may be reinstalled in original position.
2. Remove flywheel. Flywheel is located in a definite position on crankshaft by the attaching bolts, which are unevenly spaced.

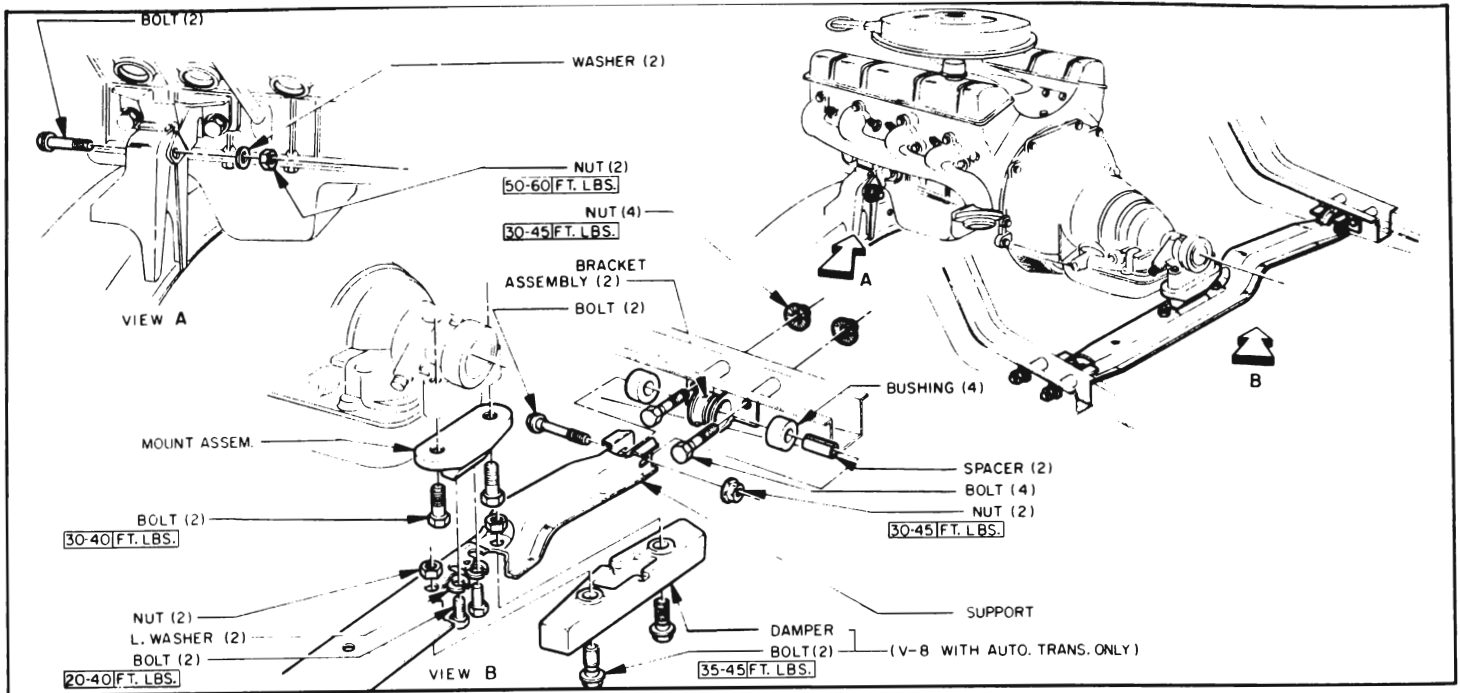

Figure 2-74—Engine and Transmission Mounting Information (Automatic Transmission equipped)

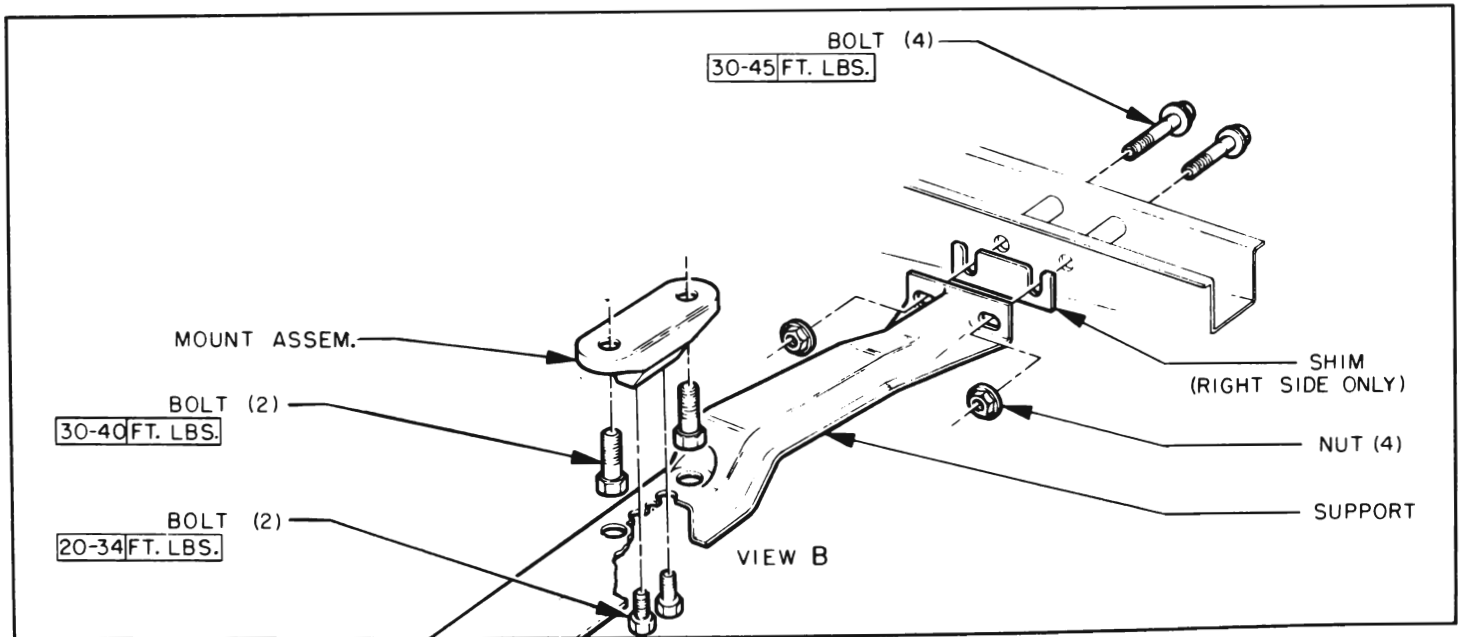

Figure 2-75—Synchromesh Transmission Support and Mounting

3. If the ring gear is to be replaced, drill a hole between two teeth and split the gear with a cold chisel.

4. Heat and shrink a new gear in place as follows:

- (a) Polish several spots on the ring with emery cloth.
- (b) Use a hot plate or slowly

moving torch to heat the ring till the polished spots turn blue (approximately 600°F.)

CAUTION: Heating the ring in excess of 800°F. will destroy the heat treatment given during manufacture.

- (c) Quickly place ring in position

against shoulder of flywheel with chamfered inner edge of ring gear toward flywheel shoulder. Allow ring to cool slowly until it is tight in place.

5. Make certain the flywheel and crankshaft flange are free of burrs that would cause runout. Then install flywheel.

2-27 REPAIR OF DAMAGED THREADS WITH HELI-COIL INSERTS

Damaged threads in tapped holes may be satisfactorily repaired with the use of "Heli-Coil" thread inserts as follows:

NOTE: Heli-Coil two times diameter inserts and installing tools are available at most automotive jobbers.

1. Prepare the hole. See Figure 2-76.

Drill out damaged threads--including stub of broken screw or stud where present--using a standard drill equal in diameter to the screw. (For a 5/16" screw thread, use a 5/16" drill.)

2. Cut new threads. See Figure 2-77.

Select the Heli-Coil tap marked with the size of the thread to be repaired and use it to tap new threads. Only Heli-Coil taps are designed to cut threads sufficiently oversize to accommodate the insert. (After the insert is installed, the hole will be back to its original size. The completed assembly will accept the original size screw or stud.)

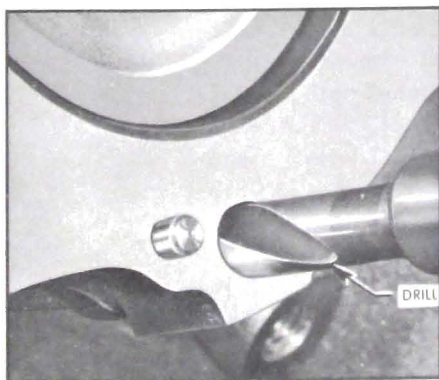

Figure 2-76—Drilling Out Damaged Threads

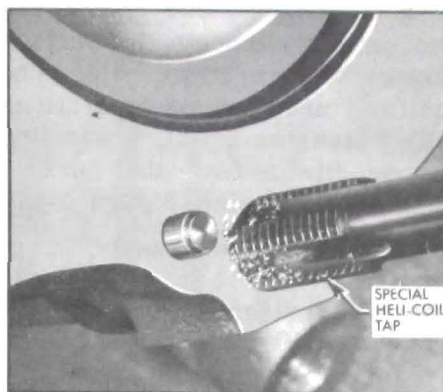

Figure 2-77—Tapping New Thread

3. Install the insert. See Figure 2-78.

(a) Select the inserting tool marked with the size of the thread to be repaired. Snap the inserting tool into place on the "T" handle provided. Then select an insert of the same size. (For a 5/16-18 thread, use a 5/16-18 insert.) The insert has a tang on one end. Face this tang away from the tip of the inserting tool. Slip the open end of the insert over the tip of the inserting tool, and engage the insert tang in the slot of the tool.

NOTE: Inserts recommended are not standard. Use only two times diameter inserts.

(b) Place the insert, still mounted on the tool, squarely over the tapped hole. With the pressure plate provided in the kit, press the insert firmly against the

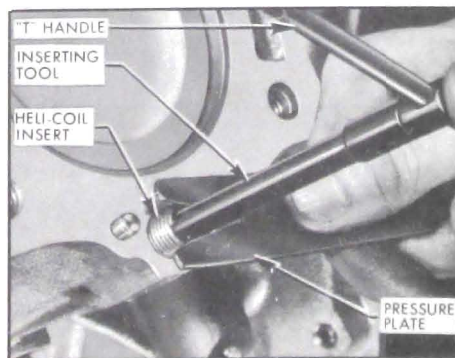

Figure 2-78—Installing Insert

mouth of the hole as illustrated in Figure 2-78. Do not apply downward pressure on the inserting tool.

(c) Maintaining pressure on the pressure plate, turn the tool clockwise, thus engaging the first few turns of the insert in the tapped threads. Pressure plate may then be removed. Continue clockwise rotation of the tool until the insert is seated from 1 to 2 turns below the start of the tapped thread. See Figure 2-79.

(d) **CAUTION:** If insert is started into hole at an angle it may begin to cross-thread. In this event do not continue beyond the first turn. Withdraw the tool, then remove the insert with fingers or pliers. Retap first few threads to be sure they are clear, then install a new insert. Cross-threaded inserts are not reusable.

4. Removing the tang.

The tang on a Heli-Coil insert should not be removed after installation except where it obstructs the bottom of the screw or affects product appearance. If the tang must be removed, use either of these two methods:

(a) Where the tang need not be retrieved from the hole after it is removed, as in most through holes and deep blind holes, use

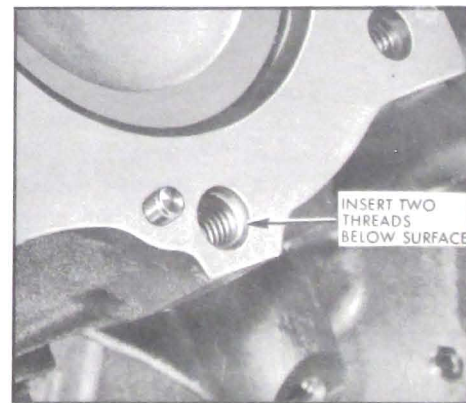

Figure 2-79—Heli-Coil Insert

the inserting tool as a tang break-off tool. Withdraw it slightly after installing insert, rotate it 1/4 turn in either direction, then bring it to bear against the tang. The slot in the tool should not engage the tang in this operation. Strike the tool sharply with a hammer. The tang will break off cleanly at a notch provided for this purpose in the bottom coil of the insert.

(b) Where the tang must be retrieved from the hole, as in shallow blind holes and in through holes opening into gear cases, etc., do not use the inserting tool to remove the tang. Use long nose pliers instead. Grasp the tang firmly and agitate with a rapid up and down motion until it parts. Do not twist pliers from side to side.

5. Make sure the surface is smooth, particularly if it is a

gasket surface. Use a flat file and carefully smooth the surface around the repaired hole. The drilling and tapping operations may raise the metal, preventing proper fits unless the surface is smoothed. See Figure 2-80.

6. How to remove inserts.

There is seldom reason to remove a properly installed insert. If improper handling of the inserting tool causes cross-threading of the first turn, proceed as described in Step 4. If an insert is completely installed, it may be removed easily as follows:

(a) With a small triangular file, cut a notch in the top coil of the insert about 1/4 turn from the end of the wire. Be careful not to damage the threads in the tapped hole.

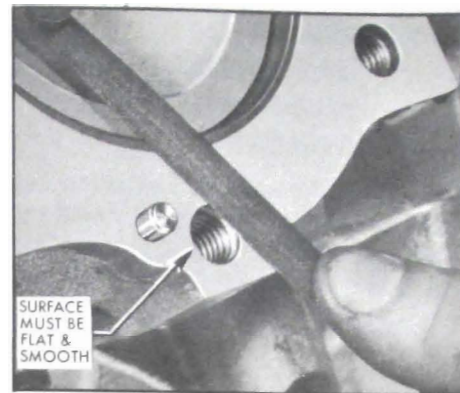
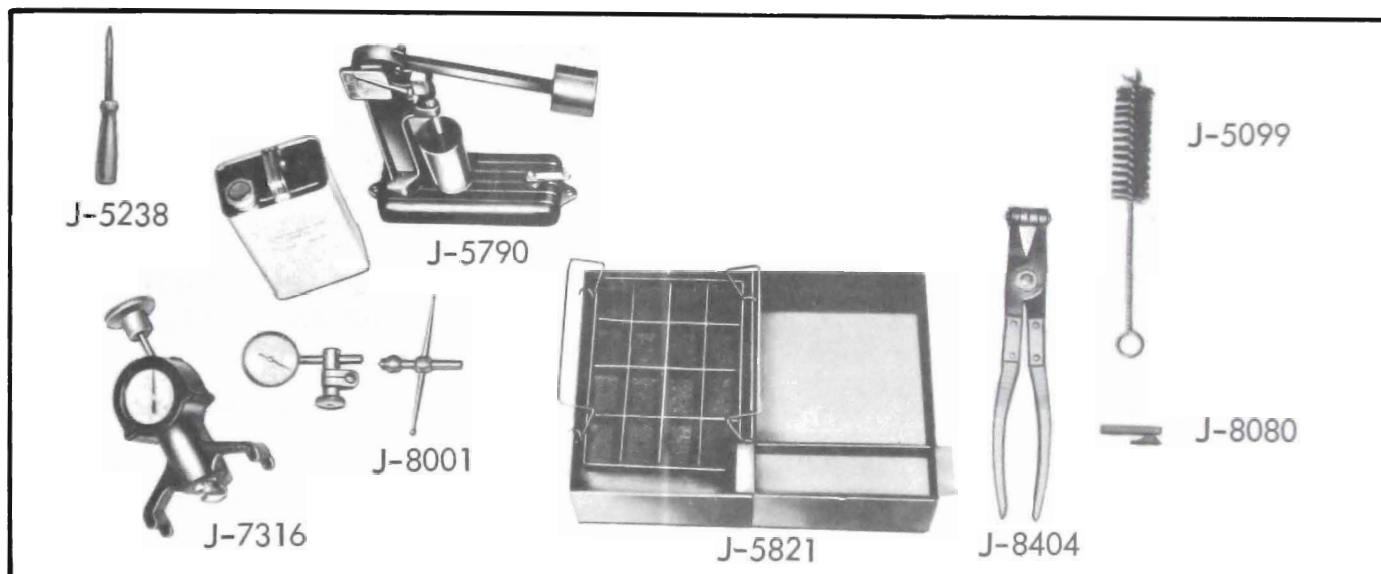
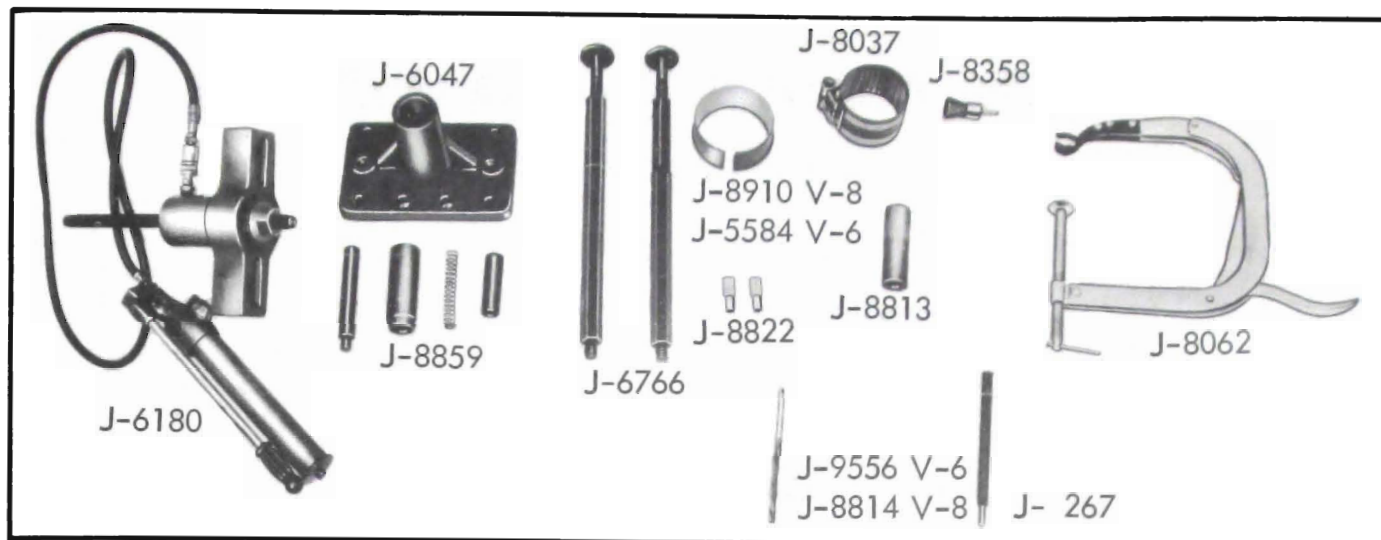

Figure 2-80—Smoothing Surface Around Insert

(b) Place one edge of a 3-edge scraper in the notch. While maintaining steady downward pressure, turn the scraper counterclockwise until the entire insert is backed out.

(c) Discard the insert. Retap the threaded hole to be sure it is clear, then install a new insert.



ENGINE SPECIAL TOOLS

| | | | |
|--------|--|--------|--|
| J- 267 | Valve Guide Remover | J-8062 | Valve Spring Compressor |
| J-5099 | Valve Lifter Body Cleaning Brush | J-8080 | Main Bearing Shell Remover |
| J-5238 | Valve Lifter Plunger Retainer Remover - Inst. | J-8358 | Carbon Remover Brush (For Aluminum Heads) |
| J-5790 | Lifter Tester (Includes Fluid) | J-8404 | Hose Clamp Pliers |
| J-5821 | Lifter Cleaning Tank | J-8813 | Valve Guide Installer |
| J-6047 | Piston Pin Remover and Installer | J-8814 | Valve Guide Reamer - V-8 |
| J-6180 | Twelve Ton Ram | J-9556 | Valve Guide Reamer - V-6 |
| J-6766 | Power Equipment Adapter Screws | J-8822 | Connecting Rod Bolt Guide Set |
| J-7316 | Belt Tension Tool | J-8859 | Piston Pin Installed |
| J-8001 | Dial Indicator Set | J-8910 | Piston Ring Compressor - V-8 |
| J-8037 | Piston Ring Compressor | J-5584 | Piston Ring Compressor - V-6 |

Figure 2-81—Engine Special Tools