

GROUP 6

REAR AXLE AND PROPELLER SHAFT

SECTIONS IN GROUP 6

Section	Subject	Page	Section	Subject	Page
6-A	Rear Axle Specifications		6-B	Rear Axle Service Procedures . . .	6-6
	Description, Trouble		6-C	Positive Traction Differential . . .	6-17
	Diagnosis	6-1	6-D	Propeller Shaft	6-21

SECTION 6-A

REAR AXLE SPECIFICATIONS, DESCRIPTION, TROUBLE DIAGNOSIS

CONTENTS OF SECTION 6-A

Paragraph	Subject	Page	Paragraph	Subject	Page
6-1	Rear Axle Specifications	6-1	6-3	Rear Axle Trouble	
6-2	Description of Rear Axle	6-2		Diagnosis	6-4

6-1 REAR AXLE SPECIFICATIONS

a. Tightening Specifications

Use a reliable torque wrench to tighten the parts listed, to insure proper tightening without straining or distorting parts. These specifications are for clean and lightly lubricated threads only; dry or dirty threads produce increased friction which prevents accurate measurement of tightness.

Part	Location	Thread Size	Torque Ft. Lbs.
Nut	Rear Universal Joint to Pinion Flange	5/16-24	12-15
Nut	Front Universal Joint to Front Companion Flange	5/16-24	12-15
Bolt	Rear Axle Housing Cover to Carrier	5/16-18	25-30
Nut	Brake Assembly and Bearing Retainer to Axle Housing	3/8 -24	45-60
Bolt	Ring Gear to Differential Case	3/8 -24	50-60
Bolt	Front Companion Flange to Transmission Shaft	3/8 -24	45-55
Bolt	Rear Lower Control Arm Bracket to Underbody	7/16-20	45-60
Bolt & Nut	Rear Upper Control Arm Bracket to Underbody	7/16-20	45-60
Nut	Rear Wheel and Drum to Axle Flange	7/16-20	55-75
Nut	Rear Shock Upper Pivot	7/16-20	45-60
Bolt	Bearing Cap to Carrier	7/16-14	70-80
Nut	Rear Shock Lower Pivot	1/2 -20	30-45
Bolt & Nut	Rear Control Arm Pivot	9/16-18	85-110
Nut	Pinion Flange to Pinion	3/4 -16	200

b. General Specifications

Items	All Series
Rear Axle Type	Semi-Floating Hypoid
Drive and Torque	Through 4 Arms
Rear Axle Oil Capacity	2 pints
Ring and Pinion Gear Set Type	Hypoid
Pinion Position	+ .0015 from marking on pinion

Items	All Series
Pinion Bearing Preload	
New Bearings	25-35 inch lbs. torque with new seal
Reused Bearings	15-25 inch lbs. torque with new seal
Ring Gear Position007 - .009 Backlash
Ring Gear Preload	
New Bearings	20-30 inch lbs. torque at ring gear without pinion
Reused Bearings	10-20 inch lbs. torque at ring gear without pinion

c. Limits for Fitting and Adjusting

Pinion Position	+ .0015 from marking - on pinion	Ring Gear Preload	
Pinion Bearing Preload		New Bearings	20-30 inch lbs. torque at ring gear without pinion
New Bearings	25-35 inch lbs. torque with new seal	Reused Bearings	10-20 inch lbs. torque at ring gear without pinion
Reused Bearings	15-25 inch lbs. torque with new seal		
Ring Gear Position007-.009 Backlash		

d. Rear Axle Gear Ratios

Gear ratios are indicated by numbers stamped on the rear side of the axle housing cover. See Figure 6-1. The letter designates the axle ratio while the number designates the day of the year that it was assembled.

also provide seats for the coil springs; the upper control arms are angle mounted to also hold the body in sidewise alignment

e. Speedometer Gears

Speedometer gears must correspond with axle ratios and tire sizes in order to have correct speedometer and odometer readings.

LETTER DESIGNATION	AXLE RATIO
A	3.08
B	3.23
C	3.36
D	2.78
E	-
F	3.90
G	4.30

6-2 DESCRIPTION OF REAR AXLE

The rear axle assembly is of the semi-floating type in which the car weight is carried on the axle shafts through ball bearings enclosed in the outer axle housing tubes. The rear axle is designed for use with an open drive line and coil springs. Drive from the axle housing is transmitted to body members through two lower and two upper control arms. Large rubber bushings at either end of these control arms are designed to absorb vibration and noise. The lower control arms

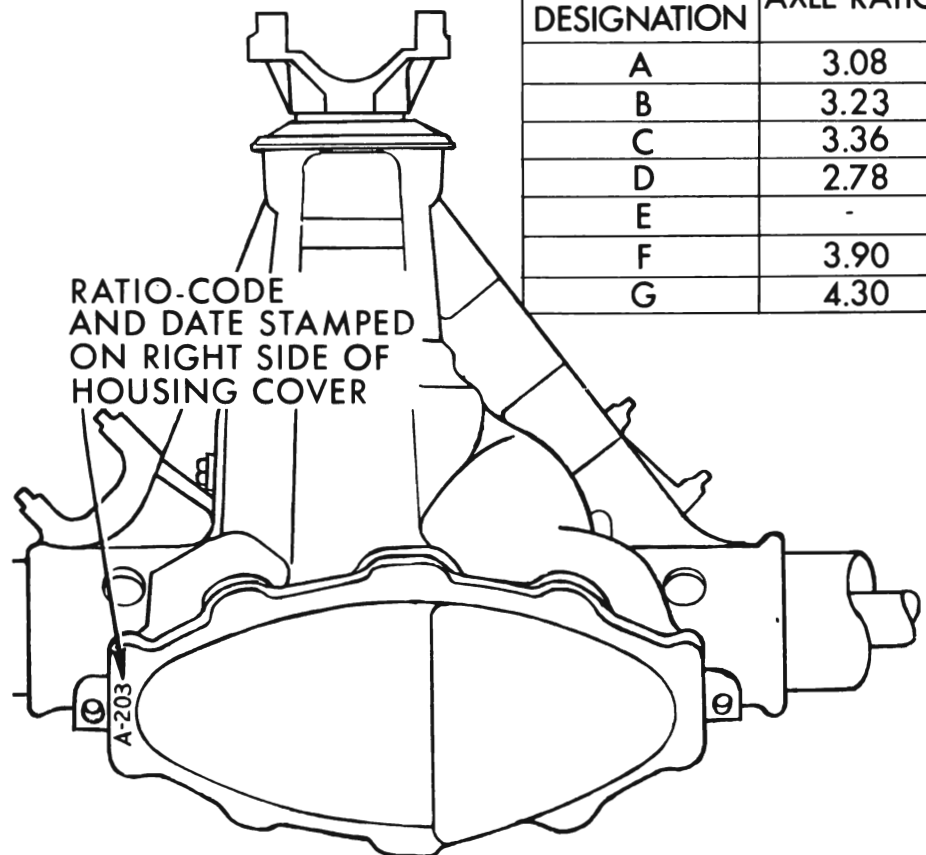

Figure 6-1—Rear Axle Markings

with the rear axle assembly. The final drive has a hypoid type ring gear and pinion with the centerline of the pinion below the centerline of the ring gear. See Figure 6-2.

The drive pinion is mounted in two tapered roller bearings which are preloaded by two selected spacers at assembly. The pinion is positioned by shims located between a shoulder on the drive pinion and the rear bearing. The front bearing is held in place by a large nut.

The differential is supported in the carrier by two tapered roller side bearings. These are preloaded by inserting shims between the bearings and the pedestals. The differential assembly is positioned for proper gear and pinion back-lash by varying these shims. The ring gear is bolted to the case. The case houses two side gears in mesh with two

pinions mounted on a pinion axle which is anchored in the case by a spring pin. The pinions and side gears are backed by thrust washers.

The axle shaft inner splines engage the differential side gears with a floating fit. The outer ends are supported in the axle housing by thrust type ball bearings which are factory packed for the life of the bearing and sealed on both sides. The axle shaft oil seals are located inboard of the bearings. The bearings are secured against shoulders on the shafts by press fit retainer rings. Retainer plates hold the bearings against shoulders in the housing. Wheel side thrust is taken at the wheel bearings, so an axle shaft may be removed simply by removing the bolts holding the retainer to the brake backing plate and axle housing flange. See Figure 6-3.

The differential carrier is a malleable iron casting with tubular axle housings pressed into the sides to form a complete assembly. A removable, heavy steel cover is bolted on the rear of the carrier to permit service of the differential without removing the rear axle from the car. A seal in the front of the carrier bears against the pinion flange. An O-ring seal in a counterbore of the pinion flange seals the splines between the drive pinion and the pinion flange. See Figure 6-2.

Brackets welded to the tubular axle housings and upper brackets integral with main carrier casting, form means of attaching the rear axle to the body. An oil feed passage to the pinion bearings and an oil return hole are provided in the carrier casting to allow lubricant to circulate.

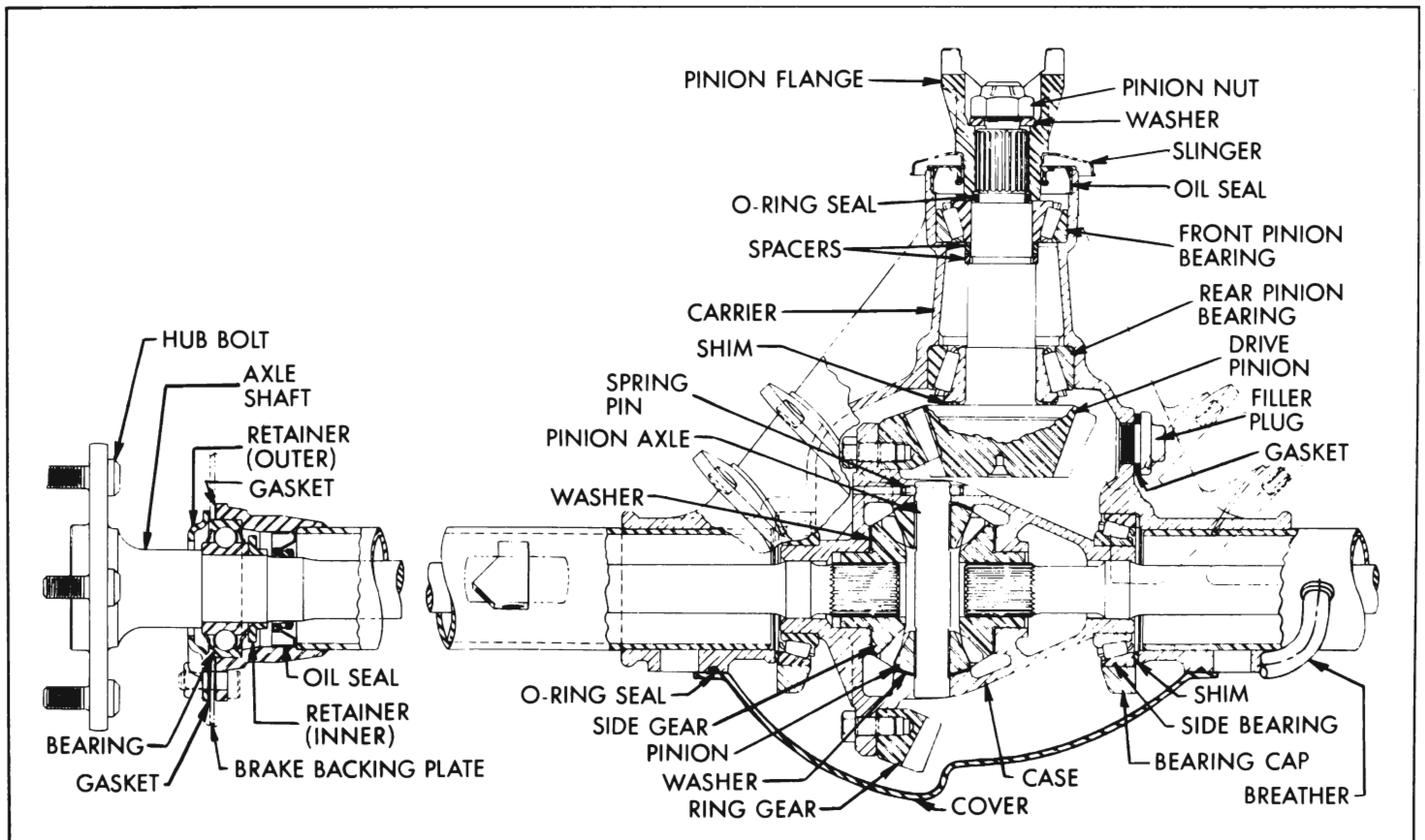

Figure 6-2—Rear Axle Assembly

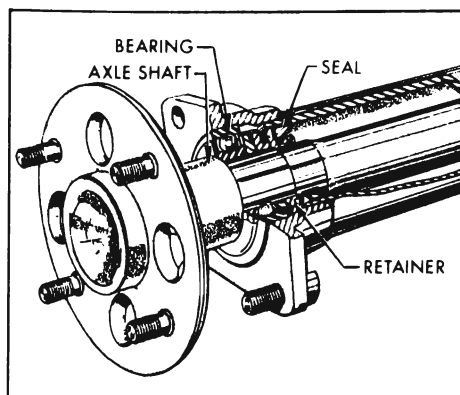

Figure 6-3—Rear Axle Shaft
Bearing and Seal

The rear axle filler plug is located on the right side of the carrier casting just ahead of and below the axle housing. A breather pipe is located on top of the right axle housing tube.

The rear brake drum is mounted directly against the axle flange on hub bolts pressed through the back of the axle flange. **CAUTION:** Left side wheel hub bolts have left hand threads.

6-3 REAR AXLE TROUBLE DIAGNOSIS

a. Elimination of External Noises

When a rear axle is suspected of being noisy it is advisable to make a thorough test to determine whether the noise originates in the tires, road surface, front wheel bearings, engine, transmission, or rear axle assembly. Noise which originates in other places cannot be corrected by adjustment or replacement of parts in the rear axle assembly.

(1) Road Noise. Some road surfaces, such as brick or rough surfaced concrete, cause noise which may be mistaken for tire or rear axle noise. Driving on a different type of road, such as smooth asphalt or dirt, will quickly show whether the road surface is the cause of noise. Road noise

usually is the same on drive or coast.

(2) Tire Noise. Tire noise may easily be mistaken for rear axle noise even though the noisy tires may be located on the front wheels. Tires worn unevenly or which have the surfaces of the non-skid divisions worn in saw-tooth fashion are usually noisy, and may produce vibrations which seem to originate elsewhere in the vehicle. This is particularly true with low tire pressure. Some designs of non-skid treads may be more noisy than others, even when tires are new.

(3) Test for Tire Noise. Tire noise changes with different road surfaces but rear axle noise does not. Temporarily inflating all tires to approximately 50 pounds pressure, for test purposes only, will materially alter noise caused by tires, but will not affect noise caused by the rear axle. Rear axle noise usually ceases when coasting at speeds under 30 miles per hour; however, tire noise continues but with lower tone as car speed is reduced. Rear axle noise usually changes when comparing "pull" and "coast," but tire noise remains about the same.

(4) Front Wheel Bearing Noise. Loose or rough front wheel bearings will cause noise which may be confused with rear axle noises; however, front wheel bearing noise does not change when comparing "pull" and "coast." Light application of brake while holding car speed steady will often cause wheel bearing noise to diminish as this takes some weight off the bearing. Front wheel bearings may be easily checked for noise by jacking up the wheels and spinning them, also by shaking wheels to determine if bearings are loose.

(5) Engine and Transmission Noises. Sometimes a noise which seems to originate in the rear axle is actually caused by the

engine or transmission. To determine which unit is actually causing the noise, observe approximate car speeds and conditions under which the noise is most pronounced, then stop car in a quiet place to avoid interfering noises. With transmission in neutral, run engine slowly up and down through engine speeds corresponding to car speed at which the noise was most pronounced. If a similar noise is produced with car standing it is caused by the engine or transmission, and not the rear axle.

b. Rear Axle Noises

If a careful test of the car shows that the noise is not caused by external items as described in subparagraph a, it is then reasonable to assume that the noise is caused by the rear axle assembly. The rear axle should be tested on a smooth level road to avoid road noise. It is not advisable to test rear axle for noise by running with rear wheels jacked up.

Noises in the rear axle assembly may be caused by faulty propeller shaft or rear wheel bearings, faulty differential or pinion shaft bearings, misalignment between two U-joints, differential side gears and pinions worn, or by a mismatched, improperly adjusted or scored ring and pinion gear set.

(1) Rear Wheel Bearing Noise. A rough rear wheel bearing produces a vibration or growl which continues with car coasting with transmission in neutral. A brinelled rear wheel bearing causes a knock or click approximately every two revolutions of rear wheel since the bearing rollers do not travel at the same speed as the rear axle and wheel. With rear wheels jacked up, spin rear wheels by hand while listening at hubs for evidence of rough or brinelled wheel bearing.

(2) Differential Side Gear and Pinion Noise. Differential side

gears and pinions seldom cause noise since their movement is relatively slight on straight ahead driving. Noise produced by these gears will be most pronounced on turns.

(3) Pinion Bearing Noise. Rough or brinelled pinion bearings produce a continuous low pitch whirring or scraping noise starting at relatively low speed.

(4) Ring and Pinion Gear Noise. Noise produced by the ring and pinion gear set generally shows up as drive noise, coast noise, or float noise.

(a) Drive noise is most evident on constant acceleration through the speed range.

(b) Coast noise is most evident when car is allowed to coast through the speed range with throttle closed.

(c) Float noise is most evident while just barely holding the car speed constant on a level road at any speed.

(d) Drive, coast, and float noises will be very rough and irregular if the differential or pinion shaft bearings are rough, worn, or loose, and will vary in tone with speed.

c. Body Boom Noise or Vibration

Objectional "body boom" noise or vibration at 55-65 MPH can be an unbalanced propeller shaft at the center of the shaft. Excessive looseness at the spline can contribute to this unbalance.

Other items that may also contribute to the noise problem are as follows:

1. Propeller shaft center bearing support rubber partially folded under the support. The support

bolted to the crossmember should also be checked for correctness of installation. A stamped letter "L" on the support should be on the left side of the car.

2. Undercoating or mud on the shaft causing unbalance.

3. Shaft balance weights missing.

4. Shaft damage such as bent, dents or nicks.

5. Tire-type roughness. Switch tires from a known good car to determine tire fault.

d. Check for Propeller Shaft Vibration

Objectionable vibrations at high speed (65 MPH or higher) may be caused by a propeller shaft that is out of balance. Out of balance may be due to a bent shaft.

To determine whether the propeller shaft is causing vibration, drive car through the speed range and note car speed at which vibration is most pronounced. Shift transmission into second gear (synchromesh) or low range (automatic)

Due to gear ratio, engine will now have to run much faster to obtain the same propeller shaft speed (shown on speedometer). To determine the same engine speed in second (synchromesh), or low (automatic) as speedometer indicated in 3rd or drive when vibration occurred, divide the car speed by the transmission gear ratio, using 1.55 for synchromesh or 1.6 for automatic. Example: If vibration is most pronounced at 65 MPH in direct

drive, the same engine speed would be produced in

second gear (synchromesh) at $65/1.55 = 42$ MPH

or in low range (automatic) at $65/1.6 = 41$ MPH

If the vibration is still present at the same engine speed whether in direct drive or in the lower gear, since the propeller shaft speed varies, this cannot be the fault. If the vibration decreases or is eliminated in the lower gear, then the propeller shaft is out of balance and should be re-balanced. See paragraph 6-18. See paragraph 6-12 for a more complete trouble diagnosis.

e. Oil Leaks

It is difficult to determine the source of some oil leaks. When there is evidence of an oil leak at these locations, the probable cause is as follows:

(1) Oil coming from the drain hole under the axle housing at the brake backing plate is caused by a leaking axle shaft seal or a leaking wheel bearing inner gasket.

(2) Oil coming from between the rear pinion flange slinger and the carrier is caused by a leaking pinion seal. Oil coming out around the pinion nut is caused by a defective "O" ring seal between the drive pinion and the pinion flange.

Even after the point of leakage has been determined, it is hard to tell whether the oil is leaking past the lip of the seal or past the O.D. of the seal. Therefore it is a good idea to make sure the leak is stopped by using a nonhardening sealing compound around the O.D. of the new seal.