

SECTION 9-C

BRAKE SERVICE, ADJUSTMENT, REPAIR PROCEDURES

CONTENTS OF SECTION 9-C

Paragraph	Subject	Page	Paragraph	Subject	Page
9-7	Filling, Bleeding, Flushing Brake Hydraulic System	9-14	9-11	Replace or Reline Brake Shoes - Repair Brake Linings	9-16
9-8	Brake Adjustment	9-15	9-12	Inspecting and Reconditioning Brake Drums	9-19
9-9	Parking Brake Adjustment	9-16	9-13	Brake Wheel Cylinder Overhaul . .	9-20
9-10	Replacing Brake Pipes	9-16	9-14	Brake Master Cylinder Overhaul . .	9-20

9-7 FILLING, BLEEDING FLUSHING BRAKE HYDRAULIC SYSTEM

a. Filling Brake Master Cylinder

The master cylinder must be kept properly filled to insure adequate reserve and prevent air from entering the hydraulic system. It must not be overfilled, however, as expansion due to heat absorbed at brakes and from engine would cause fluid to overflow through the vent. The overflow fluid would accumulate road dust and grit which increases the possibility of foreign material getting into the hydraulic system. Dirt accumulated in the vent would affect operation of the master cylinder.

The brake fluid reservoir is on the master cylinder which is located under the hood on the left side.

Thoroughly clean reservoir cover and vent cover before removal to avoid getting dirt into reservoir. Add fluid as required to bring level 1/8" below lip of reservoir opening. Use Delco Super No. 11 Hydraulic Brake Fluid or equivalent.

CAUTION: Do not use shock absorber fluid or any other fluid which contains mineral oil. Do not use a container which has been used for mineral oil. Even

a trace of mineral oil will cause swelling and distortion of rubber parts in the hydraulic brake system.

b. Bleeding Brake Hydraulic System

A bleeding operation is necessary to remove air whenever it is introduced into the hydraulic brake system. Since air is compressible and hydraulic fluid is not, the presence of air in the system is indicated by a springy, spongy feeling of the brake pedal accompanied by poor braking action.

Air will be introduced into the hydraulic system if the brake pedal is operated when the fluid is too low in master cylinder reservoir. Air will also enter the system whenever any part of hydraulic system is disconnected.

It will be necessary to bleed the hydraulic system at all four wheel cylinders if air has been introduced through low fluid level or by disconnecting brake pipe at master cylinder. If brake pipe is disconnected at any wheel cylinder, then that wheel cylinder only need be bled. If pipes are disconnected at any fitting located between master cylinder and wheel cylinders, then all wheel cylinders served by the disconnected pipe must be bled. See Figure 9-5.

c. Sequence for Bleeding Wheel Cylinders

It is advisable to bleed one wheel cylinder at a time to avoid getting fluid level in reservoir dangerously low. The correct sequence of bleeding is left front, right front, left rear, right rear. This sequence expels air from the lines and wheel cylinders nearest to the master cylinder first, and eliminates the possibility that air in a line close to the master cylinder may enter a line farther away after it has been bled.

CAUTION: Do not perform bleeding operation while any brake drum is removed.

d. Bleeding Wheel Cylinder without Pressure Tank

1. Fill master cylinder (subpar. a, above).

2. Slip a brake bleeder tube over ball of wheel cylinder bleeder valve. Place lower end of bleeder tube in a clean glass jar. Unscrew bleeder valve 3/4 of a turn. See Figure 9-9.

3. Depress brake pedal a full stroke, then allow pedal to return slowly to released position. Allowing pedal to return quickly may draw air into system. Continue operating pedal in this manner until fluid flows from bleeder tube into glass jar in a solid stream that is free of air

bubbles, then close the bleeder valve securely and remove bleeder tube.

4. Frequently check master cylinder to make sure that it contains fluid. Allowing reservoir to be emptied will cause air to be drawn into hydraulic system.

5. When bleeding operation is completed at all wheel cylinders where needed, make sure that fluid level is within 1/8" of top of reservoir, then install gasket in reservoir cover, reservoir vent and thumb screw.

6. Discard the brake fluid deposited in glass jar during bleeding operation. It is poor economy to attempt to clean fluid that has once been used.

e. Bleeding Wheel Cylinder with Pressure Tank

IMPORTANT: When using a pressure tank, air bubbles may form in the tank and enter the brake hydraulic system. To avoid this, observe the following points when handling a pressure tank: (1) Do not shake or agitate the pressure tank after air pressure has been added or is being added. (2) Allow pressure tank to stand in one position as much as possible, and bring air hose over to tank when adding head of air. (3) Make certain the valves on the pressure tank lines are not defective allowing air to be sucked in when fluid passes through the lines. (4) Pressure tank should be kept at least 1/3 full of fluid to avoid air bubbles forming. (5) If pressure tank is full of air bubbles, release air pressure and those bubbles will increase in size and be forced to top of fluid, and escape.

1. Thoroughly clean master cylinder reservoir cover and surrounding area.

2. Make sure that pressure tank is at least 1/3 full of specified brake fluid, that hose and master cylinder reservoir are filled with fluid, then attach hose to master cylinder filler opening.

3. Slip a brake bleeder tube over ball of wheel cylinder bleeder valve. Place lower end of bleeder tube in a clean glass jar. Unscrew bleeder valve 3/4 of a turn. See Figure 9-9.

4. Open pressure tank hose valve to apply fluid to master cylinder under pressure that does not exceed 35 pounds. It is not necessary to pump the brake pedal when using pressure tank.

5. When fluid flows from bleeder tube into glass jar in a solid stream that is free of air bubbles, that particular cylinder and line are bled; tighten bleeder valve securely and remove bleeder tube.

6. When bleeding operation is completed at all wheel cylinders, make sure that fluid level is 1/8" below top of master cylinder opening, then install gasket, reservoir cover vent and thumb screw.

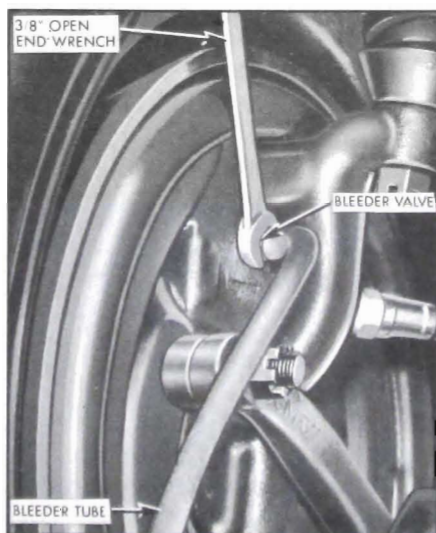

Figure 9-9—Bleeding Front Wheel Cylinder

f. Flushing Brake Hydraulic System

It is recommended that the entire hydraulic system be thoroughly flushed whenever new parts are installed in the hydraulic system. Flushing is also recommended if there is any doubt as to the grade of fluid in the system or if fluid has been used which contains the slightest trace of mineral oil.

Flushing is performed at each wheel cylinder in turn, and in the same manner as the bleeding operation except that bleeder valve is opened 1-1/2 turns and the fluid is forced through the pipes and wheel cylinder until it emerges clear in color. Approximately one pint of fluid is required to flush the hydraulic system thoroughly.

When flushing is completed at all wheel cylinders, make certain that master cylinder reservoir is filled to proper level.

9-8 BRAKE ADJUSTMENT

a. Preliminary Checks

1. Depress brake pedal firmly. If pedal travels to within 2 inches of toeboard and has a hard feel, brake shoes require adjustment or relining. However, if pedal has a spongy feel, brake system needs bleeding.

2. Remove one front wheel with hub and drum assembly. Inspect brake lining. If lining is worn nearly to rivets, reline brakes (par. 9-11).

3. Check fluid level in master cylinder reservoir and add fluid if necessary (par. 9-7).

4. Fully release parking brake lever and place transmission in neutral.

5. Pull on both ends of rear brake cable a number of times to make sure that cables operate rear

brake shoes freely and do not bind in conduits. Check for free movement of cable in brake cable sheave and check brake cable spring for tension. Replace a weak or broken cable spring.

b. Brake Pedal Height

NOTE: Brake pedal height cannot be adjusted on manual brakes.

The master cylinder non-adjustable push rod connects directly to the brake pedal. Therefore, brake pedal height depends entirely on a stop in the master cylinder, which is also non-adjustable. No external brake pedal return spring is used, so pedal return depends entirely on a spring within the cylinder.

If binding does occur, take apart and clean. Check for broken parts. Lubricate and replace.

c. Adjustment at Wheels

1. Remove adjusting hole cover from brake backing plate. Install J-21231 through adjusting hole to move actuator off adjusting screw. Use J-6166 to turn brake adjusting screw; expand brake shoes at each wheel until the wheel can just be turned by hand. See Figure 9-10. The drag should be equal at all wheels.

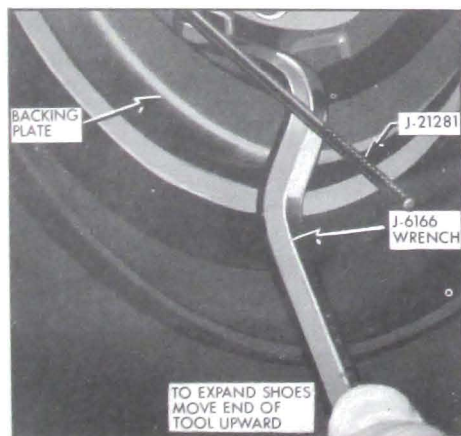

Figure 9-10—Adjusting Right Front Brake Shoes

2. Back off brake adjusting screw at each wheel 30 notches. If shoes still drag lightly on drum, back off adjusting screw one or two additional notches. **NOTE:** Brakes should be free of drag when screw has been backed off approximately 12 notches. Heavy drag at this point indicates tight parking brake cables.

3. Install adjusting hole cover in brake backing plate when adjustment is completed.

4. Check parking brake adjustment by pulling out lever. If lever pulls out more than 15 clicks, cable adjustment is too loose. If lever cannot be pulled out at least 8 clicks, cable adjustment is too tight or cables may be seized due to rust. Adjust cables as necessary (par. 9-9).

5. Road test car for service and parking brake performance. (par. 9-5).

9-9 PARKING BRAKE ADJUSTMENT

a. Adjustment

Adjustment of the parking brake is necessary whenever the rear brake cables have been disconnected or when the cables have stretched due to extended use. Need for a parking brake adjustment is indicated if the service brake operates with a good pedal reserve, but the parking brake lever pulls out more than 15 ratchet clicks.

1. Pull out parking brake lever exactly 8 ratchet clicks.

2. Hold threaded end of intermediate parking brake cable to prevent cable from twisting and tighten adjusting nut until left rear wheel can just be turned backward using both hands. See Figure 9-4.

3. Release parking brake lever and pull out exactly 3 ratchet

clicks. Check both rear wheels to make sure they turn freely in either direction.

9-10 REPLACING BRAKE PIPES

Since brake pipe assemblies (except master cylinder to distributor pipe) are not available from Buick Parts Warehouses, it is therefore necessary to order service bulk tubing and fittings to make-up any pipe assembly which is needed. All brake pipes must be made of tin or copper coated wrapped steel tubing with the ends double lap flared. **CAUTION:** Never use copper tubing because copper is subject to fatigue cracking which would result in brake failure.

To make-up a brake pipe assembly, proceed as follows:

a. Procure the recommended tubing and fittings of the correct size. (Outside diameter of tubing is used to specify size.)

b. Cut tubing to length. The correct length may be determined either by measuring the old pipe using a cord, or the length may be found in Group 4,685 of the Buick Chassis Parts Book.

c. Double lap flare tubing ends using a suitable flaring tool such as J-8051. Follow the instructions included in the tool set. **CAUTION:** Make sure fittings are installed before starting second flare.

d. Bend pipe assembly to match old pipe.

9-11 REPLACE OR RELINE BRAKE SHOES—REPAIR BRAKE LININGS

The most satisfactory method of replacing brake lining is to install new shoe and lining assemblies.

This insures brake shoes that are not distorted through use, and linings properly riveted to shoes and ground to correct radius by accurate factory machinery.

Each brake shoe and lining set listed under Group 5.017 is packed in a carton containing two primary and two secondary shoe and lining assemblies, enough for two wheels. Sets are available in standard size and also in .030" oversize for use where brake drums have been rebored.

Use brake shoe lining sets listed under Group 5.018 if the old shoes are to be relined. Each lining set is packed in a carton containing two primary and two secondary linings, enough for two wheels. Linings are shaped, drilled, and ground to correct thickness and radius, and are packaged with enough rivets for installation on shoes. Lining sets are available in standard and .030" oversizes.

Brake linings are made of asbestos for its heat resisting qualities and compounds of bonding material for strength. Some bonding materials are used for their lubricating qualities to guard against drum scoring while others are used to control the friction producing property of the lining, called "coefficient of friction". Good molded linings also have imbedded particles of material used to control friction and wear. When linings are ground, some of the surface particles may be pulled out, giving a pitted appearance. These pits do not affect lining efficiency.

The heat generated by friction will produce different effects in different compounds of bonding material. Some compounds increase friction with increased temperature, which might cause grabbing or locking. Other compounds lose friction with increased temperature, which might cause materially lowered braking power.

Brake lining compounds must be carefully selected to produce the braking friction required at the temperatures normally attained in each vehicle application.

a. Removal and Inspection

NOTE: When paragraph references in parentheses () have an asterisk (*) the operation referred to is additional work not covered by the standard replacement operation.

1. Jack up car in a safe manner, remove wheel, and brake drum (rear) or drum and hub assembly (front). **NOTE:** Stops located on the backing plates will prevent pistons from leaving the wheel cylinders; however, brake pedal must not be operated while a brake drum is removed.

NOTE: It may be necessary to back off the brake shoe adjustment before the brake drums can be removed. To back off shoe adjustment, rotate shoe adjusting screw upward. See Figure 9-11.

2. Unhook the primary and secondary shoe return springs using large pliers.

3. Remove shoe hold down springs.

4. Lift up on actuator, unhook actuating link from anchor pin, then remove.

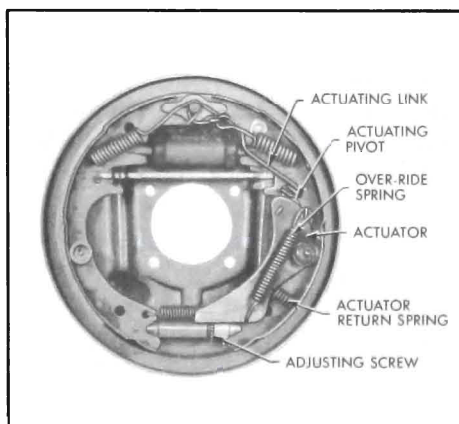

Figure 9-11—Rear Wheel Brake Assembly—Right

5. Spread shoes to clear wheel cylinder connecting links, remove parking brake strut and spring (rear only), disconnect cable from parking brake lever, remove shoes from the backing plate.

6. Separate the brake shoes by removing adjusting screw and lock spring. Remove parking brake lever from secondary brake shoe (rear only). See Figure 9-11.

7. Clean all dirt out of brake drum, using care to avoid getting dirt into front wheel bearings. Inspect drums and replace or recondition if required (*par. 9-12). If front drum and hub is removed, inspect wheel bearings and oil seal and replace faulty parts (*Group 7).

8. Blow all dirt from brake assemblies and inspect for any unusual condition.

9. Carefully pull lower edges of wheel cylinder boots away from cylinders and note whether interior is wet with brake fluid. Fluid at this point indicates leakage past piston cup, requiring overhaul of wheel cylinder (*par. 9-13).

10. Inspect all brake pipe and hose connections for evidence of fluid leakage. Tighten any leaking connection, then apply heavy pressure to brake pedal and recheck connections.

11. If working at rear wheels, inspect backing plate for oil leak past wheel bearing oil seals. Correct any leak by installation of new seals (*par. 6-6).

12. Check all backing plate attaching bolts to make sure they are tight. Clean all rust and dirt from shoe contact surfaces on plate, using fine emery cloth.

b. Relining Brake Shoes

If old brake shoes are to be relined, inspect shoes for distortion and for looseness between the rim and web; these are causes for

discarding any shoe. If shoes are serviceable, be governed by the following points in installing new linings:

1. Remove old linings by drilling out rivets. Punching rivets out will distort shoe rim. Thoroughly clean surface of shoe rim and file off any burrs or high spots.

2. Use Delco Brake lining or equivalent and the rivets included in lining package which are of correct size. The rivets must fit the holes and the solid body of rivet should extend through the shoe rim, but no farther.

3. Keep hands clean while handling brake lining. Do not permit oil or grease to come in contact with lining.

4. Start the riveting at center of shoe and lining and work toward the ends. Use a roll set for riveting; a star set might split the tabular end and then the rivet would not fill the hole. The primary lining is shorter than secondary lining, therefore the rivet holes at each end of shoe rim are not used.

5. After riveting is completed, lining must seat snugly against shoe with no more than .005" separation midway between rivets. Check with a .004" (permissible) and a .006" (no go) feeler gauge.

c. Installation and Adjustment

1. On rear brakes only, lubricate fulcrum end of parking brake lever with Delco Brake Lubricant, or equivalent, then attach lever to secondary shoe. Make sure that lever is free moving.

2. Connect brake shoes together with lock spring, then place adjusting screw in position.

CAUTION: WHEN INSTALLING ADJUSTING SCREW MAKE SURE RIGHT HAND THREAD ADJUSTING SCREW IS ON LEFT SIDE OF

CAR AND LEFT HAND THREAD ADJUSTING SCREW ON RIGHT SIDE OF CAR.

3. Lubricate shoe contact surfaces with a thin coating of Delco Brake Lubricant or equivalent. On rear brakes, sparingly apply same lubricant where brake cable contacts backing plate.

4. Place brake shoes on backing plate, at the same time engaging shoes with wheel cylinder links. The primary shoe (short lining) goes forward. On rear brakes, connect cable to parking brake lever and install strut and spring between lever and primary shoe as shown in Figure 9-10.

5. Install actuator, actuator return spring and actuating link as shown in Figure 9-10.

NOTE: If old brake shoe return springs are nicked, distorted, or of doubtful strength, it is advisable to install new ones.

6. Install shoe hold down springs.

7. Install the primary and secondary shoe return springs using large pliers being careful not to distort springs.

8. Install brake drums and wheels. Lubricate and adjust front wheel bearings. Remove all adjusting hole covers from backing plates.

9. Install J-21231 through adjusting hole to move actuator off adjusting screw. See Figure 9-10.

10. Turn adjusting screws to provide an equal two-hand drag and back-off 30 notches for proper shoe clearance (par. 9-8).

11. If any hydraulic connections were disturbed, bleed hydraulic system (par. 9-7). If new parts were installed in brake system, flushing of hydraulic system is recommended (par. 9-7).

12. Adjust parking brake as described in paragraph 9-9.

13. Check fluid level in master cylinder and add fluid if necessary.

14. Check brake pedal for proper feel and for proper return.

15. Remove jacks and road test car for proper brake action (par. 9-5).

IMPORTANT: Brakes must not be severely applied immediately after installation of new brake shoes or linings. Severe application may permanently injure new linings and may score brake drums. When linings are new they must be given moderate use for several days until burnished.

d. Repairing Brake Linings

This procedure is to be used when brake action is unequal, severe, hard, noisy or otherwise unsatisfactory, but brake linings have had very little wear.

1. Check fluid in master cylinder and add fluid if necessary.

2. Check brake pedal for proper feel and for proper return.

3. Jack up car in a safe manner and remove all wheels.

4. Remove all brake drums. **CAUTION: Brake pedal must not be operated while drums are removed.**

5. Clean all dirt out of brake drums, using care to avoid getting dirt into front wheel bearings. Inspect drums and replace or recondition if required (par. 9-12).

6. Blow all dirt from brake assemblies, then inspect brake linings for uneven wear, oil soaking, loose rivets, or imbedded foreign particles. If linings are oil soaked, they must be replaced.

7. If linings are otherwise serviceable, tighten or replace loose rivets and thoroughly clean all steel or other imbedded particles from surfaces and rivet counterbores of linings.

8. If brake linings at any wheel show a spotty wear pattern indicating uneven contact with brake drum it is advisable to true up the linings with a light grinding cut, if suitable grinding equipment is available. If brake action was unequal, severe or hard, indicating that brake shoes were not centralized in drums, the grinder may also be used to correct this condition.

Grinding equipment which locates and swings off the wheel spindle or axle shaft may be used to grind shoes concentric with drums, or a bench mounted grinder may be used to grind shoes to the proper radius (.010" less than drum radius). The instructions of equipment manufacturer must be carefully followed.

9. Check all backing plate bolts to make sure they are tight.

10. Lubricate front wheel bearings, if necessary. Install front hub and drum assemblies and adjust wheel bearings.

11. Install brake drums. Remove all adjusting hole covers.

12. Install all wheels, turn adjusting screws to provide an equal two-hand drag and back-off 30 notches (par. 9-8).

13. Install adjusting hole cover in backing plate when adjustment is complete.

14. Remove jacks and road test car for proper brake action.

IMPORTANT: Brakes must not be severely applied immediately after installation of new brake shoes or linings. Severe application may permanently injure new linings and may score brake drums. When linings are new they must be given moderate use for several days until nicely burnished.

9-12 INSPECTING AND RECONDITIONING BRAKE DRUMS

Whenever brake drums are removed they should be thoroughly cleaned and inspected for cracks, scores, deep grooves, and out-of-round. Any of these conditions must be corrected since they can impair the efficiency of brake operation and also can cause premature failure of other parts.

a. Cracked, Scored, or Grooved Drum

A cracked drum is unsafe for further service and must be replaced. Welding a cracked drum is not recommended.

Smooth up any slight scores by polishing with fine emery cloth. Heavy or extensive scoring will cause excessive brake lining wear and it will probably be necessary to re bore in order to true up the braking surface.

If the brake linings are little worn and drum is grooved, the drum should be rebored just enough to remove grooves, and the ridges in the lining should be lightly removed with a lining grinder.

If brake linings are more than half worn, but do not need replacement, the drum should be polished with fine emery cloth but should not be rebored. At this stage, eliminating the grooves in drum and smoothing the ridges on lining would necessitate removal of too much metal and lining, while if left alone, the grooves and ridges match and satisfactory service can be obtained.

If brake linings are to be replaced, a grooved drum should be rebored for use with oversize linings (subpar. c, below). A grooved drum, if used with new lining, will not only wear the lining but will make it difficult, if not impossible, to obtain efficient brake performance.

b. Out-of-round or Tapered Drum

An out-of-round drum makes accurate brake shoe adjustment impossible and is likely to cause excessive wear of other parts of brake mechanism due to its eccentric action. An out-of-round drum can also cause severe and very irregular tire tread wear.

A drum that is more than .006" out-of-round on the diameter is unfit for service and should be rebored (subpar. c, below). A drum that has more than .003" taper should be rebored. Out-of-round as well as taper and wear can be accurately measured with an inside micrometer fitted with proper extension rods.

When measuring a drum for out-of-round taper, and wear, take measurements at the open and closed edges of machined surface and at right angles to each other. Standard drums are machined to an inside diameter of 9.495" to 9.505", with runout of braking surface held within .003" front and .004" rear total indicator reading.

c. Reboring Brake Drum

If a drum is to be rebored, enough metal should be removed to obtain a true, smooth braking surface. If a drum does not clean-up when rebored to a diameter of 9.565", it must be replaced. Removal of more metal will affect dissipation of heat and may cause distortion of the drum.

A newly bored drum should always have center contact with the shoes on initial break-in, thus insuring greater uniformity in brake performance with less danger of brake pulling. To get this desired position, the shoe radius should always be .010" less than the drum radius (or .020" less on the

diameter). This fit may be accomplished by either grinding the shoes or boring the drums, whichever is the more practical.

If cleaning up a drum requires boring to a size larger than 9.550", then .030" oversize lining must be used.

Fit between the brake shoes and the drum must always be the same on both sides of the car to get equal braking action.

Brake drums may be refinished either by turning or grinding. Best brake performance is obtained by turning drums with a very fine feed. Ground and polished drums do not wear in as readily as turned drums and are more likely to cause unequal braking when new. To insure maximum lining life, the refinished braking surface must be smooth and free from chatter or tool marks.

Run-out of the refinished surface of brake drum must not exceed .003" front and .004" rear total indicator reading. Run-out (side-ways wobble) of the open edge of drum must not exceed .030".

d. Brake Drum Balance

During manufacture, brake drums are balanced within 2 inch ounces by fastening weights, as required, near the rim. These weights must not be removed.

After drums are rebored, or if difficulty is experienced in maintaining proper wheel balance, it is recommended that brake drums be checked for balance. Drums out of balance more than 2 inch ounces may be corrected by installation of service balance weights. Brake drums may be checked for balance on most off-the-car wheel balancers.

9-13 BRAKE WHEEL CYLINDER OVERHAUL

1. Remove wheel, drum, and

brake shoes. Be careful not to get grease or dirt on brake lining.

2. Disconnect brake pipe or hose from wheel cylinder and cover opening with tape to prevent entrance of dirt. Remove wheel cylinder from backing plate.

3. Remove links, boots, pistons, cups, cup expanders and spring from cylinder. Remove bleeder valve.

4. Discard rubber boots, expander assembly, and piston cups. Thoroughly clean all other parts with hydraulic brake fluid or a good grade of alcohol. **CAUTION: Do not use anti-freeze alcohol, gasoline, kerosene, or any other cleaning fluid that might contain even a trace of mineral oil.**

5. Inspect pistons and cylinder bore for scores, scratches, or corrosion. Light scratches may be polished with crocus cloth. Do not use emery cloth or sandpaper. Slight corrosion may be cleaned with fine steel wool and alcohol. If scratches or corroded spots are too deep to be polished satisfactorily the cylinder should be replaced since honing is not recommended.

6. Dip internal parts in brake fluid and reassemble wheel cylinder. When installing piston caps use care to avoid damaging the edges.

NOTE: Front wheel cylinder pistons and cups are 1" diameter and rear wheel cylinder parts are 7/8" diameter.

7. Install wheel cylinder on brake backing plate and connect brake pipe or hose.

8. Install brake shoes, drum, and wheel, then flush and bleed hydraulic system (par. 9-7).

9. Adjust brakes (par. 9-8) then road test car for brake performance (par. 9-5 and 9-6).

9-14 BRAKE MASTER CYLINDER OVERHAUL

a. Removal of Brake Master Cylinder

1. Remove connector from stop light switch. Disconnect brake pipe from master cylinder and tape end of pipe to prevent entrance of dirt.

2. Disconnect brake pedal from master cylinder push rod by removing retainer pin, washer and clevis pin. See Figure 9-6.

3. Remove two nuts holding master cylinder to dash panel and remove cylinder from car. Be careful not to drip brake fluid on exterior paint.

4. Clean outside of master cylinder thoroughly. Remove reservoir cover, turn cylinder over, and pump push rod by hand to drain all brake fluid. Always discard used fluid.

b. Disassembly of Brake Master Cylinder

1. Remove rubber boot. Remove lock ring, then remove push rod with stop plate. See Figure 9-11.

2. Remove piston with secondary cup, primary cup, spring, check valve, and valve seat washer.

3. Discard boot, lock ring, piston and rubber cups, spring, check valve, and valve seat washer. These parts are furnished in the master cylinder repair kit (group 4.649).

4. Remove reservoir cover and gasket. Thoroughly clean master cylinder with alcohol. **CAUTION: Do not use anti-freeze alcohol, gasoline, kerosene, or any other cleaning fluid that might contain even a trace of mineral oil.**

c. Inspection of Brake Master Cylinder

Inspect cylinder bore for scores,

scratches, or corrosion. Light scratches in cylinder bore may be polished with crocus cloth. Do not use emery cloth or sandpaper. Slight corrosion may be cleaned with fine steel wool and alcohol.

If scratches or corroded spots are too deep to be polished satisfactorily the cylinder should be replaced since honing is not recommended and oversize pistons and cups are not furnished for service.

Wheel and master cylinder bores have a hard, highly polished "bearingized" surface produced by diamond boring followed by rolling under very heavy pressure. Honing destroys the bearingized surface, leaving a softer and rougher surface which will cause more rapid wear of pistons and rubber cups. Higher friction produced by the rougher surface will also reduce braking power for a given pressure on brake pedal.

The maximum allowable clearance between piston and cylinder bore is .0055". If this clearance

is increased by honing, the heavy pressure of brake fluid may force rubber of the cup into the clearance and cause sticking or early failure of the cup. If a choice must be made between honing or replacement of the cylinder, it must be remembered that while a new cylinder may be more expensive a honed cylinder may not give satisfactory length of service.

Make certain that compensating port in cylinder is clear; however, do not run a wire through port as this may result in leaving a burr which will cut a groove in primary cup.

d. Assembly of Brake Master Cylinder

1. Dip all internal parts in clean brake fluid just before installation. Also wet master cylinder bore with brake fluid.
2. Install valve seat washer, check valve, spring, primary cup, and piston with secondary cup. Then install push rod and stop plate assembly. Hold push rod in and install lock ring.

Check for proper seating of lock ring with a hard pull on push rod.

3. Install rubber boot. Then install reservoir cover and gasket and wing nut finger tight.

e. Installation of Brake Master Cylinder

1. Install master cylinder on dash panel. Torque nuts to 25 foot pounds.
2. Connect push rod to brake pedal by installing clevis pin, special washer and retainer pin.
3. Connect brake pipe to master cylinder. Install wiring connector on stop light switch.
4. Bleed hydraulic system as described in paragraph 9-7. Bleed left front wheel cylinder first and check for proper pedal feel. If system still has air in it, bleed other three wheel cylinders. After bleeding, bring fluid to 1/8" below lip of reservoir opening.
5. Road test car for proper brake performance (par. 9-5).

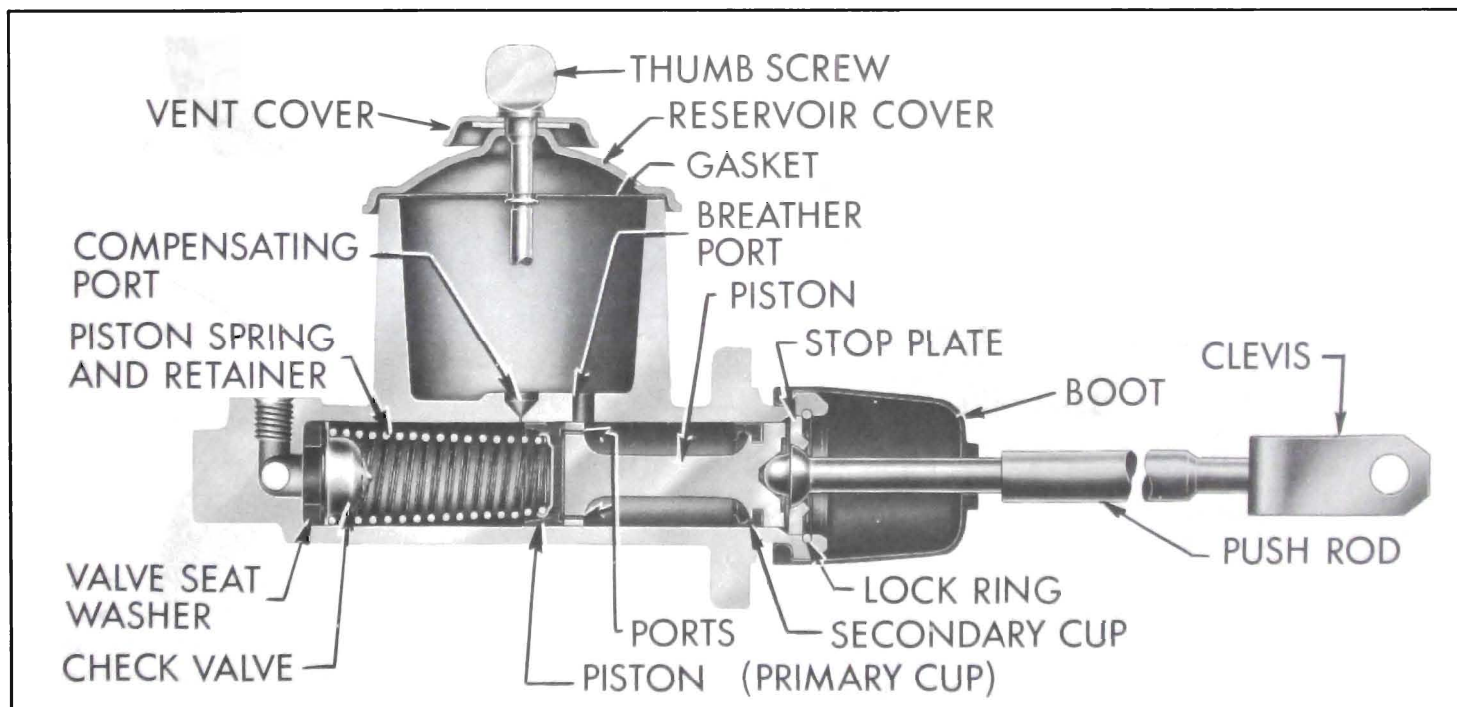

Figure 9-12—Brake Master Cylinder