

SECTION 4-C

4-SPEED SYNCHROMESH TRANSMISSION

CONTENTS OF SECTION 4-C

Paragraph	Subject	Page	Paragraph	Subject	Page
4-13	Transmission Specifications	4-22	4-17	Removal and Installation of Transmission	4-26
4-14	Transmission Description	4-24	4-18	Disassembly of Transmission	4-27
4-15	Transmission Trouble Diagnosis	4-25	4-19	Cleaning and Inspection	4-30
4-16	Side Cover Removal and Installation	4-26	4-20	Assembly of Transmission	4-31

4-13 4-SPEED TRANSMISSION SPECIFICATIONS

a. Tightening Specifications

Part	Location	Thread Size	Torque Ft. Lbs.
Bolt	Front bearing retainer to transmission case	5/16-18	15-20
Bolt	Side Cover Bolts	5/16-18	15-20
Nut	Shift lever to shaft	5/16-18	12-18
Bolt	Transmission to flywheel housing	1/2-13	45-60
Bolt	Flywheel Housing to engine	3/8-16	30-35

b. 4-Speed Transmission Specifications

Mounting	Unit with Engine
Oil Capacity, Pints	2 1/2
Type of Gearing	All Helical
Transmission Ratio	
Fourth	1.00:1
Third	1.51:1
Second	1.89:1
First	2.54:1
Reverse	2.61:1

c. Speedometer Gear

Speedometer Worm on Main Shaft	Press Fit
Teeth on Worm for Axle Ratios 3.08 and 3.36	8
Teeth on Worm for Axle Ratios 2.78	9
Teeth on Worm for Axle Ratios 3.90 and 4.30	6

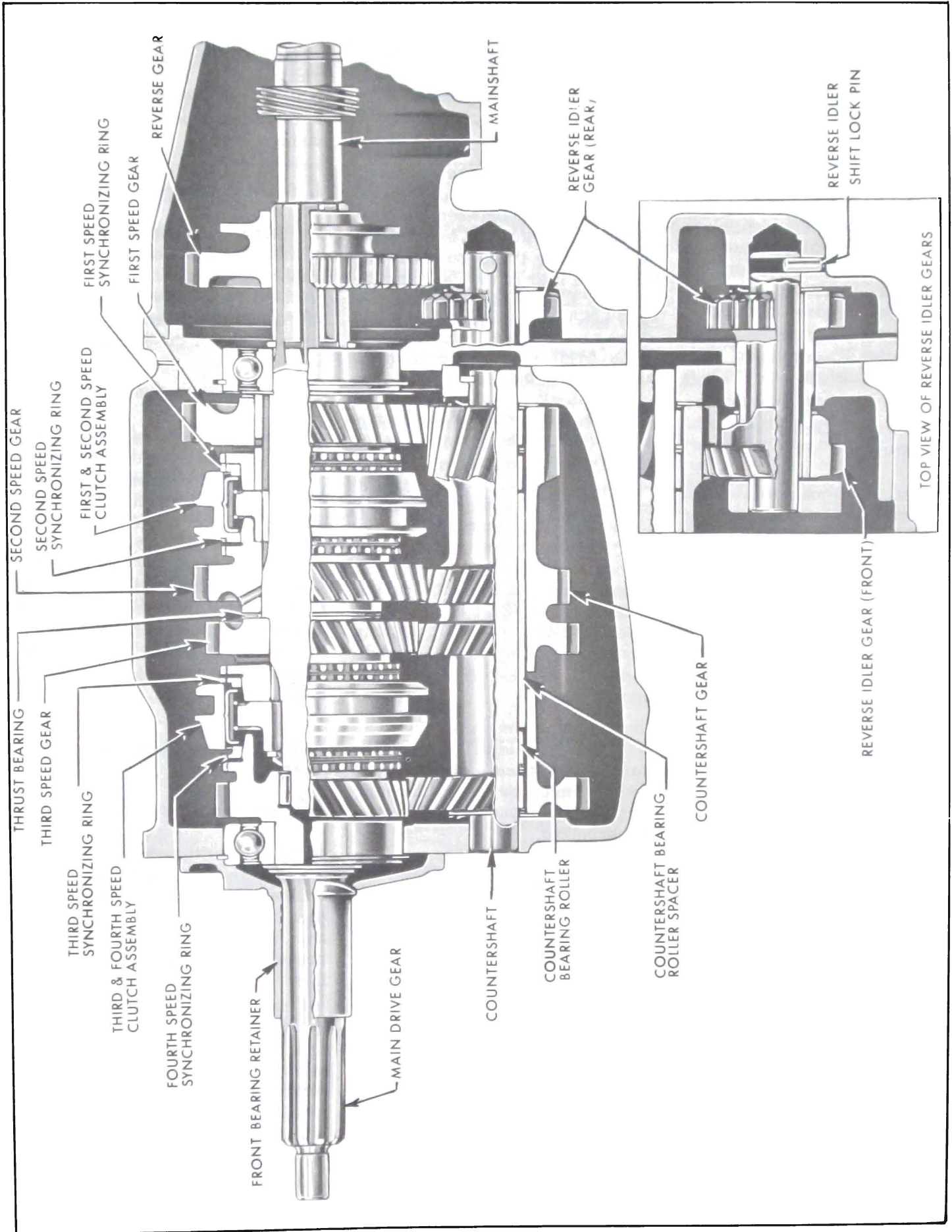

Figure 4-34—Four Speed Synchromesh Transmission

4-14 4-SPEED TRANSMISSION DESCRIPTION

The 4-speed synchromesh transmission is solidly bolted to the rear face of the flywheel upper housing to form a unit assembly with the engine. The transmission main drive gear shaft extends through the clutch driven plate into a bronze bushing seated in the rear end of the engine crankshaft. The front bearing retainer projects into a bore in the flywheel housing, serving as a pilot to center the transmission with the engine crankshaft.

a. Transmission Gears and Shafts

The transmission main drive gear is supported by a ball bearing which is a slip fit in the front wall of the transmission case. The inner race of the bearing is held tight against a shoulder on the drive gear. The outer race of the bearing is grooved for a snap ring which fits between the transmission case and the front bearing retainer to hold the bearing and main drive gear in place. See Figure 4-34.

The front end of the transmission main shaft is piloted in the bored rear end of the main drive gear by 14 needle rollers. The rear end of the main shaft is supported by a heavy-duty bearing identical to the one which supports the main drive gear. The inner race of the rear bearing is grooved for a snap ring which fits in the rear bearing retainer. The outer race of the bearing is retained by a snap ring in a groove in the shaft.

The transmission counter gear is carried on a double row of needle rollers on each end of the counter shaft. A tubular spacer separates the four sets of needle rollers and two washer-type spacers separates each set of needle rollers. See Figure 4-61. Two spacers

are located at the outer ends of each set to hold the rollers in position. End thrust is taken on thrust washers located between the ends of the gear and the front and rear of the case.

The two-piece reverse idler gear is carried on bronze bushings while thrust is taken on thrust washers located between the front of the gear and the back of the reverse idler thrust boss and between the rear of the gear and the reverse idler shaft boss in the case extension.

b. Gear Ratios

All four forward gears are provided with synchronizing clutches which can be engaged while the car is in motion. Closely spaced gear ratios of 2.54 (first), 1.89 (second), 1.51 (third) and 1.00 (fourth) provide excellent ratio matching with minimum loss of engine speed at the shift points. Reverse gear (2.61 ratio) is not synchronized; therefore, vehicle must be brought to a complete stop before engaging reverse gear.

The transmission may be used as an aid in deceleration by downshifting in sequence without double clutching or gear clashing, due to all forward speeds being synchronized.

c. Speedometer Gears

The speedometer driving worm gear is pressed on the transmission main shaft. When changing rear axle ratios it is necessary to change the driven gear, and on some axle ratios it is necessary to change the driving worm gear. The speedometer driven gear assembly consists of a sleeve, a gear and shaft, an O-ring sleeve seal, a sleeve retainer and bolt. The driven gear sleeve is a slip fit in the rear extension. The sleeve is held in place by a retainer which fits into a slot in the

sleeve and is bolted to the rear bearing retainer. The gears are lubricated by splash from the transmission. The speedometer cable is attached to the sleeve by a threaded sleeve on the cable casing.

d. Front Companion Flange

The front companion flange is splined to the rear end of the transmission main shaft and is retained by a heavy steel washer and bolt. An oil seal is located in the rear end of the case extension.

e. Shift Linkage

Gearshifting is manual through a floor-type gear shift lever which activates shift control rods connected to the transmission cover shifter levers for first through fourth gears, and to the reverse lever located in the case extension. The shifter lever to the rear of the transmission cover controls the first and second speed gears, while the lever to the front controls the third and fourth speed gears.

f. Power Flow Through Transmission

1. Operation in Neutral

In neutral, with engine clutch engaged, the drive gear turns the countergear. The countergear then turns the third, second, first, and reverse idler gears. But, because the third and fourth and first and second speed clutch

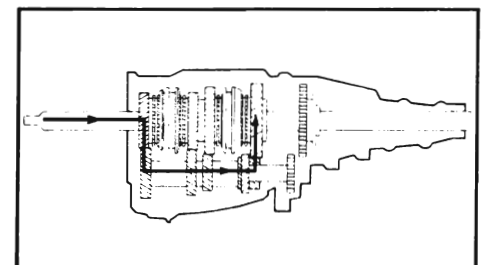

Figure 4-35—Neutral

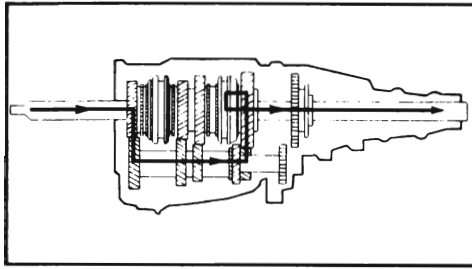

Figure 4-36—1st Gear

(sleeves) are neutrally positioned, and the reverse speed gear is positioned at the rear, away from the reverse idler gear, power will not flow through the mainshaft. See Figure 4-35.

2. Operation in First

In first speed, the first and second speed clutch (sleeve) is moved rearwards to engage the first speed gear, which is being turned by the countergear. Because the first and second speed clutch (hub) is splined to the mainshaft, torque is imparted to the mainshaft from the first speed gear through the clutch assembly. See Figure 4-36.

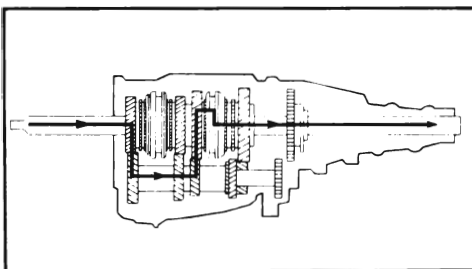

Figure 4-37—2nd Gear

3. Operation in Second

In second speed, the first and second speed clutch (sleeve) is moved forward to engage the second speed gear, which is being turned by the countergear. This engagement of the clutch (sleeve) with the second speed gear imparts torque to the mainshaft because the first and second speed clutch (hub) is splined to the mainshaft. See Figure 4-37.

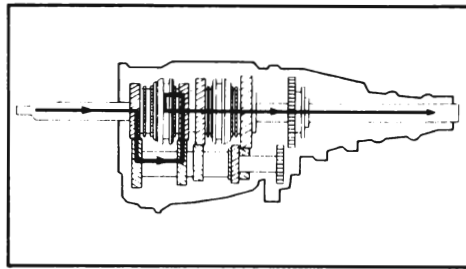

Figure 4-38—3rd Gear

4. Operation in Third

In third speed, the first and second speed clutch assumes a neutral position. The third and fourth speed clutch (sleeve) moves rearward to engage the third speed gear, which is being turned by the countergear. Because the third and fourth speed clutch (hub) is splined to the mainshaft, torque is imparted to the mainshaft from the third speed gear through the clutch assembly. See Figure 4-38.

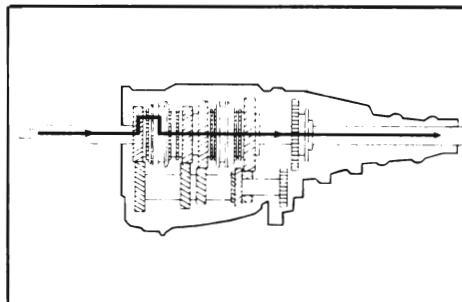

Figure 4-39—4th Gear

5. Operation in Fourth

In fourth speed, or direct drive, the third and fourth speed clutch (sleeve) is moved forward to engage the main drive gear and the first and second speed clutch remains in a neutral position. This engagement of the main drive gear with the third and fourth speed clutch assembly imparts torque directly to the mainshaft. See Figure 4-39.

6. Operation in Reverse

In reverse speed both clutch assemblies assume a neutral position. The reverse speed gear is

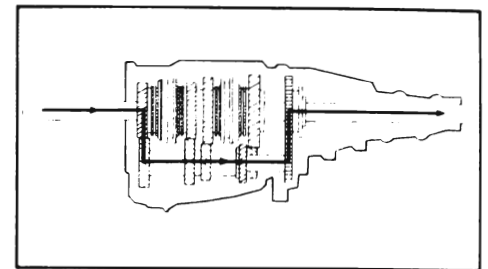

Figure 4-40—Reverse

moved forward to engage the rear reverse idler gear, which is being turned by the countergear. Because the reverse speed gear is splined to the mainshaft, this engagement causes the mainshaft to turn; however, because power flows from main drive gear to countergear and through reverse idler gear to reverse speed gear, the direction of rotation will be opposite that of the engine. See Figure 4-40

4-15 TRANSMISSION TROUBLE DIAGNOSIS

a. Hard Shifting and Block-Out

Hard shifting may be caused either by improper linkage adjustment or by conditions in the transmission assembly.

b. Noise in Neutral

With the car standing, engine running, and transmission in neutral, the transmission parts in operation are: main drive gear and bearing, countergear and bearings, reverse idler gear, first speed gear, second speed gear, third speed gear. Disengaging the clutch will stop movement of all these parts. By disengaging and engaging the clutch it can be determined whether the noise originates in these transmission parts and whether the noise is normal. Noise in neutral in the form of a constant regular click is usually caused by a nicked gear or bearing.

c. Gear Jump-Out

In any case of gear jump-out, first check the adjustment of the gear shift control mechanism. Make certain that interlock balls have full engagement in the notches in the shift shaft cam through all speed positions including neutral.

Gear jump-out in fourth speed may be caused by misalignment between the flywheel housing hole and the crankshaft. Check bore and face run out. It must not exceed .005".

Gear jump-out in any transmission speed position may be caused by loose fit of the bearings or bushings involved, a weak interlock spring, loose fit of the synchronizing hub on the main shaft, loose fit of the first-reverse gear on the main shaft, worn teeth on mating gears. All items should be carefully inspected.

d. Scored or Broken Gear Teeth

Gear teeth will be seriously damaged and possibly broken by failure of the car operator to fully engage the gears on every shift before engaging the clutch and applying engine power.

Considerable damage to gears and bearings may result from running at abnormal speeds in reverse, first and second speed gears. This practice is also detrimental to the engine.

4-16 TRANSMISSION SIDE COVER REMOVAL AND INSTALLATION

NOTE: It is not necessary to remove transmission from vehicle for inspection or replacement of parts in transmission side cover assembly, but the side cover assembly itself must be removed from the transmission case.

a. Removal

1. Remove drain plug at the bottom of transmission and drain lubricant.
2. Disconnect first, second, third and fourth shift rods from levers. See Group 4A.
3. Remove transmission side cover assembly from transmission case.
4. Remove the outer shifter lever nuts and lockwashers and pull levers from shafts.
5. Carefully push the shifter shafts into cover, allowing the detent balls to fall free, then remove both shifter shafts.
6. Remove interlock sleeve, interlock pin and poppet spring.
7. Replace necessary parts.

b. Installation

1. Install interlock sleeve and one shifter shaft. Place steel detent into sleeve followed by poppet spring and interlock pin.
2. Start second shifter shaft into position and place second detent ball on poppet spring. Compress ball and spring with screwdriver and push the shifter shaft fully in.
3. With transmission in neutral and shifter forks and levers in place, lower side cover into place.



Figure 4-41—Side Cover

Install attaching bolts, using sealer on lower right bolt (see Figure 4-41), and tighten evenly.

4-17 REMOVAL AND INSTALLATION OF 4-SPEED TRANSMISSION

a. Removal of Transmission

1. If transmission is to be disassembled, drain transmission lubricant.
2. Mark propeller shaft and front companion flange so that these parts can be reassembled in same relative position.
3. Remove the U-bolts attaching the propeller shaft to front companion flange. Slide propeller shaft rearward as far as possible for working clearance.
4. Remove screws retaining chrome ring to floor pan and remove.
5. Remove metal boot retainer to floor plate attaching screws, slide boot over stick shift.
6. Disconnect speedometer cable from transmission.
7. Disconnect shift control rods from the shifter levers at the transmission.
8. Loosen all three exhaust pipe ball joints so that transmission and rear end of engine can be lowered.
9. Remove two bolts attaching transmission mounting pad to transmission support. Leave mounting pad bolted to transmission. See Figure 4-42.
10. Place a flat wood block on jack. Jack under engine pan until transmission mounting pad just clears transmission support.

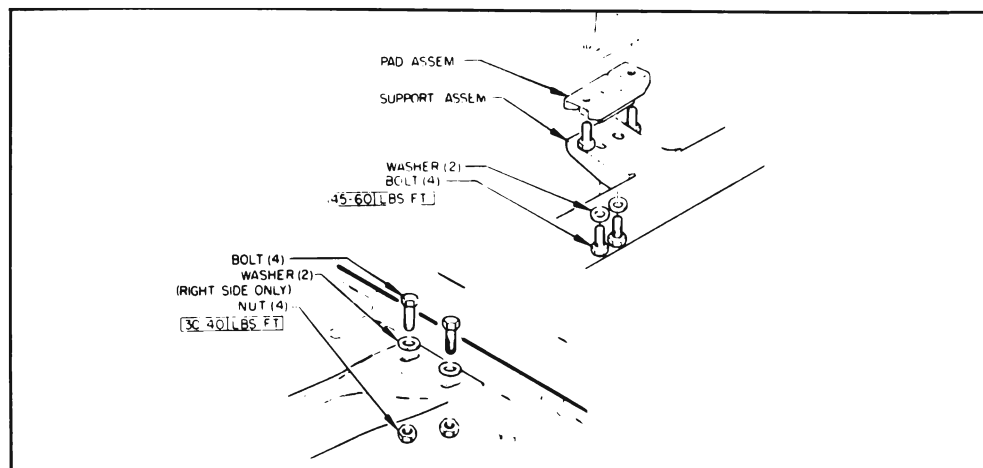

Figure 4-42—Transmission Mounting

11. Remove four bolts attaching transmission support to body members. Remove support, then lower jack so that transmission will clear underbody during removal.

12. Remove upper left transmission to flywheel housing bolt and install a J-1126 guide pin; remove lower right bolt and install a guide pin.

13. Remove other two transmission to flywheel housing bolts. Slide transmission straight back until drive gear shaft is clear of flywheel housing, then lower transmission.

CAUTION: If weight of transmission is allowed to rest on main drive gear while drive gear splines are in clutch driven plate, driven plate may be damaged.

b. Installation of Transmission

1. Lightly coat splines on end of main drive gear with Lubriplate for a distance of approximately 1 inch. Fill groove in inner surface of throw-out bearing with wheel bearing grease.

2. Make certain that front face of transmission case and rear face of flywheel housing are absolutely clean. Install J-1126 guide pin in lower right hole of flywheel housing.

3. Lift transmission into place on guide pins and slide straight forward, meanwhile fully supporting transmission. Rotate companion flange as required to engage drive gear with driven plate splines. **Caution:** If weight of transmission is allowed to rest on main drive gear shaft before shaft engages pilot bushing in flywheel, driven plate may be damaged.

4. Install two transmission to flywheel housing bolts; remove guide pins and install other two bolts. Tighten all four bolts securely.

5. Raise jack under engine pan so that transmission mounting pad will clear transmission support.

6. Install transmission support, leaving four nuts loose. Lower jack so that transmission rests on support.

7. Install two bolts attaching mounting pad to support, then tighten all six bolts securely.

8. Align exhaust system, if necessary, and tighten all bolts.

9. Connect speedometer cable to transmission.

10. Install shift linkage to transmission.

11. Adjust shift linkage as described in Group 4A.

12. Reinstall rubber boot and chrome ring to floor pan.

4-18 DISASSEMBLY OF 4-SPEED TRANSMISSION

a. Disassembly

1. Remove transmission side cover assembly from transmission case. **NOTE:** If cover assembly is to be disassembled for inspection or replacement of worn parts, follow procedures 2 through 6, Section 4-16.

2. Remove four bolts from front bearing retainer and remove retainer and gasket.

3. Drive lock pin up from reverse shifter lever boss, as shown in Figure 4-43, and pull shifter shaft out about 1/8". This disengages the reverse shift fork from reverse gear.

4. Remove five bolts attaching the case extension to the rear bearing retainer. Tap extension with soft hammer in a rearward direction to start. When the reverse idler shaft is out as far as it will go, move extension to left so reverse fork clears reverse gear and remove extension and gasket.

5. Remove rear bearing snap ring on mainshaft.

6. Remove case extension oil seal. See (Figure 4-44).

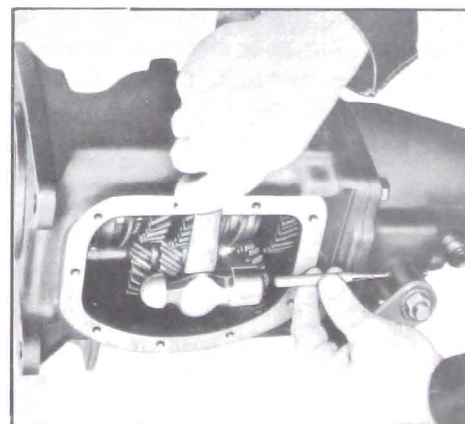

Figure 4-43—Removing Reverse Shifter Shaft Lock Pin

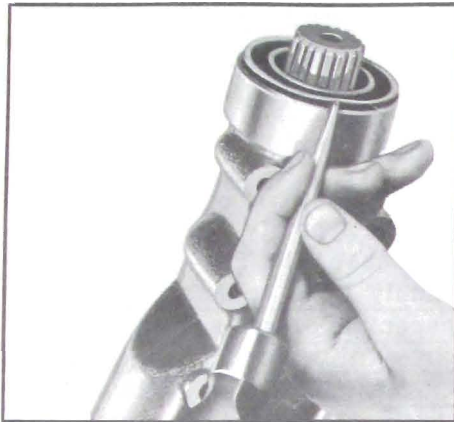

Figure 4-44—Removing Extension Oil Seal

7. Remove the speedometer gear with J-8760 as shown in Figure 4-45.

8. Remove the reverse gear, reverse idler gear and tanged thrust washer.

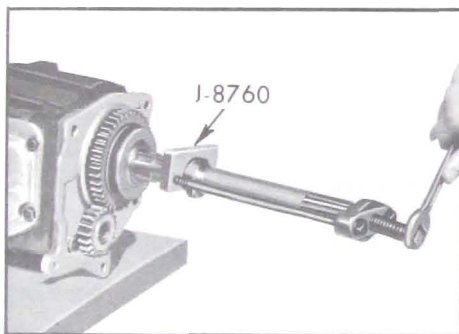

Figure 4-45—Removing Speedometer Gear

9. Remove the self-locking bolt attaching the rear bearing retainer to transmission case. Carefully remove the entire mainshaft assembly.

10. Unload bearing rollers from main drive gear and remove fourth speed synchronizer blocking ring.

11. Lift the front half of reverse idler gear and its thrust washer from case.

12. Remove the main drive gear snap ring (see Figure 4-46), and remove spacer washer.

13. With soft hammer, tap main drive gear down from front bearing as shown in Figure 4-47.

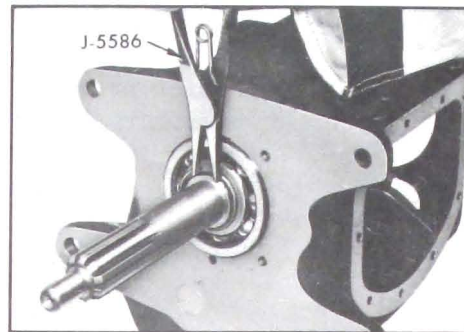

Figure 4-46—Removing Main Drive Gear Snap Ring

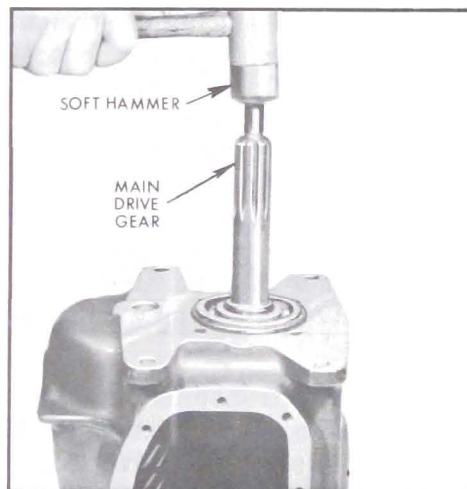

Figure 4-47—Removing Main Drive Gear

14. From inside case, tap out front bearing and snap ring.

15. From the front of the case, remove countershaft (Figure 4-8) with J-9573; then remove the countergear and both tanged washers.

16. Remove the 80 rollers, six .050" spacers and roller spacer from countergear.

17. Remove mainshaft front snap ring (see Figure 4-49), and slide third and fourth speed clutch assembly, third speed gear and synchronizing ring, second and third speed gear thrust washer (needle roller bearing), second speed

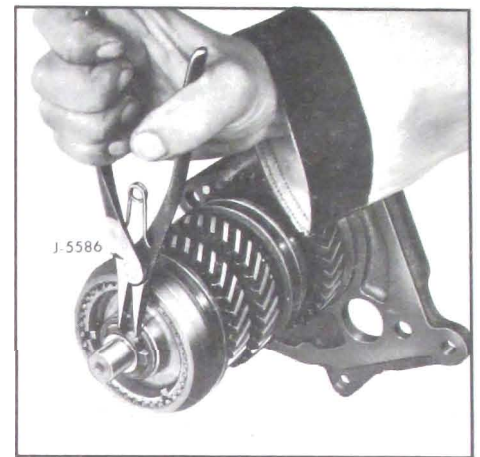

Figure 4-49—Removing Mainshaft Front Snap Ring

gear and second speed synchronizing ring from front of mainshaft.

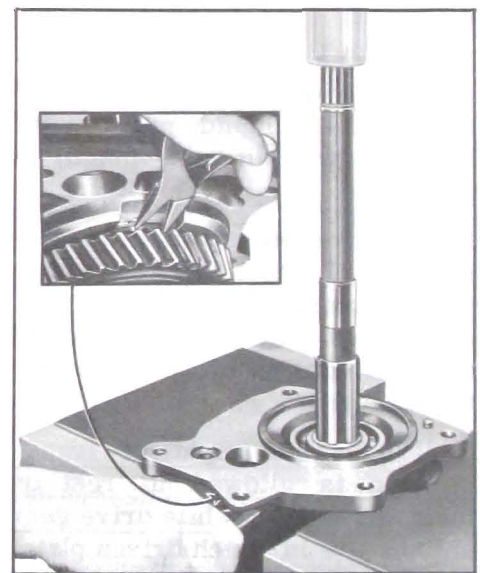
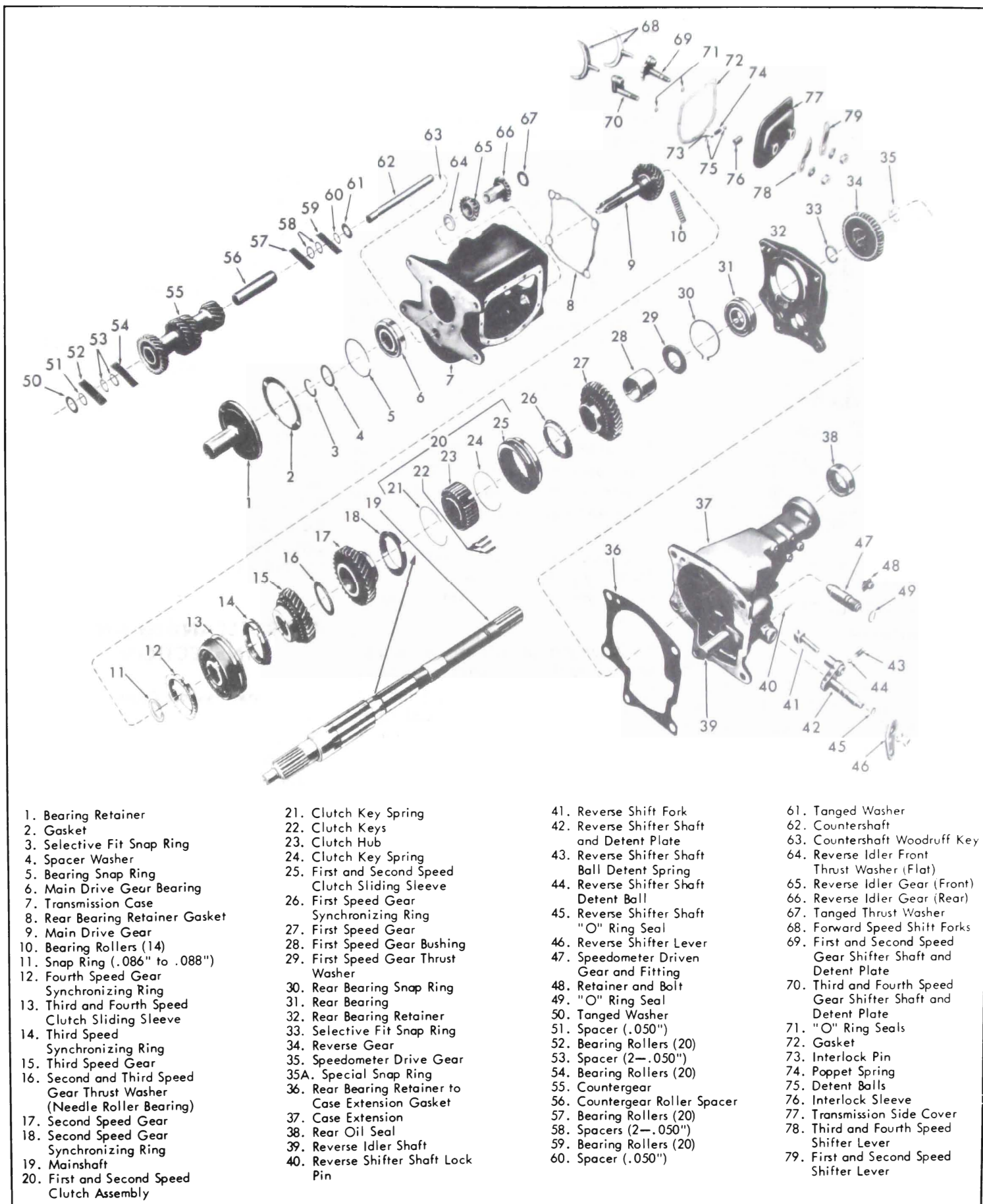

Figure 4-50—Removing Rear Bearing Retainer

18. Spread rear bearing retainer snap ring and press mainshaft out of retainer. See Figure 4-50.

19. Remove the mainshaft rear snap ring. Support first and second speed clutch assembly as shown in Figure 4-50, and press on rear of mainshaft to remove shaft from rear bearing, first speed gear, and synchronizing ring first and second speed clutch sliding sleeve and first speed gear bushing.



- 1. Bearing Retainer
- 2. Gasket
- 3. Selective Fit Snap Ring
- 4. Spacer Washer
- 5. Bearing Snap Ring
- 6. Main Drive Gear Bearing
- 7. Transmission Case
- 8. Rear Bearing Retainer Gasket
- 9. Main Drive Gear
- 10. Bearing Rollers (14)
- 11. Snap Ring (.086" to .088")
- 12. Fourth Speed Gear Synchronizing Ring
- 13. Third and Fourth Speed Clutch Sliding Sleeve
- 14. Third Speed Synchronizing Ring
- 15. Third Speed Gear
- 16. Second and Third Speed Gear Thrust Washer (Needle Roller Bearing)
- 17. Second Speed Gear
- 18. Second Speed Gear Synchronizing Ring
- 19. Mainshaft
- 20. First and Second Speed Clutch Assembly

- 21. Clutch Key Spring
- 22. Clutch Keys
- 23. Clutch Hub
- 24. Clutch Key Spring
- 25. First and Second Speed Clutch Sliding Sleeve
- 26. First Speed Gear Synchronizing Ring
- 27. First Speed Gear
- 28. First Speed Gear Bushing
- 29. First Speed Gear Thrust Washer
- 30. Rear Bearing Snap Ring
- 31. Rear Bearing
- 32. Rear Bearing Retainer
- 33. Selective Fit Snap Ring
- 34. Reverse Gear
- 35. Speedometer Drive Gear
- 35A. Special Snap Ring
- 36. Rear Bearing Retainer to Case Extension Gasket
- 37. Case Extension
- 38. Rear Oil Seal
- 39. Reverse Idler Shaft
- 40. Reverse Shifter Shaft Lock Pin

- 41. Reverse Shift Fork
- 42. Reverse Shifter Shaft and Detent Plate
- 43. Reverse Shifter Shaft Ball Detent Spring
- 44. Reverse Shifter Shaft Detent Ball
- 45. Reverse Shifter Shaft "O" Ring Seal
- 46. Reverse Shifter Lever
- 47. Speedometer Driven Gear and Fitting
- 48. Retainer and Bolt
- 49. "O" Ring Seal
- 50. Tanged Washer
- 51. Spacer (.050")
- 52. Bearing Rollers (20)
- 53. Spacer (2—.050")
- 54. Bearing Rollers (20)
- 55. Countergear
- 56. Countergear Roller Spacer
- 57. Bearing Rollers (20)
- 58. Spacers (2—.050")
- 59. Bearing Rollers (20)
- 60. Spacer (.050")

- 61. Tanged Washer
- 62. Countershaft
- 63. Countershaft Woodruff Key
- 64. Reverse Idler Front Thrust Washer (Flat)
- 65. Reverse Idler Gear (Front)
- 66. Reverse Idler Gear (Rear)
- 67. Tanged Thrust Washer
- 68. Forward Speed Shift Forks
- 69. First and Second Speed Gear Shifter Shaft and Detent Plate
- 70. Third and Fourth Speed Gear Shifter Shaft and Detent Plate
- 71. "O" Ring Seals
- 72. Gasket
- 73. Interlock Pin
- 74. Poppet Spring
- 75. Detent Balls
- 76. Interlock Sleeve
- 77. Transmission Side Cover
- 78. Third and Fourth Speed Shifter Lever
- 79. First and Second Speed Shifter Lever

Figure 4-51

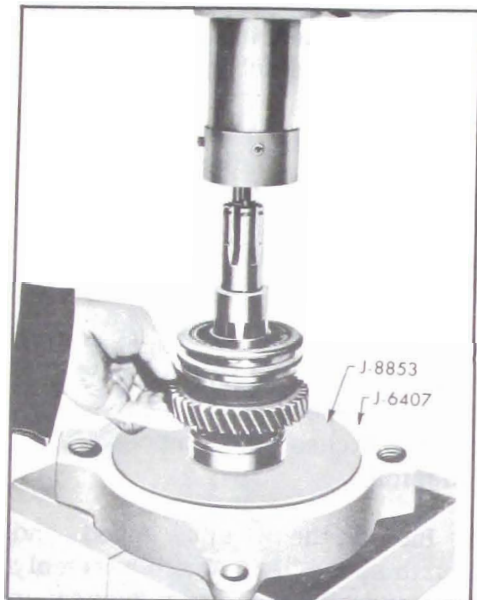

Figure 4-59—Installing Speedometer Drive Gear

snap ring engages the groove in the rear bearing.

12. Install the reverse gear (shift collar to rear).

13. Press speedometer drive gear onto the mainshaft, using a J-8853, press plate. (See Figure 4-59). Position the speedometer gear to get a measurement of 4-1/2" from the center of the gear to the flat surface of the rear bearing retainer. (See Figure 4-60).

14. Replace rear bearing snap ring on mainshaft.

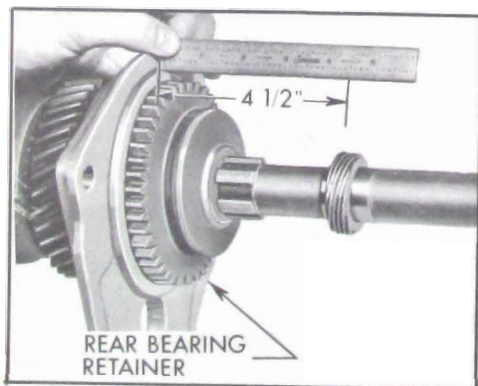

Figure 4-60—Speedometer Gear Location

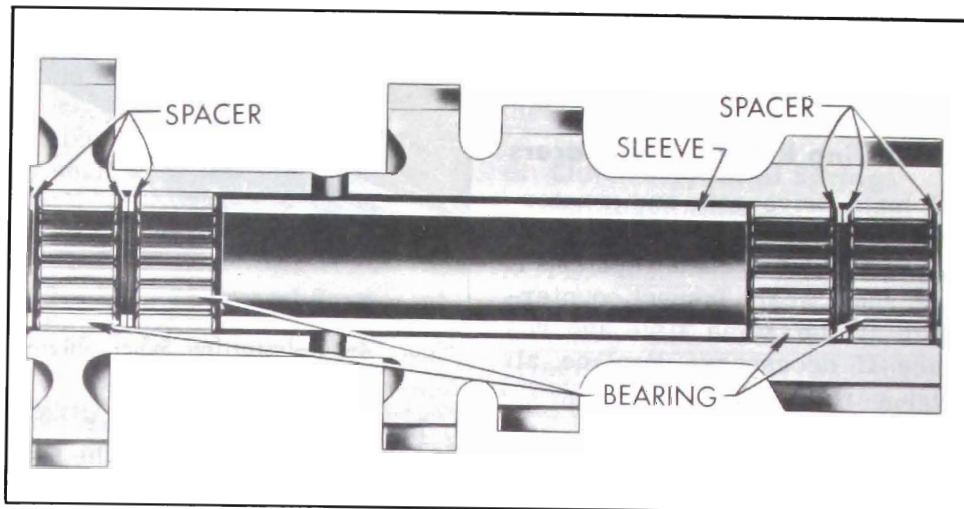

Figure 4-61—Counter Gear Assembly

b. Counter Gear Assembly

1. Install roller spacer in counter gear.

2. Using heavy grease to retain the rollers, install 20 rollers in either end of the counter gear, two .050" spacers, 20 more rollers, then one .050" spacer. Install in the other end of the counter gear, 20 rollers, two .050" spacers, 20 more rollers, and another .050" spacer. (See Figure 4-62).

c. Transmission Assembly

1. Rest the transmission case on

its side with the side cover opening toward the assembler. Reinstall retainer thrust washers on end of counter gear with grease.

2. Set counter gear in place in bottom of transmission case, making sure that tanged thrust washers are correctly positioned.

3. Press bearing onto main drive gear (snap ring groove to front), using J-5746 (Figure 4-62). Be sure bearing fully seats against shoulder on gear.

4. Install spacer washer and selective fit snap ring in groove on gear stem.

NOTE: The snap ring is available in three thicknesses: .087", .093", and .099". Use the ring that will produce from zero to .005" clearance between the rear face of the snap ring and the front face of the spacer washer.

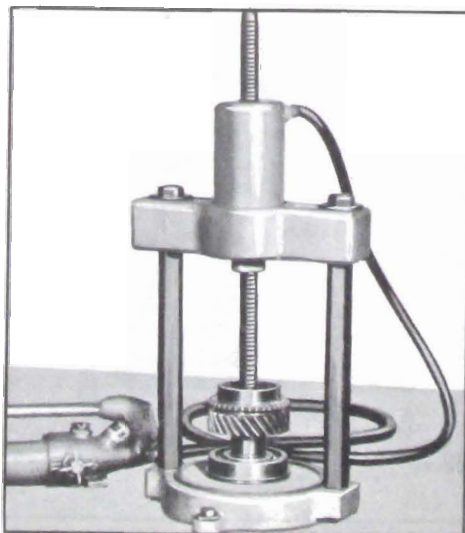

Figure 4-62—Installing Main Drive Gear Bearing

5. Install the main drive gear and bearing assembly through the side cover opening and into position in transmission front bore. Tap lightly into place, if necessary, with a plastic hammer. Place snap ring and spacer in groove in front bearing.

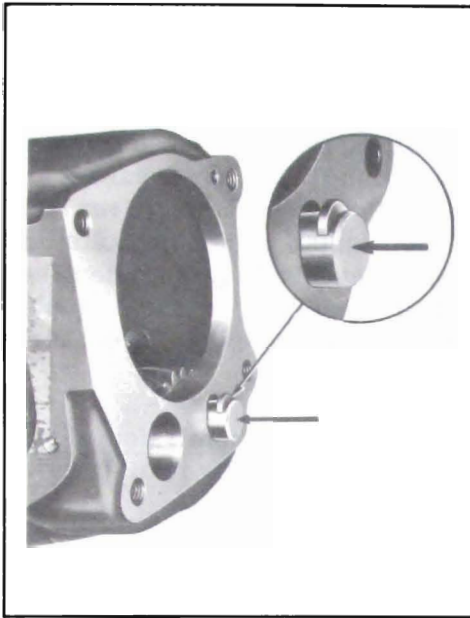

Figure 4-63—Installing Countershaft

6. With the transmission case resting on its front face, move countergear into mesh with main drive gear. Be sure thrust washers remain in place. Install woodruff key into end of countershaft and press shaft (Figure 4-63) until end of shaft is flush with rear face of transmission case.

7. Attach a dial indicator as shown in Figure 4-64, and check the end play of the countergear. End play must not be more than .025".

8. Install the fourteen roller bearings into the main drive gear, using heavy grease to hold the bearing in place.

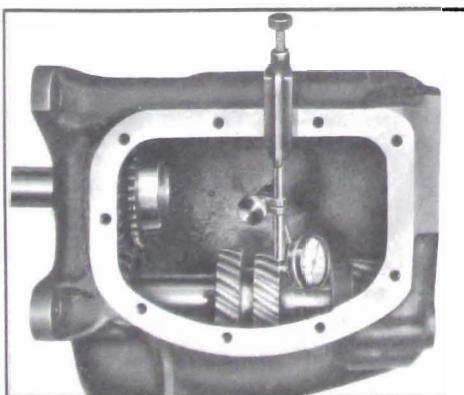

Figure 4-64—Checking Countergear End Play

9. Using heavy grease, place gasket in position on front face of rear bearing retainer.

10. Install fourth speed synchronizing ring on main drive gear with the notches toward the rear of the transmission.

11. Position the reverse idler gear thrust washer (untanged) on the machined face of the ear cast for the reverse idler shaft. Position the front reverse idler gear on top of the thrust washer, with the hub facing forward rear of the case.

12. Lower the mainshaft assembly into the case, making certain that the notches on the fourth speed synchronizing ring correspond to the keys in the clutch assembly. See Figure 4-65.

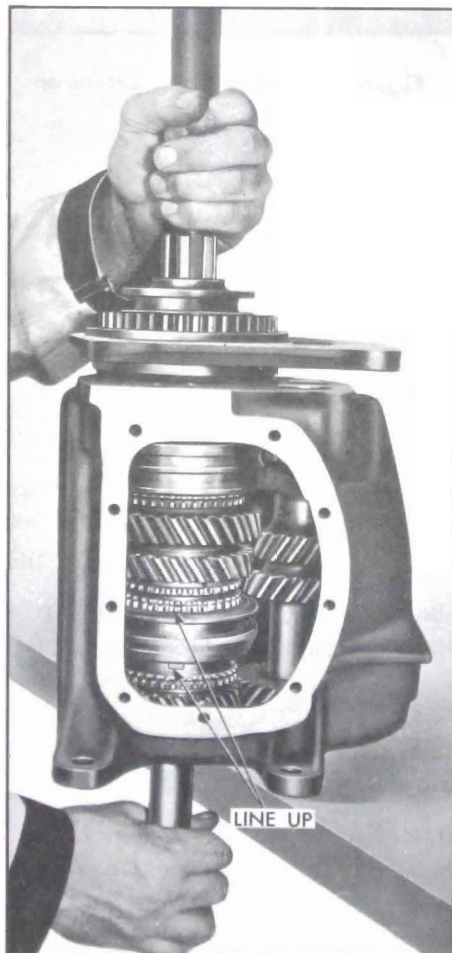

Figure 4-65—Installing Mainshaft

13. Install the self-locking bolt attaching rear bearing retainer to transmission case. Torque to 20 to 30 ft. lbs.

14. From the rear of the case, insert the rear reverse idler gear, engaging the splines with the portion of the gear, within the case.

15. Using heavy grease, place gasket into position on rear face of rear bearing retainer.

16. Using heavy grease, install the remaining thrust washer into place on the reverse idler shaft, making sure tang on the thrust washer is in the notch in the idler thrust face of the extension.

17. Place the two clutches in neutral position. Pull reverse shifter shaft to left side of extension and rotate shaft to bring reverse shift fork as far forward in extension as possible. Start the extension onto the transmission case (Figure 4-68) while slowly pushing in on the shifter shaft to engage the shift fork with the reverse gear shift collar. When the fork engages, rotate the shifter shaft to move the reverse gear rearward, permitting the extension to slide onto the transmission case.

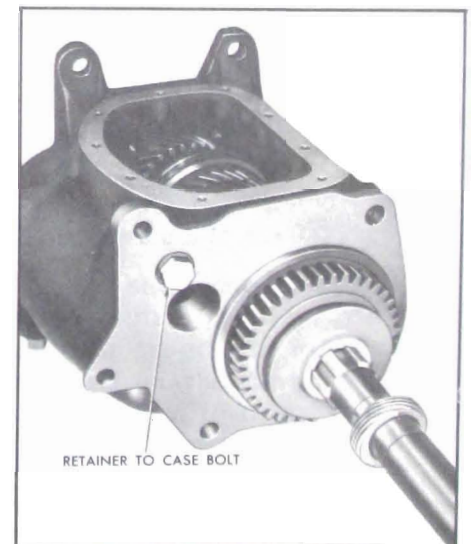

Figure 4-66—Bearing Retainer To Transmission Bolt

18. Install new oil seal in rear bearing retainer, using Seal Installer J-8864. See Figure 4-67. Lightly coat seal with gear lubricant.

19. Install three extension and retainer to case attaching bolts



Figure 4-67—Installing Extension Oil Seal

(torque to 35 to 45 ft. lbs.) and two extension to retainer attaching bolts (torque to 20 to 30 ft.

20. Push or pull reverse shifter shaft to line up groove in the shaft with the holes in the boss and drive in the lock pin. Install shifter lever.

21. Install the main drive gear bearing retainer, gasket and four attaching bolts, using a suitable sealer on bolts. Torque to 15 to 20 ft. lbs.

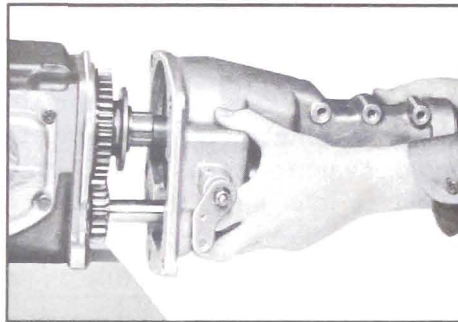

Figure 4-68—Installing Extension To Case

22. Install a shift fork in each clutch sleeve.

23. Place both clutches in neutral, install side cover gasket and carefully lower side cover into place. Install attaching bolts and tighten evenly to avoid side cover distortion. Use suitable sealer when installing the lower right bolt.

NOTE: The transmission should "overshift" slightly in all ranges.

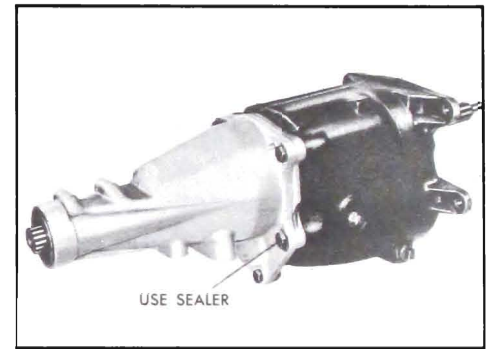

Figure 4-69—Sealing Case Extension Attaching Bolt