

SECTION 2-F

COOLING AND OILING SYSTEMS SERVICE

CONTENTS OF SECTION 2-F

| Paragraph | Subject | Page | Paragraph | Subject | Page |
|-----------|--|------|-----------|-------------------------------|------|
| 2-19 | Cooling System Services | 2-33 | 2-21 | Radiator Thermostat | |
| 2-20 | Fan Belt Adjustment or Replacement | 2-35 | | Inspection and Test | 2-36 |
| | | | 2-22 | Water Pump Repairs | 2-37 |
| | | | 2-23 | Oil Pump Repairs | 2-37 |

2-19 COOLING SYSTEM SERVICES

a. Checking and Filling Cooling System

The coolant level should be checked only when the engine is cold and only enough coolant should be added to bring the level to the tip of the "FILL COLD" arrow.

It is unnecessary and undesirable to remove the radiator cap and check the coolant level each time the car stops at a filling station for gasoline or oil, since the engine is usually hot at such times.

CAUTION: Never remove the radiator cap quickly when engine is HOT. Sudden release of cooling system pressure may cause the coolant to boil and some of it may be ejected from the radiator filler neck, resulting in injury to persons or damage to the car finish.

If it is necessary at any time to remove the radiator cap when engine is hot, rotate the cap counterclockwise until a stop is reached. Leave cap in this position until all pressure in cooling system has been released, then turn cap forcibly past the stop and remove it.

b. Draining, Flushing, Conditioning Cooling System

The cooling system should be completely drained and the rec-

ommended coolant installed every two (2) years.

To drain the cooling system, remove radiator cap, open the drain cock in the lower radiator tank and remove drain plugs on both sides of cylinder block. If car is heater equipped, set heater temperature control valve at full heat position.

After the cooling system is drained, plugs reinstalled and cock closed, fill the system with clean water. Run the engine long enough to open the thermostat for complete circulation through the system, then completely drain the cooling system before sediment has a chance to settle.

c. Conditioning the Cooling System

"Rust Inhibitor and Stop Leak", listed under Group 8.800 is recommended for use in the cooling system, particularly when preparing for installation of anti-freeze solution. This material stops small seepage leaks, has rust preventive properties and its soluble oil is effective in eliminating a squealing noise which sometimes develops at the water pump seal washer. Instructions for its application are printed on the conditioner bottle.

It is very important to make certain that the cooling system is properly prepared before an anti-freeze solution is installed;

otherwise, loss of solution through leakage may occur or seepage may result in damage to the engine. The cooling system should be drained and flushed as described above (subpar. b.), all joints should be checked for leakage and corrected, and the conditioner described above should be added with the anti-freeze solution.

Inspect the water pump, radiator core, heater and defroster cores, drain cocks, water jacket plugs, and edge of cylinder head gaskets for evidence of water leaks. Tighten all hose clamps in the cooling and heating systems and replace any deteriorated hoses.

d. Using and Testing Anti-Freeze Solutions

Inhibited year around (permanent type) engine coolant solution which is formulated to withstand two full calendar years of normal operation without draining or adding inhibitors should be used at all times. Freeze protection should be provided to protect against corrosion. When adding solution due to loss of coolant for any reason or in areas where temperatures lower than -20°F. may be encountered, a sufficient amount of any of the several brands of year around coolant (Ethylene Glycol base) compatible to GM Specification 1899-M available on the market should be used.

2-34 COOLING SYSTEM

NOTE: Alcohol base coolants are not recommended for this vehicle at any time.

If for any reason water only is used as a coolant in an emergency, it is extremely important that Buick Heavy Duty Cooling System Protector and Water Pump Lubricant be added to the cooling system as soon as possible. This material is available at your Buick dealer under Part #980504. If any other cooling system protector is used, be certain it is labeled to indicate that it

meets General Motors Specification GM 1894-M. It should be recognized that this is only a temporary measure. The manufacturer intends that permanent type coolant solution be used year around in the cooling system of your Buick.

The cooling system should be completely drained and the recommended coolant installed every two (2) years.

It is advisable to test the anti-freeze solution at intervals during the winter to make certain that

the solution has not been weakened by evaporation or leakage. Use only hydrometers which are calibrated to read both the specific gravity and the temperature, and have a table or other means of converting the freezing point at various temperatures of the solution. Disregarding the temperature of the solution when making the test may cause an error as large as 30°F. Care must be exercised to use the correct float or table for the particular type of anti-freeze being tested.

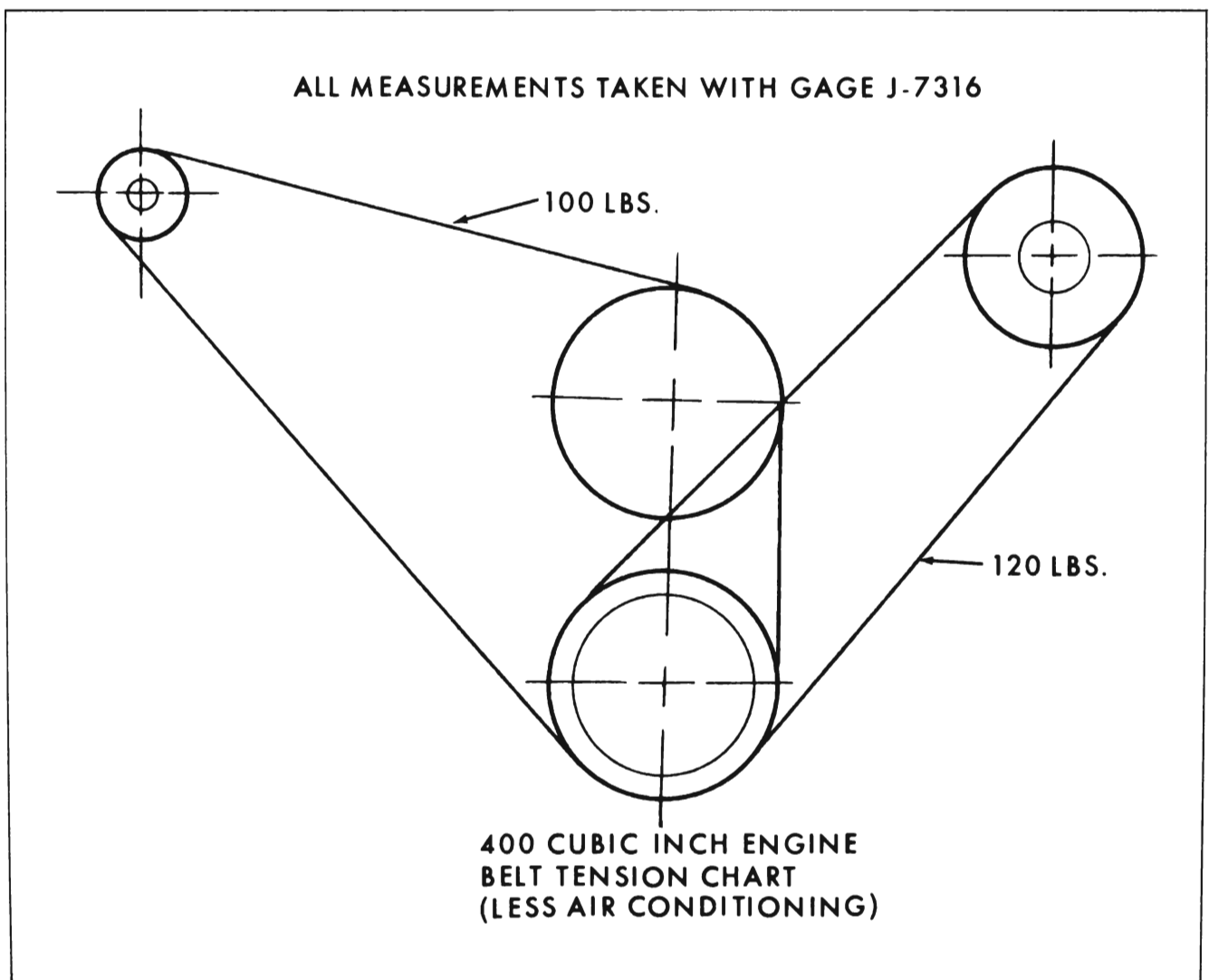

Figure 2-35—Belt Tension Chart - Air Conditioned Jobs

2-20 FAN BELT ADJUSTMENT OR REPLACEMENT

A tight fan belt will cause rapid wear of the generator and water pump bearings. A loose belt will slip and wear excessively and will cause noise, engine overheating, and unsteady generator output. A fan belt which is cracked or frayed, or which is worn so that it bottoms in the pulleys should be replaced.

The fan belt may be replaced by loosening the generator brace at both ends, slightly loosening the generator mounting bolts and moving generator inward to provide maximum slack in the belt. On a car equipped with power steering, it is also necessary to remove the oil pump drive belt after loosening the pump mounting bolts.

The Delcotron generator must be moved sidewise to adjust the fan

belt. After the Delcotron generator brace and mounting bolts are securely tightened, the fan belt tension should be checked as shown in Figures 2-35 and 2-36.

If the power steering oil pump belt is removed it should be adjusted as shown in Figures 2-35 and 2-36.

If the Air Conditioner compressor belts are removed they should be adjusted as shown in Figures 2-35 and 2-36.

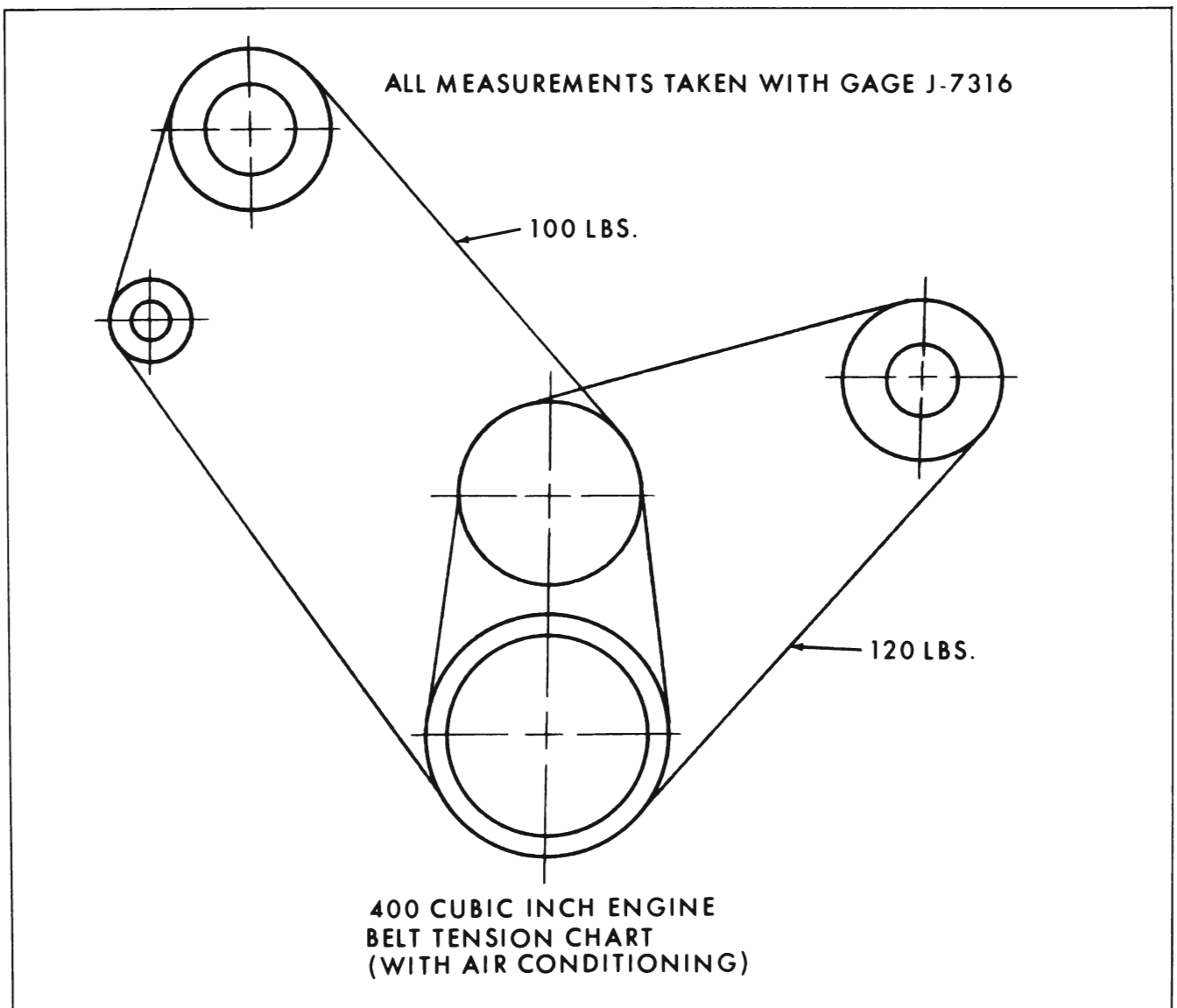

Figure 2-36—Belt Tension Chart - Non Air Conditioned Jobs

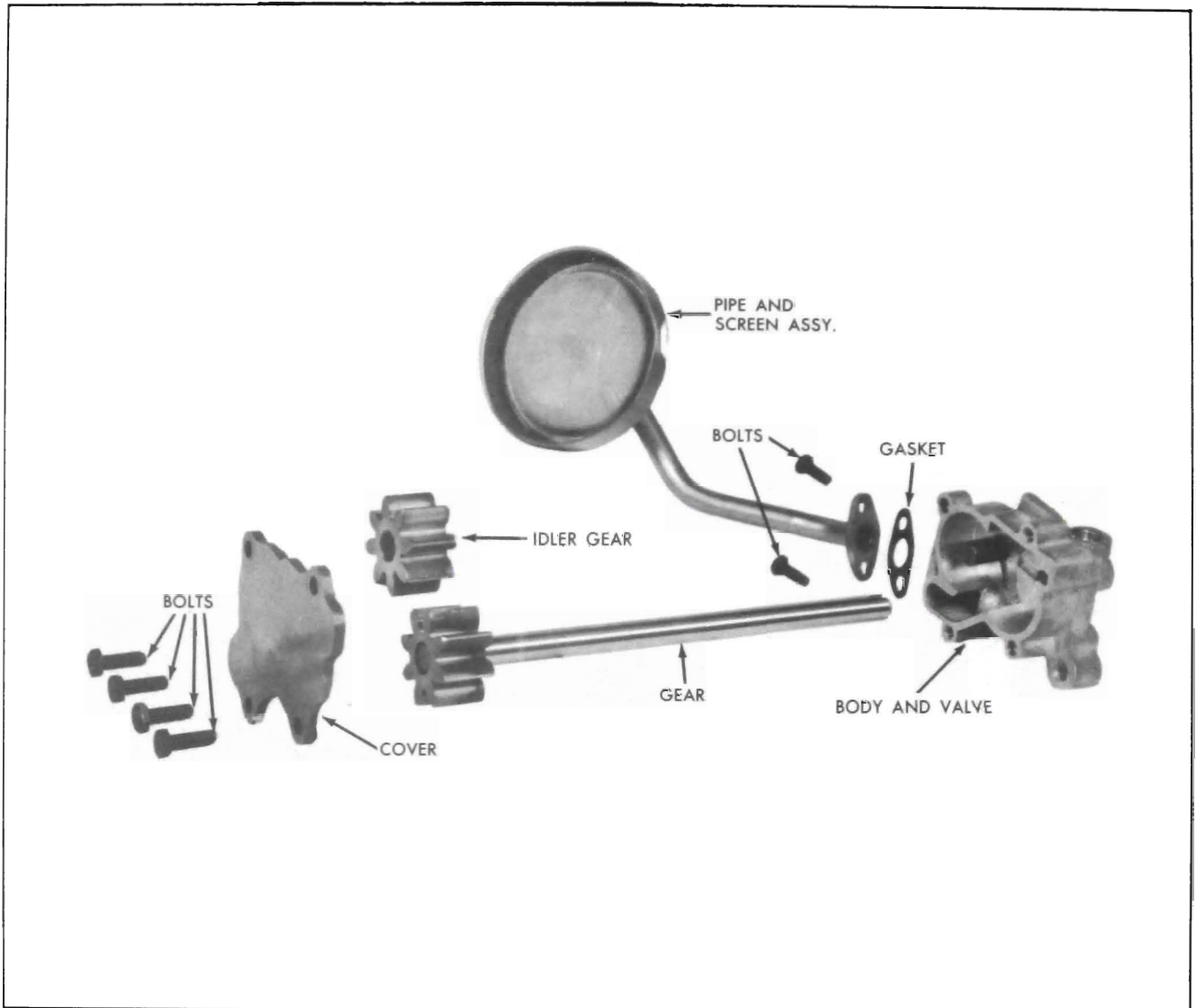

Figure 2-37—Oil Pump Exploded View

2-21 RADIATOR THERMOSTAT INSPECTION AND TEST

A sticking radiator thermostat will prevent the cooling system from functioning properly. If the thermostat sticks in the open position, the engine will warm up very slowly. If the thermostat sticks in the closed position, overheating will result.

The thermostat may be removed

for inspection and test by partially draining the cooling system and disconnecting the water outlet and hose from the water manifold, in which the thermostat is located.

If the thermostat valve does not fully close when cold, replace the thermostat. If the valve will fully close when cold, test the thermostat for correct opening temperature by immersing the unit and a thermometer in a container of water over a heater. While heating the water do not rest

either the thermometer or thermostat on bottom of container as this will cause them to be at higher temperature than the water. Agitate the water to insure uniform temperature of water, thermostat and thermometer.

The standard thermostat (180°) valve should start to open at a temperature of 177°F. to 182°F., and should be fully open at a temperature not in excess of 202°F. If thermostat does not operate at specified temperatures it should be replaced as it cannot be adjusted.

2-22 WATER PUMP REPAIRS

The water pump cover is die cast aluminum into which the water pump bearings are shrunk fit. For this reason the pump cannot be disassembled and is serviced as a unit.

a. Removal

1. Drain cooling system being sure to drain into a clean container if anti-freeze solution is to be saved.

2. Loosen belt or belts, then remove fan blade, spacer and pulley or pulleys from hub on water pump shaft. Remove belt or belts.

3. Disconnect hose from water pump inlet and heater hose from nipple. Remove bolts then remove pump assembly and gasket from timing chain cover.

4. Check pump shaft bearings for end play or roughness in operation. If bearings are not in serviceable condition, the assembly must be replaced.

b. Installation

1. Make sure the gasket surfaces on pump and timing chain covers are clean. Install pump assembly with new gasket. Bolts with lock washers must be tightened uniformly.

2. Connect radiator hose to pump inlet and heater hose to nipple,

then fill cooling system and check for leaks at pump and hose joints.

3. Install fan pulley or pulleys, spacer and fan blade, tighten attaching bolts securely. Install belt or belts and adjust for proper tension. See Figures 2-35 and 2-36.

2-23 OIL PUMP REPAIRS

When an oil pump is removed for repairs the following procedure must be used to inspect parts and assemble pump in order to insure adequate oil pressure when the work is completed.

1. Remove pipe and screen assembly.

2. Remove cover. Slide gears out of body.

3. Wash all parts in solvent and blow dry with air hose.

4. Inspect body, cover gears and shaft for evidence of wear, scoring, etc. Replace any parts not found serviceable.

5. Install gear and shaft and idler gear in pump body.

6. Check for clearance between gears and cover by using a straight edge as shown in Figure 2-38.

7. Clearance should be not more than .005" or less than .0005".

8. Pack cavity and space between

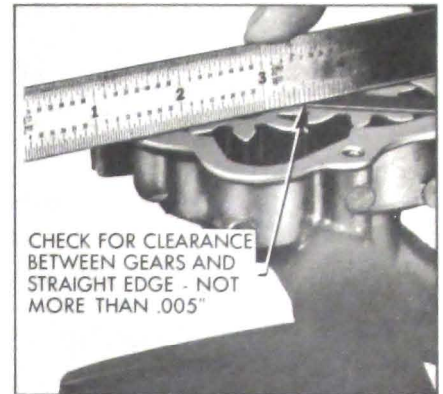

Figure 2-38—Checking Clearance of Gears at Cover

gears and body with petroleum jelly. Do not use chassis lube.

9. Install pump cover (side with groove toward gears).

10. Tighten bolts to 6-8 ft. lbs. torque.

11. Use new gasket and install pipe and screen to body. Tighten bolts to 6-8 ft. lbs. torque.

12. Before installation of pump be sure surface of crankcase is free of dirt or burrs that might tilt the pump and cause a bind.

13. Install oil pump with new gasket. Tighten bolts a little at a time while turning pump shaft through gear lash. If pump shaft tends to bind when bolts are tightened, it may be freed up by rapping body with mallet. Pump shaft must be free of bind when bolts are tightened. Torque bolts to 30 ft. lbs.