

## SECTION 4

# HEADLINING

### INDEX

Subject	Page	Subject	Page
Headlining - Cloth and Vinyl Coated - All Styles		Headlining - "55 and 65" Station Wagon Styles . . .	
Except "55 - 65" Station Wagon Styles . . . . .	4-1	Description . . . . .	4-6
Description . . . . .	4-1	Front Headlining . . . . .	4-6
Removal of Headlining . . . . .	4-1	Removal . . . . .	4-6
Installation of Headlining . . . . .	4-4	Installation . . . . .	4-8
Headlining - Polyurethane Foam and Flocked . . .	4-4	Rear Headlining . . . . .	4-8
Description . . . . .	4-4	Removal . . . . .	4-8
Removal of Headlining . . . . .	4-4	Installation . . . . .	4-8
Installation of Headlining . . . . .	4-4		

## HEADLINING—CLOTH AND VINYL COATED ALL STYLES—EXCEPT "55 AND 65" STATION WAGONS

### DESCRIPTION

The headlining assembly is formed to the contour of the roof panel by concealed listing wires. The listing wires are retained to the headlining by listing wire pockets which are part of the headlining assembly.

Depending upon the body type and style, the listing wires are attached to the side roof rails by either inserting wires directly into holes in side rail or into a clip which is screwed into the side rail. (See View "A and B" in Fig. 4-1.)

On all styles except Corvair equipped with a vinyl coated headlining, the listing wires are further attached to the roof panel by tabs on the front to rear longitudinal roof bow. (See View "D" in Fig. 4-1.)

When pinchweld finishing lace is used at the windshield and back window or back body opening, the headlining is attached by means of cement at those areas.

Where garnish moldings are utilized the headlining is tacked or stapled in addition to being cemented at the windshield and back window or back body opening (View "E", Fig. 2155 and Fig. 4-2).

The headlining is retained along the side roof rails by cementing or the use of a pronged retainer. Depending upon the style, garnish moldings or pinchweld finishing lace is also used to assist in retaining the headlining. The side roof rail garnish moldings are secured to the pinchweld flange by clips that are located in the molding. (See Figs. 4-3 and 4-4.)

On styles where an upper quarter trim panel is utilized, the headlining is tacked or stapled to a

trim stick in the roof extension area (See Fig. 4-2). The upper quarter trim is retained by clips (See Fig. 4-2). On "E" Body Styles the upper quarter trim is further retained by cementing the forward edge to the side roof rail. On styles where the headlining covers the entire roof extension area, the headlining is retained along the rear compartment shelf by a pronged retainer (See Fig. 4-5).

### REMOVAL

1. Place protective coverings over seat cushions and backs.
2. Prior to removing headlining, remove following hardware and trim assemblies if present.
  - a. Windshield side and upper garnish moldings or finishing lace.
  - b. Rear view mirror support.
  - c. Sun shade supports.
  - d. Dome or rear quarter courtesy lamps.
  - e. Coat hooks.
  - f. Side roof rail moldings or finishing lace.
  - g. Back window garnish moldings or finishing lace.
  - h. Center pillar finishing moldings.
  - i. Rear quarter trim, where necessary.
  - j. Upper quarter trim finishing panel (on styles so equipped).

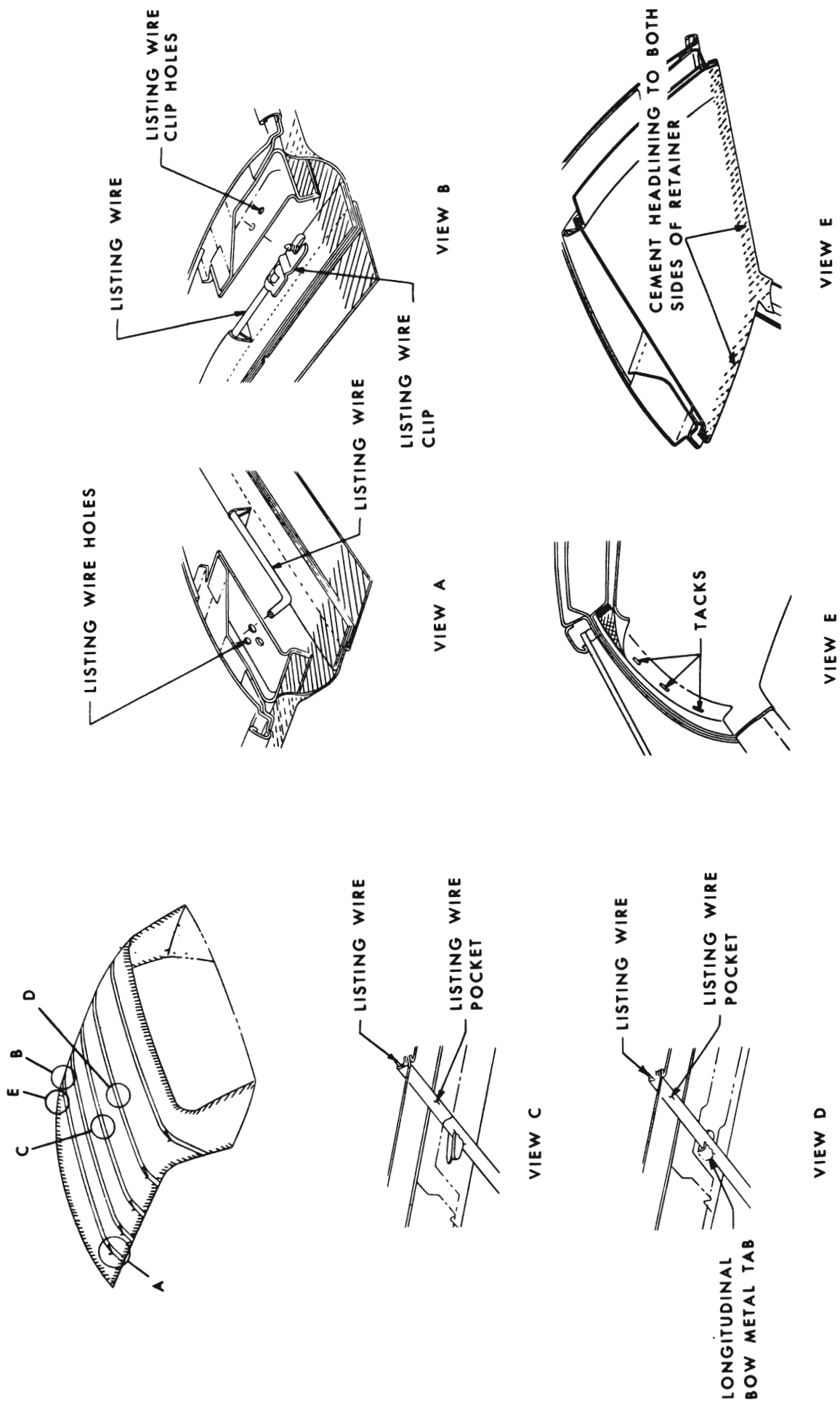

Fig. 4-1—Vinyl and Cloth Headlining Installation

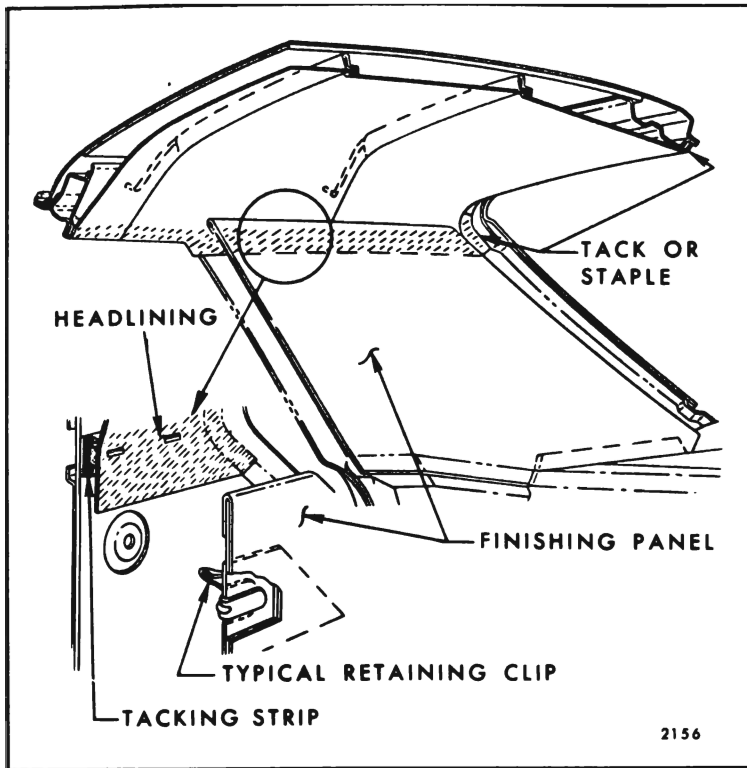

Fig. 4-2—Upper Quarter Trim Installation

k. Back body opening garnish moldings or finishing lace.

3. Carefully remove tacks or staples securing headlining at windshield and back window opening or back body opening.
4. On styles using pronged retainers, use headlining inserting tool, J-2772 or similar wide-bladed tool and carefully disengage headlining from pronged retainers where present.
5. Carefully detach cemented edge of headlining around entire perimeter.
6. Starting at front of body, carefully disengage No. 1 and No. 2 listing wires from side roof

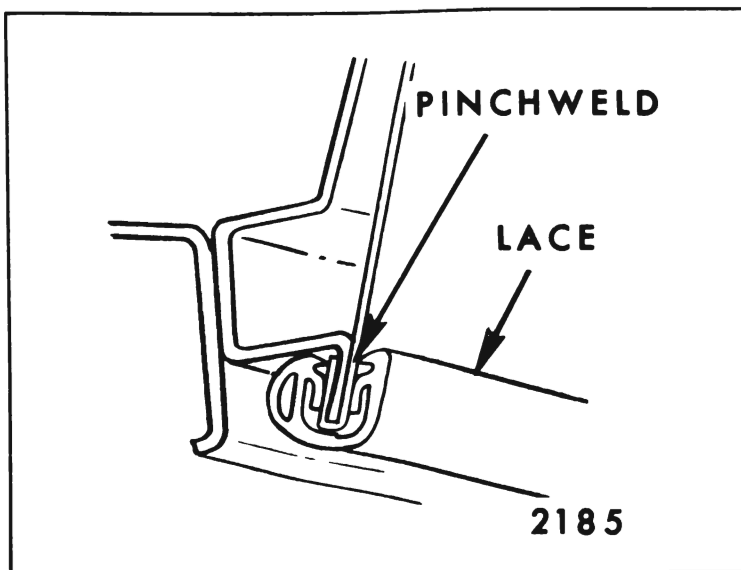

Fig. 4-3—Pinchweld Finishing Lace

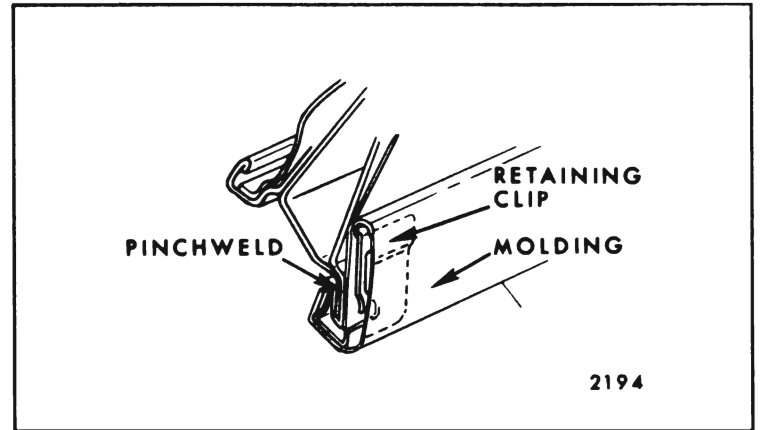

Fig. 4-4—Side Roof Rail Garnish Moldings

inner rails and supporting tabs on longitudinal (front to rear) bow on styles so equipped (View "D" in Fig. 4-1). In like manner, working from rear of body, disengage listing wires from side roof rails and supporting tabs on longitudinal bow. Exercise care to keep headlining material clean by gathering or folding headlining with listing wires on outside.

7. At No. 3 listing wire, bend down tab securing listing wire (View "C" in Fig. 4-1) and remove headlining assembly from body.

**IMPORTANT:** Note in which holes listing wires are installed in side roof rails. Listing wires should be placed in same hole when replacing headlining.

8. If replacing headlining, remove listing wires from pockets of old headlining.

**IMPORTANT:** Listing wires removed from old headlining must be installed in corresponding pockets of new headlining.

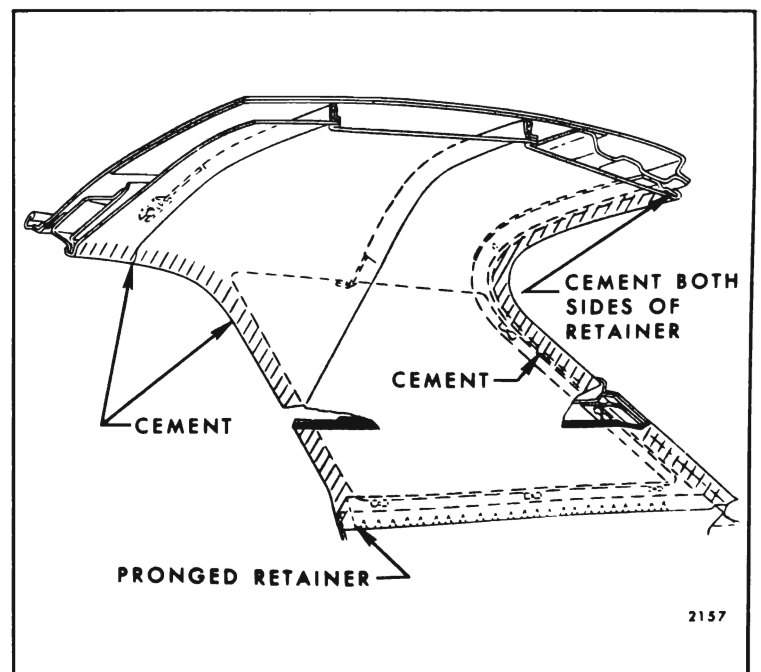

Fig. 4-5—Headlining Installation at Roof Extension

## INSTALLATION

1. If previously removed, install listing wires into corresponding pockets of new headlining assembly.
2. Apply approved trim cement to headlining attaching surface at windshield, side roof rail and back window or back body opening. On styles that utilize pinchweld finishing lace be certain cement is applied to both sides of retainer at windshield and back window or back body opening. (View "E", Fig. 4-1 and Fig. 4-5)
3. Lift headlining assembly into body and install No. 3 listing wire and listing wire pocket over metal tab at roof bow (View "C", Fig. 4-1). Bend up tab to secure listing wire to bow. Make certain headlining is centered in body.
4. When new headlining is being installed on styles equipped with longitudinal bow (except

cloth headlining) slit listing wire pockets at each tab location on longitudinal bow (approximately 1-1/2" in length). Working rearward from No. 3 listing wire, install listing wires in side roof rails and over tabs on longitudinal bow. In like manner, working forward, install No. 2 and No. 1 listing wires. (View "D", Fig. 4-1)

**NOTE:** Listing wires may be adjusted up or down by utilizing appropriate holes in side roof rails. Listing wires should rest tight against roof panel after installation. (Views "A" and "B" in Fig. 4-1)

5. Stretch and secure headlining at windshield and back window or back body opening. Stretch and secure headlining at rear quarters and side roof rails. Permanently attach material removing draws and wrinkles and replace all previously removed inside hardware and trim assemblies.

## HEADLINING—POLYURETHANE FOAM AND FLOCKED HEADLININGS

### DESCRIPTION

The polyurethane foam headlining assembly and the flocked headlining assembly consist of five individual sections.

The headlining sections are secured in place by retainers formed to the contour of the roof panel. Plastic moldings are snapped over the retainers and cover the retainers and edges of the headlining sections. Windshield, back window and side roof rail garnish moldings, also assist in holding the headlining in place.

When necessary, the headlining sections may be individually removed and replaced.

### REMOVAL (ONE OR MORE SECTIONS)

1. Place protective coverings over seat cushions and backs.
2. Remove side roof rail moldings. If removing front section of headlining, remove windshield upper and side garnish moldings, sunshade support assemblies and rear view mirror support. If removing rear section, remove back window garnish moldings, side roof rail garnish moldings and rear quarter trim assembly to gain access to headlining at side roof rail area. If center sections are removed, where required, remove dome lamps, coat hooks, and coat hook spacers if present.

3. With flat-bladed tool, carefully pry one end of plastic molding from retainer and remove (View "C", Fig. 4-6). Remove plastic moldings from both retainers securing section of headlining being removed.
4. When removing individual sections, use flat-bladed tool and carefully pry one edge of headlining section from retainer and remove from body.
5. If removing headlining section at back window, remove tacks or staples securing section at back window opening.
6. When retainers are required to be removed, remove screws securing retainer to roof (View "D", Fig. 4-6). Retainer spacers are installed between the metal retainers and roof (View "D", Fig. 4-6).

### INSTALLATION:

1. If retainers were removed, make certain that retainer spacer shown in View "D", of Figure 4-6 is installed prior to installing retainers.

**NOTE:** Retainers should be tight against roof panel after installation.

2. Install headlining sections by positioning one edge in retainer and centering section in relation to other sections and side roof rails;

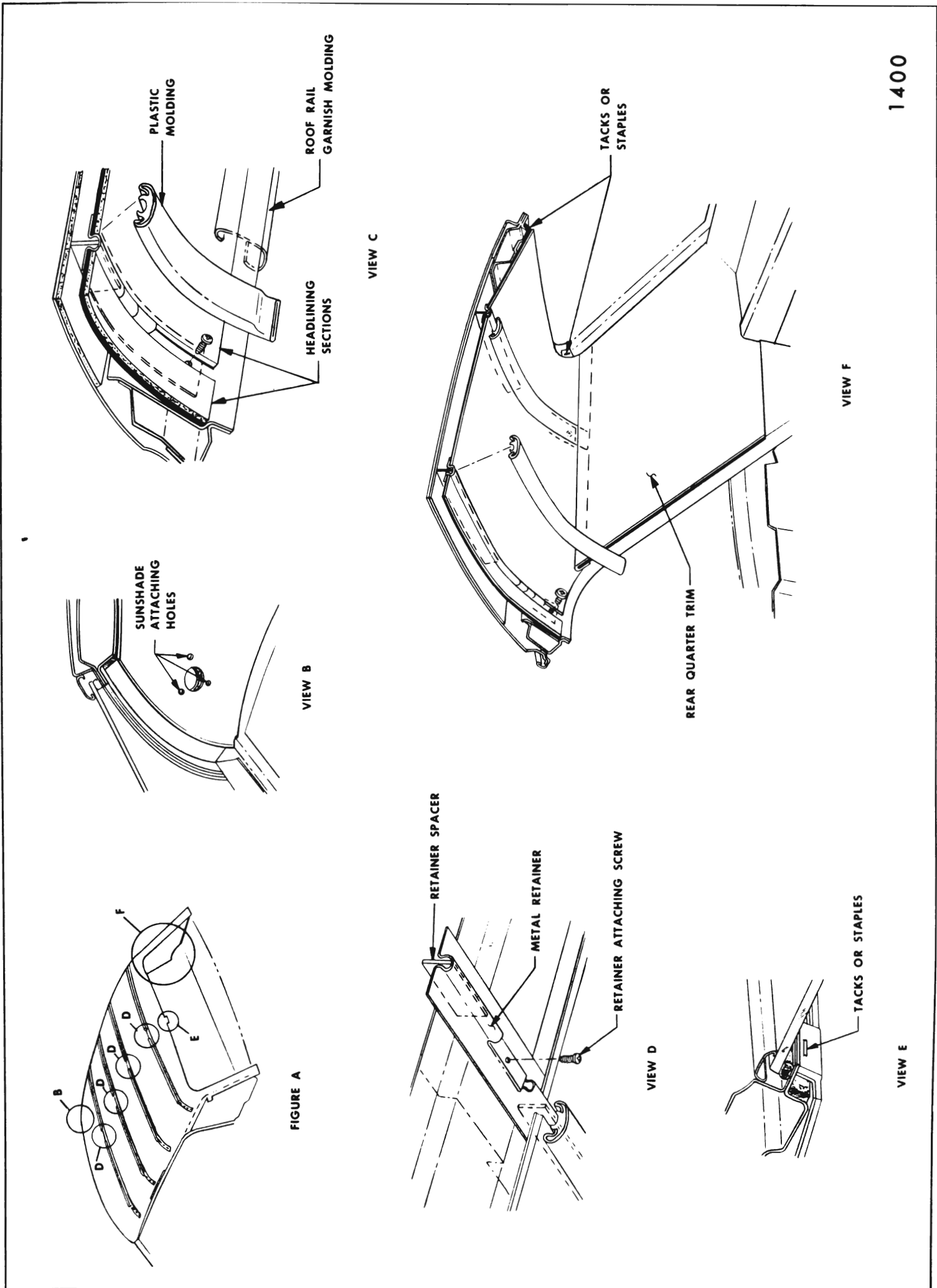

Fig. 4-6—Polyurethane Foam Headlining and Flocked Headlining Installation

then carefully snap remaining edge in other retainer. Snap plastic molding over retainers (View "C", Fig. 4-6).

3. If installing rear section of headlining assembly, position forward edge of section in retainer. Center and align section in relation to side roof rails and back window opening and stay tack section in place. Recheck alignment; then starting at center of back window area, permanently tack section to tacking strips at back window opening (View "F", Fig. 4-6).
4. If installing front section of headlining assembly, position appropriate edge in retainer. Center headlining section in relation to other

sections, side roof rails, and sunshade support attaching holes (View "B", Fig. 4-6). Install sunshade supports.

**NOTE:** Forward edge of front section and rearward edge of rear section are also secured in place by windshield or back window garnish moldings.

5. Install all previously removed hardware and remove protective coverings.

**NOTE:** When installing side roof rail moldings, make certain edge of headlining section is covered by side roof rail moldings.

## HEADLINING—"55 AND 65" STATION WAGON STYLES

### DESCRIPTION

The "55 and 65" station wagon styles use two separate headlining assemblies and may be removed and replaced separately.

The front headlining is formed to the contour of the roof panel by concealed listing wires (View "A", Fig. 4-7). The ends of the listing wires are installed into holes in the side roof inner rails (View "B"), and may be adjusted up and down or fore and aft.

The headlining material is cemented to metal retainers and side roof rail pinchweld flanges (View "B", "C" and "D", Fig. 4-7). Escutcheons, moldings, and finishing lace cover the edges and assist in holding the material in place.

The rear headlining is formed to the contour of the roof panel by concealed listing wires (View "E", Fig. 4-7). The ends of the listing wires are installed into clips which are secured to the side roof inner rails by screws (View "F", Fig. 4-7). The edges of the material are cemented to the retainer flanges (View "G", Fig. 4-7). Finishing lace and moldings cover the edges and assist in holding the material in place.

**CAUTION:** Clean hands are essential when working with headlining material.

### FRONT HEADLINING ASSEMBLY

#### Removal

1. Place protective covers over front seat cushion and back.
2. Prior to removal of the front headlining, remove the following items:

- a. Sunshade supports.
- b. Rear view mirror support.
- c. Windshield upper corner escutcheons.
- d. Center lock pillar upper finishing plates.
- e. Side skylight front upper garnish molding.
- f. Coat hooks.
- g. Courtesy lamps.
- h. Front skylight center division garnish molding.
- i. Front headlining finishing lace.
- j. Rear of headlining finishing lace.
- k. Finishing lace over front and rear doors.

3. Starting at front, carefully detach all cemented edges of headlining material from retainers and flanges.

4. Bend down tab at front listing wire (View "H", Fig. 4-7); remove listing wires from inner rails. Gather or roll headlining with listing wires on outside to keep headlining clean and remove old headlining assembly.

**IMPORTANT:** Note into which holes ends of listing wires are installed in side roof rails. Listing wires should be placed in same holes when replacing headlining. If replacing headlining remove listing wires from pockets of old headlining.

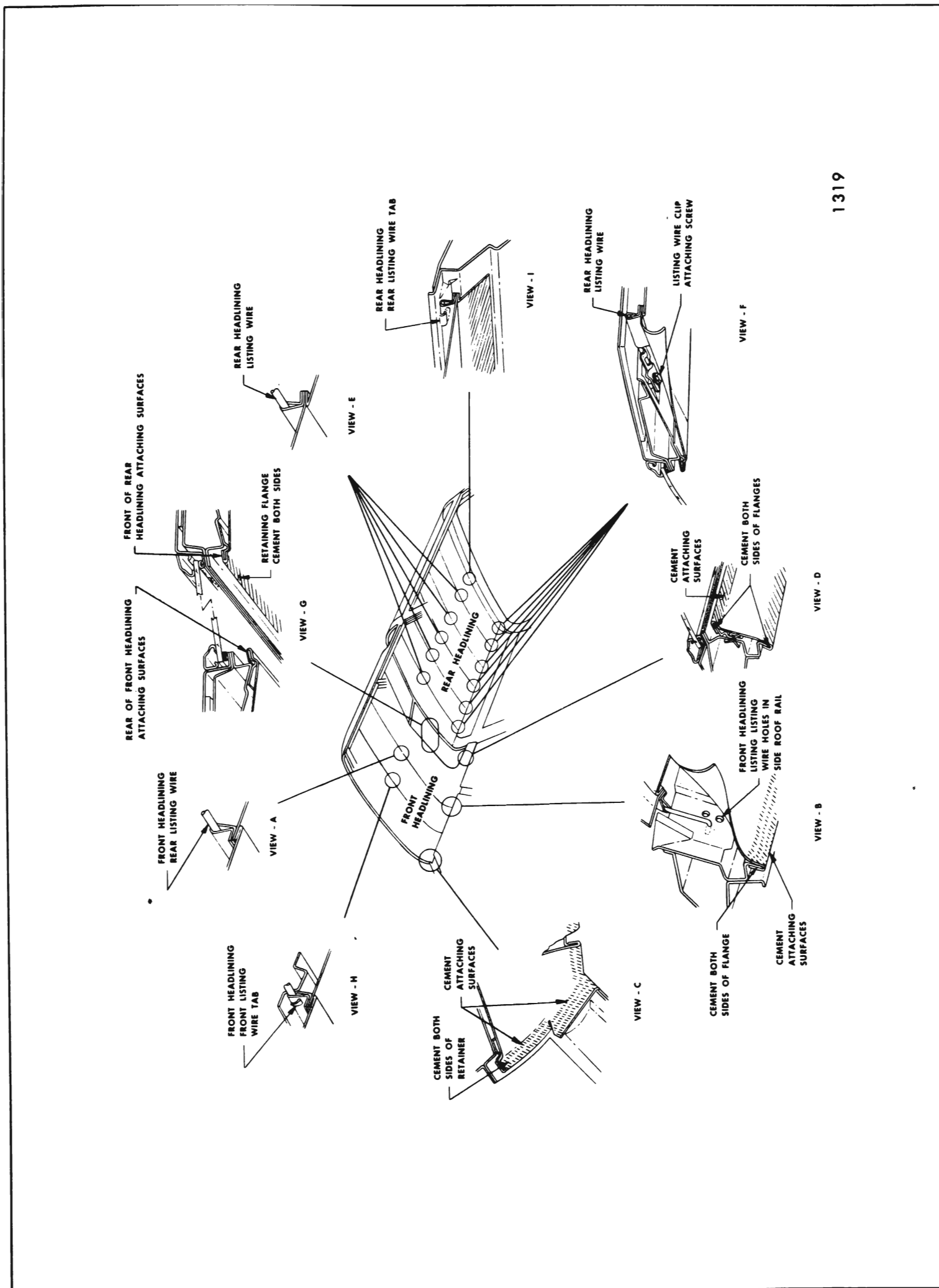

1319

Fig. 4-7—Headlining Installation "55" and "65" Styles

**Installation**

1. If previously removed, install listing wires into pockets of headlining.

**IMPORTANT:** Listing wires removed from old headlining must be installed in corresponding pockets of replacement headlining.

2. Apply approved trim cement to headlining attaching surfaces.
3. Apply approved trim cement to metal retainers and flanges.
4. Lift headlining into body, install listing wires into holes in side roof rail, center headlining to roof, hook front listing wire over tab on roof bow and bend down tab (View "H", Fig. 4-7).

**NOTE:** Listing wires should rest tight against roof panel. Working from front to rear, attach headlining to retainers and flanges while stretching and removing wrinkles. Reinstall all previously removed parts.

**REAR HEADLINING ASSEMBLY****Removal**

1. Place protective covering over seats and floor.
2. Prior to removing headlining, remove the following items:
  - a. Sunshade supports.
  - b. Front skylight center division garnish molding.
  - c. Side skylight front upper garnish molding.
  - d. Rear roof headlining trim finish molding.
  - e. All finishing lace around perimeter of headlining.

3. Carefully detach headlining at cemented edges.
4. Starting at front remove listing wires from roof inner rails (View "F", Fig. 4-7).
5. At rear listing wire bend down tab securing wire to bow (View "I", Fig. 4-7).
6. Gather or roll headlining with listing wires on outside to keep headlining clean and remove headlining assembly from car.

**Installation**

1. If previously removed, install listing wires into pockets of new headlining assembly.

**IMPORTANT:** Listing wires removed from old headlining must be installed in corresponding pockets of new headlining.

2. Apply approved trim cement to attaching surfaces of headlining material.
3. Apply approved trim cement to retaining flanges of roof panel.
4. Lift headlining into body, install center of rear listing wire over hook at rear bow and bend over tab (View "I", Fig. 4-7).
5. Working forward install remainder of listing wires into clips and secure clips to roof (View "F", Fig. 4-7).
6. Listing wires must rest tight against the roof. If necessary adjust listing wires by moving clips at attaching screws.
7. Attach entire perimeter of headlining to retaining flanges, removing wrinkles by stretching the material as required.
8. Replace previously removed parts.