

SECTION A

DRUM BRAKE, PARKING BRAKE, WHEEL CYLINDER AND MASTER CYLINDER

ALL SERIES

CONTENTS

Division	Subject	Page No.
I	TROUBLE DIAGNOSIS:	
	Inspecting and Testing Brakes	50-3
	Brake Trouble Diagnosis Chart	50-4
II	DESCRIPTION AND OPERATION:	
	Description of Brake Mechanism	50-5
	Operation of Brake Mechanism	50-8
III	ADJUSTMENTS AND MINOR SERVICE:	
	Service Brake Adjustment	50-8
	Parking Brake Adjustment	50-9
	Replace or Reline Brake Shoes	50-9
	Repair Brake Lining	50-11
	Inspecting and Reconditioning Brake Drums	50-12
	Filling, Bleeding and Flushing Brake System	50-13
	Wheel Bolt Removal and Installation	50-15
IV	REMOVAL AND INSTALLATION: (Not Applicable)	
V	OVERHAUL AND MAJOR SERVICE:	
	Wheel Cylinder Overhaul	50-16
	Parking Brake Cable Replacement	50-16
	Master Cylinder Overhaul	50-17
	Replacing Brake Pipes	50-20
VI	SPECIFICATIONS:	
	Brake Specifications	50-21

DIVISION I

TROUBLE DIAGNOSIS

50-1 INSPECTION AND TESTING BRAKES

A. Inspecting Brakes

At reasonable frequent intervals, the brakes should be inspected for pedal travel, which is the distance the pedal moves toward the floor from a fully-released position. Inspection should be made with the brake pedal firmly depressed (approximately 100 lbs. pedal load) while the brakes are cold. Heat generated by high-speed stops will expand the brake drums and increase shoe-to-drum clearance, thereby permitting the pedal to move closer to the floor than with cold brakes. Pedal travel can be measured with a steel tape located on the top of the pedal pad and indicating off of the lower portion of the steering wheel rim. Pedal travel should not be less than the following:

4D-4F-4G-4H	Manual Drum	4 3/4"
4D-4F-4G-4H	Power Drum	2 3/8"
All	Power Disc	1 3/4"

On power brake-equipped cars, pump the pedal a minimum of three (3) times with the engine off before making pedal travel checks. This exhausts all vacuum from the power booster.

Brake shoe linings should not be permitted to wear down until rivets contact drums because drums will be scored. As car mileage approaches the point where relining may be required, it is advisable to remove one or more drums for inspection of lining in order to avoid possibility of damaging brake drums.

B. Testing Brakes

Overall brake performance cannot be properly tested with the wheels jacked up because this procedure does not test the self-energizing servo action of the brake shoes and the effect of car weight distribution on deceleration.

Brakes should be tested on dry, clean, reasonably smooth and level roadway. A true test of brake performance cannot be made if roadway is wet, greasy or covered with loose dirt so that all tires do not grip the road equally. Testing will also be adversely affected if roadway is crowned so as to throw weight of car toward wheels on one side or if roadway is so rough that wheels tend to bounce.

Test brakes at different car speeds with both light and heavy pedal pressure; however, avoid locking the wheels and sliding the tires on roadway. Locked wheels and sliding tires do not indicate brake efficiency since heavily braked, but turning wheels will stop car in less distance than locked wheels. More tire-to-road friction is present with a heavily braked turning tire than with a sliding tire.

C. External Conditions that Affect Brake Performance

In addition to roadway conditions mentioned above (subparagraph b), the following external conditions may affect brake performance and should be corrected before work is done on the brake mechanism.

1. Tires. Tires having unequal contact and grip on road will cause unequal braking. Tires must be equally inflated and tread pattern of right and left tires must be approximately equal.
2. Car Loading. When car has unequal loading, the most heavily loaded wheels require more braking power than others. A heavily loaded car requires more braking effort.
3. Front Wheel Bearings. A loose front wheel bearing permits the drum to tilt and have spotty contact with brake shoe linings causing erratic brake action. See Group 100.
4. Front End Alignment. Misalignment of the front end particularly in regard to limits on camber and theoretical king pin inclination will cause brake action to appear unequal between sides.
5. Shock Absorbers. Faulty shock absorbers that permit bouncing of car on quick stops may give the erroneous impression that brake action is too severe.

50-4 1972 BUICK SERVICE MANUAL

50-2 BRAKE TROUBLE DIAGNOSIS CHART

CAUSE	SYMPTOM	Excessive Brake Pedal Travel	Brake Pedal Gradually Increases	Excessive Brake Pedal Effort	Brakes Slow to Respond	Brakes Slow to Release	Brakes Drag (Side to Side)	Uneven Braking Action (Front to Rear)	Uneven Braking Action (Side to Side)	Scraping Braking Action	Brakes Squeak During Application	Brakes Squeak During Brakes	Brakes Chatter During Stop	Brakes Groan at End of Stop	Brake Tell-Tale Glows During Stop
Leaking Brake Line or Connection		X	XX								X				XX
Leaking Wheel Cylinder or Piston Seal		X	XX			X				X					X
Leaking Master Cylinder		X	XX												X
Air In Brake System		XX									X				XX
Contaminated or Improper Brake Fluid						X	X	X							X
Leaking Vacuum System					XX	X									
Restricted Air Passage in Power Head					X	XX	X								
Damaged Power Head					X	X	X	X	X						
Improperly Assembled Power Head Valving					X	X	X	X	XX						
Worn Out Brake Lining - Replace					X	X				X	X	X	X	X	X
Uneven Brake Lining Wear - Replace and Correct		X				X				X	X	X	X	XX	X X
Glazed Brake Lining - Sand Lightly					XX		X			X	X		X	X	
Incorrect Lining Material - Replace					X	X				X	X			X	X
Contaminated Brake Lining - Replace						XX				XX	XX	X	X	X	X
Linings Damaged by Abusive Use - Replace					X	XX				X	X	X	X	X	X
Excessive Brake Lining Dust - Remove with Air					X	XX				XX	XX		X	XX	X
Heat Spotted or Scored Brake Drums or Rotors						X				X	X		X	X	XX X
Out-of-Round or Vibrating Brake Drums														X	XX
Out-of-Parallel Brake Rotors															XX
Excessive Rotor Run-Out															X
Faulty Automatic Adjusters		X								X	X	X			X
Incorrect Wheel Cylinder Sizes					X	X				X	X				
Weak or Incorrect Brake Shoe Retention Springs						X		X	XX	X	X	XX	X	XX	
Brake Assembly Attachments Missing or Loose		X								X	X	X	X		X X X
Insufficient Brake Shoe Guide Lubricant								X	X	X	X	XX	XX		
Restricted Brake Fluid Passage or Sticking Wheel Cylinder Piston				X	X	X	X	X	X	X	X				
Faulty Metering Valve (Disc Only)		X			X	X	X	X	X	X	X				X
Brake Pedal Linkage Interference or Binding					X		X	XX	XX						
Improperly Adjusted Parking Brake										X					
Drums Tapered or Threaded													XX		
Incorrect Front End Alignment											XX				
Incorrect Tire Pressure											X	X			
Incorrect Wheel Bearing Adjustment		X											X		X
Loose Front Suspension Attachments											X		XX		X X
Out-of-Balance Wheel Assemblies															XX
Operator Riding Brake Pedal		X	X	X						X	X				X
Improperly Adjusted Master Cylinder Push Rod		X						X	XX						X
Sticking Wheel Cylinder or Caliper Pistons					X		X	X	X	X	X				
Faulty Proportioning Valve					X		X	X	X						

XX - Indicates more probable cause(s)

X - Indicates causes

Figure 50-1 Brake Trouble Diagnosis Chart

DIVISION II

DESCRIPTION AND OPERATION

50-3 DESCRIPTION OF BRAKE MECHANISM

The brake mechanism includes a brake drum and a brake assembly at each wheel and two separate and independent control systems for applying the brakes: (1) Parking brake control system which operates the rear wheel brakes only. (2) Service brake control system which operates both front and rear wheels and has a self-adjusting mechanism.

A. Wheel Brake Assemblies

Enclosing each wheel brake assembly is a finned brake drum having a cast iron braking surfacing. The fins give greater external heat dissipation, and the cast iron provides an ideal braking surface for long lining life.

Front brake drums on the lighter Specials and Skylarks, and rear brake drums on all models have cast iron rims fused to pressed steel discs.

The brake assembly at each wheel uses a primary (front) and secondary (rear) brake shoe of welded steel construction. One-piece molded linings are bonded or riveted to brake shoes. The primary shoe lining is shorter than the secondary shoe lining and is of different composition; therefore, the two shoes are not interchangeable. See Figure 50-2.

movement of the shoe. The notched upper end of each shoe is held against the single anchor pin by a heavy coil spring. An adjusting screw and spring connects the lower ends of both shoes together and provides adjustment for clearance with the brake drum. There is no anchor pin adjustment as the pins are fixed in the backing plates.

A hydraulic wheel cylinder, mounted on the backing plate between the upper ends of the brake shoes, forces the shoes against the brake drum when the service brakes are applied. On rear wheels only, a lever mounted on each secondary shoe and connected to the primary shoe by a strut is used for applying the shoes when used as parking brakes. See Figure 50-3.

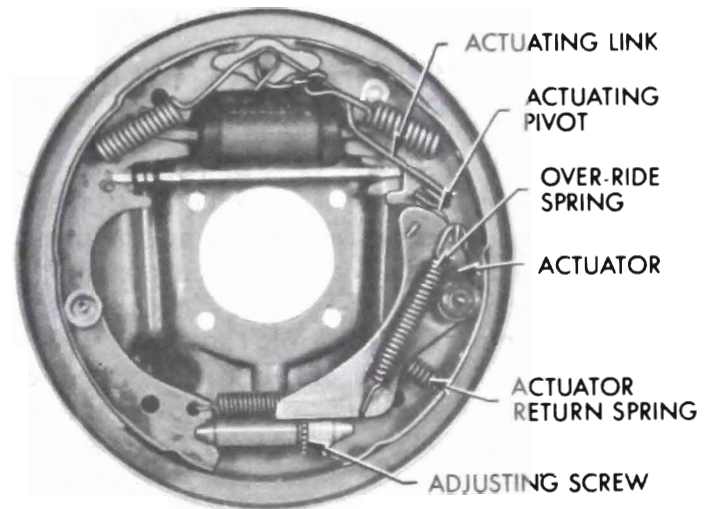

50-12

Figure 50-3 - Left Rear Wheel Brake Assembly

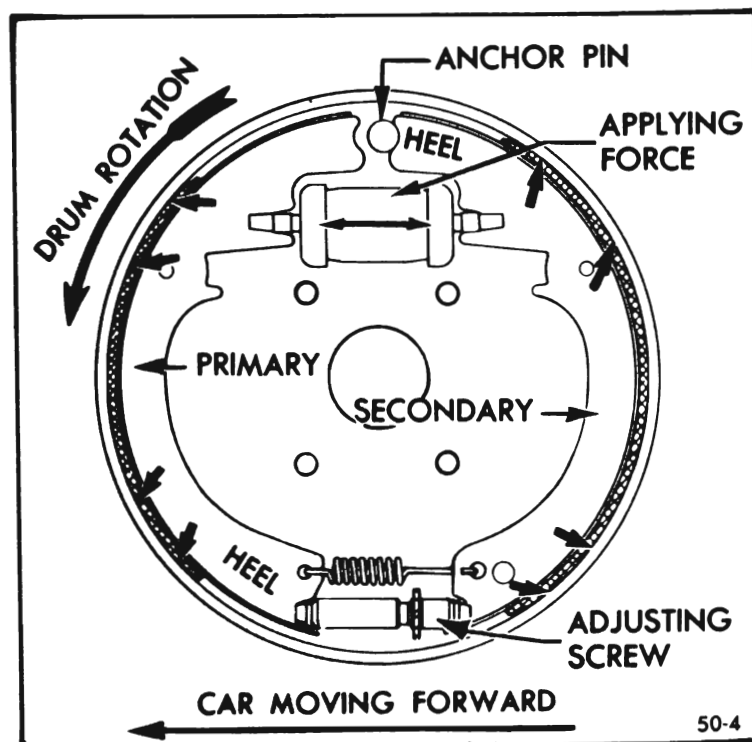

Figure 50-2 - Brake Shoe Action

When the brake shoes contact the rotating drum, in either direction of car travel, they move with the drum until one shoe is stopped by the anchor pin and the other shoe is stopped through the connecting adjusting screw. Frictional force between drum and shoe lining tries to rotate each shoe outward around its anchor point, but the drum itself prevents this rotation; consequently, the shoes are forced more strongly against the drum than the applying force is pushing them. See Figure 50-2. It is also evident that the force applied by the drum to one shoe is imparted to the other shoe through the connecting adjusting screw.

Utilization of the frictional force to increase the pressure of shoes against the drum is called self energizing action. Utilization of force in one shoe to apply the opposite shoe is called servo action. The self-energizing servo action of Buick brakes provides powerful braking action with relatively light pedal pressure.

B. Parking Brake Control System

The parking brake control system, which applies only the rear wheel brakes, uses a foot-operated lever, cables

Each brake shoe is held against the backing plate by a hold-down spring, pin and cup which allows free

and brake shoe levers and struts. By means of an equalizer, the front parking brake cable is connected to the forward portion of a center cable. See Figures 50-17 and 18.

This center cable is routed rearward from the equalizer through retaining guides which attach to the underbody. The center cable attaches at either end to a rear cable assembly. Each rear cable connects to the free lower end of a brake shoe lever. These levers (one in each rear brake shoe assembly) pivot on the secondary shoes. Struts are mounted between the brake shoe levers and the primary shoes. When the parking brake pedal is depressed, all cables are put in tension and the rear brake shoes are expanded against the drums. See Figure 50-3.

C. Service Brake Control System

See Section D for Delco Moraine Power Brakes.

The regular foot-powered service brake control system is a pedal operated hydraulic system which applies the brakes at all four wheels with equalized pressure. The hydraulic system consists of one master cylinder connected by pipes and flexible hoses to a wheel cylinder mounted between the brake shoes at each wheel. The master cylinder, pipes, hoses and four wheel cylinders are filled with brake fluid. A 3/16" O.D. brake pipe connects the front portion of the master cylinder assembly to the front portion of a brake warning light switch and distributor assembly located on the left frame rail. This switch provides a warning to the driver if one part of the hydraulic system fails (pressure to front and rear wheels is not equal). See Group 120 for checking procedures for brake warning light switch. From the front portion of the distributor, two separate 3/16" O.D. brake pipes are routed to the front wheel brakes.

Brake warning light switches are used only on cars with drum brakes. All disc brake cars have combination valves. (See Section B for combination valves.)

A 1/4" O.D. brake pipe connects the rear portion of the master cylinder assembly to the rear portion of the switch and distributor assembly. From the rear portion of the distributor, a 1/4" O.D. brake pipe extends to the rear frame area where a flexible hose connects to two 3/16" O.D. brake pipes attached to the rear axle assembly to operate the rear wheel brakes. See Figures 50-19, 20, or 21.

The brake pedal is suspended from a pivot shaft on the pedal support. The master cylinder push rod attaches to the shank of the pedal. The overall mechanical advantage in the brake linkage is approximately six to one for manual brakes.

The pivot shaft in the brake pedal has nylon bearings which are lubricated during installation but do not require periodic lubrication. Whenever the linkage is disassembled, however, all friction surfaces should be lightly coated with Lubriplate. The pedal is stopped in the released position by contact of the push rod with the stop plate in the master cylinder.

A plunger type stop light switch, which operates mechanically, is mounted on a bracket just rearward of the brake pedal. When the brakes are fully released, the brake pedal bears against the plunger and depresses it in the "off" position. As the pedal arm moves forward during brake application, the spring-loaded plunger moves to the "on" position. See Figures 50-22 or 23.

The master cylinder contains two fluid reservoirs and two cylindrical pressure chambers in which force applied to the brake pedal is transmitted to the fluid which actuates the brake shoes. Breather ports and compensating ports permit passage of fluid between each pressure chamber and its fluid reservoir during certain operating conditions. A vented cover and flexible rubber diaphragm at the top of the master cylinder reservoirs seal the hydraulic system from possible entrance of contamination, while at the same time permitting expansion or contraction of fluid within the reservoirs without direct venting. In the pressure chambers, coil springs hold rubber primary cups against the end of the pistons. These cups and rubber secondary seals on the opposite end of the pistons prevent escape of fluid past the pistons. The piston is retained in the cylinder by a stop plate. A rubber boot is installed over this end of the cylinder to exclude foreign matter. See Figure 50-4.

Each wheel cylinder contains two pistons and two rubber cups which are held in contact with the pistons by a central coil spring with cup expanders to provide a fluid-tight seal. The wheel cylinder cups are of a special heat resisting rubber. Cups of this material must have an expander to hold the lips of the cup out against the wheel cylinder bore. These cup expanders are crimped on each end of the wheel cylinder spring. The inlet port for brake fluid is located between the pistons so that when fluid pressure is applied, both pistons move outward toward the ends of wheel cylinders. The pistons impart movement to the brake shoes by means of connecting links which seat in the pistons and bear against webs of the shoes. Rubber boots enclose both ends of the cylinder to exclude foreign matter. A valve for bleeding the brake pipes and wheel cylinder is located above the inlet port. See Figure 50-5.

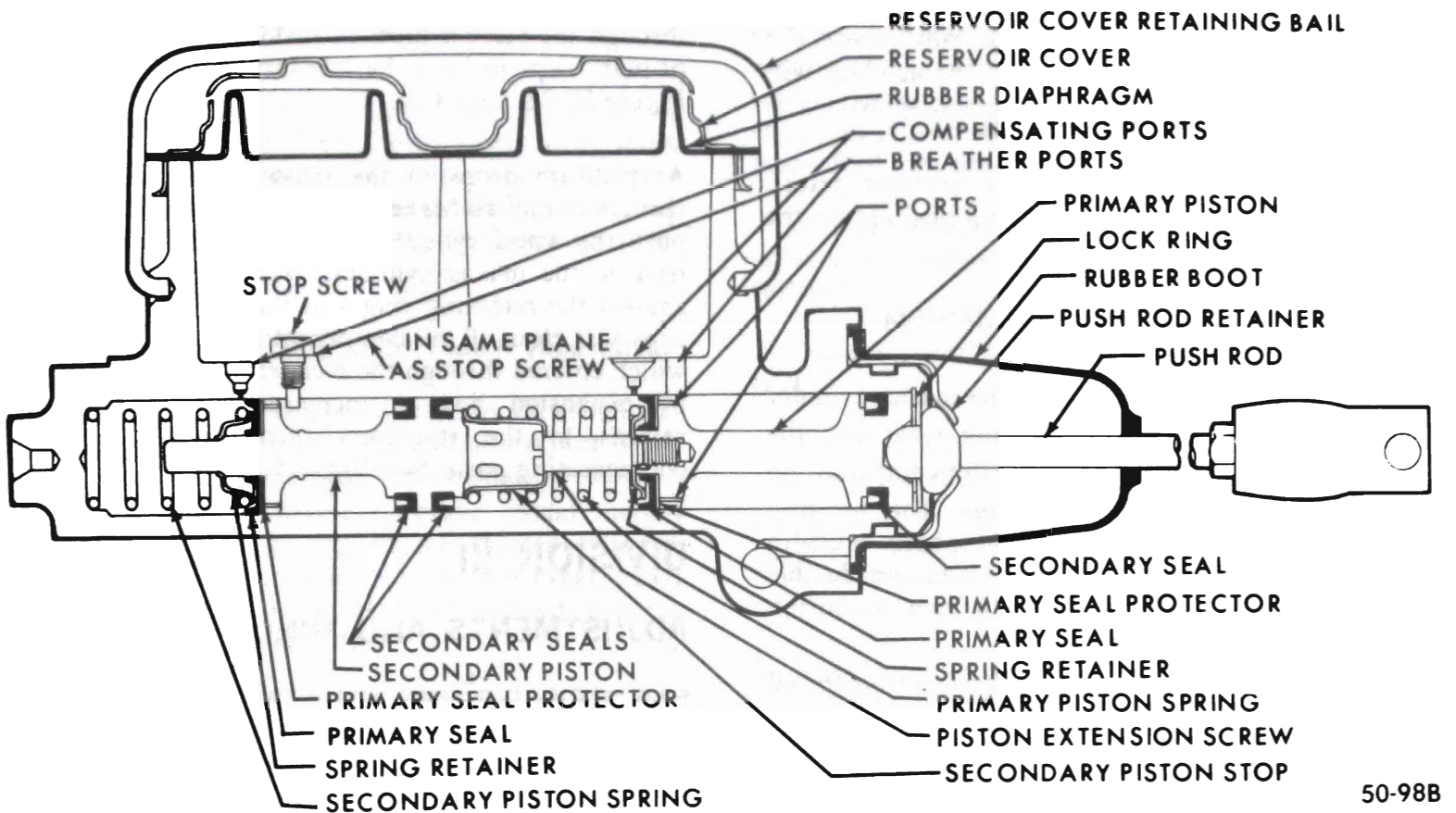

50-98B

Figure 50-4 Typical Master Cylinder

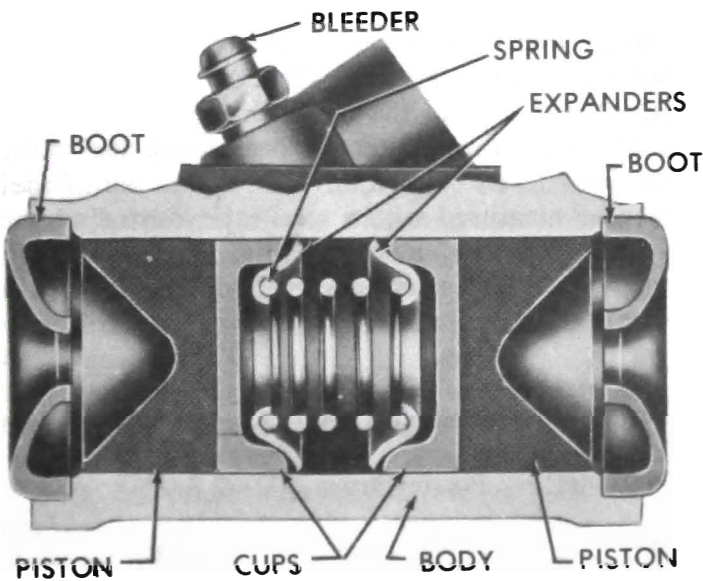

50-8

Figure 50-5 Typical Wheel Cylinder

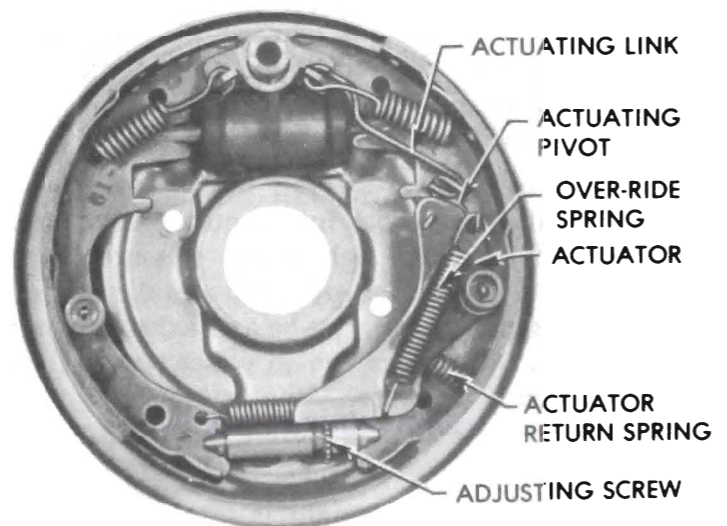

50-9

Figure 50-6 Self-Adjuster Assembly

D. Self-Adjusting Brake

The self-adjusting brake mechanism consists of an actuator, actuator pivot, actuator return spring, override spring and an actuating link. The self adjusting brake mechanism is mounted on the secondary shoe and operates only when the brakes are applied while the car is moving in a rearward direction and only when the secondary shoe moves a predetermined distance toward the brake drum. See Figure 50-6.

When the car is moved in a rearward direction and the brakes are applied, friction between the primary shoe and the drum forces the primary shoe against the anchor pin. Hydraulic pressure in the wheel cylinder forces the upper end of the secondary shoe away from the anchor pin. The upper end of the actuator is prevented from moving by the actuating link. This causes the actuator to pivot on the secondary shoe forcing the actuator lever against the adjusting screw star wheel. If the brake linings are worn enough to allow the secondary shoe to move the predetermined

distance, the actuator will turn the adjusting screw one tooth. If the secondary shoe does not move the predetermined distance, movement of the actuator will not be great enough to rotate the adjusting screw.

When the brakes are released, the actuator return spring returns the actuator to adjusting position on the adjusting screw.

50-4 OPERATION OF BRAKE MECHANISM

When the brakes are fully released, the master cylinder pistons are held against the retaining ring; and the primary cups are held just clear of the compensating ports by the master cylinder springs. The pressure chambers are filled with fluid at atmospheric pressure due to the open compensating ports and the flexible reservoir diaphragm. See Figure 50-26, view A.

When the brake pedal is depressed, force is transferred through the push rod to the master cylinder primary piston which moves forward. Under normal conditions, the combination of hydraulic pressure and the force of the primary piston spring move the secondary piston forward at the same time. When the pistons have moved forward so that their primary cups cover the bypass holes, hydraulic pressure is built up and transmitted to the front and rear wheels. Hydraulic pressure behind the wheel cylinder cups forces the pistons outward, causing the brakes to be applied. See Figure 50-26, View B.

Movement of all brake shoes into contact with drums is accomplished with very light pedal pressure. Since pressure is equal in all parts of the hydraulic system, effective braking pressure cannot be applied to any one drum until all of the shoes are in contact with their respective drums; therefore, the system is self-equalizing.

On rapid stops, some car weight is transferred from the rear to the front wheels; consequently, greater braking power is required at the front wheels in order to equalize the braking effect at front and rear wheels. Greater force is applied to the front brake shoes by using larger wheel cylinders.

When the brake pedal is released, the master cylinder springs force the pedal back until the push rod contacts the retaining ring in the master cylinder. This spring also forces the pistons and primary cups to follow the push rod.

At the start of a fast release, the pistons move faster than the fluid can follow in returning from the pipes and wheel cylinders; therefore, a partial vacuum is momentarily created in the pressure chamber. Fluid

supplied through the breather ports is then drawn through the bleeder holes in piston heads and past the primary cups to keep the pressure chamber filled. See Figure 50-26, view C.

As pressure drops in the master cylinder, the shoe springs retract all brake shoes and the connecting links push the wheel cylinder pistons inward, forcing fluid back to the master cylinder. With the piston bearing against the retaining ring and the lips of the primary cups just clear of the compensating ports, excess fluid which entered through the bleeder holes or was created by expansion due to increased temperature, now returns to the reservoirs through the uncovered compensating ports. See Figure 50-26, view D.

DIVISION III

ADJUSTMENTS AND MINOR SERVICE

50-5 SERVICE BRAKE ADJUSTMENT

A. Preliminary Checks

1. At reasonable frequent intervals, the brakes should be inspected for pedal travel, which is the distance the pedal moves toward the floor from a fully-released position. Inspection should be made with the brake pedal firmly depressed (approximately 100 lbs. pedal load) while the brakes are cold. Heat generated by high speed stops will expand the brake drums and increase shoe-to-drum clearance, thereby permitting the pedal to move closer to the floor than with cold brakes. Pedal travel can be measured with a steel tape located on the top of the pedal pad and indicating off of the lower portion of the steering wheel rim. Pedal travel should not be more than the following:

4D-4F-4G-4H	Manual Drum	4 3/4"
4D-4F-4G-4H	Power Drum	2 3/8"
All	Power Disc	1 3/4"

On power brake-equipped cars, pump the pedal a minimum of three (3) times with the engine off before making pedal travel checks. This exhausts all vacuum from the power booster.

2. Remove one front wheel with hub and drum assembly (4D-4F-4G-4H only less Sportwagon). Inspect brake lining. If lining is worn nearly to rivets, reline brakes (Paragraph 50-7).

3. Check fluid level in master cylinder reservoir and add fluid if necessary (Paragraph 50-10).

4. Fully release parking brake and place transmission in neutral.

5. Pull on both ends of rear brake cable a number of times to make sure that cables operate rear brake shoes freely and do not bind in conduits. Check for free movement of cable in brake cable sheathing and check brake cable spring for tension. Replace cable assembly if spring is weak or broken.

B. Pedal Height and Stop Light Switch Adjustment

Brake pedal height cannot be adjusted in either manual or power brake cars. In both manual and power brake cylinders, non-adjustable push rods connect directly to the brake pedals. Therefore, brake pedal height depends entirely on a stop in the master cylinder, which is also non-adjustable. No external brake pedal return spring is used, so pedal return depends entirely on a spring within the cylinder.

Make certain that the brake pedal returns completely when released slowly. If the pedal does not return freely, check all pivot points for binding or lack of lubrication. With pedal in fully released position, the stop light switch plunger should be fully depressed against the pedal shank. Adjust switch by moving in or out as necessary. See Figures 50-22, 23, or 24.

C. Adjustment at Wheels

1. Using a suitable punch, knock out lanced area in brake backing plate. If this is done with the drum installed on the car, the drum must be removed and all metal cleaned out of the brake compartment. Be sure to procure a new hole cover and install it in the backing plate after adjustment to prevent dirt and water from getting into the brakes. Use J-6166 to turn brake adjusting screw; expand brake shoes at each wheel until the wheel can just be turned by hand. The drag should be equal at all wheels.

2. Back off brake adjusting screw at each wheel 30 notches. If shoes still drag lightly on drum, back off adjusting screw one or two additional notches. Brakes should be free of drag when screw has been backed off approximately 12 notches. Heavy drag at this point indicates tight parking brake cables.

3. Install adjusting hole cover in brake backing plate when adjustment is completed.

4. Check parking brake adjustment as described in Paragraph 50-6.

50-6 PARKING BRAKE ADJUSTMENT

Adjustment of parking brake cable is necessary whenever the rear brake cables have been disconnected or when cables have been stretched through extended

use. Need for parking brake adjustment is indicated if the service brake operates with good reserve, but the parking brake pedal can be depressed more than 8 ratchet clicks on 4D-4F-4G-4H Series cars and 16 clicks on 4L-4N-4R-4P-4U-4V-4Y Series cars under heavy foot pressure.

After making certain that service brakes are in good adjustment, adjust parking brake mechanism as follows:

1. Depress parking brake pedal exactly three ratchet clicks.

2. Loosen jam nut located at rear of equalizer adjusting nut. See Figures 50-17 or 18. Then tighten adjusting nut until rear wheels can just be turned rearward using two hands but are locked when forward rotation is attempted. Tighten jam nut against adjusting nut.

3. With mechanism totally disengaged, rear wheels should turn freely in either direction with no brake drag.

It is very important that parking brake cables are not adjusted too tightly to cause brake drag. With automatic brake adjusters, a tight cable causes brake drag and also positions the secondary brake shoe, hence the adjuster lever, so that it continues to adjust to compensate for wear caused by the drag. The result is a cycle of wear and adjustment that can wear out linings very rapidly.

50-7 REPLACE OR RELINE BRAKE SHOES

The most satisfactory method of replacing brake lining is to install new shoe and lining assemblies. This insures brake shoes that are not distorted through use and linings that are properly riveted to shoes and ground to correct radius by accurate factory machinery.

Each brake shoe and lining set listed in the Buick Master Parts Catalog under Group 5.017 is packed in a carton containing two primary and two secondary shoe and lining assemblies, enough for two wheels. Sets are available in standard size and .030" oversize for use where brake drums have been rebored.

Each lining set is packed in a carton containing two primary and two secondary linings, enough for two wheels, and packaged with enough rivets for installation on the shoes.

Brake shoe lining sets are listed in the Buick Master Parts Catalog under Group 5.018 if the old shoes are to be relined. Linings are shaped, drilled, and ground to correct thickness and radius. Lining sets are available in standard and .030" oversize.

Brake linings are made of asbestos for its heat resisting qualities and compounds of bonding material for strength. Some bonding materials are used for their lubricating qualities to guard against drum scoring while others are used to control the friction producing property of the lining, called "coefficient of friction". Good molded linings also have imbedded particles of material used to control friction and wear. When linings are ground, some of the surface particles may be pulled out, leaving a pitted appearance. These pits do not affect lining efficiency.

The heat generated by friction will produce different effects in different compounds of bonding material. Some compounds increase friction with increased temperature, which might cause grabbing or locking. Other compounds lose friction with increased temperature, which might cause substantially lowered braking power.

Brake lining compounds must be carefully selected to produce the braking friction required at the temperatures normally attained in each vehicle application.

A. Removal and Inspection

When paragraph references in parentheses have an asterisk, the operation referred to is additional work not covered by the standard replacement operation.

1. Jack up car and remove wheel and brake drum (rear), or hub and drum assembly (front).

Stops located on the backing plates will prevent pistons from leaving the wheel cylinders; however, brake pedal must not be operated while a brake drum is removed since damage to wheel cylinder rubber boots will result.

It may be necessary to back off the brake shoe adjustment before the brake drums can be removed. To back off shoe adjustment, rotate shoe adjusting screw upward.

2. Unhook the primary and secondary shoe return springs using large pliers.

3. Remove shoe hold down springs.

4. Lift up on actuator, unhook actuating link from anchor pin, then remove.

5. Spread shoes to clear wheel cylinder connecting links, remove parking brake strut and spring (rear only), disconnect cable from parking brake lever, remove shoes from the backing plate.

6. Separate the brake shoes by removing adjusting-screw and lock spring. Remove parking brake lever from secondary brake shoe (rear only). See Figure 50-3.

7. Clean all dirt out of brake drum, using care to avoid getting dirt into front wheel bearings. Inspect drums and replace or recondition if required (*Paragraph 50-9*).

8. Blow all dirt from brake assemblies and inspect for any unusual condition.

9. Wheel cylinders having torn, cut, or heat-cracked boots should be completely overhauled.

Inspection for leakage may be accomplished at the boot center hole after removal of link pin. Fluid coatings on piston within cylinder and on end of link pin removed from boot are normal, as cylinder contains a porous DUREX PISTON WHICH IS IMPREGNATED WITH A CORROSION INHIBITING FLUID. Fluid spilling from boot center hole, after link pin is removed, indicates cup leakage and necessity for completely over-hauling cylinder (*Paragraph 50-11*).

10. If working at rear wheels, inspect backing plate for oil leak past wheel bearing oil seals. Correct any leak by installation of new seals (Group 40).

11. Check all backing plate attaching bolts to make sure they are tight. Using fine emery cloth, clean all rust and dirt from shoe contact surfaces on plate.

B. Relining Brake Shoes

If old brake shoes are to be relined, inspect shoes for distortion and for looseness between the rim and web; these are caused for discarding any shoe. If shoes are serviceable, be governed by the following points in installing new linings:

1. Remove old linings by drilling out rivets. Punching rivets out will distort shoe rim. Thoroughly clean surface of shoe rim and file off any burrs or high spots.

2. Use Buick brake lining or equivalent and the rivets included in lining package which are of the correct size. The rivets must fit the holes with the solid body of rivet extending through the shoe rim, but no farther.

Keep hands clean while handling brake lining. Do not permit oil or grease to come in contact with lining.

3. Start riveting at center of shoe and lining and work toward the ends. Use a roll set for riveting; a star set might split the tubular end and then the rivet would not fill the hole. The primary lining is shorter than secondary lining; therefore, the rivet holes at each end of the shoe rim are not used.

4. After riveting is completed, lining must seat snugly against shoe with no more than .005" separation midway between rivets. Check with a .004" (Go) and a .006" (No Go) feeler gage.

C. Installation and Adjustment

1. On rear brakes only, lubricate fulcrum end of parking brake lever with Delco Brake Lubricant or equivalent, then attach lever to secondary shoe. Make sure that lever is free moving.

2. Connect brake shoes together with adjusting screw spring, then place adjusting screw in position. When installing the adjusting screw spring and adjusting screw, make sure the spring does not touch the starwheel portion of the adjusting screw; and, also, when installing adjusting screw, make sure right hand thread adjusting screw is on left side of car and left hand thread adjusting screw is on right side of car. Make certain starwheel lines up with adjusting hole in backing plate.

3. Lubricate shoe contact surfaces on backing plate with a thin coating of Delco Brake Lubricant or equivalent. On rear brakes, sparingly apply same lubricant where brake cable contacts backing plate.

4. Place brake shoes on backing plate, at the same time engaging shoes with wheel cylinder links. The primary shoe (short lining) goes toward front of car. On rear brakes, connect cable to parking brake lever and install strut and spring between lever and primary shoe.

5. Install actuator, actuator return spring and actuating link. If old brake shoe return springs are nicked, distorted or of doubtful strength (discolored from heat), it is advisable to install new parts.

6. Install shoe hold down springs.

7. Install the primary and secondary shoe return springs using large pliers. Be careful not to distort springs.

8. Measure brake drum I.D. using inside caliper portion of Tool J-21177. Adjust brake shoes to dimension obtained on outside caliper portion of Tool J-21177.

9. Lubricate and adjust front wheel bearings. Install brake drums and wheels.

10. If any hydraulic connections were disturbed, bleed hydraulic system (Paragraph 50-10).

11. Adjust parking brake as described in Paragraph 50-6.

12. Inspect all brake pipes, hoses and connections for evidence of fluid leakage. Tighten any leaking connection. Then apply heavy pedal pressure to brake pedal and recheck connections.

13. Check fluid level in master cylinder and add fluid if necessary.

14. Check brake pedal for proper feel and for proper return.

15. Remove jacks and road test car for proper brake action (Paragraph 50-1). Brakes must not be severely applied immediately after installation of new brake shoes or linings. Severe application may permanently damage new linings and may score brake drums. When linings are new, they must be given moderate use for several hundred miles of burnishing.

50-8 REPAIR BRAKE LINING

This procedure is to be used when brake action is unequal, severe, hard, noisy or otherwise unsatisfactory and when brake linings have had little wear.

1. Check fluid in master cylinder and add fluid if necessary.

2. Check brake pedal for proper feel and for proper return.

3. Jack up car in a safe manner and remove all wheels.

4. Remove all brake drums. Brake pedal must not be operated while drums are removed.

5. Clean all dirt out of brake drums, using care to avoid getting dirt into front wheel bearings. Inspect drums and replace or recondition if required (Paragraph 51-3).

6. Blow all dirt from brake assemblies, then inspect brake linings for uneven wear, oil soaking, loose rivets or imbedded foreign particles. If linings are oil soaked, replacement is required.

7. If linings are otherwise serviceable, tighten or replace loose rivets and thoroughly clean all steel or other imbedded particles from surfaces and rivet counterbores of linings.

8. If brake linings at any wheel show a spotty wear pattern indicating uneven contact with brake drum, it is advisable to true up the linings with a light grinding cut, if suitable grinding equipment is available. If brake action is unequal, severe or hard, indicating that brake shoes are not centralized in drums, the grinder may also be used to correct this condition. Grinding equipment which locates and swings off the wheel spindle or axle shaft may be used to grind shoes concentric with drums, or a bench mounted grinder may be used to grind shoes to the proper radius (.010" less than drum radius). The instructions of equipment manufacturer must be carefully followed.

9. Check all backing plate bolts to make sure they are tight.

10. Measure brake drum I.D. using inside caliper portion of Tool J-21177. Adjust brake shoes to dimension obtained, on outside caliper portion of Tool J-21177. See Figures 50-7 and 8.

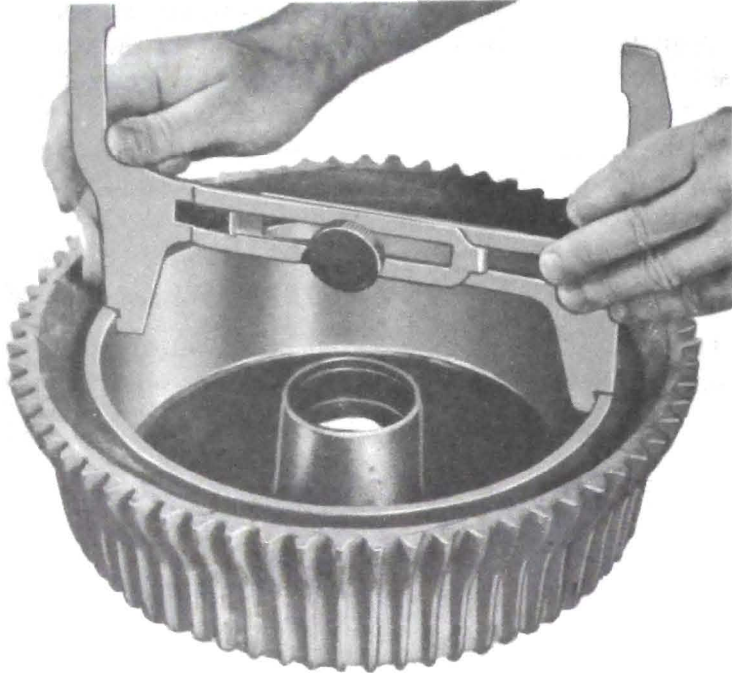

50-100

Figure 50-7-Measuring Brake Drum I.D..

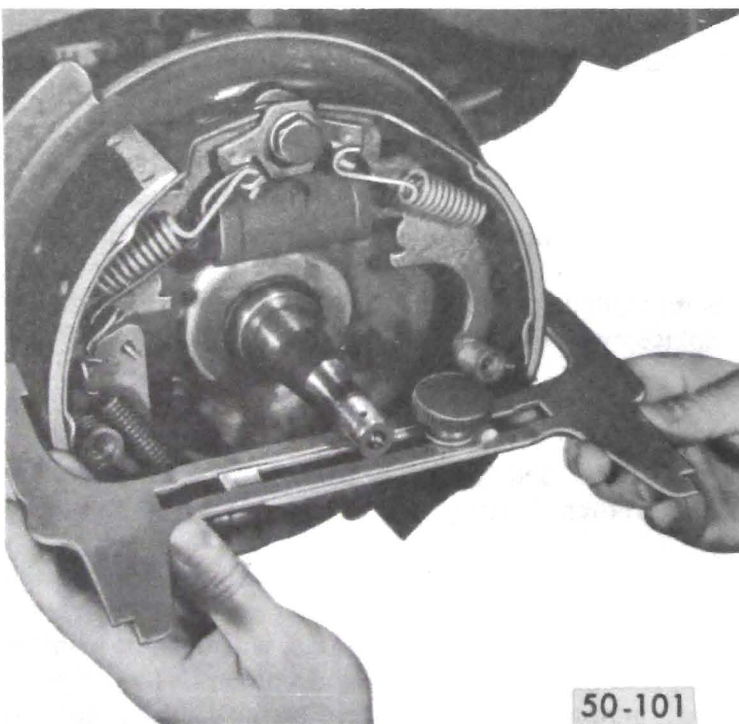

50-101

Figure 50-8-Adjust Brake Shoes

11. Lubricate front wheel bearings, if necessary. Install front hub and drum assemblies and adjust wheel bearings. Install wheel and tire assemblies.

12. Remove jacks and road test car for proper brake action. Brakes must not be severely applied immediately after installation of reground brake shoes or

linings. Severe application may permanently damage new linings and may score brake drums. When linings are new, they must be given moderate use for several hundred miles of burnishing.

50-9 INSPECTING AND RECONDITIONING BRAKE DRUMS

Whenever brake drums are removed, they should be thoroughly cleaned and inspected for cracks, scores, deep grooves and out-of-round. Any of these conditions must be corrected since they can impair the efficiency of brake operation and cause premature failure of other parts.

A. Cracked, Scored, or Grooved Drum

A cracked drum is unsafe for further service and must be replaced. Do not attempt to weld a cracked drum.

Smooth up any slight scores by polishing with fine emery cloth. Heavy or extensive scoring will cause excessive brake lining wear, and it will probably be necessary to rebores in order to true up the braking surface.

If the brake linings are slightly worn and the drum is grooved, the drum should be turned just enough to remove grooves and the ridges in the lining should be lightly removed with a lining grinder.

If brake linings are more than half worn but do not need replacement, the drum should be polished with fine emery cloth but should not be turned. At this stage, eliminating all grooves in drum and smoothing the ridges on lining would necessitate removal of too much metal and lining, while if left alone, the grooves and ridges match and satisfactory service can be obtained.

If brake linings are to be replaced, a grooved drum should be turned for use with oversize linings (Subparagraph c, following). A grooved drum, if used with new lining, will not only wear the lining, but will make it difficult, if not impossible to obtain efficient brake performance.

B. Out-Of-Round of Tapered Drum

An out-of-round drum makes accurate brake shoe adjustment impossible and is likely to cause excessive wear of other parts of brake mechanism due to its eccentric action. An out-of-round drum can also cause severe and irregular tire tread wear as well as a pulsating brake pedal. When the braking surface of a brake drum exceeds the factory specification limits in taper (and/or) being out-of-round, the drum should be turned to true up the braking surface. Out-of round as well as taper and wear can be accurately measured with an inside micrometer fitted with proper extension rods.

When measuring a drum for out-of-round, taper and wear, take measurements at the open and closed edges of machined surface and at right angles to each other.

C. Turning Brake Drums

If a drum is to be turned, only enough metal should be removed to obtain a true, smooth braking surface. If a drum does not clean-up when turned to a maximum diameter as shown in the general specification, paragraph 50-15, it must be replaced. Removal of more metal will affect dissipation of heat and may cause distortion of the drum.

All brake drums have a maximum diameter cast into them. This diameter is the maximum wear diameter and not a refinish diameter. Do not refinish a brake drum that will not meet the specifications, as shown below, after refinishing.

ORIGINAL DIAMETER

A-Car	9.500
B-C-E-Car	11.000
Estate Wagon	12.000

MAXIMUM REBORE DIAMETER

A-Car	9.560
B-C-E-Car	11.060
Estate Wagon	12.060

DISCARD DIAMETER

A-Car	9.590
B-C-E-Car	11.090
Estate Wagon	12.090

A newly-turned drum should always have center contact with the shoes on initial break-in, thus ensuring greater uniformity in brake performance with less danger of brake pulling. To get this desired position the shoe radius should be .010" less than the drum radius (or .020" less on the diameter). This fit may be accomplished by either grinding the shoes or turning the drums, whichever is more practical.

Fit between the brake shoes and the drum must always be the same on both sides of the car to get equal braking action.

Brake drums may be refinished either by turning or grinding. Best brake performance is obtained by turning drums with a very finefeed. Too coarse a feed will cause a condition on the car called "shoe slap" in which the shoes attempt to follow the spiral of cut, then snap back against the backing plate. Ground and polished drums do not wear in as readily as turned drums and are more likely to cause unequal braking when new. To insure maximum lining life, the refinished braking surface must be smooth and free from chatter or tool marks.

D. Brake Drum Balance

During manufacture, brake drums are balanced within two ounce inches (4D-4F-4G-4H) and three ounce inches (4L-4N-4R-4P-4U-4V-4Y). These weights must not be removed.

After drums are turned, or if difficulty is experienced in maintaining proper wheel balance, it is recommended that brake drums be checked for balance. Brake drums may be checked for balance on most off-the-car wheel balancers.

50-10 FILLING, BLEEDING, AND FLUSHING BRAKE SYSTEM

A. Filling Brake Master Cylinder

The master cylinder must be kept properly filled to insure adequate reserve and to prevent air from entering the hydraulic system. However, because of expansion due to heat absorbed from brakes and from engine, master cylinder must not be overfilled.

The brake fluid reservoir is on the master cylinder which is located under the hood on the left side of the dash.

Thoroughly clean reservoir cover before removal to avoid getting dirt into reservoir. Remove cover and diaphragm. Add fluid as required to bring level to 1/4" (plus or minus 1/8") from the lowest portion of the top of each reservoir. Use Delco Supreme No. 11 Hydraulic Brake Fluid or equivalent.

Do not use shock absorber fluid or any other fluid which contains mineral oil. Do not use a container which has been used for mineral oil. Even a trace of mineral oil will cause swelling and distortion of rubber parts in the hydraulic brake system.

B. Bleeding Brake Hydraulic System

A bleeding operation is necessary to remove air whenever it is introduced into the hydraulic brake system. Since air is compressible and hydraulic fluid is not, the presence of air in the system is indicated by a

springy, spongy feeling of the brake pedal accompanied by poor braking action.

Air can be introduced into the hydraulic system if the brake pedal is operated when the fluid is too low in master cylinder reservoir. Air will also enter the system whenever any part of hydraulic system is disconnected.

It may be necessary to bleed the hydraulic system at all four wheel cylinders if air has been introduced through low fluid level or by disconnecting brake pipes at master cylinder. If brake pipe is disconnected at any wheel cylinder, then that wheel cylinder only need be bled. If pipes are disconnected at any fitting located between master cylinder and wheel cylinders, then all wheel cylinders served by the disconnected pipe must be bled. See paragraph 50-21 for bleeding disc brake cars.

On all power brake equipped models, the master cylinder and power brake unit is mounted at an angle on the dash. Two bleeder valves are located on the master cylinder. Because of the mounting angle, it will be necessary to bleed the master cylinder first and then the wheel cylinders whenever the master cylinder reservoir has become empty or whenever the master cylinder is removed from car.

C. Sequence for Bleeding Wheel Cylinders

It is advisable to bleed one wheel cylinder at a time to avoid allowing fluid level in reservoir to become dangerously low. The correct sequence of bleeding is to bleed wheel cylinder, either front or rear system, nearest master cylinder first. This sequence expels air from lines and wheel cylinders nearest to master cylinder first and eliminates possibility that air in a line close to master cylinder may enter a line farther away after it has been bled.

Do not perform bleeding operation while any brake drum is removed.

D. Bleeding Wheel Cylinder Without Pressure Tank

1. Fill master cylinder (subparagraph a above).
2. Install bleeder Wrench J-21472 on bleeder valve. Slip a brake bleeder tube over ball of wheel cylinder bleeder valve. Place lower end of bleeder tube in a glass jar that is partially filled with clean brake fluid. Position end of tube so that it will remain submerged under fluid during bleeding operation. Unscrew bleeder valve $3/4$ of a turn. See Figure 50- 9.

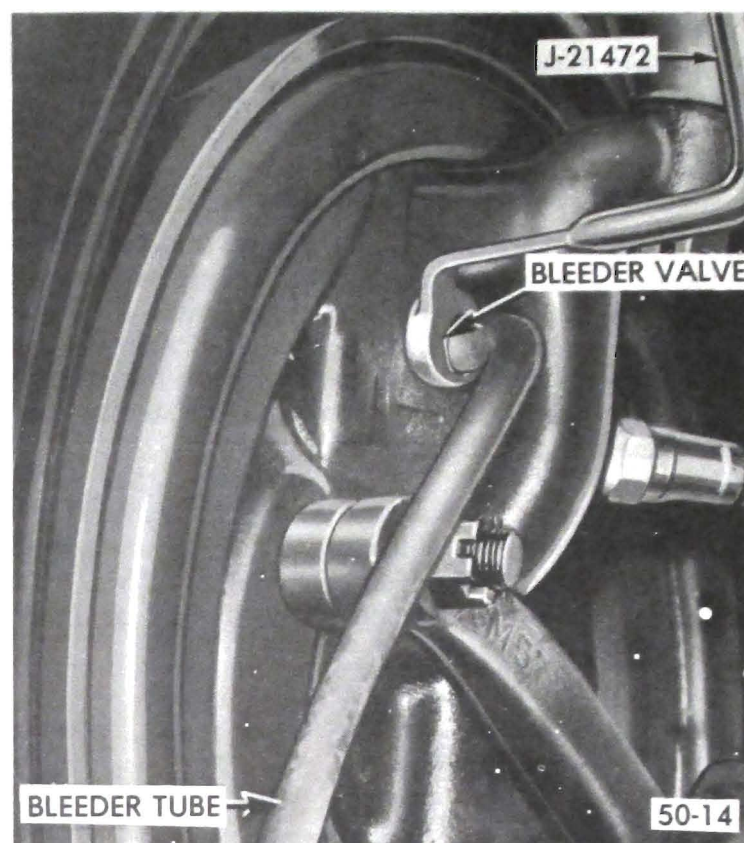

Figure 50-9 Bleeding Front Wheel Cylinder

3. Depress brake pedal a full stroke, close bleeder valve, and then allow pedal to return slowly to released position. Allowing pedal to return quickly may draw air into system. Continue operating pedal in this manner until fluid flows from bleeder tube into glass jar in a solid stream that is free of air bubbles, then close the bleeder valve securely and remove bleeder tube and wrench.
4. Frequently check master cylinder to make sure that it contains fluid. Allowing reservoir to be emptied will cause air to be drawn into hydraulic system.
5. When bleeding operation is completed at all wheel cylinders where needed, make sure that fluid level is $1/4$ " (plus or minus) $1/8$ " below lip of reservoir, then install rubber diaphragm and cover.
6. Discard the brake fluid deposited in glass jar during bleeding operation. It is poor economy to attempt to clean fluid that has once been used.

E. Bleeding Wheel Cylinder With Pressure Tank

When using a pressure tank, air bubbles may form in the tank and enter the brake hydraulic system. To avoid this, observe the following points when handling a pressure tank: (1) Do not shake or agitate the pressure tank after air pressure has been added or is

being added. (2) Allow pressure tank to stand in one position as much as possible and bring air hose over to tank when adding head of air. (3) Make certain the valves on the pressure tank lines are not defective allowing air to be sucked in when fluid passes through the lines. (4) Pressure tank should be kept at least 1/3 full of fluid to avoid air bubbles forming, (5) If pressure tank is full of air bubbles, release air pressure and those bubbles will increase in size, be forced to top of fluid and escape.

It is recommended that pressure bleeding equipment must be of the diaphragm type; that is, it must have a rubber diaphragm between the air supply and the brake fluid to prevent air, moisture, oil, and other contaminants from entering the hydraulic system.

1. Thoroughly clean master cylinder reservoir cover and surrounding area; then remove cover and diaphragm.

2. Make sure that pressure tank is at least 1/3 full of specified brake fluid and that hose and master cylinder reservoir are filled with fluid. Attach hose to master cylinder reservoir adapter J-23518.

3. Install Bleeder Wrench J-21472 on bleeder valve. Slip a brake bleeder tube over ball of wheel cylinder bleeder valve. Place lower end of bleeder tube in a clean glass jar. Unscrew bleeder valve 3/4 of a turn.

4. Open pressure tank hose valve to apply fluid to master cylinder under pressure that does not exceed 35 pounds. It is not necessary to pump the brake pedal when using pressure tank.

5. When fluid flows from bleeder tube into glass jar in a solid stream that is free of air bubbles, that particular cylinder and line are bled; tighten bleeder valve securely and remove bleeder tube.

6. When bleeding operation is completed at all wheel cylinders, where needed, make sure that fluid level is 1/4" (plus or minus 1/8") from the lowest portion of the top of each reservoir. Install rubber diaphragm and cover.

F. Flushing Brake Hydraulic System

It is recommended that the entire hydraulic system be thoroughly flushed with clean brake fluid whenever new parts are installed in the hydraulic system.

Flushing is also recommended if there is any doubt as to the grade of fluid in the system or if fluid has been used which contains the slightest trace of mineral oil.

Flushing is performed at each wheel cylinder in turn, and in the same manner as the bleeding operation except that bleeder valve is opened 1-1/2 turns and the

fluid is forced through the pipes and wheel cylinder until it emerges clear in color. Approximately one quart of fluid is required to flush the hydraulic system thoroughly.

When flushing is completed at all wheel cylinders, make certain that master cylinder reservoir is filled to proper level.

50-11 WHEEL BOLT REMOVAL AND INSTALLATION

A. Drum Brakes

The wheel bolts are pressed into the front hub and drum assembly, forming a shoulder on each bolt by a swaging operation. See Figure 50-10. To replace a wheel bolt, the original bolt should not be pressed out of the hub, since the swaged shoulder will enlarge the wheel bolt opening. This will make it impossible to install a new wheel bolt tightly and will require brake drum replacement.

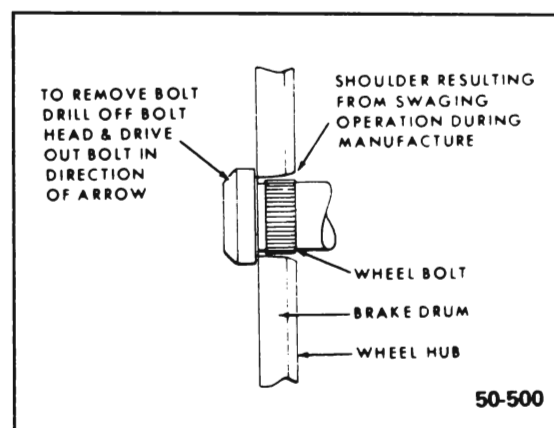

Figure 50-10 Bolt Pressed Into Place

1. Remove hub and drum assembly from car.
2. Secure hub and drum assembly in a vise and mark center of the bolt head with a center punch. Drill 1/8" pilot hole in head of bolt; redrill head using a 9/16" bit. Cut off any remaining portion of bolthead using a chisel and then drive out bolt with drift. See Figure 50-10.
3. Press new wheel bolt into place in drum and reinstall assembly onto car.
4. Refer to Group 30 for correct wheel bearing adjustment.

B. Disc Brakes

1. Remove hub and rotor assembly from car.
2. Mark rotor to hub location and remove five (5) bolts attaching hub to rotor.

3. The wheel bolts on disc brakes can be pressed out from the outside of the hub and installed from inside the rotor by pressing into place. *No drilling or cutting is required.*

4. Reinstall assembly and adjust wheel bearings as stated in Group 30.

DIVISION V

OVERHAUL AND MAJOR SERVICE

50-12 WHEEL CYLINDER OVERHAUL

A. Removal of Brake Wheel Cylinder

1. Remove wheel, drum, and brake shoes. Be careful not to get grease or dirt on brake lining.

Remove wheel cylinder from backing plate.

B. Disassembly of Brake Wheel Cylinder

1. Pull boots from cylinder ends and discard boots.

2. Remove and discard pistons and cups.

C. Inspection of Brake Wheel Cylinder

1. Inspect cylinder bore for scoring or corrosion. It is best to replace a corroded cylinder. Staining is not to be confused with corrosion. Corrosion can be identified as pits or excessive roughness.

2. Polish any discolored or stained area with crocus cloth by revolving cylinder on cloth supported by a finger. Do not slide cloth in a lengthwise manner under pressure. Do not use any other form of abrasive or abrasive cloth.

3. Rinse cylinder in DeClene or clean brake fluid.

4. Shake excessive rinsing fluid from cylinder. Do not use a rag to dry cylinder, as lint from the rag cannot be kept from cylinder bore surfaces.

D. Assembly of Brake Wheel Cylinder

1. Lubricate cylinder bore and counterbore with clean brake fluid and insert spring-expander assembly.

2. Install new cups. (Be sure cups are lint and dirt free). Do not lubricate cups prior to assembly.

3. Install new Durex pistons in the "as Received" condition--do not lubricate pistons with brake fluid. Always use new Durex pistons to insure proper corrosion inhibiting properties.

4. Press new boots into cylinder counterbores by hand. Do not lubricate boots prior to assembly.

E. Installation of Brake Wheel Cylinder

1. Install wheel cylinder on brake backing plate and connect brake pipe or hose. Torque front wheel brake hose to wheel cylinder to 28 lb. ft. Torque rear wheel brake pipe to wheel cylinder to 100 lb. in.

2. Install brake shoes, drum and wheel; then flush and bleed hydraulic system (Paragraph 50-10).

50-13 PARKING BRAKE CABLE REPLACEMENT

A. Front Parking Brake Cable Replacement

1. Raise car.

2. Remove jam nut and adjusting nut from equalizer. See Figures 50-17 or 18.

3. Remove retainer clip from rear portion of front cable at frame on 4D-4F-4G-4H and from lever arm on 4L-4N-4R-4P-4U-4V-4Y Series cars.

4. Using a pair of pliers, bend snap-in retainer fingers in, so that cable can be removed on 4D-4F-4G- 4H Series cars.

5. Disconnect front brake cable from parking brake pedal assembly. Remove front brake cable. On some models it may assist installation of new cable if a heavy cord is tied to either end of cable in order to guide new cable through proper routing.

6. Install cable by reversing removal procedure.

7. Adjust parking brake as detailed in paragraph 50- 6.

B. Center Parking Brake Cable Replacement

1. Raise car.

2. Remove jam nut and adjusting nut from equalizer.

3. Unhook connector at each end and disengage hooks and guides.

4. Install new cable by reversing removal procedure.

5. Adjust parking brake as detailed in Paragraph 50- 6.

6. Apply parking brake three (3) times with heavy pressure and repeat adjustment.

C. Rear Parking Brake Cable Replacement

1. Raise car.
2. Remove rear wheel and brake drum.
3. Loosen jam nut and adjusting nut at equalizer.
4. Disengage rear cable at connector.
5. Remove two bolts attaching cable assembly to backing plate (4R). Bend retainer fingers (4D-4F-4G-4H-4L-4N-4P-4U-4V-4Y).
6. Disengage cable at brake shoe operating lever.
7. Install new cable by reversing removal procedure.
8. Adjust parking brake as detailed in paragraph 50- 6.

50-14 MASTER CYLINDER OVERHAUL

The dual master cylinder is designed and built to satisfy individual brake system displacement requirements for each car model. Therefore, it is necessary that when replacing either complete master cylinder assemblies or the component pistons of these assemblies, it is imperative that the exact replacements be used.

The length of the component pistons in the master cylinders are critical factors in displacement capabilities of a particular master cylinder. These pistons are coded, using rings or grooves in the shank of the piston. It is mandatory that when pistons are replaced, the replacing piston must contain the same identification marks and the same contour at the push rod end as the piston which was removed.

A. Removal of Brake Master Cylinder

1. Disconnect brake pipes from master cylinder and tape end of pipes to prevent entrance of dirt.
2. (Manual brake only) Disconnect brake pedal from master cylinder push rod by removing retainer clip and clevis pin on 4D-4F-4G-4H Series less Sportwagon. See Figure 50-22.
3. Remove two nuts holding master cylinder to dash or power cylinder and remove master cylinder from car. Be careful not to drip brake fluid on exterior paint.

B. Disassembly of Brake Master Cylinder

1. Clean outside of master cylinder thoroughly. Remove reservoir cover and diaphragm. Turn cylinder over and pump push rod by hand to drain all brake fluid. Always discard used fluid.

2. (Manual brake only) Pull boot away from master cylinder to uncover push rod retainer. The retainer has a small, depressed tab in the side. This tab may be pried up to release retainer. This tab serves only to hold retainer and push rod on master cylinder, while it is being shipped. The tab does not have to be bent down again at reassembly, because retainer is held in place between master cylinder and dash when master cylinder is bolted to car.

3. Depress piston and remove secondary piston stop bolt from bottom of front fluid reservoir.

4. Place master cylinder in a vise so that lock ring can be removed from groove in the inside diameter of bore. Remove lock ring and primary piston assembly. Remove secondary piston, secondary piston spring and retainer by blowing air through the stop bolt hole. If no air is available, a piece of wire may be used. Bend about one fourth inch (1/4") of one end into a right angle. Hook this end under edge of the secondary piston and pull it out.

5. Place master cylinder in vise, so that outlet holes are up. Enlarge hole in tube fitting insert using a 13/64" drill. Place a heavy washer over outlet on master cylinder and thread a 1/4-20 x 3/4" screw into the insert. Tighten screw until insert is unseated. Remove insert, screw, and washer.

6. Remove primary seal, primary seal protector and two secondary seals from secondary piston.

7. Use Declene or clean brake fluid to clean all metal brake parts thoroughly. Immerse in cleaning fluid and brush with hair brush to remove foreign matter. Air dry and place cleaned parts on clean paper or lint free clean cloth.

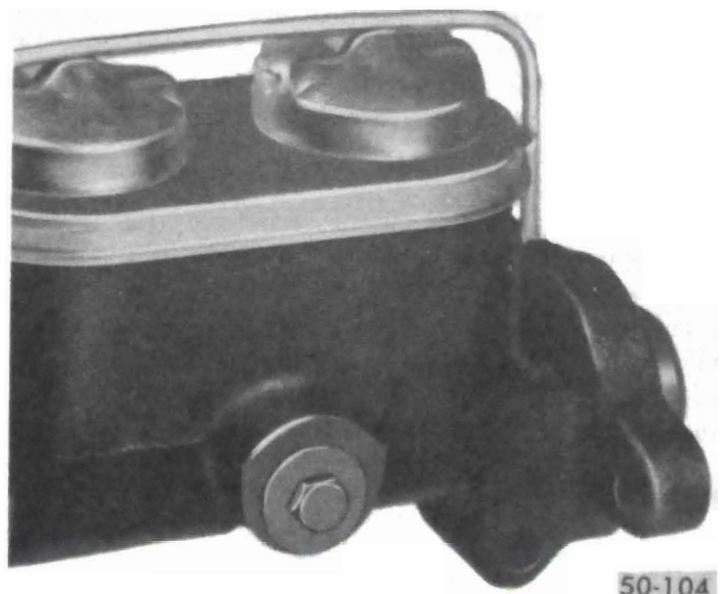

Figure 50-12 Remove Tube Seat

Do not use anti-freeze alcohol, gasoline, kerosene, or any other cleaning fluid that might contain even a trace of mineral oil.

Dirt is the major cause of trouble and wear in service. Be sure to keep parts clean until reassembly. Rewash at reassembly, if there is any occasion to doubt cleanliness.

C. Inspection of Brake Master Cylinder

Inspect cylinder bore for scoring or corrosion. It is best to replace a corroded cylinder. Staining is not to be confused with corrosion. Corrosion can be identified as pits or excessive roughness.

Polish any discolored or stained area with crocus cloth by revolving cylinder on cloth supported by a finger. Do not slide cloth in a lengthwise manner under pressure. Do not use any other form to abrasive of abrasive cloth.

Rinse cylinder in Declene or clean brake fluid.

Shake excess rinsing fluid from cylinder. Do not use a rag to dry cylinder, as lint from rag cannot be kept from cylinder bore surfaces.

Make certain that compensating port in cylinder is clear; however, do not run a wire through the port as this may leave a burr which will cut a groove in primary cup.

If scratches or corroded spots are too deep to be polished satisfactorily, the cylinder should be replaced since honing is not recommended and oversize pistons and cups are not furnished for service.

The master cylinder bore has a hard, highly polished "bearingized" surface produced by diamond boring followed by rolling under very heavy pressure. Honing destroys the bearingized surface leaving a softer and rougher surface which will cause more rapid wear of piston and rubber cups. Higher friction produced by the rougher surface will also reduce braking power for a given pressure on brake pedal.

The maximum allowable clearance between piston and cylinder bore is .0055". If this clearance is increased by honing, the heavy pressure of brake fluid may force the rubber of the cup into the clearance and cause sticking or early failure of this cup. If a choice must be made between honing or replacement of the cylinder, it must be remembered that while a new cylinder may be more expensive, a honed cylinder may not give a satisfactory length of service.

D. Assembly of Brake Master Cylinder

1. Place brass tube fitting insert (new parts) in outlet holes, so that it is in a position to be pressed into outlet hole. Be sure that it is not cocked, as this would cause burrs to be turned up when tube fitting insert is pressed in. The recommended method of inserting tube fitting insert is to thread a spare brake line tube nut into outlet hole and turn nut down until tube fitting insert bottoms. Remove tube nut and check outlet hole for loose burrs, which might have been turned up when tube fitting insert was pressed down.

2. Put new secondary seals in two grooves in end of secondary piston. The seal which is nearest the end will have its lip facing toward that end. The seal in the second groove should have its lip facing toward the portion of the secondary piston, which contains the compensating holes.

3. Assemble a new primary seal protector and primary seal over end of secondary piston, so that flat side of the seal seats against the seal protector and the protector against flange of piston which contains the compensating holes.

4. Assemble new secondary seal into groove on push rod end of the primary piston. The lip of seal should face toward the compensating holes in opposite end of primary piston.

5. In order to insure correct assembly of the primary assembly, a complete primary piston assembly is included in the repair kits.

6. Remove all cleaning liquid from threaded hole in primary piston. Place piston extension screw down through secondary piston stop and primary spring retainer. Tighten screw into primary piston until it bottoms. Torque to 80-100 lb. in.

7. Coat bore of master cylinder with clean brake fluid. Coat primary and secondary seals on secondary piston with clean brake fluid. Insert the secondary piston spring retainer into secondary piston spring. Place retainer and spring over end of secondary piston, so that retainer locates inside lip of primary cup.

8. Hold master cylinder with open end of bore down, push secondary piston into bore, so that spring will seat against closed end of bore.

9. Place master cylinder in a vise with open end of bore up. Coat primary and secondary seal on primary piston with clean brake fluid. Push primary piston assembly, spring end first, into bore of master cylinder.

Hold the piston down and snap lock ring into position in groove in inside diameter of bore.

10. Continue to hold primary piston down. This will also move the secondary piston forward. The secondary piston will now be forward far enough to clear stop screw hole, which is in bottom of front fluid reservoir.

11. Install a new reservoir diaphragm in reservoir cover, where needed, and install cover on master cylinder. Beaded side faces master cylinder casting to insure positive sealing. The bail wire is now pushed into position to hold reservoir cover.

12. (Manual brake only.) Assemble push rod through push rod retainer, if it has been disassembled. Push retainer over end of master cylinder. Assemble new boot over push rod and press it down over the push rod retainer. Thread jam nut down to shoulder on push rod. Thread clevis down to jam nut. Torque nut against clevis to 14 lb. ft.

CAUTION: *This brake pedal to master cylinder clevis fastener is an important attaching part in that it could affect the performance of vital components and systems, and/or could result in major repair expense. It must be replaced with one of the same part number, or with an equivalent part, if replacement becomes necessary. Do not use a replacement part of lesser quality or substitute design. Torque values must be used as specified during reassembly to assure proper retention of this part.*

E. Installation of Brake Master Cylinder

1. Install master cylinder on dash or power cylinder. Torque nuts to 24 lb. ft.

CAUTION: *This brake master cylinder to cowl fastener is an important attaching part in that it could affect the performance of vital components and systems, and/or could result in major repair expense. It must be replaced with one of the same part number, or with an equivalent part, if replacement becomes necessary. Do not use a replacement part of lesser quality or substitute design. Torque values must be used as specified during reassembly to assure proper retention of this part.*

2. (Manual brake only.) Connect push rod to brake pedal by installing clevis pin and retainer clip on 4D-4F-4G-4H Series less Sportwagon.

3. Connect brake pipes to master cylinder. Outlet boss thread sizes for front and rear are different, as are brake line fittings. This will insure that correct connections are made, provided original brake lines have not been changed.

4. Bleed hydraulic system as described in paragraph 50-10. The master cylinder is now bled as though it were two separate master cylinders. (4D-4F-4G-4H series, power brakes only, bleed master cylinder first, then bleed wheel cylinders). Bleed wheel cylinders nearest to master cylinder first and check for proper

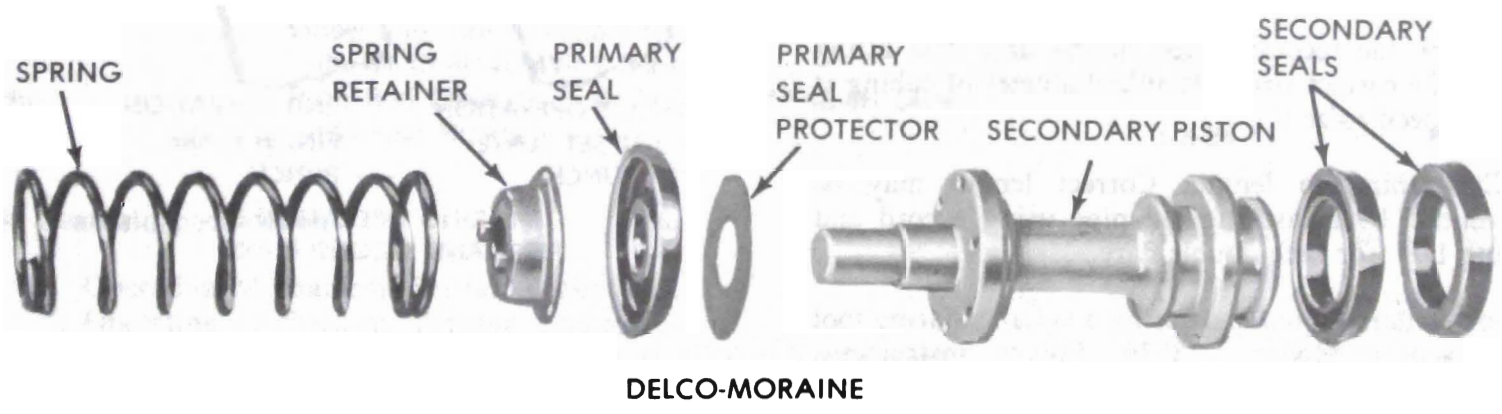

50-106A

Figure 50-14 Secondary Piston - Exploded View

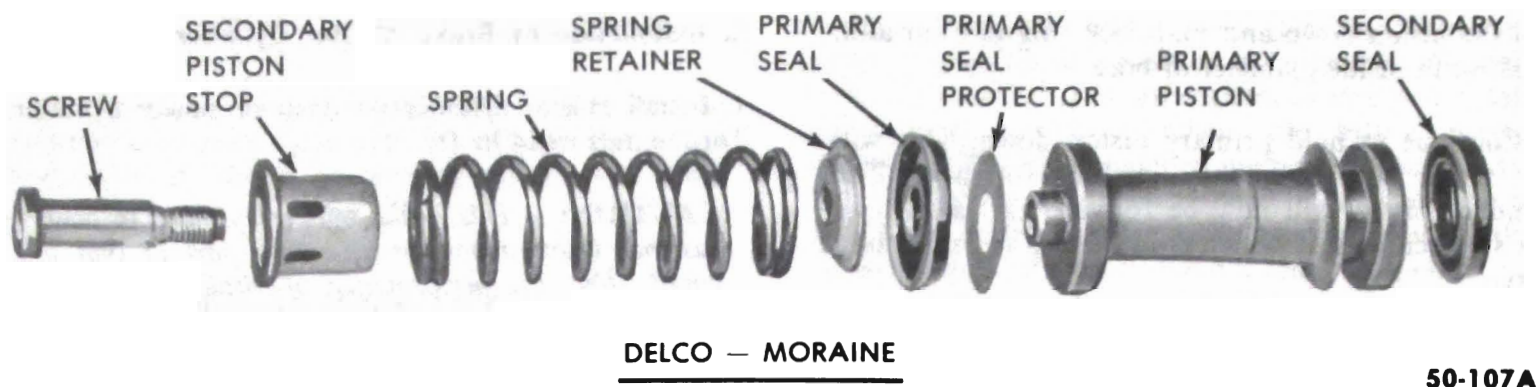

Figure 50-15 Primary Piston - Exploded View

pedal feel. If system has air in it, bleed other wheel cylinders. After bleeding, bring fluid to 1/4" (plus or minus) 1/8" below lip of reservoir opening.

5. Road test car for proper brake performance. (Division IV).

50-15 REPLACING BRAKE PIPES

Since brake pipe assemblies (except master cylinder outlet pipes to combination valve) are not available from Buick Parts Warehouses, it is therefore necessary to order service bulk tubing and fittings to make-up any pipe assembly which is needed. All brake pipes must be made of tin plated or copper coated wrapped steel tubing with the ends double flared.

WARNING: Never use copper tubing because copper is subject to fatigue cracking which would result in brake failure.

To make up a brake pipe assembly, proceed as follows:

1. Procure the recommended tubing and steel fitting nuts of the correct size. (Outside diameter of tubing is used to specify size.)
2. Cut tubing to length. Correct length may be determined by measuring old pipe using a cord and adding 1/8" for each double flare.
3. Double flare tubing ends using a suitable flaring tool such as Kent-Moore J-23530. Follow instructions included in tool set.

Make sure fittings are installed before starting second flare.

WARNING: Double flaring tool must be used as single flaring tools cannot produce a flare strong enough to hold the necessary pressure.

4. Bend pipe assembly to match old pipe using a tubing bender. Clearance of .750 must be maintained to all moving or vibrating parts.

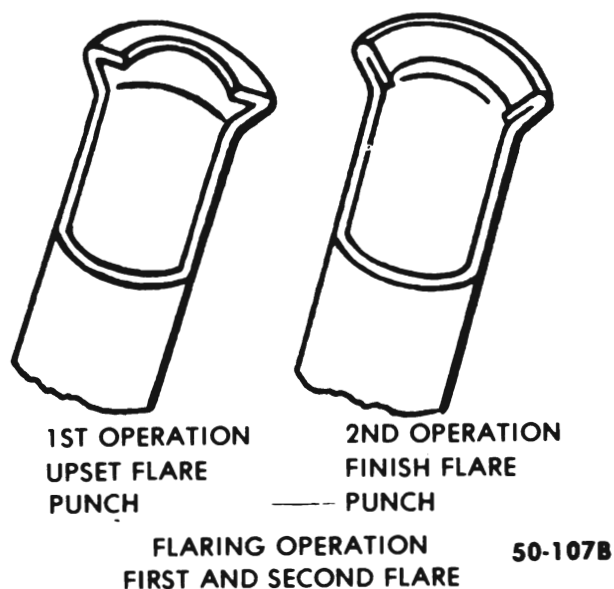

Figure 50-16

DIVISION VI

SPECIFICATIONS

50-16 BRAKE SPECIFICATIONS

A. Tightening Specifications

Use a reliable torque wrench to tighten the parts listed, to insure proper tightness without straining or distorting parts. These specifications are for clean and lightly-lubricated threads only; dry or dirty threads produce increased friction which prevents accurate measurement of tightness.

Part	Location	Thread	Torque
		Size	Lb.Ft.
Nut	Brake Cylinder and Pedal Mounting Bracket to Dash	3/8-16	24
Nut	Push Rod Clevis Locking - 4D-4F-4G-4H Series (Power Brakes)	3/8-24	14
Nut	Brake Pedal and Clutch Pedal Pivot Shaft to Mounting Bracket - 4D-4F-4G-4H Series	7/16-14	25
Nut	Parking Brake Mounting to Dash	5/16-18	72-180 Lb.In.
Screw	Parking Brake Mounting to Instrument Panel	1/4-20	90 Lb.In.
Nut	Parking Brake Front Cable to Equalizer	5/16-18	5
Bolt	Wheel Cylinder to Backing Plate Mounting - 4L-4N-4R-4P-4U-4V-4Y Series	5/16-18	200 Lb.In.
Bolt and Nut	Front Brake Assembly and Steering Arm to Knuckle - 4D-4F-4G-4H Series	1/2-20	85
Bolt and Nut	Front Brake Assembly and Steering Arm to Knuckle - 4L-4N-4P-4R-4U-4V-4Y Series	1/2-13	80
Bolt	Front Brake Anchor Pin - 4D-4F-4G-4H Series	1/2-20	93
Bolt and Nut	Rear Brake Assembly to Axle Housing	3/8-24	35
Nut	Wheel and Tire Assembly to Drum - 4D-4F-4G-4H Series	7/16-20	70
Nut	Wheel and Tire Assembly to Drum - 4L-4N-4R-4P-4U-4V-4Y Series	1/2-20	75
Nut	Push Rod Clevis to Push Rod - 4D-4F-4G-4H Series (Manual Brakes)	3/8-24	14

B. General Specifications

Operating Mechanism, Service Brake	Hydraulic
Operating Mechanism, Parking Brakes	Lever and Cables
Operation of Service Brakes Independent of Parking Brakes	Yes
Wheels Braked, Service	Front and Rear
Wheels Braked, Parking	Rear Only
Brake Pedal Height Adjustment	None
Brake Drum Type, Front - 4D-4F-4G-4H Series	Composite Cast Iron
Brake Drum Type, Rear - All Series	Composite Cast Iron
Master Cylinder Piston Diameter, Drum Brakes	1"
Master Cylinder Piston Diameter, Disc Brakes	1-1/8"

Wheel Cylinder Size Front - 4D-4F-4G-4H Series	1-1/8"
Wheel Cylinder Size Rear - 4D-4F-4G-4H Series	7/8"
Wheel Cylinder Size Front - All Series Disc Brakes	2-15/16"
Wheel Cylinder Size Rear - 4L-4N-4P-4U-4V Series	15/16"
Wheel Cylinder Size Rear - 4Y Series	15/16"
Wheel Cylinder Size Rear - 4R Series	1"
Approved Hydraulic Brake Fluid	GM or Delco Supreme No. 11 or Equiv.
Fluid Level, From Lowest Portion of Top of Each Reservoir	1/4±1/8"
Brake Drum Inside Diameter, New - 4D-4F-4G-4H Series	9.495-9.505"
Brake Drum Inside Diameter, Rear Only - 4L-4N-4P-4U-4V Series	10.997-11.007"
Brake Drum Inside Diameter, Rear Only - 4R Series	11.997-12.007"
Brake Shoe Lining Length x Width	
4D-4F-4G-4H Front (Drum Brakes)	Primary 7.65" x 2.50"
4D-4F-4G-4H Front (Drum Brakes)	Secondary 9.92" x 2.50"
4D-4F-4G-4H Rear	Primary 7.65" x 2.00"
4D-4F-4G-4H Rear	Secondary 9.92" x 2.00"
4L-4N-4P-4U-4V-4Y Rear	Primary 8.93" x 2.00"
4L-4N-4P-4U-4V-4Y Rear	Secondary 11.58" x 2.00"
4R Rear	Primary 9.90" x 2.00"
4R Rear	Secondary 12.85" x 2.00"
Brake Drum Rebore, Max. Allowable Inside Diameter	
4D-4F-4G-4H Series	9.590"
4L-4N-4P-4U-4V-4Y Series	11.090"
4R Series	12.090"
Max. Allowable Taper - All Series003"
Max. Allowable Out-of-Round - 4L-4N-4R-4P-4U-4V-4Y Series002"
4D-4F-4G-4H Series	Front .001", Rear .0005"
Max. Allowable Out-of-Round of Drum - 4D-4F-4G-4H Series	2 Oz.In.
Max. Allowable Out-of-Round of Drum - 4L-4N-4R-4P-4U-4V-4Y Series	3 Oz.In.
Max. Allowable Space Between Lining and Shoe Rim After Riveting005"

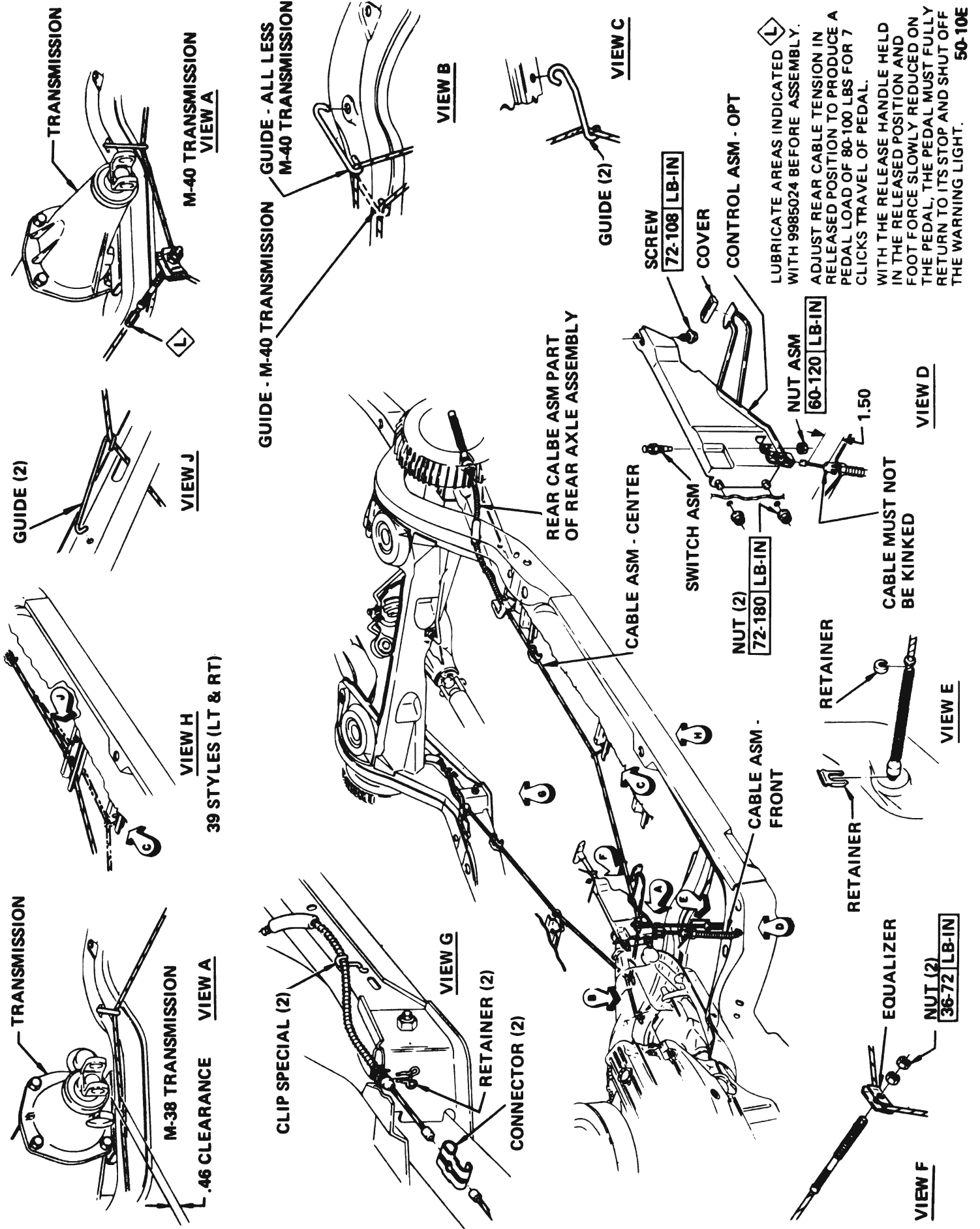

Figure 50-17 Parking Brake Control System - 4D-4F-4G-4H

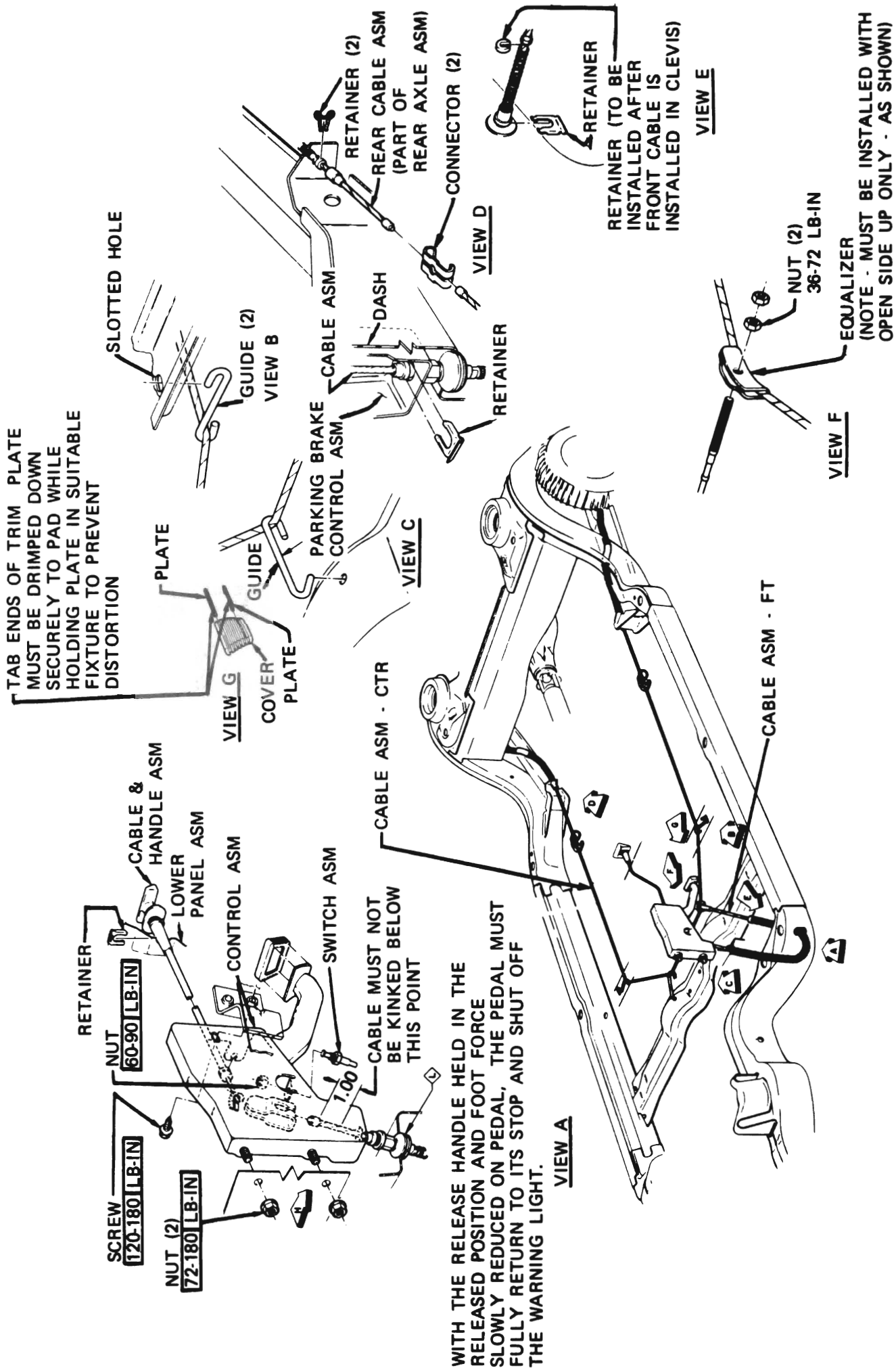

Figure 50-18 Parking Brake Control System - 4L-4N-4R-4P-4U-4V-4Y

DRUM BRAKE, PARKING BRAKE, WHEEL CYLINDER AND MASTER CYLINDER - ALL SERIES 50-25

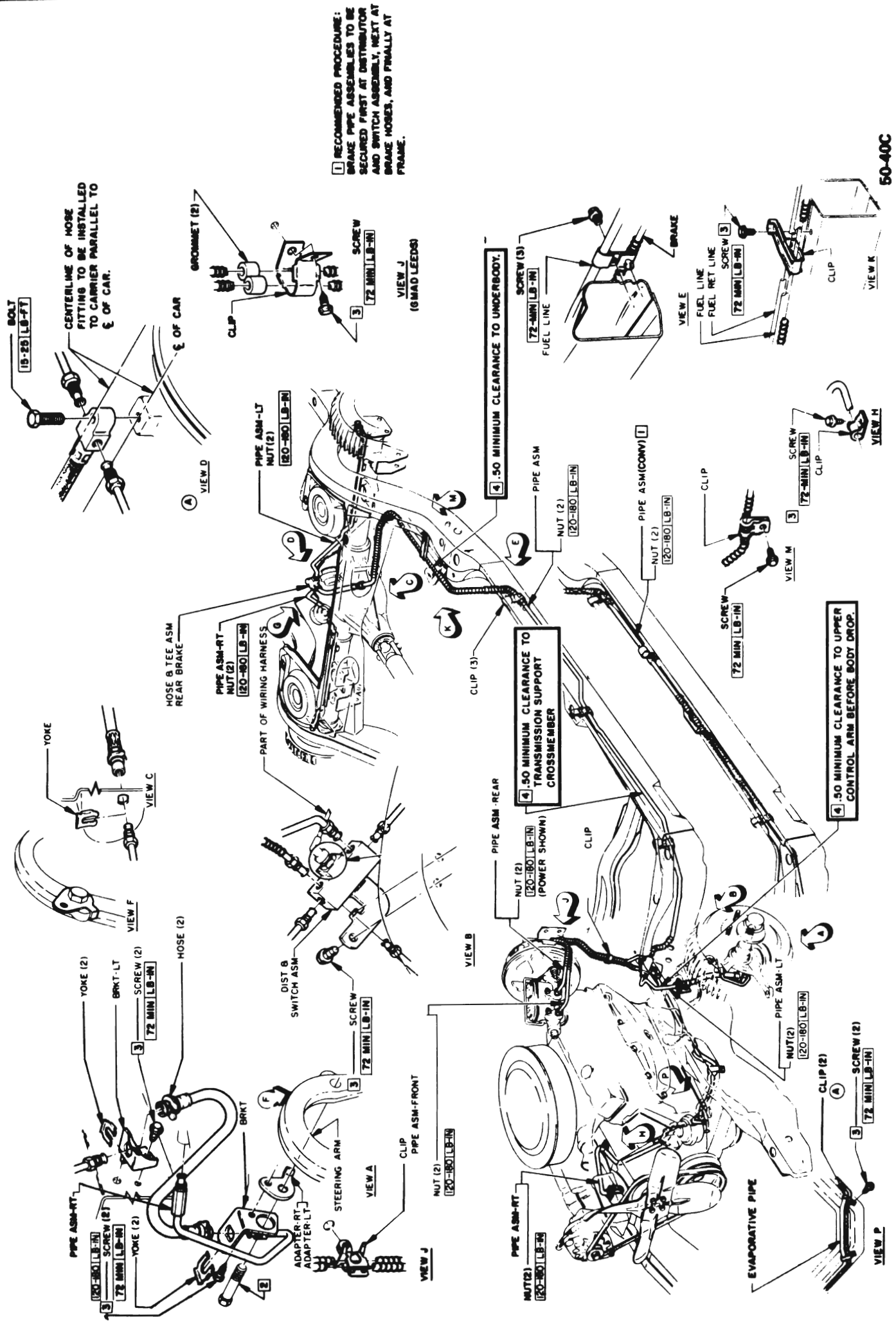
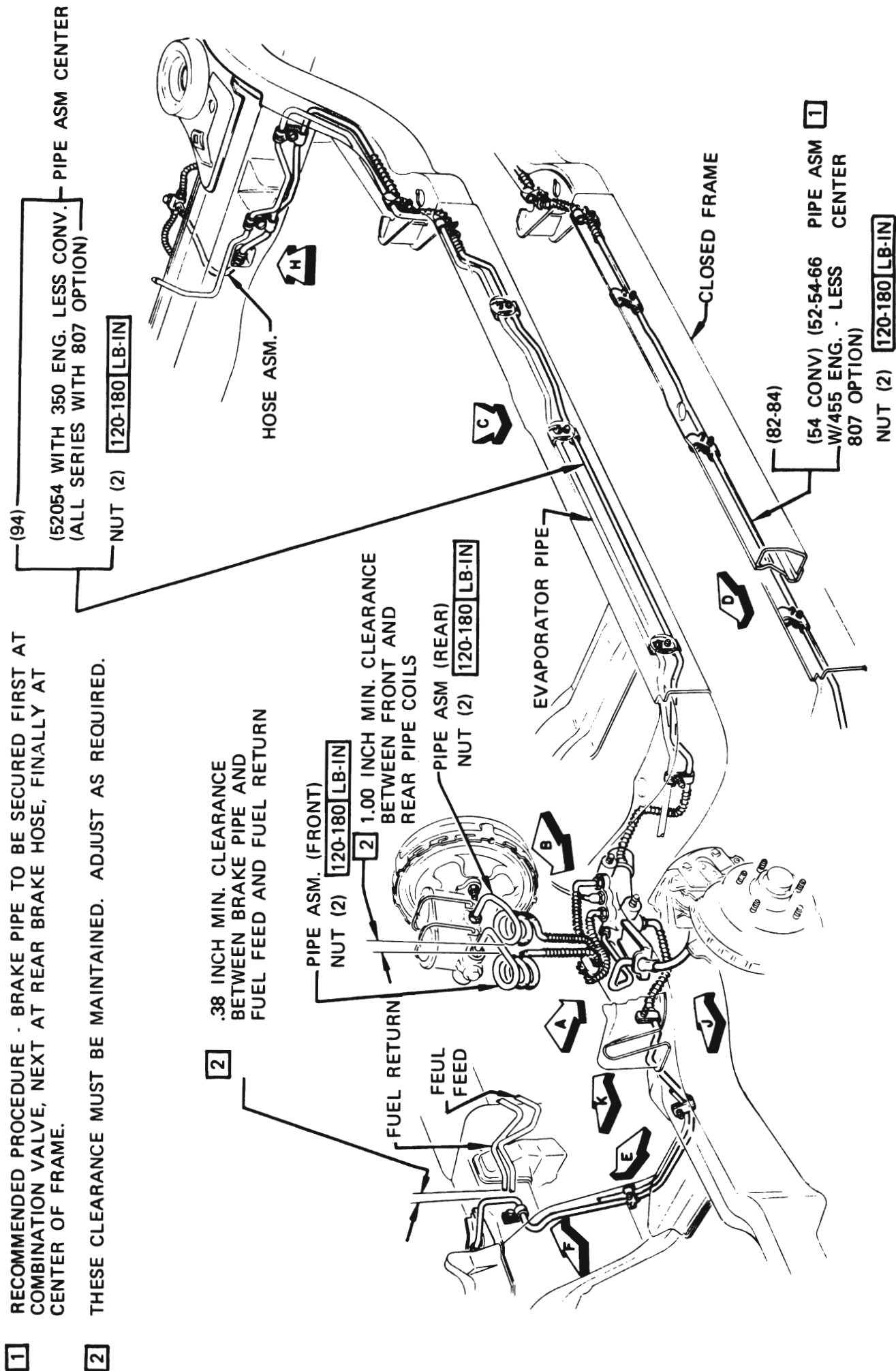
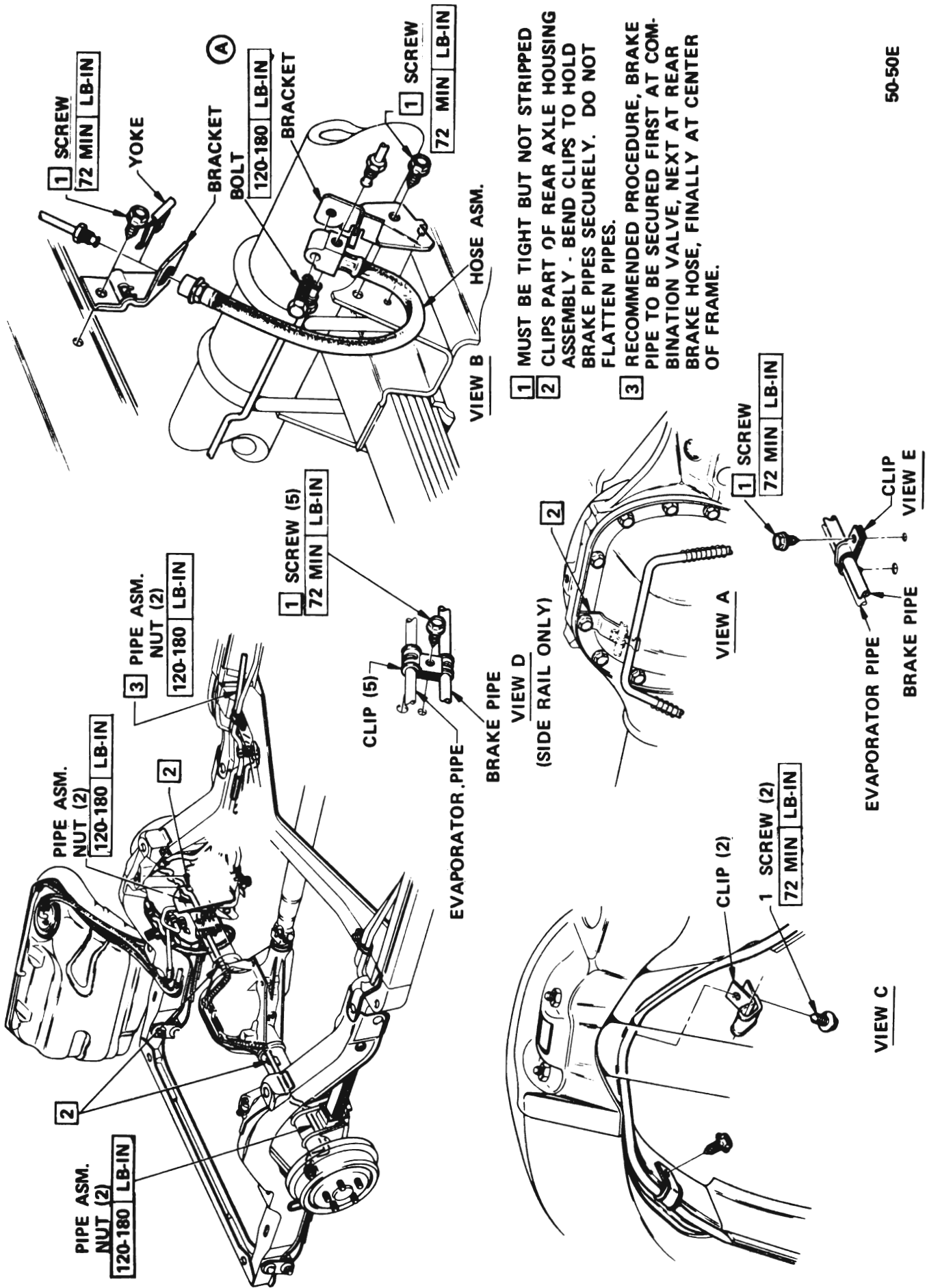

Figure 50-19 Service Brake Control System - 4D-4F-4G-4H



50-50C

Figure 50-20 Service Brake Control System - 4L-4N-4R-4P-4U-4V-4Y



50-50E

Figure 50-21 Service Brake Control System - Estate Wagon

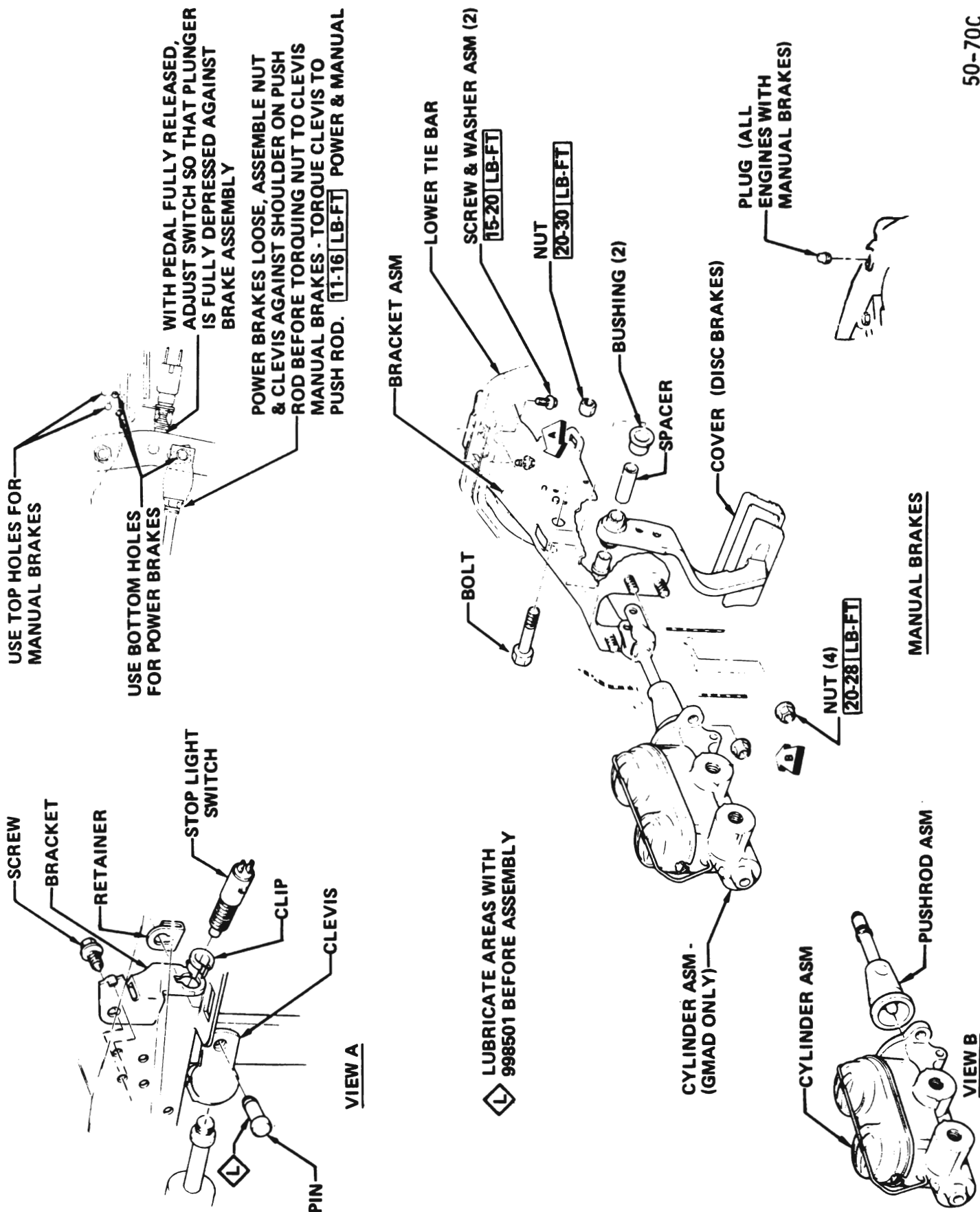

Figure 50-22 Manual Brake Master Cylinder Mounting - 4D-4F-4G-4H

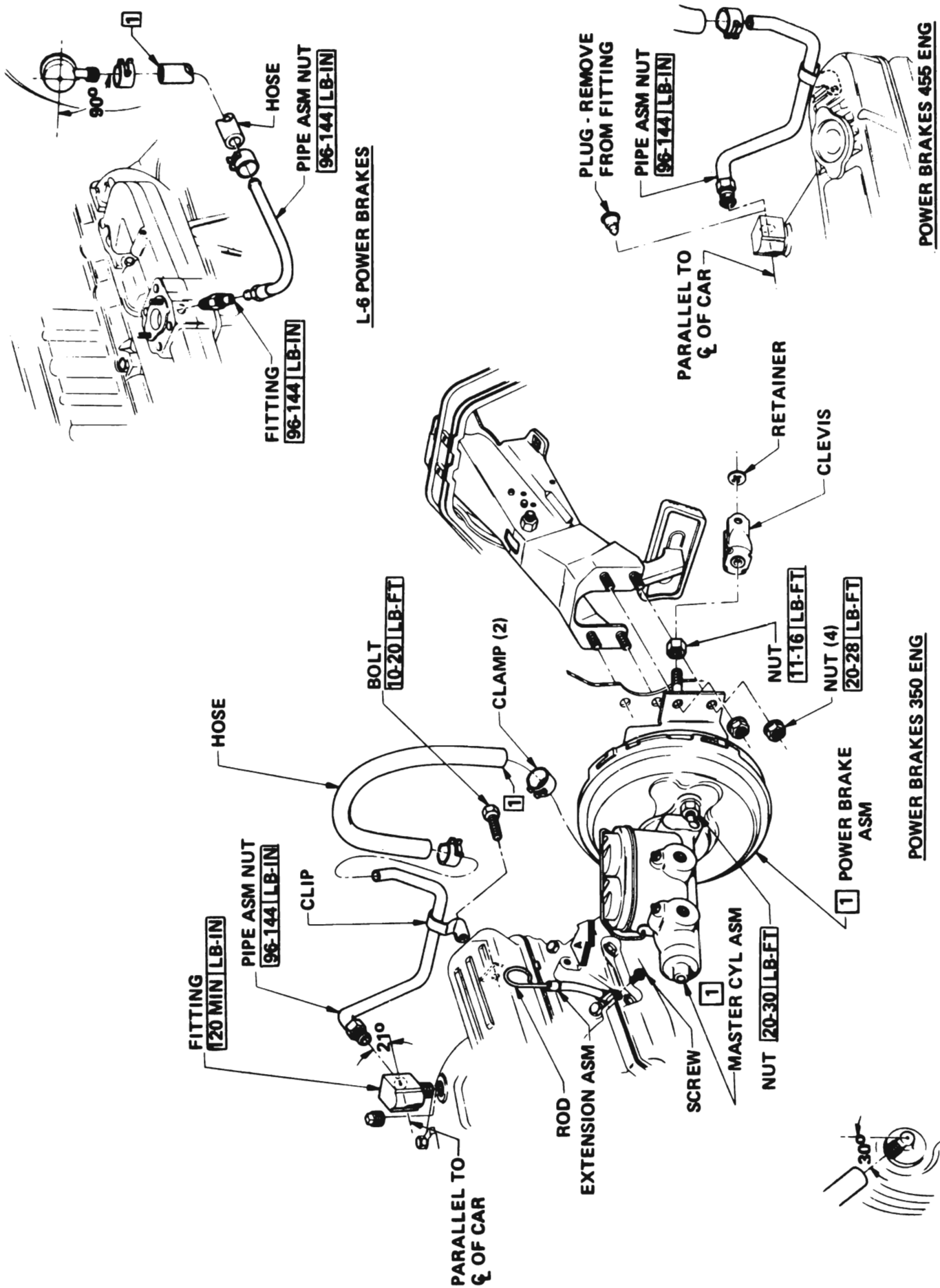
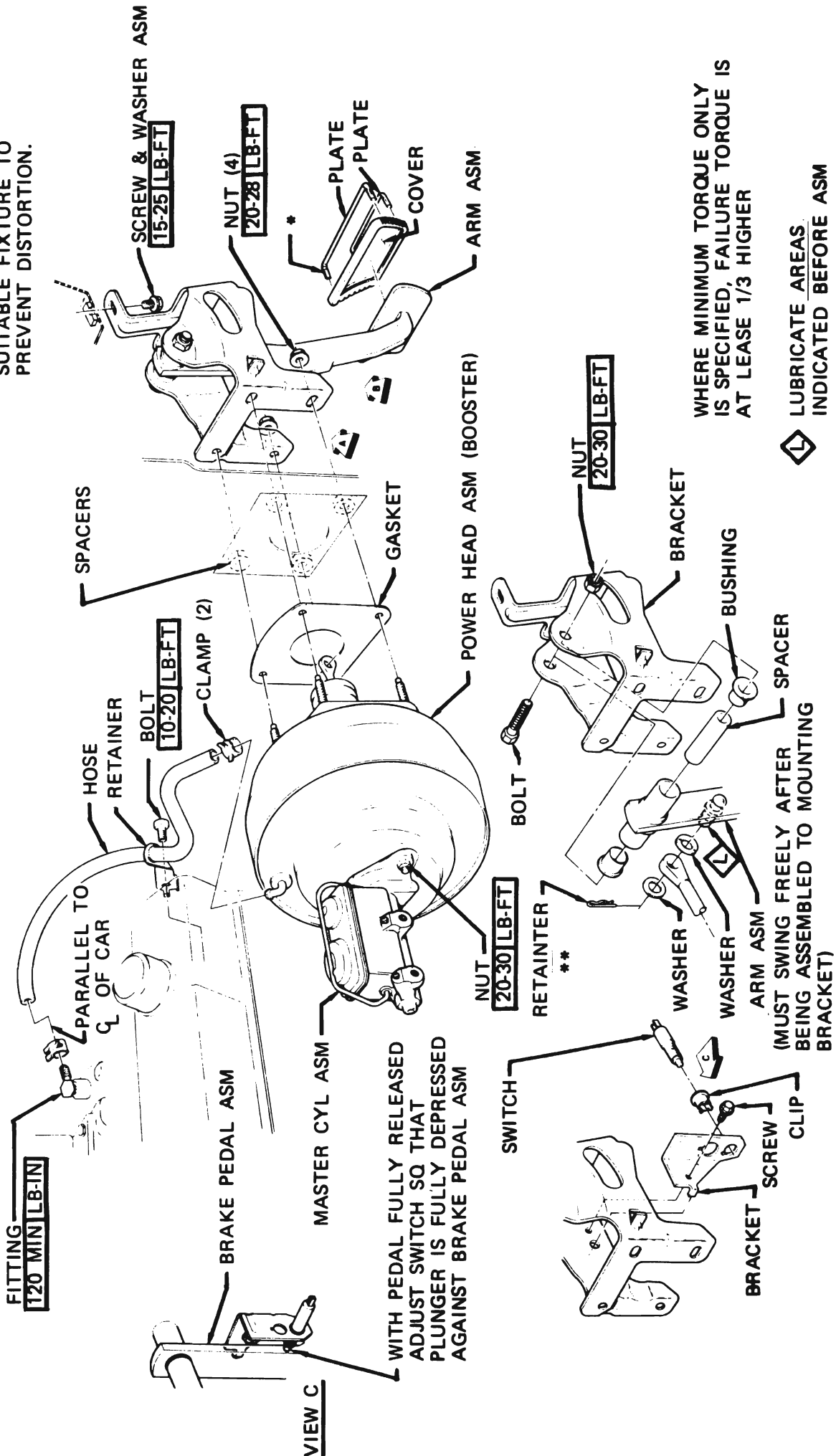

Figure 50-23 Power Brake Master Cylinder Mounting - 4D-4F-4G-4H

* TAB ENDS ON TRIM PLATES MUST BE CRIMPED DOWN SECURELY TO PAD WHILE HOLDING PLATE IN A SUITABLE FIXTURE TO PREVENT DISTORTION.



** (INSTALLATION DIRECTIONS OPT)

Figure 50-24 Power Brake Master Cylinder Mounting - 4L-4N-4R-4P-4U-4V-4Y

DRUM BRAKE, PARKING BRAKE, WHEEL CYLINDER AND MASTER CYLINDER - ALL SERIES 50-31

- 1** ASSEMBLY PROCEDURE
- 1- ENGAGE THREADS OF BOLT IN STEERING KNUCKLE BY HAND.
 - 2- SEAT BOLT WITH MAX OF [10 LB-FT] OF TORQUE.
 - 3- BACK BOLT OUT 1/2 TO 1 TURN.
 - 4- IF BOLT SEATS AND BACKS OUT FREELY WITHOUT SEIZURE, APPLY SPECIFIED ASSEMBLY TORQUE.
 - 5- IF BOLT DOES NOT SEAT WITH [10 LB-FT] TORQUE OR DOES NOT BACK OUT FREELY, HOLD ENTIRE ASSEMBLY FOR INSPECTION FOR CAUSE OF SEIZURE. DO NOT REPAIR UNTIL INSPECTION HAS BEEN COMPLETED.

- 2** WHILE WHEEL ROTATES ONE TURN MINIMUM, TORQUE SPINDLE NUT TO [80-200 LB-FT]. BACK-OFF UNTIL BEARINGS ARE LOOSE. RE-TORQUE SPINDLE NUT TO [20-144 LB.-IN].
- (1)- IF A COTTER PIN HOLE IN SPINDLE IS IN LINE WITH A SLOT IN NUT, BACK-OFF 1/2 REVOLUTION INSTALL COTTER PIN.
 - (2)- IF A COTTER PIN HOLE IN SPINDLE DOES NOT LINE UP WITH A SLOT IN NUT, BACK-OFF 1/2 REVOLUTION MINIMUM-1/8 REVOLUTION MAXIMUM, INSTALL COTTER PIN.
 - (3)- THIS ADJUSTMENT SHOULD GIVE .002 TO .006 HUB END PLAY ON SPINDLE.

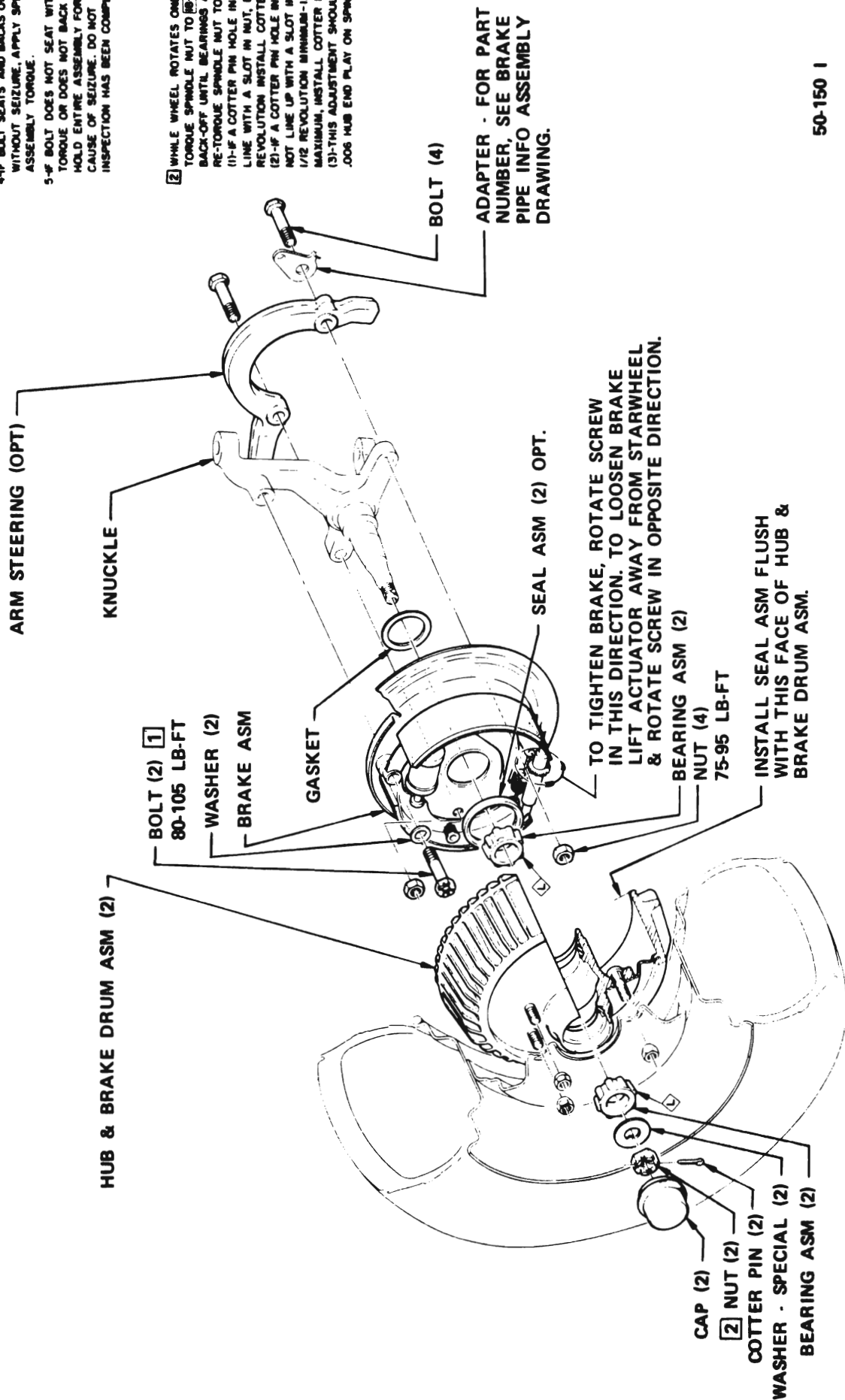

50-150 I

Figure 50-25 Front Brake and Wheel Installation - 4D-4F-4G-4H

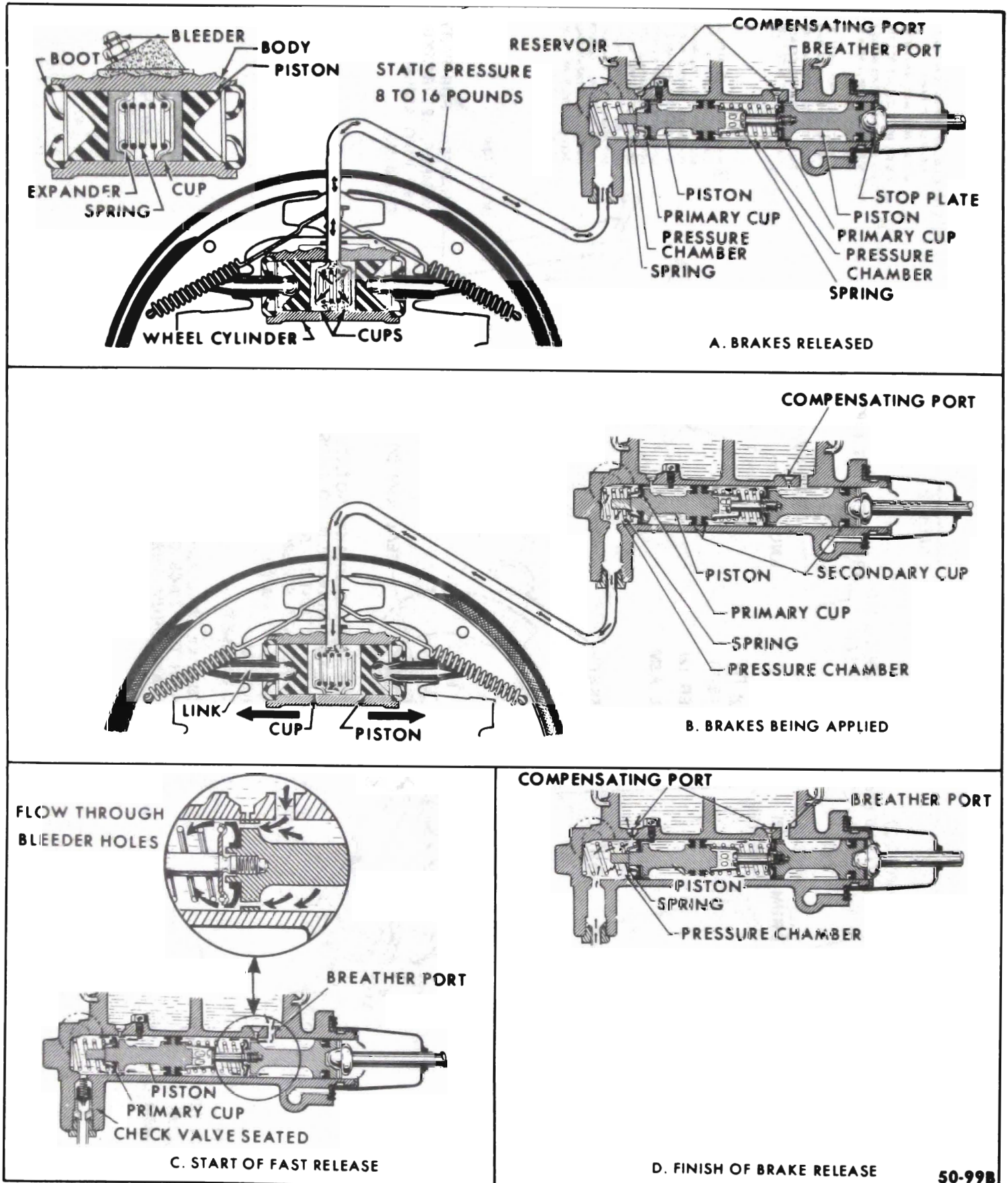

Figure 50-26 Operation of Brake Hydraulic System