

SECTION C**DELCO-MORAINÉ TANDEM POWER BRAKE UNIT****4L-4N-4R-4P-4U-4V-4Y SERIES****CONTENTS**

Division	Subject	Page No.
I.	TROUBLE DIAGNOSIS:	
	Tandem Power Brake Unit Trouble Diagnosis	50-50
II	DESCRIPTION AND OPERATION:	
	Description of Tandem Power Brake Unit	50-51
	Operation of Tandem Power Brake Unit	50-53
III	ADJUSTMENTS AND MINOR SERVICE: (Not Applicable)	
IV	REMOVAL AND INSTALLATION:	
	Removal and Installation of Tandem Power Brake Unit	50-57
V	OVERHAUL AND MAJOR SERVICE:	
	Disassembly of Tandem Power Brake Unit	50-57
	Cleaning and Inspecting Tandem Power Brake Unit	50-62
	Reassembly of Tandem Power Brake Unit	50-63
	Gauging of Tandem Power Brake Unit	50-68
VI	SPECIFICATIONS:	
	Tandem Power Brake Unit Specifications	50-68

DIVISION I**TROUBLE DIAGNOSIS**

50-26 TANDEM POWER BRAKE UNIT TROUBLE DIAGNOSIS

General Information

A. Testing

The same types of brake trouble are encountered with power brakes as with standard hydraulic brakes and disc brakes. Before checking the power brake system for the source of trouble, refer to the trouble diagnosis of standard brakes in Section A, Division IV. After these possible causes have been eliminated, check for the cause as outlined in the following charts:

Condition	Possible Cause	Correction
Hard Pedal	1. Broken or damaged hydraulic brake lines.	1. Inspect and replace as necessary.
	2. Vacuum failure.	2. Check for: Faulty vacuum check valve or grommet - replace. Collapsed or damaged vacuum hose - replace. Plugged or loose vacuum fitting - repair. Faulty air valve seal or support plate seal - replace. Damaged floating control valve - replace. Bad stud welds on front or rear housing or power head - replace, unless easily repaired.
	3. Defective diaphragm.	3. Replace
	4. Restricted air filter element.	4. Replace
	5. Worn or badly-distorted reaction disc (tandem diaphragm).	5. Replace reaction disc.
	6. Worn or distorted reaction plate or levers (single diaphragm).	6. Replace plate or levers.
	7. Cracked or broken power pistons or retainer.	7. Replace power pistons and piston rod retainer.
	8. Incorrect selective reaction piston (tandem diaphragm only).	8. Gauge reaction piston and replace with correct piston.
Grabby Brakes (Apparent Off-and-On Condition)	1. Broken or damaged hydraulic brake lines.	1. Inspect and replace as necessary.

DELCO-MORAINÉ TANDEM POWER BRAKE UNIT - 4L-4N-4R-4P-4U-4V-4Y SERIES 50-51

	2. Insufficient fluid in master cylinder.	2. Fill reservoirs with approved brake fluid; check for leaks.
	3. Defective master cylinder seals.	3. Repair or replace as necessary.
	4. Cracked master cylinder casting.	4. Replace
	5. Leaks at front disc brake calipers or rear wheel cylinders in pipes or connections.	5. Inspect and repair as necessary.
	6. Air in hydraulic system.	6. Bleed system.
Brakes Fail to Release	1. Blocked passage in power piston.	1. Inspect and repair or replace as necessary.
	2. Air valve sticking shut.	2. Check for proper lubrication of air valve "O" ring.
	3. Broken piston return spring.	3. Replace
	4. Broken air valve spring.	4. Replace
	5. Tight pedal linkage.	5. Repair or replace as necessary.

DIVISION II**DESCRIPTION AND OPERATION****50-27 DESCRIPTION OF TANDEM POWER BRAKE UNIT**

The Delco Moraine Tandem Power Brake Unit is composed of two major assemblies: The vacuum tandem power head and the hydraulic dual master cylinder. The dual master cylinder is similar to those used for previous years except for an increase in reservoir and displacement capacity.

The power heads include a 9-1/2" diameter rear housing (26) and an 8" diameter front housing (25). These housings are locked together by rotating the tangs on the edge of the front housing into slots in the edge of the rear housing. See Figure 50-68.

The power cylinder contains the power piston assembly and the power piston return spring (1). The power piston assembly is composed of three basic parts: a (plastic) primary power piston (4), a (plastic) secondary power piston (6), and a (steel) housing divider (5).

The primary power piston contains the valving

mechanism, which consists of the air valve and push rod assembly (7) and the floating control valve assembly (8). The air valve and push rod assembly is retained in the primary power head piston by a snap ring. The floating control valve assembly is held in place in the primary power piston by the floating control valve retainer (9). A push rod limiter washer (10), located immediately behind the floating control valve, is included to prevent the push rod from contracting the plastic tube of the primary power piston. The push rod ball end is staked to the air valve; the push rod eye end protrudes from the power head rear housing through a filter element (11), located behind the limiter washer, and a boot (12) containing a silencer (13).

The bead on the I.D. of the primary diaphragm (14) is held in a sealed position on the primary power head piston when the primary diaphragm support plate (15) is rotated into a locked position on the primary power piston.

The primary power piston bearing (3) is located in the center opening of the rear housing and provides a seal as well as a sliding surface for the tubular section of the primary power piston. A power head silencer (24) is positioned around the O.D. of the tubular section of the primary power piston.

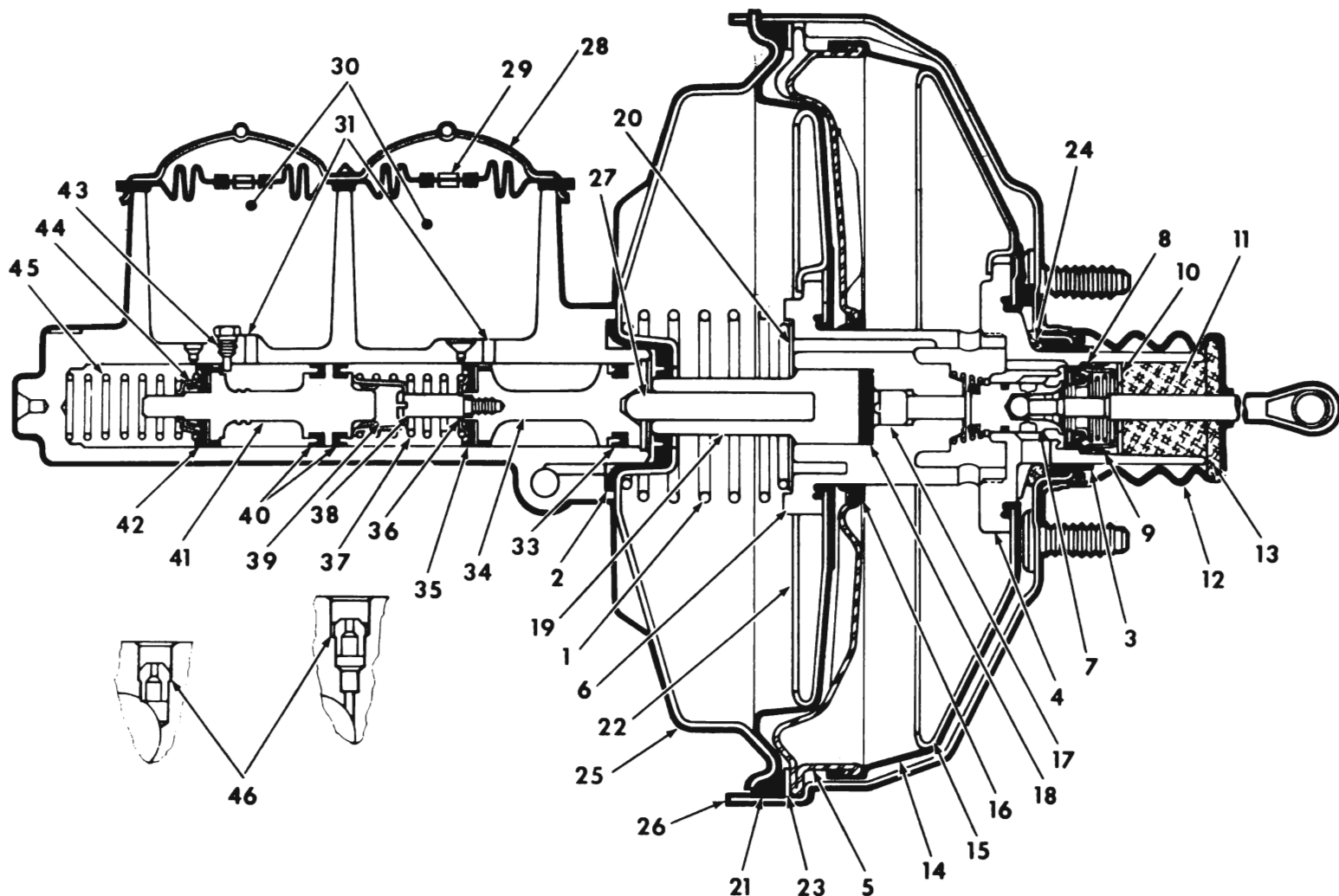

50-175

Figure 50-68 Tandem Power Brake Unit

The secondary power piston bearing (16) is positioned on the I.D. of the housing divider (5). The threaded end of the secondary power piston slides through the bearing in the housing divider and screws into the primary power piston.

The primary diaphragm is held in position on the O.D. of the housing divider by stretching the bead on the O.D. of the diaphragm and positioning it over the turned-up edge of the divider. When the front and rear housings are locked together, the housing divider is held in a stationary position between the housings.

The secondary power piston contains the reaction mechanism, which consists of the reaction piston (17), the rubber reaction disc (18) and the (plastic) piston rod retainer (19). The piston rod retainer houses the piston rod (27) which contacts the master cylinder primary piston. The piston rod retainer is held in place by a retainer plate (20) which is positioned on the "lug" end of the secondary power piston and held in place by the power piston return spring.

The bead on the I.D. of the secondary diaphragm (21) is held in a sealed position on the secondary power piston when the secondary diaphragm support plate

(22) is rotated to a locked position on the secondary power piston.

The bead on the O.D. of the secondary diaphragm is positioned between the diaphragm support ring (23) and the front housing. This bead creates a seal when the housings are rotated into a locked position.

A front housing seal (2) is located in the depression in the front housing. A vacuum check valve assembly is located in the front housing for connection to the vacuum source.

Two fluid reservoirs (30) are integrally cast with the master cylinder body and supply fluid to the spaces between the primary and secondary seals through the drilled compensating holes (31) in the casting.

Within the bore of the master cylinder is the primary piston assembly (34), which includes a secondary seal (33), primary seal (35), primary seal protector, spring retainer (36), primary piston spring (37), secondary piston stop (39), and piston extension screw (38). The secondary piston assembly (41) includes two secondary seals (40), a primary seal (42), primary seal protector, spring retainer (44), and secondary piston spring (45).

The reservoir diaphragm (29) and cover (28) provide protection from contamination of the brake fluid. A stop screw (43) is located in the bottom of the front fluid reservoir. The stop screw aids in assembly and prevents rearward movement of the secondary piston when pressure bleeding.

Connection is made to the front disc brake caliper pistons and rear wheel cylinders through the two hydraulic outlets (46).

50-28 OPERATION OF TANDEM POWER BRAKE UNIT

A line from a vacuum source on the engine is connected to the vacuum check valve in the front housing of the power brake. The check valve serves to prevent loss of vacuum in the power brake when the vacuum from the engine is low or not available.

A. Released Position (At Rest)

In the released position the air valve (7) is seated on the floating control valve (8) at Point (48) and prevents the floating control valve from seating on the primary power piston at Point (47). The floating

control valve assembly (8) is held against the air valve seat by the floating control valve spring (54). Air, under atmospheric pressure, which enters through the filter element (11) in the tubular section of the primary power piston (4) is thus shut off at point (48). See Figure 50-69.

At rest, the position of the power piston assembly is determined by the primary piston which is held against the rear housing. The air valve spring (53) holds the air valve (7) back, so that its retaining ring (59) rests against the primary power piston (4).

In the released position an equal amount of vacuum is present on both sides of both power pistons. Vacuum, which is present at all times in the spaces (51 and 52) to the left of each power piston, is now also present on the right side (areas 49 and 50) of each power piston.

With the power head in the released position, the primary seals (35 and 42) on the primary piston (34) and secondary piston (41) are held back past the two by-pass holes (55) in the bore of the master cylinder. In this position, no hydraulic pressure is present in the system.

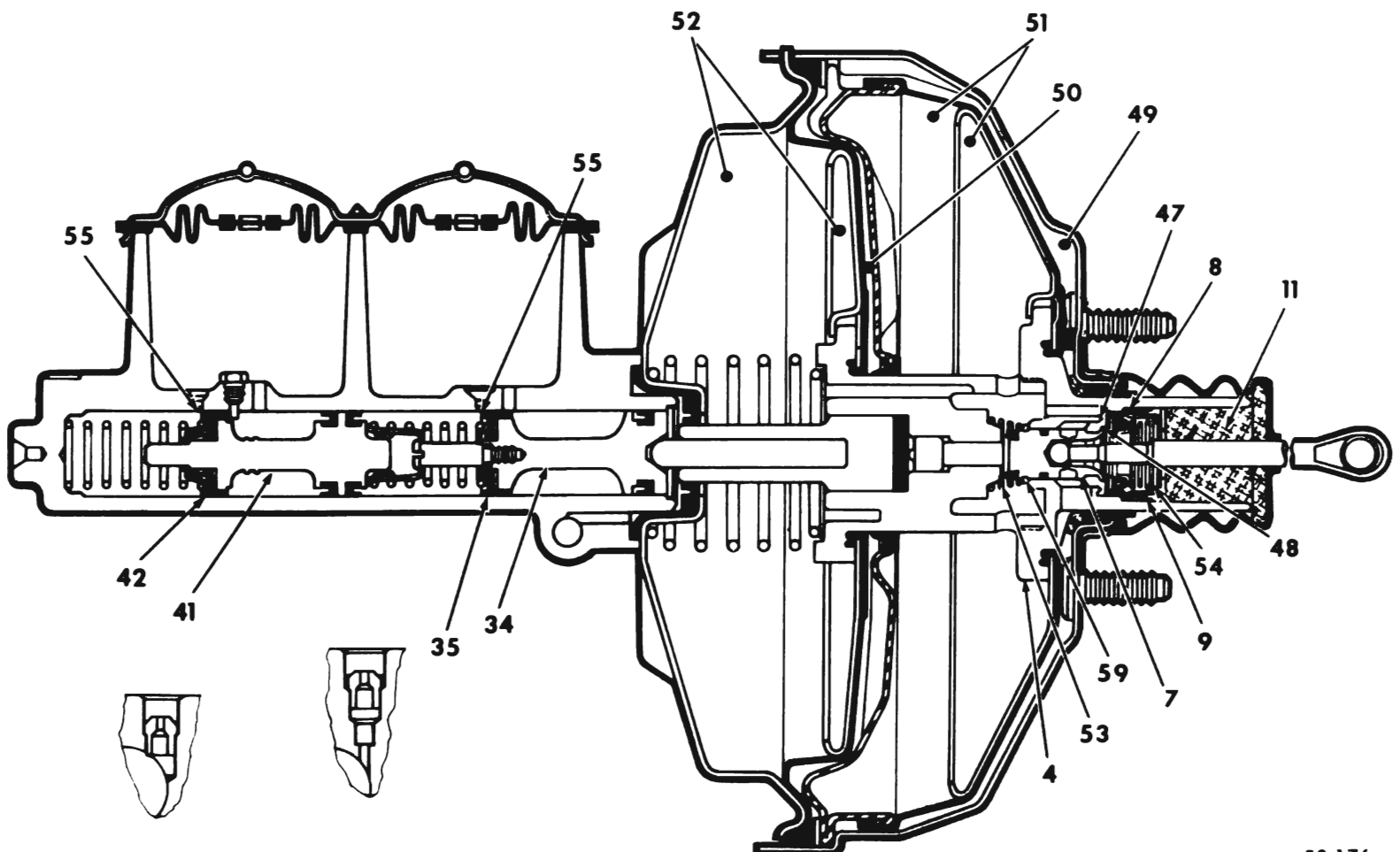

Figure 50-69 Released Position

B. Applying Position

As the brake pedal is depressed, the air valve push rod assembly (7) moves in the direction of the master cylinder. The floating control valve (8), being loaded by the spring immediately behind it, follows the air valve until it contacts and seats on the primary power piston at point (47). With the floating control valve seated on the primary power piston (4) at point (47), passage way (56) is closed and the vacuum source is shut off from the areas (49 and 50) behind both power pistons. As the air valve continues to move in the direction of the master cylinder it unseats from the floating control valve. See Figure 50-70.

When the air valve unseats from the floating control valve, passage (57) is opened to air at atmospheric pressure. Air at atmospheric pressure travels through holes in the boot, around the silencer (13), through the filter (11), through the center of the floating control valve (8), and through the open passage (57) into areas (49 and 50).

In this position only areas (51 and 52) are still connected to the vacuum source. The differential in pressure between the areas (49 and 50) with air at atmospheric pressure and the areas (51 and 52)

connected to the vacuum source, forces the power pistons (4 and 6) to travel toward the master cylinder.

As the power pistons (4 and 6) travel in the direction of the master cylinder, the piston rod (27) forces the master cylinder primary piston (34) into the bore of the master cylinder. The primary piston spring (37) forces the master cylinder secondary piston (41) to move forward. As the primary seals (35 and 42) on both master cylinder pistons pass the by-pass holes (55) in the bore, hydraulic pressure begins to build up in the lines to the front disc brakes and rear drum brakes.

As pressure builds up ahead of the master cylinder primary piston (34), an equal force is also created in the direction of the brake pedal. This reaction force on the end of the piston rod (27) is transmitted through the piston rod retainer (19). The piston rod retainer compresses the rubber reaction disc (18) and causes the reaction disc to exert a portion of the reaction force against the reaction piston (17). This results in a movement of the reaction piston toward the air valve. The air valve and the reaction piston contact each other to transmit this reaction force through the push rod to the brake pedal.

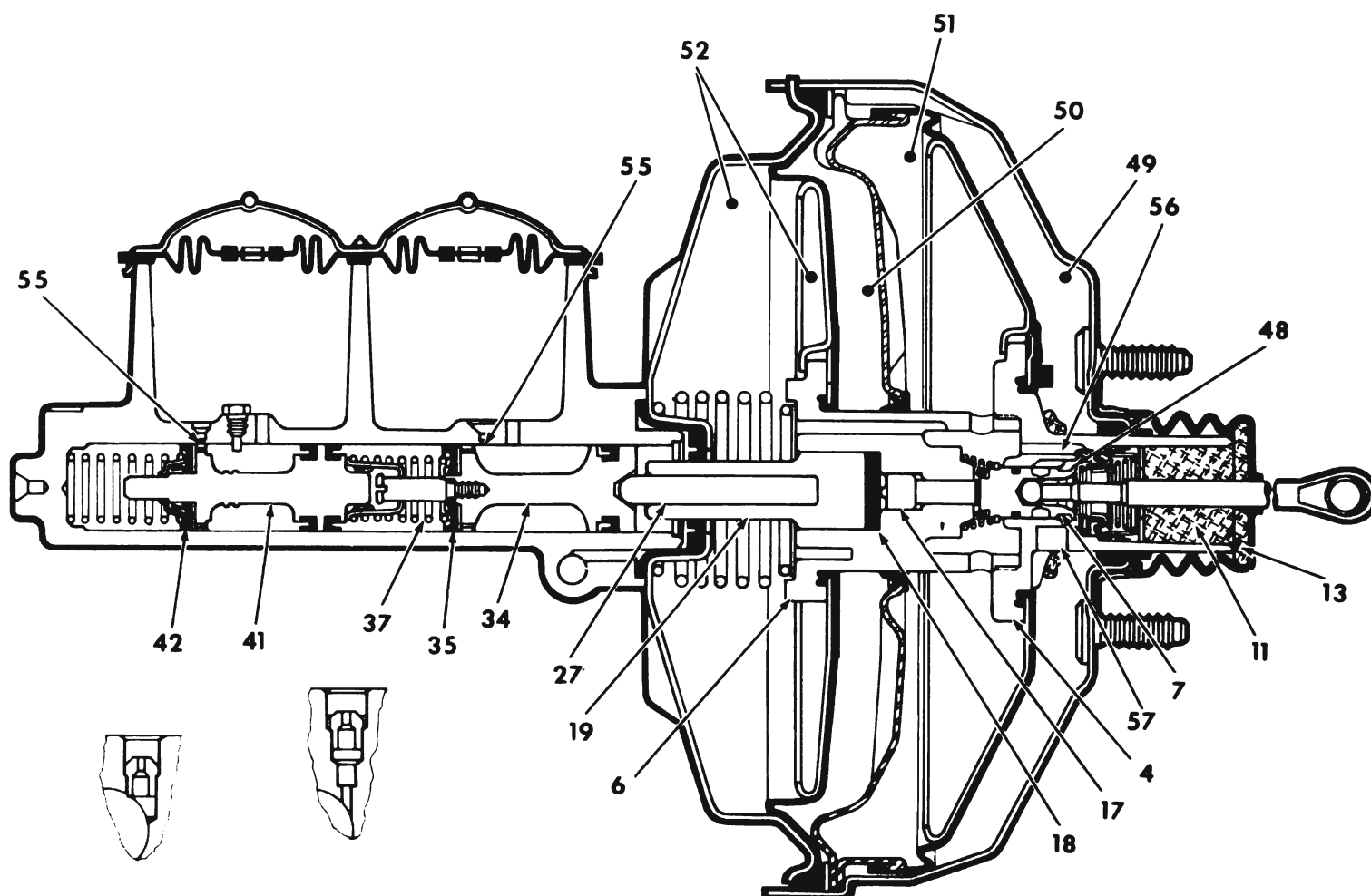
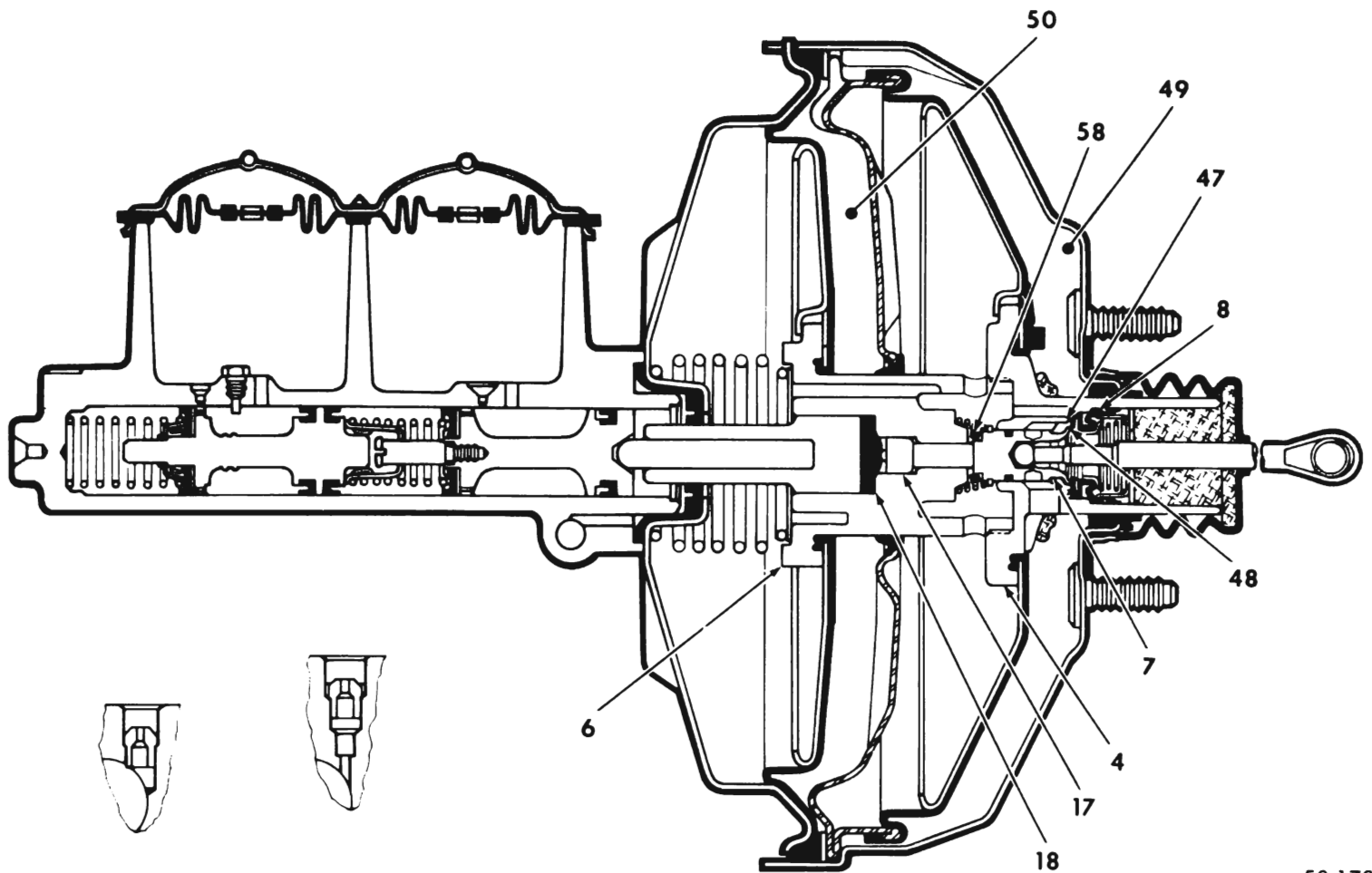

Figure 50-70 Applying Position



50-178

Figure 50-71 Holding Position

C. Holding Position

When the desired braking is reached and no additional pressure is applied to the brake pedal, the power brake will go into the holding or poised position. See Figure 50-71.

The power pistons (4 and 6) travel toward the master cylinder only far enough to bring the floating control valve (8) into contact with the air valve assembly (7). At this point the floating control valve is seated on the primary power piston (4) at point (47) and on the air valve assembly at point (48). The seating of the floating control valve on the air valve shuts off the flow of atmospheric air to areas (49 and 50). Since the floating control valve has maintained its seated position on the power piston, areas (49 and 50) are still not open to the vacuum source.

In the hold position, the rubber reaction disc (18) is compressed and extrudes into the cavity in the area of the reaction piston (17), and the reaction piston and end of the air valve are now in full contact.

The reaction force and the apply force at the push rod are now balanced; the relative position of the power pistons, valving, and reaction mechanism will be maintained until either more pressure is applied to the brake pedal or the brake pedal is released.

Figure 50-71 illustrates a reaction bumper (58). This bumper is provided for noise control and will contact the secondary power piston only during brake applications that utilize the total available power brake assist.

D. Releasing Position

As the pressure at the brake pedal is released, the air valve spring (53) forces the air valve assembly (7) back until its retaining ring (59) rests against the primary power piston (4). The contact of the air valve assembly with the floating control valve has shut off the flow of atmospheric pressure air to areas (49 and 50). As the air valve spring forces the air valve assembly into its released position, the air valve lifts the floating control valve (8) from its seat (47) on the primary power piston. The air valve (7) seating on the floating control valve (8) at point (48) has shut off the outside air source. The unseating of the floating control valve from the power piston opens areas (49 and 50) to the vacuum source through passage way (56). See Figure 50-72.

Vacuum, which is present at all times in the spaces to the left of each power piston is now also present on the

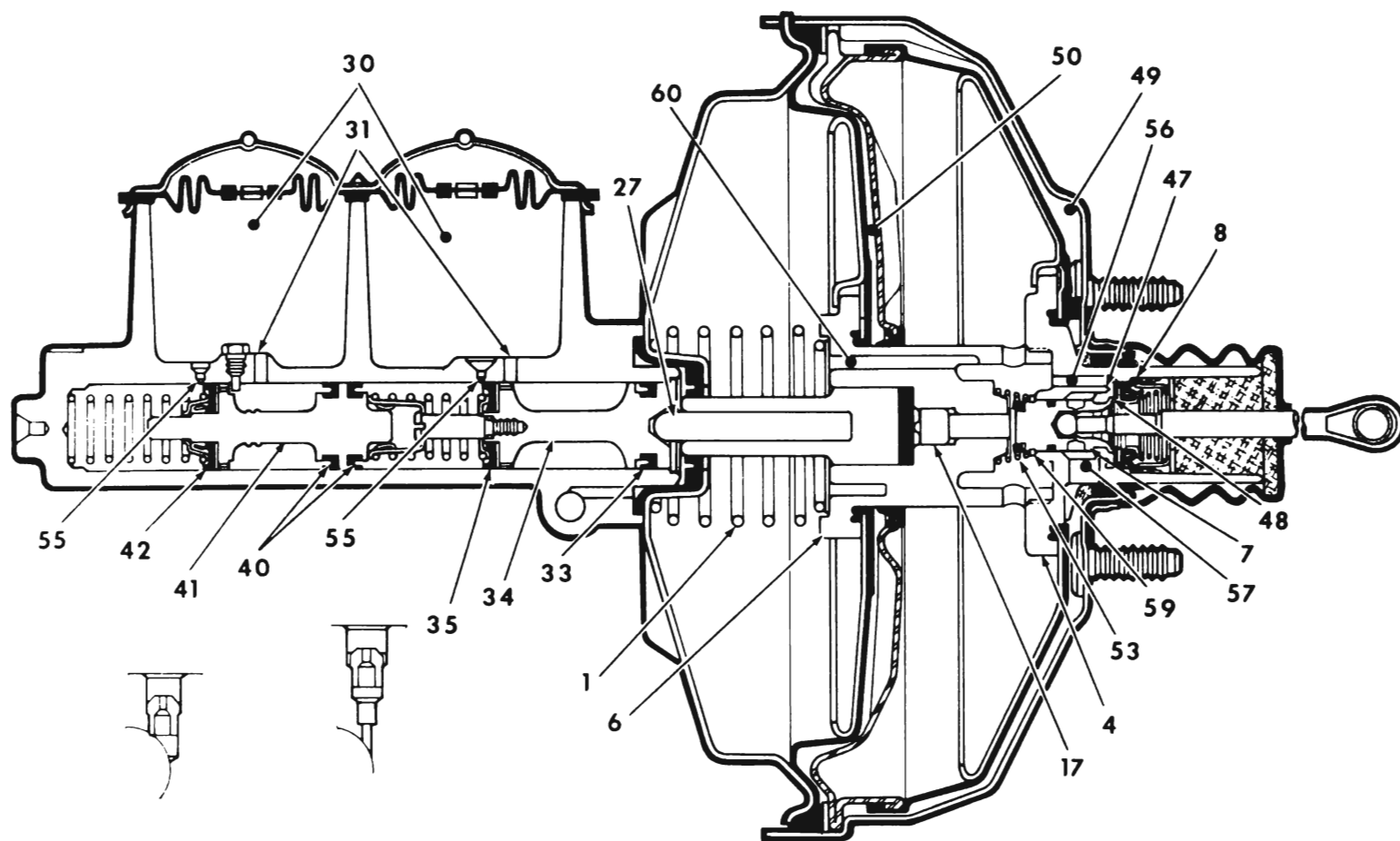

50-179

Figure 50-72 Releasing Position

right side (areas 49 and 50) of each power piston. Air in spaces (49 and 50) is drawn through two small passages (57) in the primary power piston, over the valve seat in the primary power piston, through two passages (56) in the primary power piston, through two passages (60) in the secondary power piston, and into the space at the left of the secondary power piston. It is then drawn through the check valve and to the vacuum source.

Now that both sides of both power pistons are exposed to equal vacuum, the power piston return spring (1) will return the power pistons (4 and 6) to the released or at rest position. As the primary power piston is returned to its released position against the rear housing, the master cylinder pistons (34 and 41) and their primary cups (35 and 42) return back past the by-pass holes so that brake fluid from the front disc brake calipers and rear wheel cylinders flows back into the master cylinder, reducing the hydraulic pressure in the brake system.

If the brake pedal is released quickly, the master cylinder pistons (34 and 41) immediately return to the released position. When the fluid in the lines cannot return as quickly as the pistons, a low pressure area is created in front of both primary cups. This low pressure area is compensated for by the flow of fluid from the reservoir through the compensating holes (31) to the space between the primary cups (35 and 42)

and secondary seals (33 and 40) and through the holes in the pistons (34 and 41). The excess fluid introduced into the system during compensation will return to the fluid reservoirs (30 through the small by-pass holes (55) in the master cylinder bore.

E. Vacuum Source Failure

In case of vacuum source interruption, enough vacuum is available in the power brake to make about three power assisted stops.

If the vacuum check valve should fail or if the vacuum stored in the unit is exhausted, it is still possible to operate the power brake by purely mechanical effort.

As pressure is applied to the brake pedal, the end of the air valve assembly (7) travels toward the master cylinder and contacts the reaction piston (17) and the secondary power piston (6) and forces both power pistons (4 and 6) to move forward. The master cylinder piston rod (27) forces the primary and secondary master cylinder pistons (34 and 41) and their primary cups (35 and 42) past the by-pass holes (55) in the bore and hydraulic pressure is built up in the system.

The pedal effort required for a manual application, such as described, is considerably greater than with vacuum assist.

DIVISION IV

REMOVAL AND INSTALLATION

50-29 REMOVAL AND INSTALLATION OF TANDEM POWER BRAKE UNIT

1. Disconnect the brake lines from the two master cylinder hydraulic outlets. Cover brake line fittings to prevent dust and dirt from entering brake lines.
2. Disconnect the vacuum hose from the vacuum check valve on the front housing of the power head. Plug vacuum hose to prevent dust and dirt from entering hose.
3. Disconnect the power brake push rod from the brake pedal.
4. Remove the four nuts from the mounting studs which hold the power brake to the cowl.
5. Carry the power brake to a clean work area and clean the exterior of the power brake prior to disassembly.

CAUTION: *Fasteners in the following steps are important attaching parts in that they could affect the performance of vital components and systems and/or could result in major repair expense. It must be replaced with one of the same part number, or with an equivalent part, if replacement becomes necessary. Do not use a replacement part of lesser quality or substitute design. Torque values must be used as specified during reassembly to assure proper retention of this part.*

6. Mount power brake assembly to cowl.
7. Remove inboard locknut from front housing stud, attach metering valve mounting bracket, reassemble locknut on stud and torque to 25 foot pounds.
8. Connect power brake push rod to brake pedal.
9. Connect vacuum hose to vacuum check valve.
10. Connect brake lines to master cylinder hydraulic outlets.
11. Bleed brakes as necessary and fill fluid reservoirs to within 1/4" (plus or minus 1/8") from the lowest portion of the top of each reservoir.

DIVISION V

OVERHAUL AND MAJOR SERVICE

50-30 DISASSEMBLY OF TANDEM POWER BRAKE UNIT

A. Disassembly of Overall Unit

Scribe a mark on the top center of the front and rear housings in line with master cylinder reservoir cover to facilitate reassembly.

1. Remove master cylinder reservoir cover bails, reservoir cover and diaphragm, and empty brake fluid from reservoirs. Pump push rod to remove fluid from master cylinder bore. See Figure 50-73.
2. Remove two lock nuts which hold master cylinder to front housing and remove master cylinder.
3. Mount Unlock Tool J-23456 in a vise. Position housing assembly on tool so that four studs fit in holes provided. See Figure 50-74.
4. Position handle over two studs with tubular projections downward. Rotate screw to apply downward pressure to handle, then rotate front housing counterclockwise to unlock housings. It is normal for this operation to require heavy pressure to unlock housings.
5. Rotate screw to release spring tension and remove front housing group.

B. Disassembly of Front Housing Group

1. Remove the power piston return spring. The retainer plate may come out with the power piston return spring. Remove the vacuum check valve and grommet from the front housing, if the check valve is defective or the grommet cracked, cut or damaged.

C. Disassembly of Rear Housing Group

1. Remove the boot and boot retainer from the rear housing and push rod. Remove the felt silencer from inside the boot.

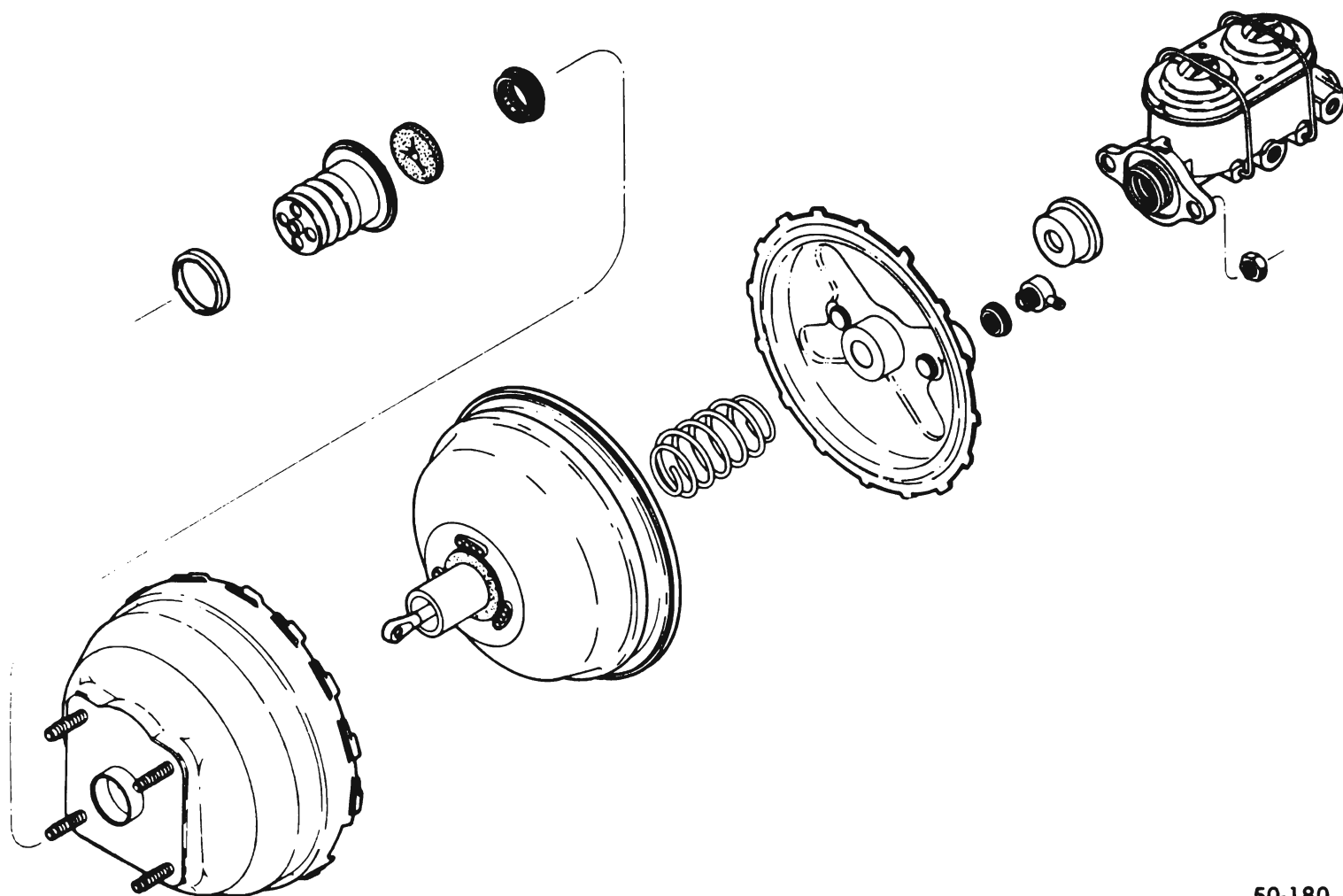

50-180

Figure 50-73 Exploded View of Major Assemblies

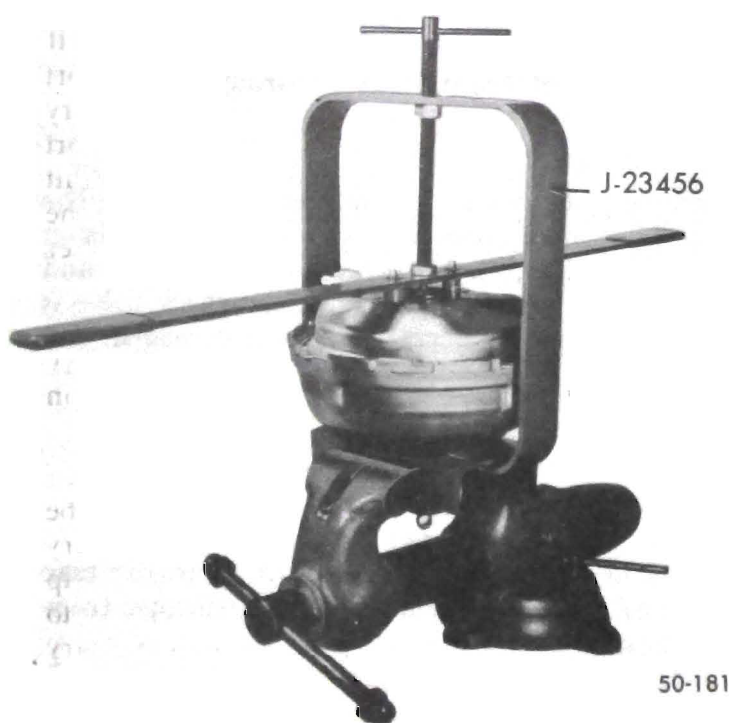

50-181

Figure 50-74 Unlocking Front and Rear Housings

2. Remove the power piston group from the rear housing and remove the primary power piston bearing from the center opening of the rear housing.

D. Disassembly of Power Piston Group

1. Lift the bead on the O.D. of the secondary diaphragm and remove the diaphragm support ring. See Figure 50-75.
2. If not already disengaged, remove the retainer plate from the secondary piston. Remove the piston rod retainer and piston rod from the secondary piston.
3. Mount double-ended tool J-23101 (*with large diameter end up*) in a vise. Position the secondary power piston so that the two radial slots in the piston fit over the ears (tang) of the tool. See Figure 50-76.

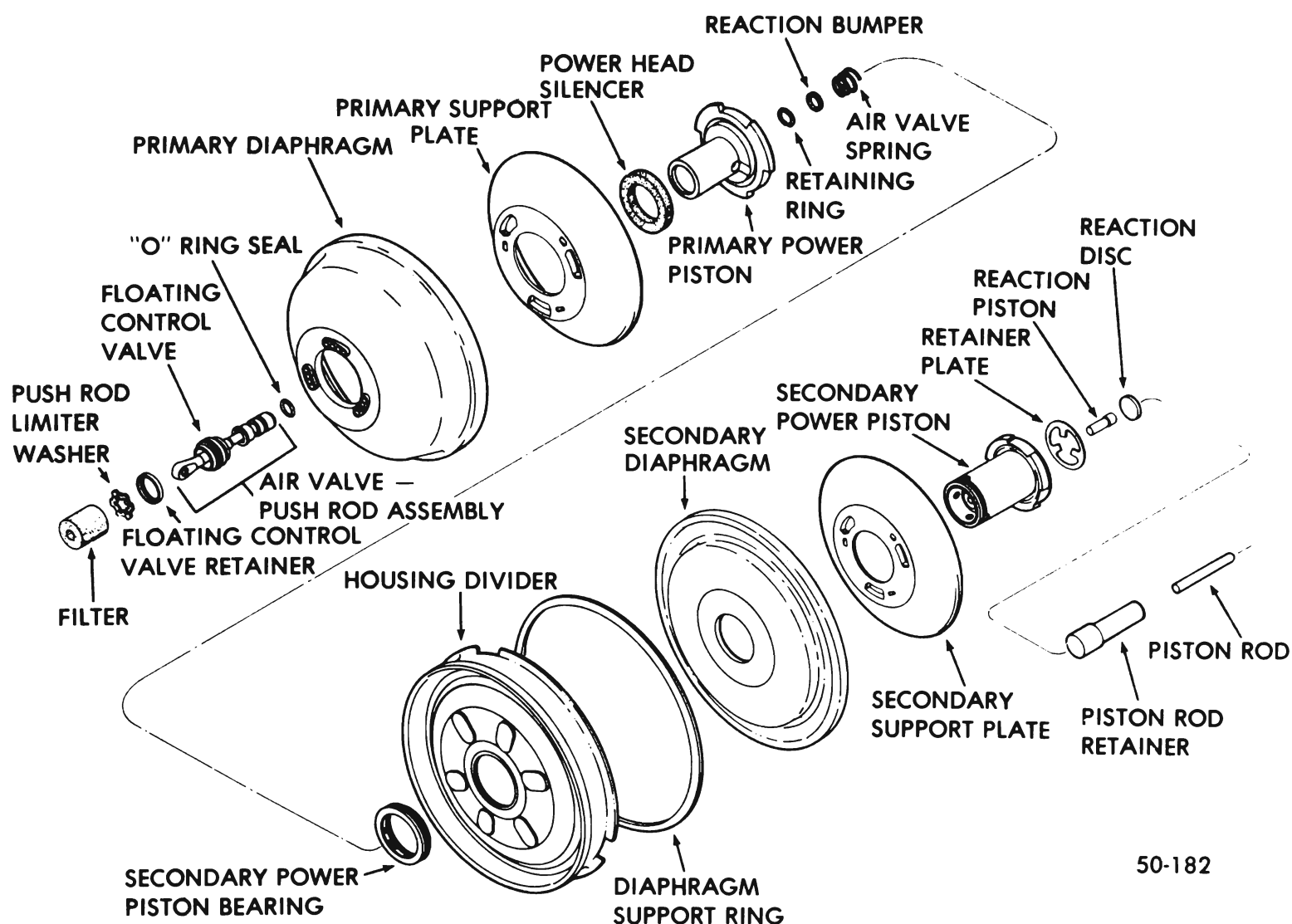

50-182

Figure 50-75 Power Piston Group

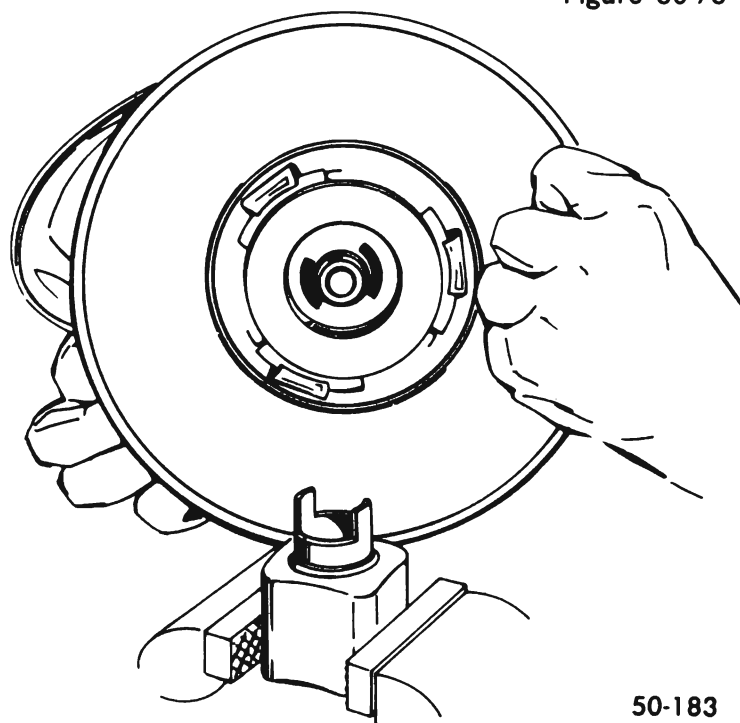

50-183

Figure 50-76 Positioning Secondary Power Piston In Tool J-23101 (Large Dia. End Up) Mounted In Vise

4. Fold back primary diaphragm from the O.D. of the primary support plate. Grip the edge of the support plate and rotate counterclockwise to unscrew the

primary power piston from the secondary power piston. Note: It is possible that the primary support plate will unlock from the primary piston before the primary piston unscrews from the secondary piston. If this happens, continue to turn the primary support plate counterclockwise. Tabs ("stops") on the primary support plate will temporarily lock the primary support plate to the primary power piston and permit continued counterclockwise rotation to unscrew the primary power piston from the secondary power piston. See Figure 50-77.

5. Remove the housing divider from the secondary power piston. Remove the secondary power piston bearing from the housing divider.

6. The secondary power piston should still be positioned on tool J-23101. Fold back secondary diaphragm from O.D. of secondary support plate. Grip the edges of the support plate and rotate clockwise to unlock the secondary support plate from the secondary power piston. See Figure 50-78.

7. Remove the secondary diaphragm from the secondary support plate.

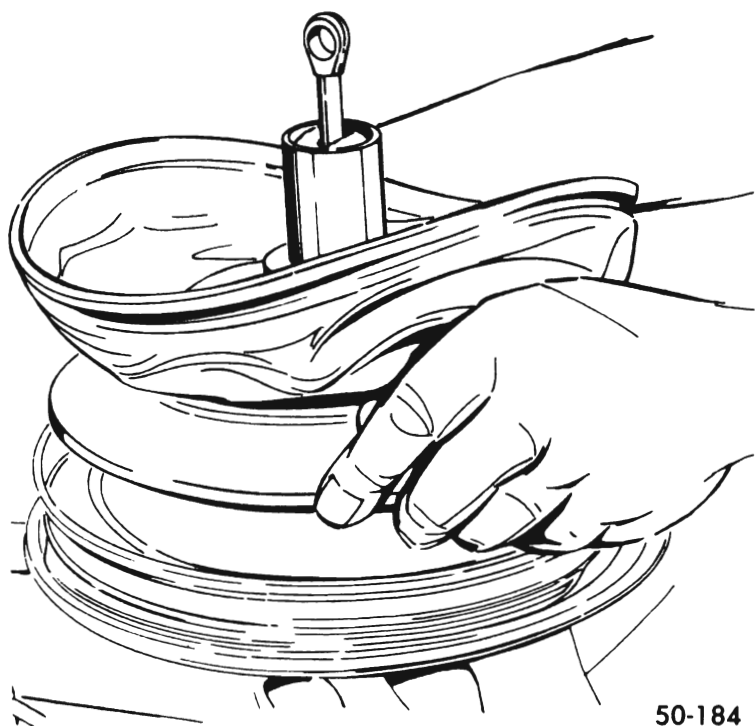

50-184

Figure 50-77 Locking or Unlocking Primary and Secondary Power Pistons

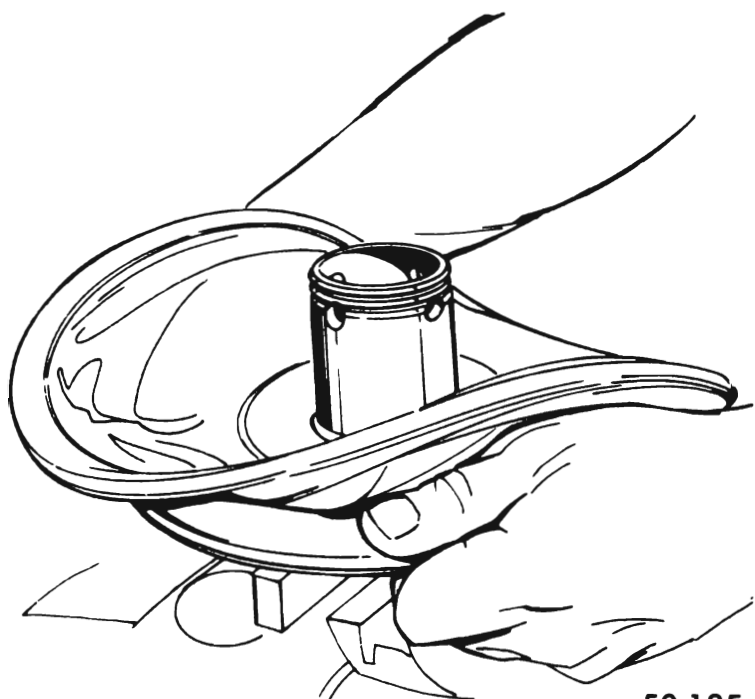

50-185

Figure 50-78 Locking or Unlocking Secondary Support Plate and Secondary Power Piston

8. Remove the reaction piston and reaction disc from the center of the secondary power piston by pushing down on the end of the reaction piston with a small object, such as a pencil, wooden dowel, or metal rod. See Figure 50-79.

9. Remove the air valve spring from the end of the air valve (if it didn't come off during disassembly of the power piston).

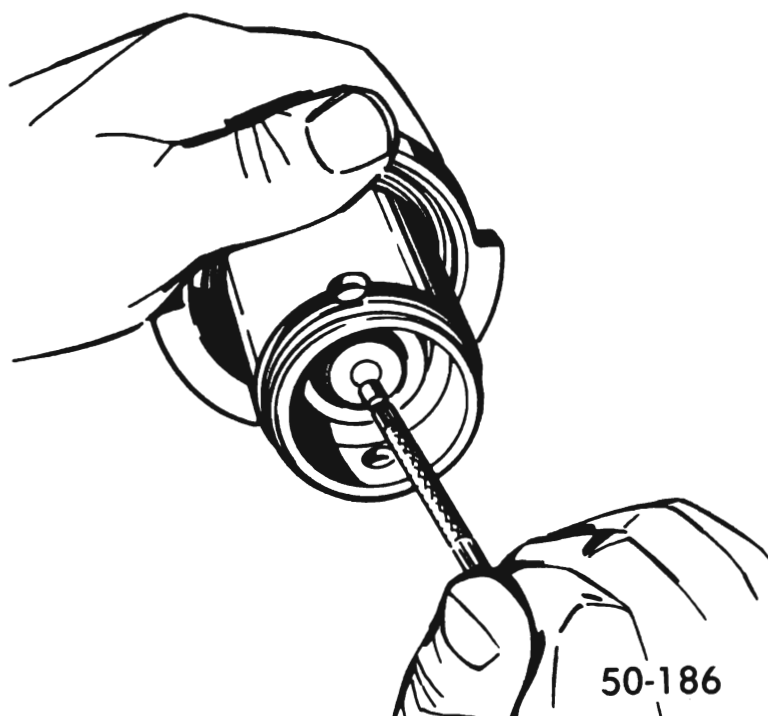

50-186

Figure 50-79 Removing Reaction Piston and Reaction Disc From Secondary Power Piston

10. Mount tool J-23101 in a vise (with *small diameter end up*). Position the primary power piston so that the two radial slots in the piston fit over the ears (tang) of the tool. See Figure 50-80.

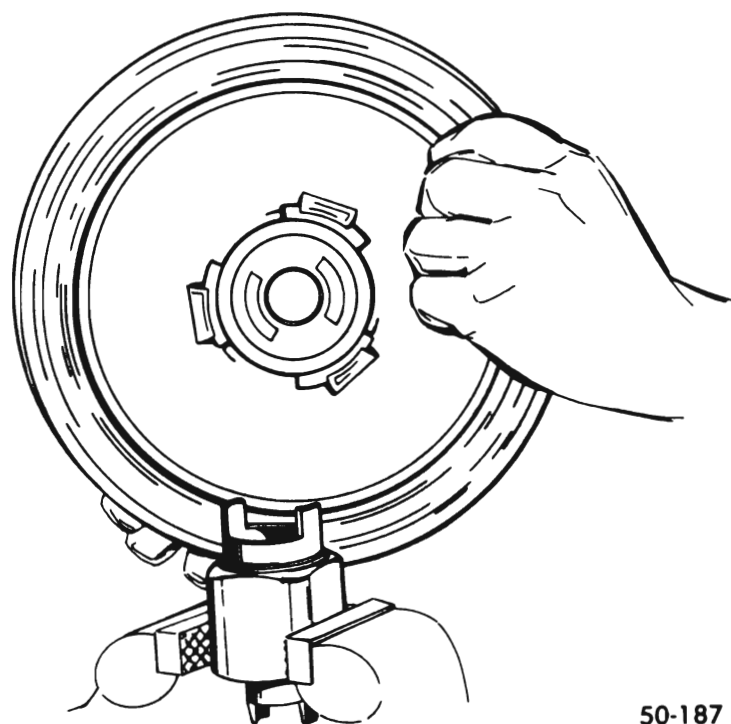

50-187

Figure 50-80 Positioning Primary Power Piston In Tool J-23101 (Small Dia. End Up) Mounted In Vise

11. Fold back primary diaphragm from the support plate. Grip the edge of the support plate and rotate in a counterclockwise direction to unlock the primary support plate from the primary power piston. See Figure 50-81.

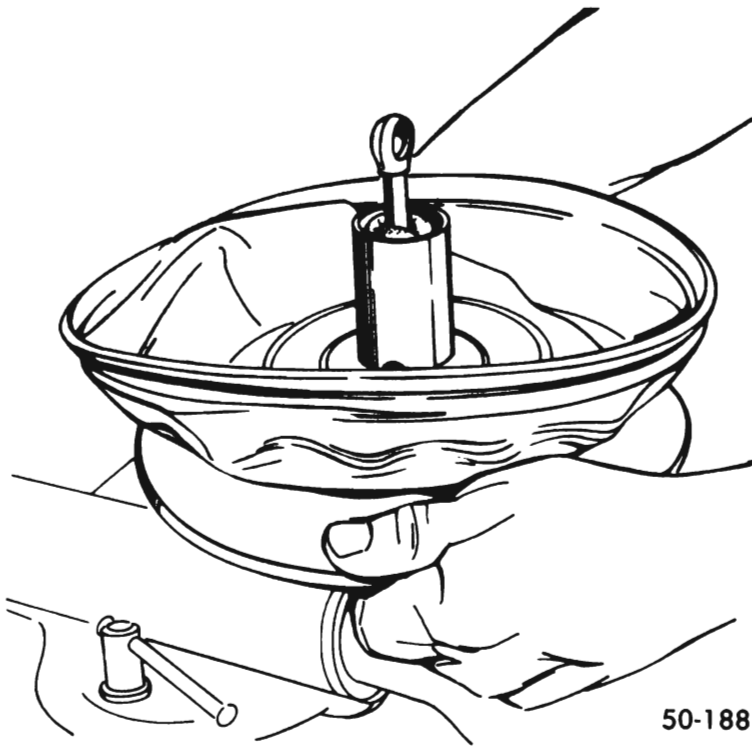

50-188

Figure 50-81 Locking or Unlocking Primary Support Plate From Primary Power Piston



50-189

Figure 50-82 Removing Retaining Ring From Air Valve

12. Remove the primary diaphragm from the primary support plate.

13. Remove the air filter and push rod limiter washer from the tubular section of the primary power piston.

14. Remove the power head silencer from the neck of the power piston tube.

15. Remove the rubber reaction bumper from the end of the air valve.

16. Using Truarc No. 2 pliers (J-4880), remove the retaining ring from the air valve. See Figure 50-82,

17. Remove the air valve-push rod assembly from the tube end of the primary power piston. The following removal methods are recommended:

(a) Place the primary power piston in an arbor press, and press the air valve push rod assembly out the bottom of the power piston tube with a rod not exceeding 1/2" in diameter.

(b) An alternate method would be the use of a heavy, round shanked screwdriver. Insert screwdriver on both sides of the push rod, and pull the air valve push rod assembly straight out. A considerable force will be required.

(c) Another method requires the use of Truarc No. 22 pliers. Approximately 5/8" from the pointed ends of

the pliers, file or saw a small slot (approximately 1/32" - 1/16" wide and 1/10" deep) on each half of the pliers. Round off the pointed ends of the pliers. Slip the slots in the pliers into tangs on the control valve spring retainer. Grip the pliers and pull the air valve push rod assembly straight out.

18. Removal of the air valve push rod assembly will disassemble the control valve retainer.

19. Remove the "O" ring seal from the air valve.

20. Models using air valve push rod assemblies with a formed eye on the end of the push rod will be serviced using a complete assembly, since the floating control valve cannot be removed over the eye end of the push rod.

E. Disassembly of Master Cylinder

1. Remove the small secondary piston stop screw from the bottom of the front fluid reservoir of the master cylinder. See Figure 50-83.

2. Place the master cylinder in the vise so that the lock ring can be removed from the small groove in the I.D. of the bore. Remove the lock ring and primary piston assembly. Remove the secondary piston, secondary piston spring and retainer by blowing air through the stop screw hole. If air is not available, a piece of wire may be used. Bend approximately 1/4" of one end of the wire into a right angle. Hook this end under the edge of the secondary piston and pull the secondary piston from the bore.

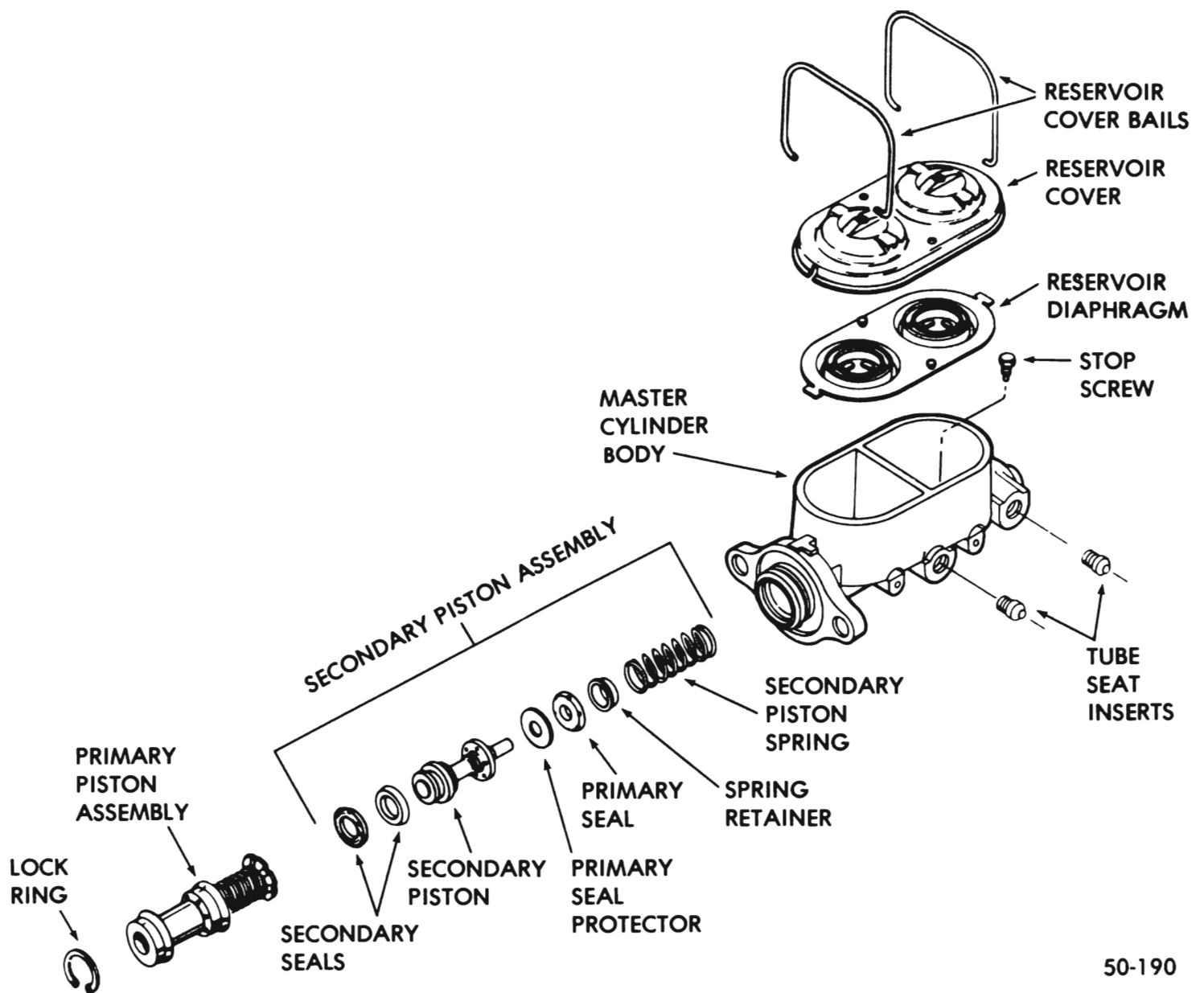

Figure 50-83 Exploded View of Typical Dual Master Cylinder

3. To replace a defective insert, the following procedure should be practiced:

(a) Place the master cylinder in a vise, so that the outlet holes are up. Enlarge the outlet holes in the tube seats using a $13/64$ " drill. Tap a $1/4$ " - 20 thread in these holes. Place a heavy washer over the outlet on the master cylinder and thread a $1/4$ " - 20 x $3/4$ " hex head bolt into the tube seat. Tighten the bolt until the tube seat is unseated.

(b) A more preferable way to remove a defective insert involves use of a self-tapping screw and a claw hammer. With a box-end or socket wrench, thread a No. 6 - 32 x $5/8$ " long self-tapping screw into the tube-fitting insert. Using the claw end of the hammer, remove the screw and insert.

4. Remove the casting from the vise and inspect the bore for corrosion, pits and foreign matter. Be sure the outlet ports are clean. Inspect the fluid reservoirs for foreign matter. Check the bypass and compensating

ports to the master cylinder bore to determine if they are unrestricted.

5. Remove the primary seal, primary seal protector and secondary seals from the secondary piston.

50-31 CLEANING AND INSPECTION OF TANDEM POWER BRAKE UNIT

A. Cleaning

Use Declene or clean brake fluid to thoroughly clean all reusable brake parts. Immerse in the cleaning fluid and brush metal parts with hair brush to remove foreign matter. Blow out all passages, orifices and valve holes. Air dry and place cleaned parts on clean paper or lint free clean cloth. If slight rust is found inside either the front or rear half housing assemblies,

polish clean with crocus cloth or fine emery paper, washing clean afterwards. Dirt is the major cause of trouble and wear in service. Be sure to keep parts clean until re-assembly. Re-wash at re-assembly if there is any occasion to doubt cleanliness--such as parts dropped or left exposed for eight hours or longer.

CAUTION: *If there is any suspicion of contamination or any evidence of corrosion, completely flush the car hydraulic brake system. Failure to clean the hydraulic brake system can result in early repetition of trouble. Use of gasoline, kerosene, anti-freeze, alcohol or any other cleaner, with even a trace of mineral oil, will damage rubber parts.*

B. Inspecting Rubber Parts

Wipe fluid from the rubber parts and carefully inspect each rubber part for cuts, nicks, or other damage. These parts are the key to the control of fluid or air flow. If the unit is in for overhaul, or if there is any question as to the serviceability of rubber parts, **REPLACE** them!

C. Inspecting Metal Parts

Inspect in accordance with Figures 50-90 and 91. The table is organized by power brake unit groups. **BADLY DAMAGED ITEMS, OR THOSE WHICH WOULD TAKE EXTENSIVE WORK OR TIME TO REPAIR, SHOULD BE REPLACED.** In case of doubt, install new parts. Do not rely on the brake unit being overhauled at an early or proper interval. New parts will provide more satisfactory service, even if the brake unit is allowed to go beyond the desired overhaul period.

50-32 REASSEMBLY OF TANDEM POWER BRAKE UNIT

A. General

1. Be careful during the rebuild procedure that no grease or mineral oil comes in contact with the rubber parts of the power brake unit.
2. Lubricate power head parts, as outlined below, with Delco Moraine power brake silicone lubricant. This lubricant is provided in the service repair kit. Clean brake fluid may be used as a lubricant for rubber parts in the master cylinder group.

B. Reassembly of Master Cylinder Group

1. If the brass tube inserts were removed, place the master cylinder in a vise so that the outlet holes are up.

Position the new brass tube inserts in the outlet holes, making sure they are not cocked. The recommended method of seating these inserts is to thread a spare brake line tube nut into each outlet hole and turn the nuts down until the insert bottoms. (*Remove the tube nut and check the outlet hole for loose brass burrs, which might have been turned up when the insert was pressed into position.*)

2. Each vehicle application of these cylinders is designed to produce the correct displacement of fluid from both the front and rear chambers under normal, failed and partially failed conditions. Delco Moraine dual cylinders are designed so that this variable displacement requirement is controlled within each bore size by the dimensions A and C on the secondary piston. See Figure 50-84.

3. Because the pistons vary in length, it is necessary to match them with identification rings, as shown on Figure 50-84. The wrong piston might operate satisfactorily under normal conditions but might fail under conditions of partial failure. Therefore, it is necessary that when replacing either complete master cylinder assemblies or the component pistons of these assemblies, it is imperative that the exact replacements be used.

4. Place new secondary seals in the two grooves in the flat end of the secondary piston assembly. The seal which is nearest the flat end will have its lips facing toward this flat end. The seal in the second groove should have its lips facing toward the end of the secondary piston which contains the small compensating holes.

5. Assemble a new primary seal and primary seal protector over the end of the secondary piston opposite the secondary seals, so that the flat side of the seal seats against the flange of the piston which contains the small compensating holes.

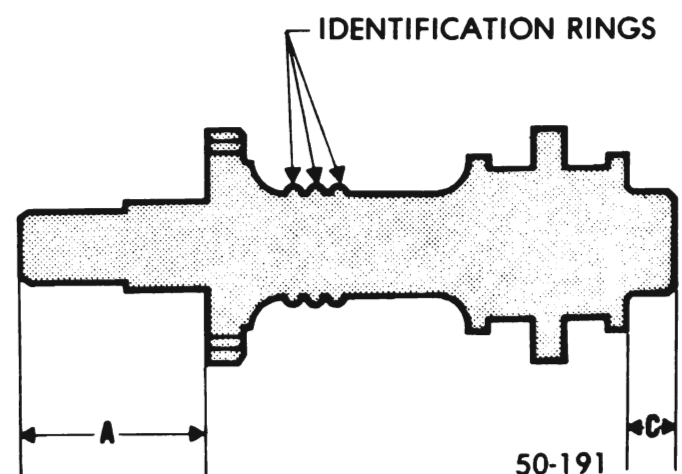

Figure 50-84 Secondary Piston

6. In order to insure correct assembly of the primary piston assembly, a complete primary piston assembly is included in the repair kits.

7. Coat the bore of the master cylinder with clean brake fluid. Coat the primary and secondary seals on the secondary piston with clean brake fluid. Insert the secondary piston spring retainer into the secondary piston spring. Place the retainer and spring down over the end of the secondary piston so that the retainer locates inside the lips of the primary seal.

8. Holding the master cylinder with the open end of the bore up or down, push the secondary piston into the bore so that the spring will seat in against the closed end of the bore. Use a small wooden rod to push the secondary piston to seat.

9. Place the master cylinder in a vise with the open end of the bore up. Coat the primary and secondary seals on the primary piston with clean brake fluid. Push the primary piston, secondary piston stop first, into the bore of the master cylinder. Hold the piston down and snap the lock ring into position in the small groove in the I.D. of the bore.

10. Continue to hold the primary piston down. This will also move the secondary piston forward and will insure that the secondary piston will be forward far enough to clear the stop screw hole, which is in the bottom of the front fluid reservoir. The stop screw is now positioned in its hole and tightened to a torque of 25-40 pound inches.

11. Install a new reservoir diaphragm in the reservoir cover and install the cover on the master cylinder. Assemble the bail wires into position to retain the reservoir cover.

C. Reassembly of Front Housing Group

1. If the grommet was removed for replacement, insert the new grommet in the front housing.

2. Press the vacuum check valve through the grommet.

D. Reassembly of Power Piston Group

1. Lubricate the I.D. and O.D. of the "O" ring seal with silicone lubricant and place on the air valve.

2. Wipe a thin film of silicone lubricant on the large and small O.D. of the floating control valve.

3. If the floating control valve needs replacement, it will be necessary to replace the complete air valve push rod assembly, since the floating control valve is a component part of this assembly and cannot be disassembled from the push rod.

4. Place the air valve end of the air valve push rod assembly into the tube of the primary power piston. Manually press the air valve push rod assembly so that the floating control valve bottoms on the tube section of the primary power piston. Installer tool J-23175 can be used to manually press the floating control valve to its seat.

5. Place the I.D. of the floating control valve retainer on the O.D. of floating control valve retainer installer J-23175. See Figure 50-85. Place over the push rod so that the closed side of the retainer seats on the floating control valve. With Installer J 23175, manually press the retainer and floating control valve assembly to seat in the primary power piston tube. See Figure 50-86.

6. After the floating control valve is seated, place the push rod limiter washer over the push rod and position on the floating control valve.

7. The filter element can now be stretched over the push rod eye and pressed into the primary power piston tube.

8. Using Truarc No. 2 plier (J-4880), place the retaining ring into the groove in the air valve. See Figure 50-82.

9. Position the rubber reaction bumper on the end of the air valve.

10. *Tolerances of those component parts affecting output of the tandem power brake are very critical*. In order to maintain correct power brake output, the power piston assembly must be gaged for selective fit of reaction

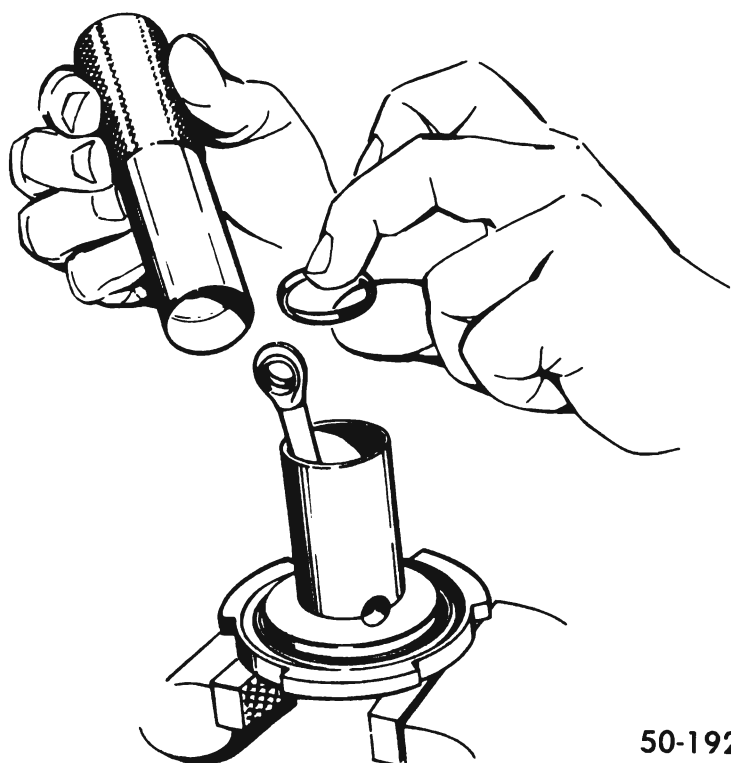

50-192

Figure 50-85 Installing Floating Control Valve Retainer With Installer J-23175

piston whenever the primary power piston, and/or the secondary power piston are replaced during servicing. When using the factory-gaged power piston kit containing both the primary and secondary power pistons with one reaction piston, the gaging operation will not be necessary. This gaging operation is not required if neither power piston is replaced during servicing.

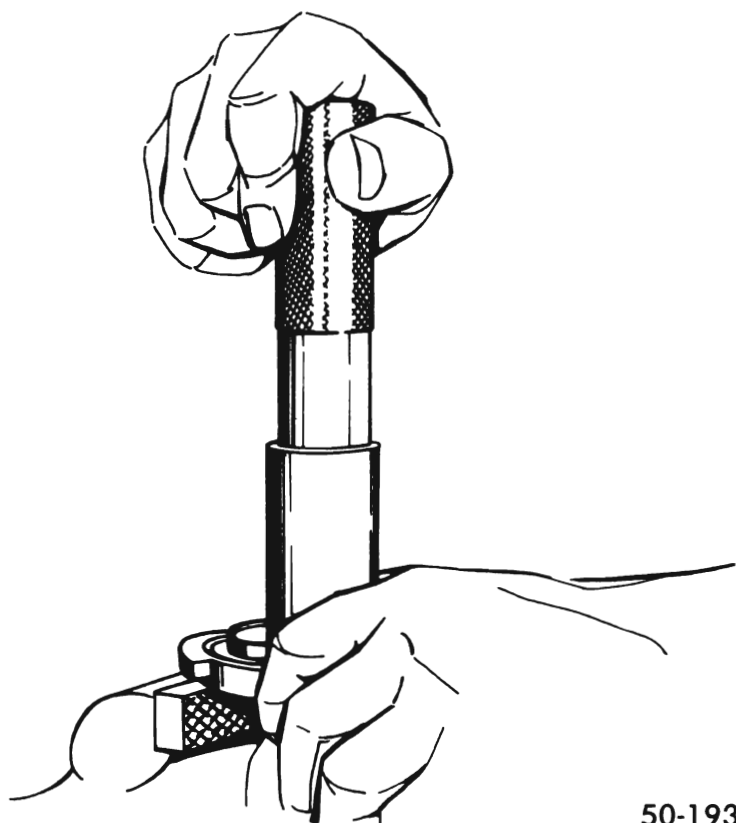

50-193

Figure 50-86 Seating Floating Control Valve Assembly With Installer J-23175

11. The following procedure should be followed if a selective reaction piston kit is required for servicing:

(a) Hand-tighten the secondary power piston to the primary power piston without the air valve spring. (The air valve push rod assembly should already be assembled to the primary power piston as described above.)

(b) Insert the reaction piston into its cavity in the secondary power piston. This is accomplished by placing the reaction piston, small diameter first, through the large cavity and into the smaller cavity. See Figure 50-87.

(c) With the secondary power piston up, push on the reaction piston to insure that it is seated on the air valve.

(d) Place Gage J-23337 in the secondary power piston so that the outer edges of the gage rest on the bottom of the large cavity, with the two levels of the center section of the gage within the smaller reaction piston cavity.

(e) Move the gage to the left or right of the "nose" of the reaction piston. The reaction piston is the correct length if the "nose" of the piston "hits" the lower level of the gage and clears the higher level of the gage, while permitting the outer edges of the gage to remain seated on the large cavity of the secondary power piston.

(f) If the reaction piston is too long, the higher level of the gage will not clear the "nose" without moving the outer edges of the gage off the seat in the large cavity of the secondary power piston. If the reaction piston is too short, both levels of the gage will clear the "nose" of the reaction piston. If either condition exists, a separate kit of three selective reaction pistons (differing in length and color) must be obtained to permit use of piston to meet correct size requirements of step (e) above.

12. After determination of the correct reaction piston, apply a light film of silicone lubricant to the O.D. of the rubber reaction disc.

13. Place the rubber reaction disc in the large cavity of the secondary power piston and push the disc down to seat on the reaction piston.

14. Unlock the secondary power piston from the primary power piston.

15. Assemble the primary diaphragm to the primary support plate from the side of the support plate opposite the locking tangs. Press the raised flange on the I.D. of the diaphragm through the center hole of the support plate. Be sure that the edge of the support plate center hole fits into the groove in the raised flange of the diaphragm. Lubricate the diaphragm I.D. and the raised surface of the flange (that fits into a groove in the primary power piston) with a light coat of silicone lubricant.

16. Mount Tool J-23101 (small diameter end up) in a vise. Position the primary power piston so that the two radial slots in the piston fit over the ears (tang) of the tool. See Figure 50-80.

17. Fold the primary diaphragm away from the O.D. of the primary support plate.

18. Holding the edges of the support plate, with the locking tangs down, place the primary support plate and diaphragm assembly over the tube of the primary power piston. The flange of the I.D. of the primary diaphragm will fit into a groove in the primary power piston.

19. Grip the edges of the primary support plate, press down, and rotate clockwise until the tabs on the primary power piston contact the stops on the support plate. See Figure 50-81.

POWER PISTON GAGING

REMOVE RUBBER REACTION DISC, PISTON ROD RETAINER & AIR VALVE SPRING FOR GAGING
GAGE - J23337 - BUICK

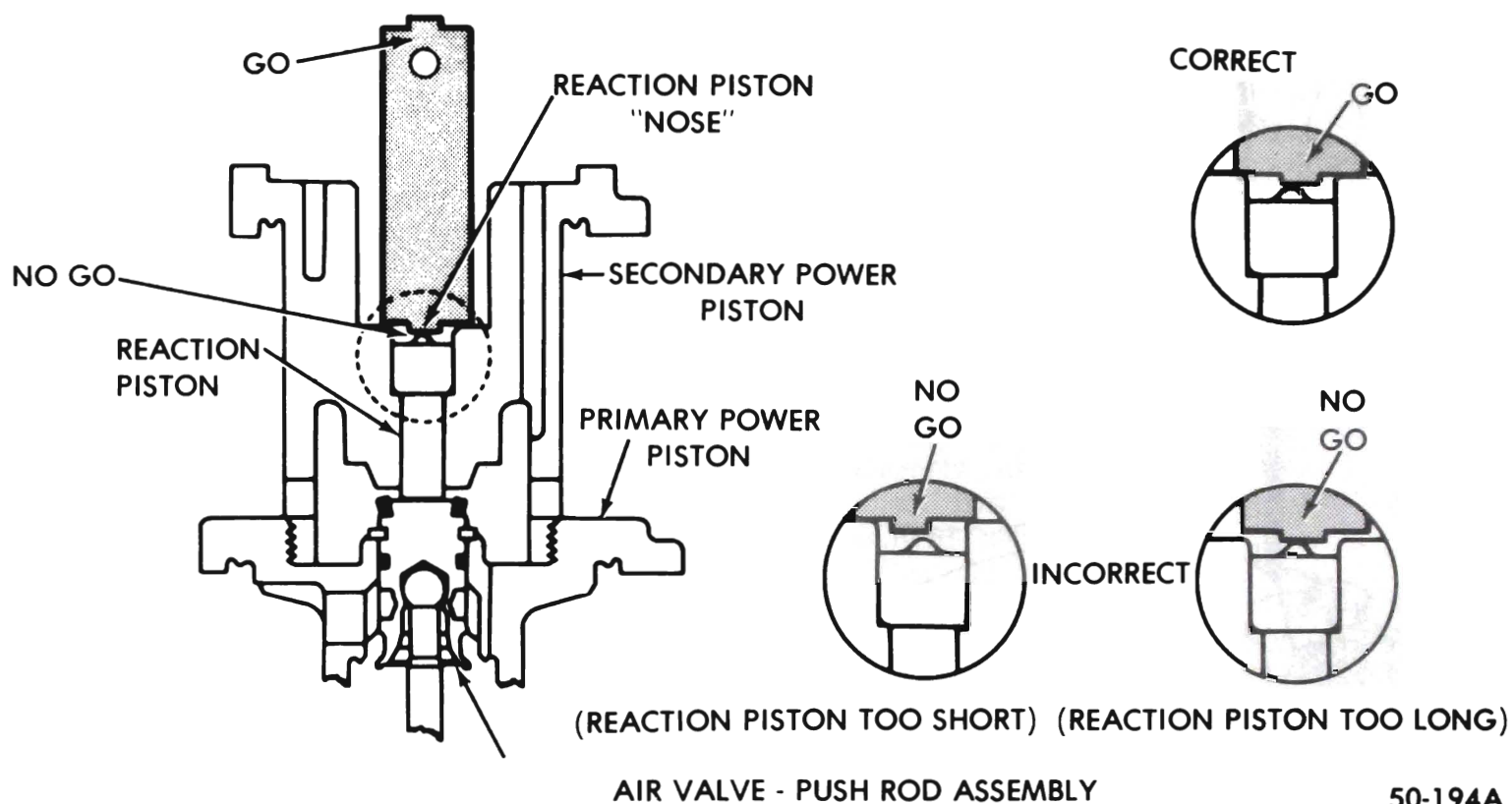

Figure 50-87 Power Piston Gaging

20. Place the power head silencer on the tube of the primary power piston so that the holes at the base of the tube are covered.

21. Apply silicone lubricant to the O.D. of the primary power piston tube.

22. Remove the primary piston assembly from Tool J-23101 and lay it aside.

23. Assemble the secondary diaphragm to the secondary support plate from the side of the support plate opposite the locking tangs. Press the raised flange on the I.D. of the diaphragm through the center hole of the support plate. Be sure that the edge of the support plate center hole fits into the groove in the raised flange of the diaphragm. Apply a thin coat of silicone lubricant to the I.D. of the secondary diaphragm and the raised surface of the flange (that fits into a groove in the secondary power piston).

24. Mount Tool J-23101 (with large diameter end up) in a vise. Position the secondary power piston so that

the radial slots in the piston fit over the ears (tang) of the tool. Apply a light coat of silicone lubricant to the tube of the secondary power piston. See Figure 50-76.

25. Fold the secondary diaphragm away from the O.D. of the secondary support plate.

26. Holding the edges of the support plate, with the locking tangs down, place the secondary diaphragm and support plate assembly over the tube of the secondary power piston. The flange on the I.D. of the secondary diaphragm will fit into the groove in the secondary piston.

27. Grip the edges of the secondary support plate, press down, and rotate counterclockwise until the tabs on the secondary power piston contact the stops on the support plate. Fold the secondary diaphragm back into position on the secondary support plate. Leave the secondary power piston assembly on Tool J-23101 in the vise. See Figure 50-78.

28. Apply a light coat of talcum powder or silicone lubricant to the bead on the O.D. of the secondary

diaphragm. This will facilitate reassembly of front and rear housings.

29. Place the secondary diaphragm support ring on the secondary power piston assembly so that it rests on the edge of the diaphragm.

30. Hold the housing divider so that the formed over flange (that holds the primary diaphragm) of the divider faces down. Place the secondary bearing in the I.D. of the divider so that the extended lip of the bearing faces up.

31. Lubricate the I.D. of the secondary bearing with silicone lubricant.

32. Position secondary bearing protector Tool J-23188 on the threaded end of the secondary power piston. See Figure 50-88.

33. Hold the housing divider so the six oblong protrusions on the middle of divider faces up. Press the divider down over the tool and onto the secondary power piston tube where it will rest against the diaphragm support ring. Remove Tool J-23188 from secondary power piston; however, do not remove the secondary power piston sub-assembly from Tool J-23101.

34. Pick up the primary power piston assembly and fold the primary diaphragm away from the O.D. of the primary support plate.

35. Position the small end of the air valve return spring on the air valve so that it contacts the air valve retaining ring.

36. Position the primary power piston on the tubular portion of the secondary power piston, making sure that the air valve return spring seats down over the raised center section of the secondary piston.

37. Grip the edge of the primary support plate, press down, and start the threads on the secondary power piston into the threaded portion of the primary power piston by rotating in clockwise direction. See Figure 50-77.

38. Continue to tighten the primary power piston until it is securely attached (approximately 5-15 ft. pounds) to the secondary power piston.

39. Fold the primary diaphragm back into position on the primary support plate and pull the diaphragm O.D. over the formed flange of the housing divider. Check that the bead on the diaphragm is seated evenly around the complete circumference.

40. Wipe a thin film of silicone lubricant on the O.D. of the piston rod retainer. Insert the master cylinder piston rod retainer into the cavity in the secondary power piston so that the flat end bottoms against the rubber reaction disc in the bottom of the cavity.

E. Reassembly of Rear Housing Group

1. Place the primary power piston bearing in rear housing center hole so that the formed flange of the housing center hole fits into the groove of the primary power piston bearing. The thin lip of the bearing will protrude to the outside of the housing.

2. Coat the I.D. of the primary power piston bearing with silicone lubricant.

F. Final Assembly

1. Assemble the master cylinder onto the studs on the front housing. The locknuts can be assembled fingertight on the studs. Mount the front housing and master cylinder assembly in a vise, clamping on sides of master cylinder vent hole.

2. Position the power piston return spring over the inset in the front housing.

3. Assemble the power piston group to the rear housing by pressing the tube of the primary piston through the rear housing bearing. Press down until the housing divider seats in the rear housing and the primary power piston bottoms against the housing.

4. Place the piston rod retainer plate on the end of the power piston return spring in the front housing.

5. Hold the rear housing assembly (with mounting studs up) over the front housing. (Make sure that the piston rod retainer does not dislodge from the secondary power piston during this operation.) Position the rear housing so that when the tangs on the

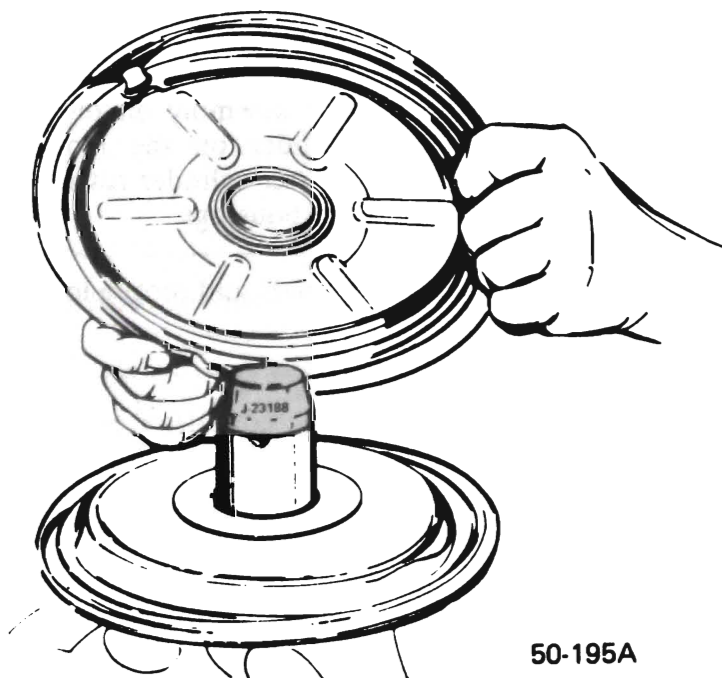

50-195A

Figure 50-88 Positioning Housing Divider Over Secondary Bearing Protector Tool J-23188

edge of the front housing are locked in the slots on the edge of the front housing, the scribe marks on the top of the housings will be in line.

6. Lower the rear housing assembly onto the front housing. Check that the piston rod retainer goes through the center of the retainer plate on the power piston return spring. The retainer plate and power piston spring must seat in the depression in the face of the secondary power piston. Check that the bead on the O.D. of the secondary diaphragm is positioned between the edges of the housing.

7. Continue to press down on the rear housing and fit the slots in the appropriate tangs on the front housing.

8. To facilitate locking, position front housing seal in the depression in the front housing and apply a vacuum source to the vacuum check valve in the front housing. Using Tool J-23456, press down and rotate the rear housing clockwise into the locked position. Remove Tool J-23456; remove the vacuum source. See Figure 50-74.

9. Place the silencer in the closed end of the power head boot. Push the boot retainer over the boot. Stretch the boot over the push rod and over the flange in the center of the rear housing.

50-33 GAGING TANDEM POWER BRAKE UNIT

1. Remove master cylinder from front housing.
2. Place the power head assembly in a padded vise (front housing up). *Do not clamp tight!*
3. Insert the master cylinder piston rod, flat end first, into the piston rod retainer.
4. Press down on the master cylinder piston rod (with approximately a 40-50 pound load) to be sure it is properly seated.
5. Remove the front housing seal to assure that no vacuum is in the power head while gaging.
6. Place Gage J-22647 over the piston rod in a position which will allow the gage to be slipped to the left or right without contacting the studs. See Figure 50-89.

DIVISION VI

SPECIFICATIONS

50-34 POWER BRAKE SPECIFICATIONS

Specifications for the Delco-Moraine Tandem Hydraulic Master Cylinder and the power brake unit are the same as listed for the Delco-Moraine drum brake unit, see Section A for Hydraulic Master Cylinder or Section D for power brake unit.

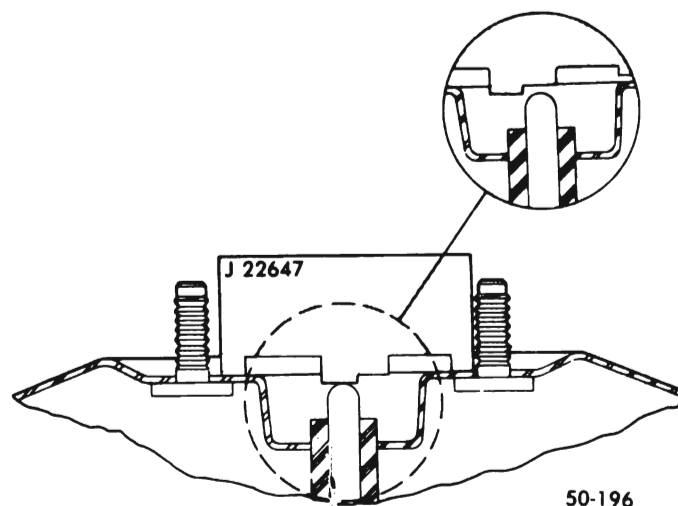

Figure 50-89 Gaging Piston Rod

7. The center section of the gage has two levels. The piston rod should always contact the longer section (lower level) of the gage. The piston rod should *never* contact the shorter section (higher level) of the gage. Move gage from side to side to check piston rod height.
8. Any variation beyond these two limits must be compensated for by obtaining the service adjustable piston rod and adjusting the self-locking screw to meet the gaging specifications.
9. Wipe a thin film of silicone lubricant on the I.D. of the front housing seal and position seal in the depression in the housing.
10. Install the master cylinder assembly on the front housing, positioning the cylinder on the mounting studs so that the top of the master cylinder reservoir is toward the scribe marks on the housings.
11. Assemble locknuts on the studs and torque to 25 lb. ft.

MASTER CYLINDER GROUP

Part	Inspect For	Corrective Action
Master Cylinder Body	1. Scratches, scores, pits, other damage affecting sealing or sliding action of piston seals in master cylinder bore.	1. Polish light damage smooth with crocus cloth; replace piece, if damage does not clean up quickly.
	2. Damaged threads.	2. Clean up or replace.
	3. Cracks, structural damage.	3. Replace
	4. By-pass and compensating holes to be open.	4. Open and clean passage.
Spring Retainers	1. Check for cracks, deformation.	1. Replace
Master Cylinder Primary and Secondary Pistons	1. Nicks, scratches, corrosion on finished O.D. surfaces.	1. Do not repair; replace.
	2. Small holes in end open.	2. Clean
	3. Try fit in master cylinder to be free with slight play.	3. Replace piston cylinder or both if tight or sloppy.
Master Cylinder Reservoir Diaphragm	1. Hardness, holes, punch marks, cuts or abrasion.	1. Replace
Power Pistons and Support Plates	1. Damaged threads.	1. Replace
	2. Cracks, distortion, chipping, pitted or rough holes, worn seal surfaces (tubes).	2. Clean up or replace.
Piston Rod Retainer	1. Cracks, distortion, chipping.	1. Replace
Air Valve Push Rod Assembly	1. Air Valve: scratches, dents, distortion, or corrosion of I.D. or O.D. All seats to be smooth and free of nicks and dents.	1. Do not repair; replace.
	2. Push rod must move freely in air valve, but must not pull out.	2. If worn, replace air valve push rod assembly.

- | | |
|--|------------|
| 3. Deterioration of rubber or warped valve face in floating control valve. | 3. Replace |
|--|------------|

OVERALL UNIT

Part	Inspect For	Corrective Action
Front and Rear Half Housing	1. Scratches, scores, pits, dents, or other damage affecting rolling or sealing diaphragm or other seals.	1. Replace, unless easily repaired.
	2. Cracks, damaged threads on studs, broken studs.	2. Replace, unless easily repaired.
	3. Bent or nicked locking lugs.	3. Replace, unless easily repaired.
	4. Loose studs.	4. Replace or repair.
Filter and Silencers	1. Dirty	1. Replace