

REAR SUSPENSION

ALL SERIES

CONTENTS

Subject	Page No.
DESCRIPTION AND OPERATION:	
Description of Rear Suspension	3H-170
Description of Rear Shock Absorbers	3H-171
DIAGNOSIS:	
Checking Rear Shock Absorbers	3H-171
Checking Rear Chassis Trim	3H-172
MAINTENANCE AND ADJUSTMENTS: (Not Applicable)	
MAJOR REPAIR:	
Rear Shock Absorbers - All Series	3H-172
Rear Springs - All Except X Series and B Series Wagon.....	3H-177
Rear Springs, Brackets, Bushings and Shackles - X Series.....	3H-177
Rear Springs - B Series Wagon	3H-179
Rear Lower Control Arms - All Except X and B Series Wagon.....	3H-179
Rear Upper Control Arms - All Except X and B Series Wagon.....	3H-180
SPECIFICATIONS:	
Rear Suspension Specifications	3H-181

DESCRIPTION AND OPERATION

DESCRIPTION OF REAR SUSPENSION

Rear Suspension - All Except X Series and B Series Wagon

The rear wheels are not independently sprung, being incorporated in the rear axle assembly. Alignment is maintained by the rigid rear axle housing.

The rear axle assembly is attached to the frame through a link type suspension system. Two rubber bushed lower control arms mounted between the axle assembly and the frame maintain fore and aft relationship of the axle assembly to the chassis. Two rubber bushed upper control arms, angularly mounted with respect to the centerline of the car,

control driving and braking torque and sideways movement of the axle assembly.

The upper control arms are shorter than the lower arms, causing the differential housing to "rock" or tilt forward on compression. This rocking or tilting lowers the rear propeller shaft to make possible the use of a lower tunnel in the rear floor pan area than would be possible with a conventional rear suspension. See Figure 3H-1.

The rear upper control arms control drive forces, side sway and pinion nose angle. Pinion angle adjustment can greatly affect car smoothness and must be maintained as specified.

The rear chassis springs are located between brackets on the axle tube and spring seats in the frame. The springs are held in the seat pilots by the weight of the car, with an insulator on top for noise isolation, and

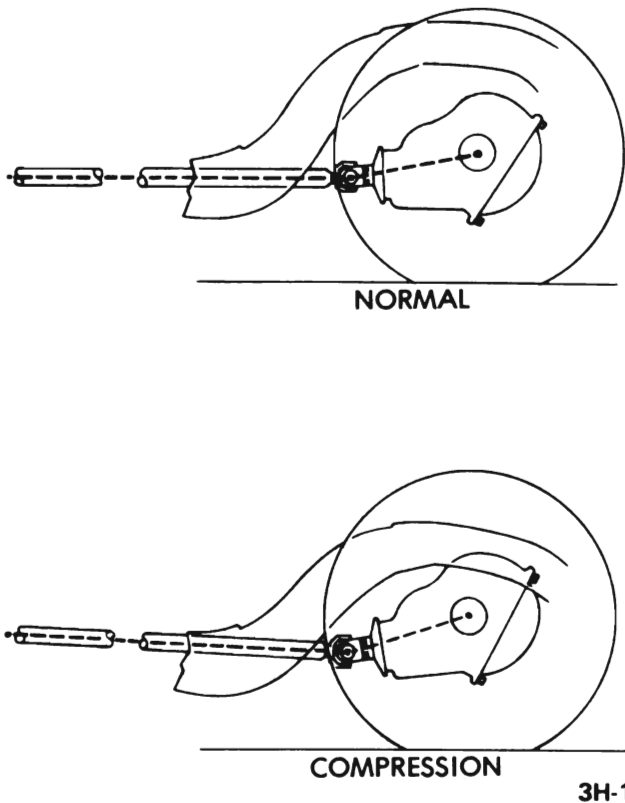

Figure 3H-1 - Differential Tilting Action

by the shock absorbers which limit axle movement during rebound.

Ride control is provided by two identical direct double acting shock absorbers angle-mounted between brackets attached to the axle housing and the rear spring seats.

Rear Suspension X Series and B Series Wagon

The rear wheels are not independently sprung, being incorporated into the rear axle assembly. The rear wheels are held in proper alignment with each other by the rigid construction of the axle housing. With the use of an open type drive line, driving and braking forces are taken by multi leaf springs.

Ride control is provided by two identical direct double acting shock absorbers angle-mounted between spring attaching plates at the axle housing and to the frame.

DESCRIPTION OF REAR SHOCK ABSORBERS

Shock Absorber Type and Location

Rear shock absorbers are Delco direct double action, (telescoping) hydraulic type. All shocks are filled with a calibrated amount of fluid and sealed during production; therefore, no refilling or other service is necessary or possible.

The upper end is attached to a frame bracket. The lower end is attached to a bracket welded to the rear axle tube.

The rear shock absorbers except for Superlifts are interchangeable with respect to left and right.

Front and rear are not interchangeable with each other.

DIAGNOSIS

CHECKING REAR SHOCK ABSORBERS

Many shock absorbers have been replaced and returned to the factory with the report that they were weak. When tested with special factory equipment, very few of these replaced units have been found weak or otherwise below standard in operation. This indicates that these shock absorbers were needlessly replaced in an attempt to improve riding conditions that were actually standard or that bad methods were used in judging the operating condition of the shock absorbers.

Slight dampness around piston rod seal is normal and represents fluid used to lubricate the piston rod and seal.

Before attempting to test shock absorbers, make sure that all attaching bolts and nuts are tight. Tires should be uniformly inflated to specified pressure. The chassis should be well lubricated to make sure that suspension parts are free moving.

Test each front and rear shock absorber in turn by quickly pushing down and then lifting up on the end of the car bumper adjacent to the unit being checked. Use the same force as near as possible on each test and note the amount of resistance provided by the shock absorber on compression and rebound. A little practice on another car of the same model which has satisfactory ride control will aid in judging the amount of resistance that should exist.

Both rear shock absorbers should provide the same feeling of resistance. Any noticeable variation between right and left shock absorbers indicates that one unit is not operating normally.

If there is any doubt about the action of a shock absorber after testing as described above, remove the unit from car. Mount it vertically in a vise with jaws gripping the lower mounting eye firmly, then move the piston rod up and down by hand several times. There should be no free movement in this test after cycling several times. Lack of resistance to movement indicates air in the shock absorber, or that the valve is held open by dirt. A faulty shock absorber must be replaced as it cannot be disassembled for

repairs. However, shocks should not be replaced in pairs (or car sets) to correct one faulty shock.

Do not operate shock absorber in a horizontal position or upside down. This will cause air to be trapped and shock will "lag" (appear defective).

In the test given above, the amount of force that can be applied is not sufficient to open a valve against its

spring pressure; therefore, this test only checks the flow of fluid through the valve bleeder hole or due to a valve being held open or due to internal wear of piston and cylinder.

Since it is unlikely that the valve springs will weaken in service, it may be assumed that the shock absorber action is normal if it operates satisfactorily in the test given above.

Condition	Test or Inspection Procedure
Incorrect, weak or inoperative shock absorbers	Visual inspection for oil-slight seepage is normal - could be oil spray from another source - replace if the shock is leaking excessively. Test each rear shock absorber in turn by quickly pushing down and then lifting up on the end of the bumper closest to the unit being checked. Use the same amount of force on each test and note the amount of resistance provided by the shock absorber on compression and rebound. For additional information, refer to Testing and Inspection of Shock Absorbers - this section.
Incorrect, weak or unmatched springs	Check trim height measurements with specifications. Either replace the spring with the correct unit or shim to the desired height. For additional information, refer to Measuring Trim Height and Installing Front Spring Shims - this section.

CHECKING REAR CHASSIS TRIM

Tire size, undercoating, accumulated dirt, etc., change the car weight and must be considered when checking trim height. Springs are computer selected for the specific options and tire size of the car. The dimensions given are the nominal standard car at curb weight and may vary slightly. Curb weight includes gas, oil, water and spare tire but no passengers or luggage. See Figure 3H-2, 3H-3, 3H-4 and 3H-5.

Before measuring spring dimensions, bounce both ends of car up and down several times to make sure there is no bind in suspension members and to let springs take a natural position.

MAJOR REPAIR

REMOVAL AND INSTALLATION OF REAR SHOCK ABSORBER - ALL SERIES

This Section covers the standard shock absorber only. See Group 9 Section F for Automatic Level Control.

Both rear shock absorbers are filled and sealed in production and cannot be refilled in service.

Removal

1. Raise rear of car and support rear axle assembly.
2. Disconnect shock at lower end. Disconnect shock at upper end and remove shock.

Installation

Do not operate shock absorber in a horizontal position. This will cause air to be trapped and shock will "lag" (appear defective).

1. Make certain that new shock absorber is correct for car model as indicated by part number stamped on the outer tube. Before installing new shock absorbers, place each one vertically in a vise and stroke through full travel until hydraulic resistance is smooth. This pumps trapped air out of the inner cylinder. Keep the shock in a vertical position until installed in the car.

2. Loosely attach shock at upper and lower mounting

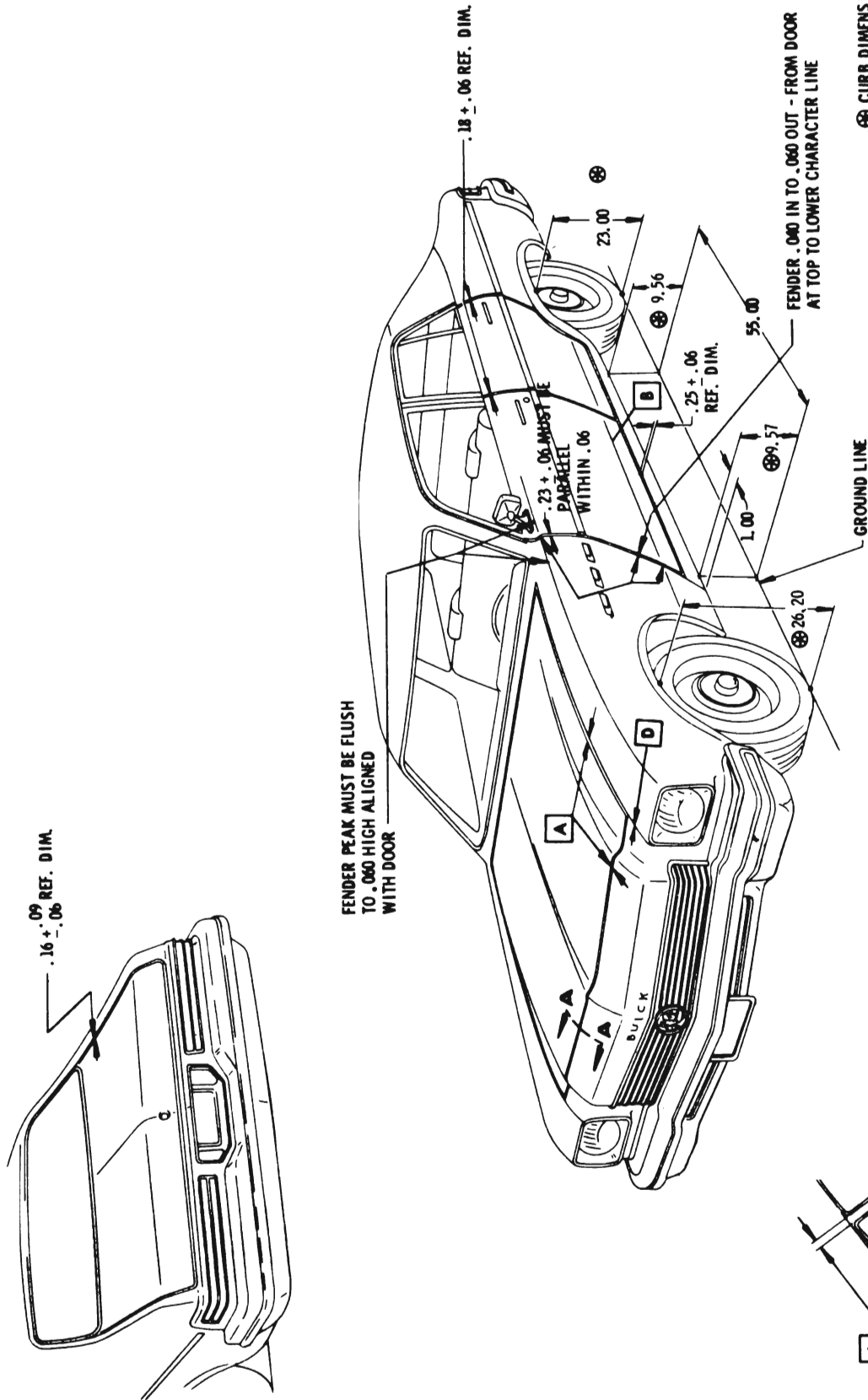

⊕ CURB DIMENSIONS

OVERALL LENGTHS LESS BUMPER & RELATED ATTACHING PARTS.

COUPES & SEDANS 19L 90

4BBA9

Figure 3H-2 "X" Series Trim Dimensions

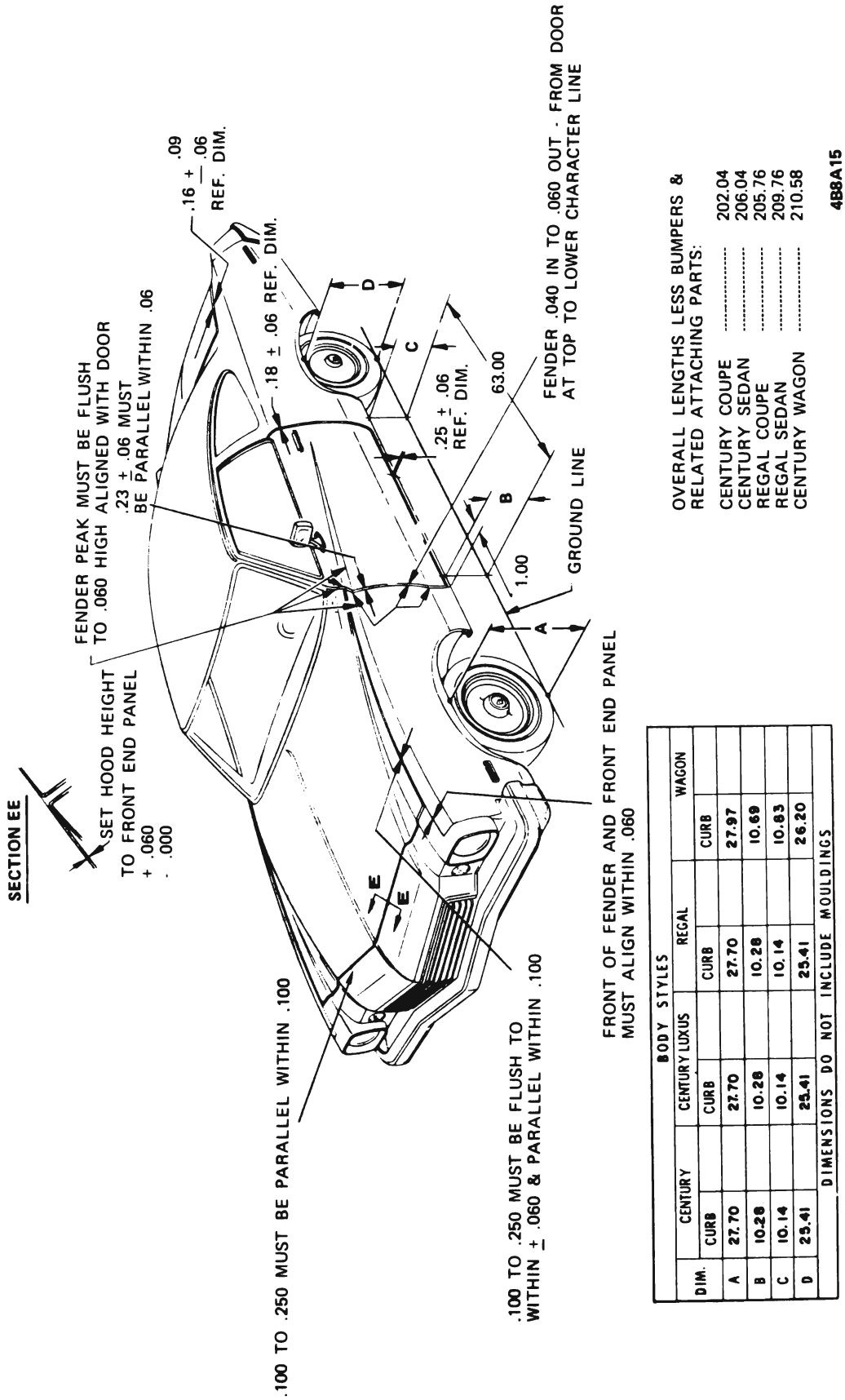
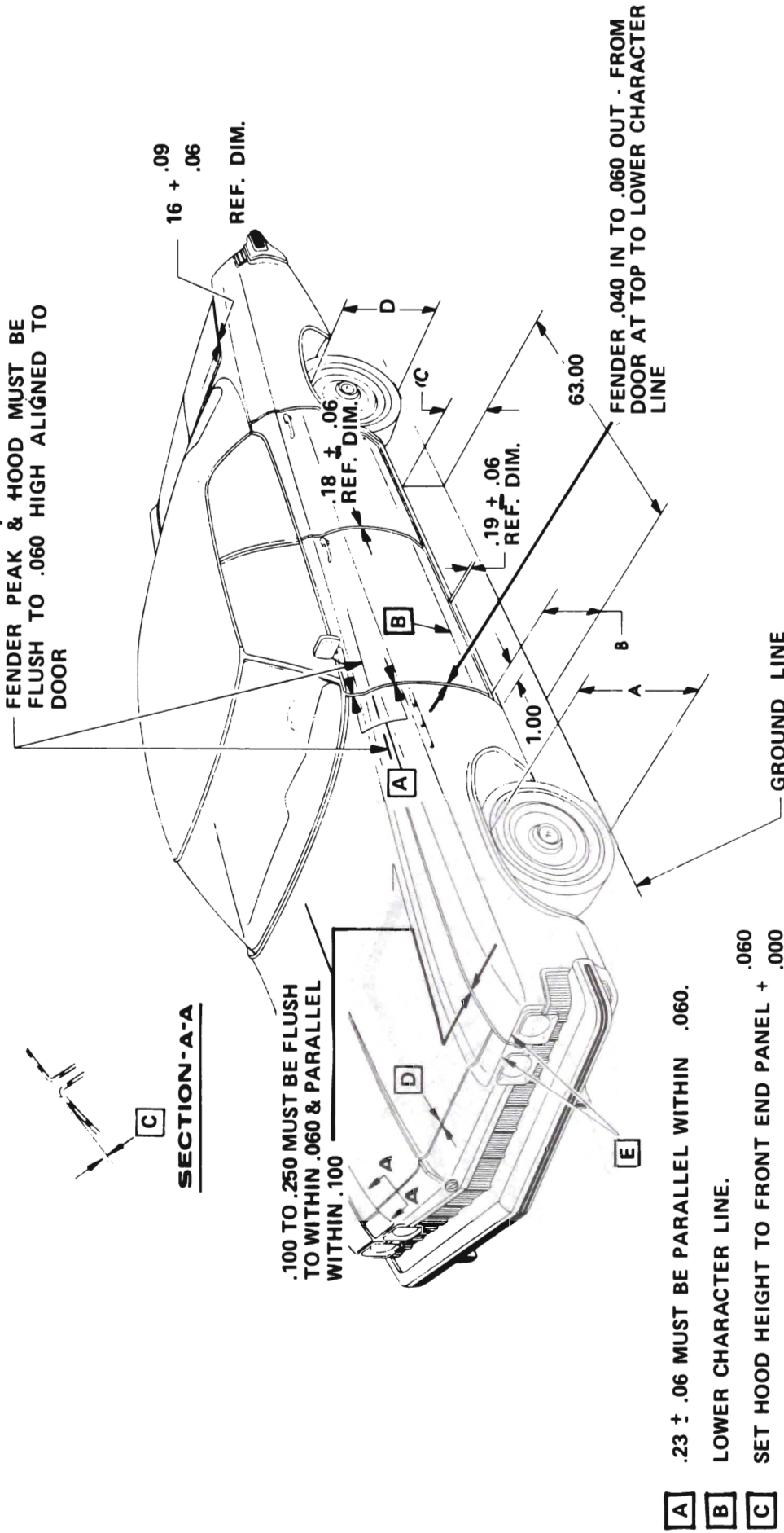

Figure 3H-3 "A" Series Trim Dimensions



- A** .23 ± .06 MUST BE PARALLEL WITHIN .060.
- B** LOWER CHARACTER LINE.
- C** SET HOOD HEIGHT TO FRONT END PANEL + .060
- D** .100 TO .250 AND PARALLEL WITHIN .100
- E** FRONT OF FENDER & FRONT END PANEL MUST ALIGN WITHIN .06.

OVERALL LENGTHS LESS BUMPERS & RELATED ATTACHING PARTS:

LESABRE & LESABRE LUXUS	-----	218.14
ESTATE WAGON	-----	222.18
ELECTRA	-----	222.36

HEIGHTS WITH AUTOMATIC LEVEL CONTROL ARE IDENTICAL TO CURB HEIGHTS.

DIM	LESABRE	ESTATE WAGON	LESABRE LUXUS	ELECTRA
	CURB	CURB	CURB	CURB
A	28.48	29.36	28.48	28.62
B	9.26	10.20	9.26	9.40
C	9.16	10.21	9.16	9.30
D	24.32	25.42	24.32	24.30

DIMENSIONS DO NOT INCLUDE MOULDINGS

4B8A20

Figure 3H-4 "B-C" Series Trim Dimensions

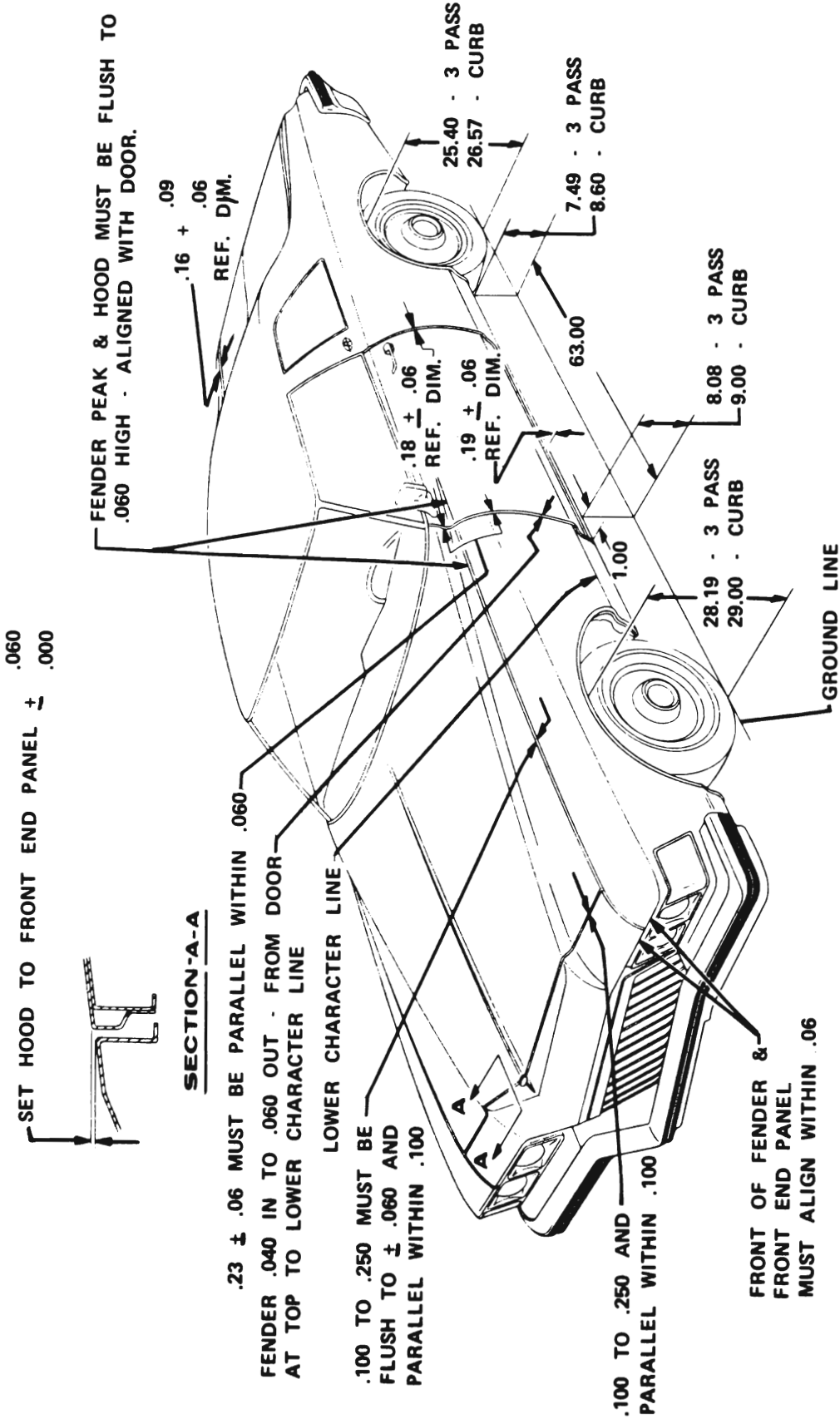

OVERALL LENGTH LESS BUMPERS & RELATED ATTACHING PARTS = 217.86

MOULDINGS NOT INCLUDED IN DIMENSIONS
HEIGHTS WITH AUTOMATIC LEVEL CONTROL ARE IDENTICAL TO CURB HEIGHTS

488A24

Figure 3H-5 "E" Series Trim Dimensions

points. While observing the following, tighten mounting parts to specified torque.

Car weight must be on rear wheels when tightening shock absorber lower ends in order to clamp rubber bushings in a neutral or unloaded position.

Substitution with other part number shock than specified can alter handling and ride characteristics and are not normally recommended.

REMOVAL AND INSTALLATION OF REAR CHASSIS SPRING - ALL EXCEPT X SERIES AND B SERIES WAGON

Removal

1. Raise the rear end of the car and support the frame on jack stands.
2. Disconnect the shock absorbers at the axle bracket lower mount.
3. Disconnect the upper control arms at the differential.
4. Slowly lower or separate the axle assembly from the car body to the point where the springs become loose enough to allow removal.

Installation

1. Position spring in correct position. Make sure that the insulator is in position on top of the spring.
2. Reposition the rear axle in correct relationship with the body by raising the axle or lowering the body.
3. Connect the shock absorbers at the lower mounting bracket. Do not tighten to specified torque unless car weight is on the rear axle.
4. Connect the upper control arms, but do not tighten to specified torque unless car weight is on rear axle.
5. Lower the car to the ground.

REMOVAL AND INSTALLATION OF REAR SPRING, BRACKETS, BUSHINGS AND SHACKLES - X SERIES

Spring Removal

1. Raise vehicle on hoist. Support vehicle so axle can be raised and lowered.

2. Raise axle assembly so that all tension is removed from spring.

3. Disconnect shock absorber lower attaching mount.

4. Loosen the spring front eye-to-bracket retaining bolt.

5. Remove the screws securing the spring front bracket to the underbody.

6. Lower axle assembly sufficiently to permit access to spring front bracket and remove bracket from spring.

7. The spring eye bushing can be replaced without completely removing the spring from the vehicle. Refer to Bushing Replacement procedure.

8. Pry parking brake cable out of the retainer bracket mounted on the spring mounted plate.

9. Remove lower spring plate-to-axle bracket retaining nuts.

10. Remove upper and lower rubber spring pads and spring plate.

11. Support spring, then remove upper bolt from spring rear shackle. Lower so that bottom bolt may be removed. Separate shackle and withdraw spring from vehicle.

Bushing Replacement

The spring eye bushing can be replaced without complete spring removal.

1. Position remover adapter J-21978-1 over puller screw J-21058-15 so that adapter is against head of puller screw. Refer to Figure 3H-6 for view of removal tools.

2. Position puller screw through eye of bushing so that remover adapter J-21978-1 is against unflanged side of bushing.

3. Position large end of barrel J-22553-1 over puller screw and seat barrel against spring eye.

4. Position thrust bearing on puller screw then install and tighten nut J-21058-8 against thrust bearing.

5. Check to make sure that all puller parts are properly aligned than proceed to tighten nut until bushing is pulled free of spring eye disassemble puller tool.

6. Position installer adapter J-22553-2 over flange end of bushing then position puller screw J-21058-15

through installer adapter and bushing. Refer to Figure 3H-7 for view of installation tools.

7. Position puller screw through spring eye until bushing contacts spring. Install small end of barrel J-22553-1 over puller screw and seat barrel against spring.

8. Install thrust bearing and nut J-21058-8. Check puller tools and bushing for proper alignment; then tighten nut to pull bushing into spring.

Do not apply additional torque to nut J-21058-8 after bushing flange contacts spring. Unnecessary torque applied after flange is seated will tend to distort flange and reposition bushing in spring.

9. Disassemble bushing installation tools and remove from spring.

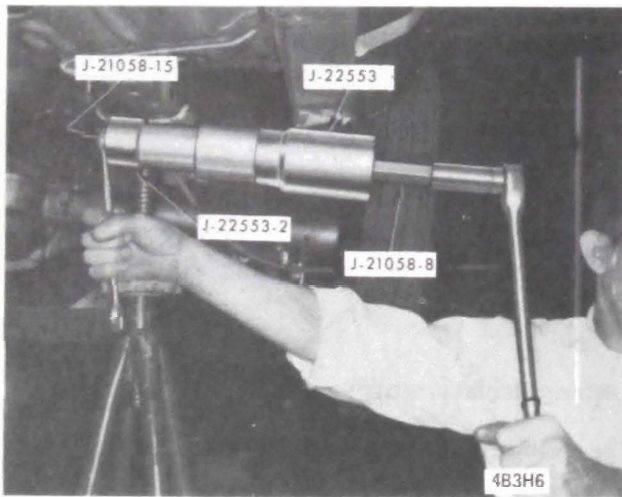

Figure 3H-6 Removing Spring Front Bushing X Series

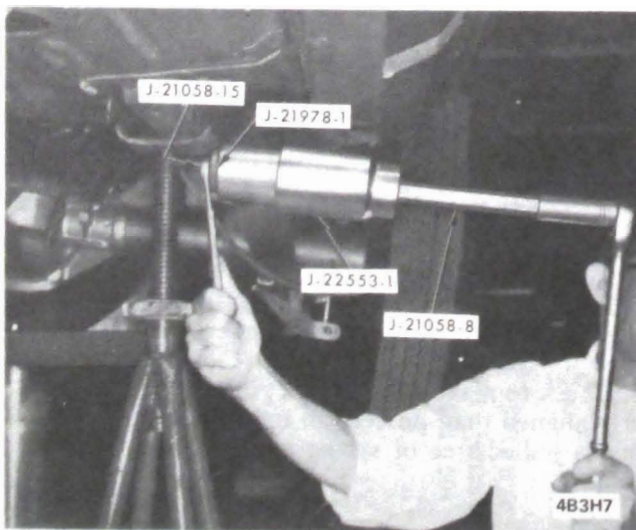

Figure 3H-7 Installing Spring Front Bushing X Series

Spring Disassembly

Spring leaves are not serviced separately.

1. Place spring assembly in a bench vise and remove spring clips.
2. Position spring in vise jaws, compressing leaves at center and adjacent to center bolt.
3. File peened end of center bolt and remove center bolt nut. Open vise slowly to allow spring assembly to expand.
4. Replace any defective spring leaf inserts.
5. Align center holes in spring by means of a drift and compress spring leaves in a vise.
6. Remove drift from center hole and install a new center bolt - peen bolt to retain nut.
7. Align spring leaves by tapping with hammer, then bend spring clips into place.

Spring clips should be tightened sufficiently to maintain alignment, but not tight enough to bind spring action.

Spring Installation

1. Position spring front mounting bracket to spring front eye. Spring attaching bolt must be installed so that head of bolt is toward center of vehicle.
2. Install bushing halves in spring rear eye, place spring to shackles and loosely install shackle lower bolt and nut.
3. Position spring shackle upper bushings in frame. Position shackles to bushings and loosely install bolt and nut.

When installing spring, make sure spring is positioned so that parking brake cable is on underside of spring.

4. Raise front end of spring and position bracket to underbody. Guide spring into position so that it will index in the axle bracket and also make sure that the tab on spring bracket is indexed in slot provided in the underbody.
5. Loosely install spring-to-underbody bracket.
6. Position spring upper cushion between spring and axle bracket so that spring cushion ribs align with axle bracket locating ribs.
7. Place lower spring cushion on spring so that cush-

ion is indexed on locating dowel. Upper cushion and lower cushion will be aligned if installation is correct.

8. Place lower mounting plate over locating dowel on spring lower pad and loosely install retaining nuts.

9. If new mounting plate was installed, transfer parking brake cable retaining bracket to new plate.

10. Attach shock absorber to spring mounting plate.

11. Position parking brake cable in retaining bracket and securely clamp bracket to retain cable.

12. Torque all affected parts to specifications with vehicle weight on suspension components.

CAUTION: *Fasteners are important attaching parts in that they could affect the performance of vital components and systems, and/or could result in major repair expenses. They must be replaced with one of the same part number or with an equivalent part if replacement becomes necessary. Do not use a replacement part or lesser quality or substitute design. Torque values must be used as specified during reassembly to assure proper retention of these parts.*

13. Lower vehicle and remove from hoist.

REMOVAL AND INSTALLATION OF CHASSIS SPRINGS - B SERIES WAGON

Removal

1. Raise car on hoist. Use care not to crush exhaust system kick under pipe when using an axle engaging hoist.

2. Disconnect shock at lower attachment by removing nut.

3. Support car by placing jack stands at frame in front of leaf springs and at rear of leaf springs at bumper. It is also necessary to support axle.

4. Disconnect right side of exhaust system by removing exhaust hanger screw to rear frame cross member support exhaust system.

5. Remove lower spring plate attaching nuts.

6. Remove front and rear attaching bolts and remove spring.

Installation

1. Connect leaf spring at front attachment.

2. Lubricate rubber spring cushions and attach lower spring plate. It may be necessary to lower axle to attach spring plate. Torque nuts to specifications.

3. Attach leaf spring at rear shackle. Torque nut to specifications.

4. Torque nut at front attachment to specifications.

5. Reconnect shock.

6. Reconnect exhaust system.

7. Remove jack stands and lower hoist.

8. Refer to Rear Axle Group for pinion joint angle adjustment.

REMOVAL AND INSTALLATION OF REAR LOWER CONTROL ARM

WARNING: IF BOTH RIGHT AND LEFT LOWER CONTROL ARMS ARE TO BE REPLACED, ONE SIDE SHOULD BE COMPLETED BEFORE OPPOSITE SIDE IS STARTED IN ORDER TO KEEP AXLE FROM ROTATING OUT OF POSITION.

Removal

1. With axle housing and frame supported, remove lower control arm rear bracket bolt. If some difficulty is encountered in removing bolt, reposition jack farther forward under nose of carrier and slowly raise to relieve pressure and bind at control arm bushing. It may be necessary to use suitable brass drift to tap out bolt.

2. Remove lower control arm front bracket nut and bolt. After nut is removed, it may be necessary to tap out bolt with brass drift. Remove lower control arm.

Installation

CAUTION: *Fasteners in steps 1 and 2 are important attaching parts in that they could affect the performance of vital components and systems, and/or could result in major repair expense. They must be replaced with one of the same part number or with an equivalent part if replacement becomes necessary. Do not use a replacement part or lesser quality or substitute design. Torque values must be used as specified during reassembly to assure proper retention of these parts.*

1. Position control arm in front bracket and install bolt and nut. Do not tighten.

2. Raise or lower nose of axle slowly with jack until bushing in arm and holes in axle bracket align. Install nut and bolt.
3. Torque attaching nuts and bolts to specification.

Attaching parts should be tightened with suspension in curb load position.

REMOVAL AND INSTALLATION OF REAR UPPER CONTROL ARM

WARNING: IF BOTH RIGHT AND LEFT UPPER CONTROL ARMS ARE TO BE REPLACED, ONE SIDE SHOULD BE COMPLETED BEFORE OPPOSITE SIDE IS STARTED IN ORDER TO KEEP AXLE FROM ROTATING OUT OF POSITION.

Removal

1. Raise rear of car and support frame and rear axle assembly.
2. Disconnect control arm at axle housing by removing attaching nut and bolt.
3. Disconnect arm at frame by removing nut and bolt.

4. Remove upper arm assembly.

Installation

CAUTION: *Fasteners in steps 1 and 2 are important attaching parts in that they could affect the performance of vital components and systems, and/or could result in major repair expense. They must be replaced with one of the same part number or with an equivalent part if replacement becomes necessary. Do not use a replacement part or lesser quality or substitute design. Torque values must be used as specified during reassembly to assure proper retention of these parts.*

1. Position new arm in the frame bracket with nut and bolt. Do not tighten.
2. Align holes in bushing and holes in axle housing. Install nut and bolt. Torque attaching nuts and bolts to specification. Attaching parts should be tightened with suspension in curb load position.

It may be necessary to jack the carrier nose up or down slightly to align the mounting holes for bolt removal or installation.

SPECIFICATIONS

REAR SUSPENSION SPECIFICATIONS

Tightening Specifications

Use a reliable torque wrench to tighten the parts listed to insure proper tightness without straining or distorting parts. These specifications are for clean and lightly-lubricated threads only; dry or dirty threads produce increased friction which prevents accurate measurement of tightness.

Location	Torque Lb. Ft.
Rear Shock Upper Mounting Bolt	
All Series	20
Rear Shock Lower Mounting	
X Series	45
A-B-C-E Series	65
Upper and Lower Control Arm Bolt	
A Series	90
B-C-E Series	
Upper to Frame	95
Lower to Frame	95
Lower to Axle	135
Upper to Axle	85
Upper and Lower Control Arm Nut	
A Series	80
B-C-E Series	
Upper to Frame	85
Lower to Frame	85
Lower to Axle	100
Upper to Axle	75
Rear Prop. Shaft "U" Joint to Pinion Flange	
X-A-B Wagon Series	12-20
Rear Prop Shaft Flanged Yoke to Pinion Flange	
B-C-E Series	75-95
Leaf Spring U Bolt	
X-B Wagon Series	35-50
Leaf Spring Shackle Nuts	
X Series	40-60
B Wagon Series	75-95
Leaf Spring Front Eye Nut	
X Series	65-80
B Wagon Series	65-85

General Specifications

Shock Absorbers	Delco Direct Double-Acting
Springs	
A-B-C-E Series	Coil
X-B Wagon	Leaf

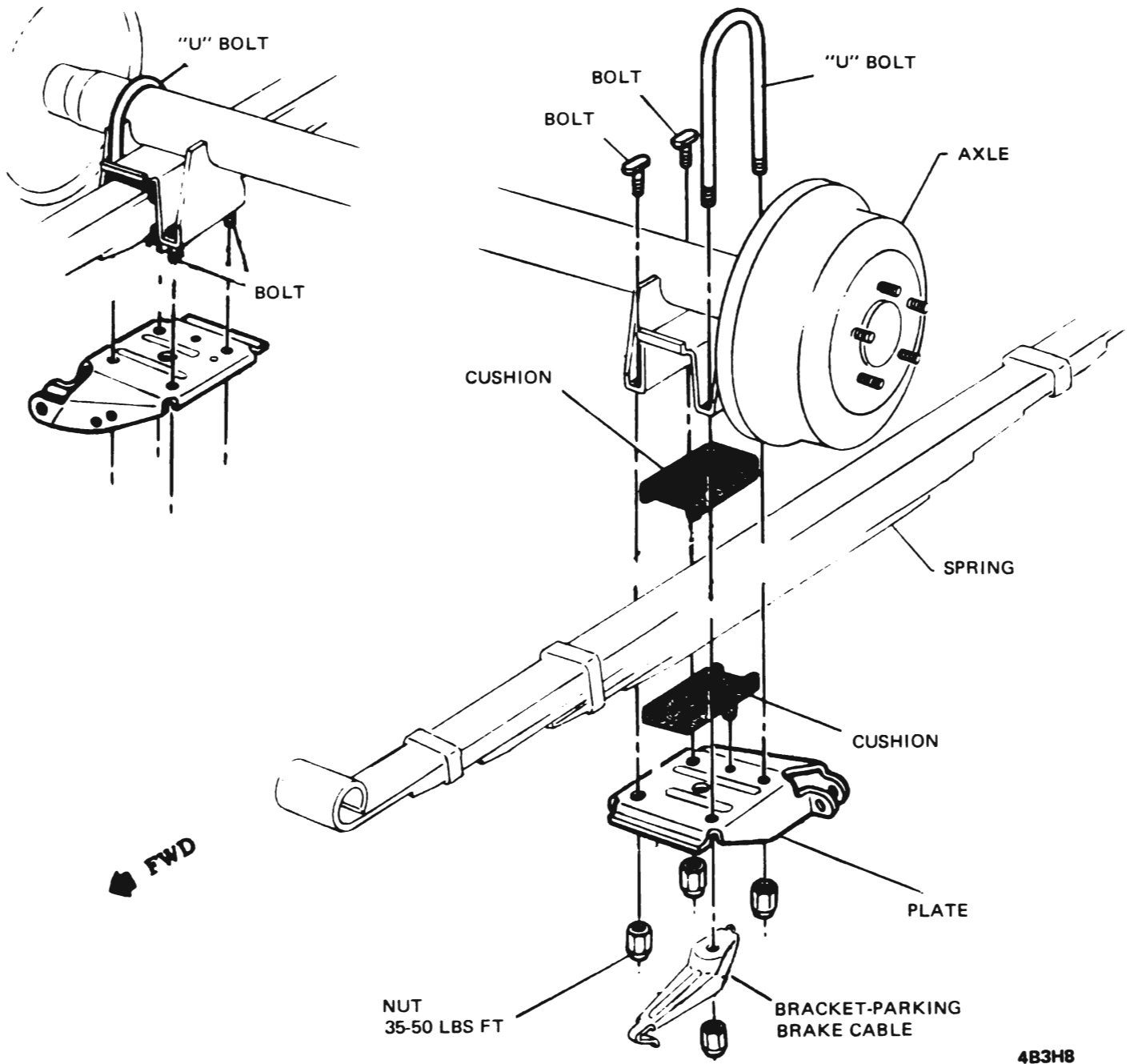
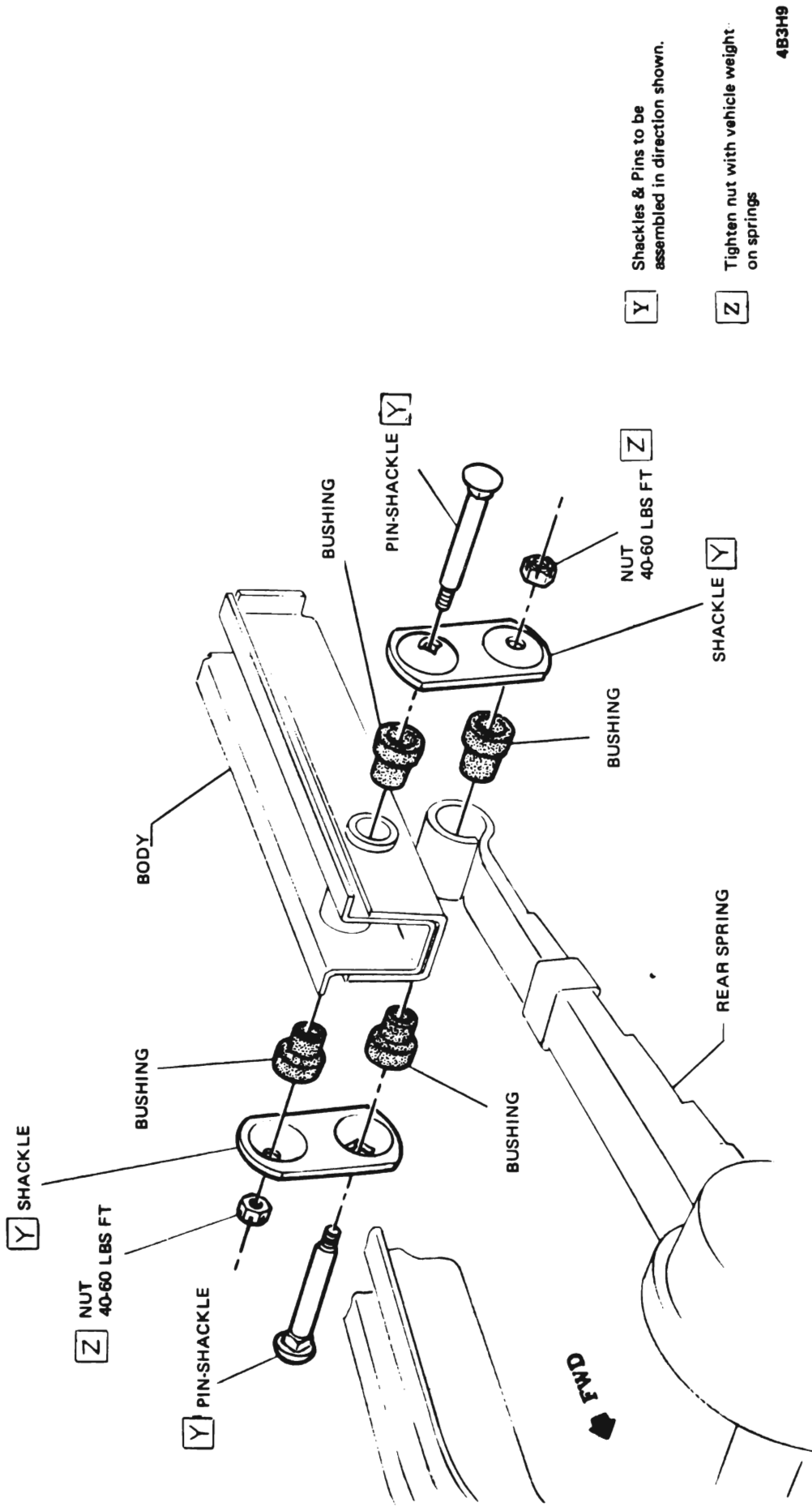

Figure 3H-8 X Series Rear Suspension



Y Shackles & Pins to be assembled in direction shown.

Z Tighten nut with vehicle weight on springs

483H9

Figure 3H-9 X Series Rear Shackles

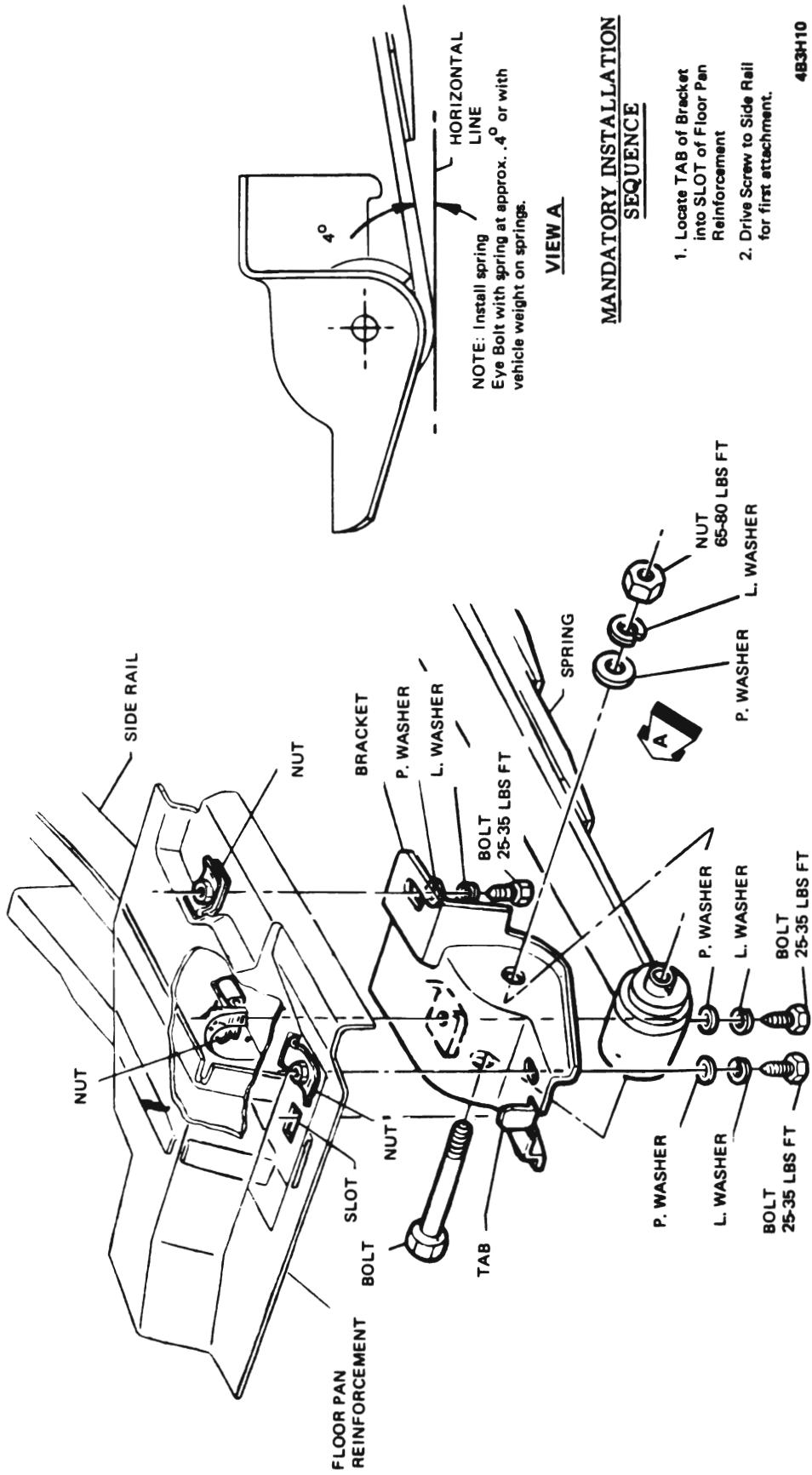

Figure 3H-10 X Series Rear Spring Front Bracket

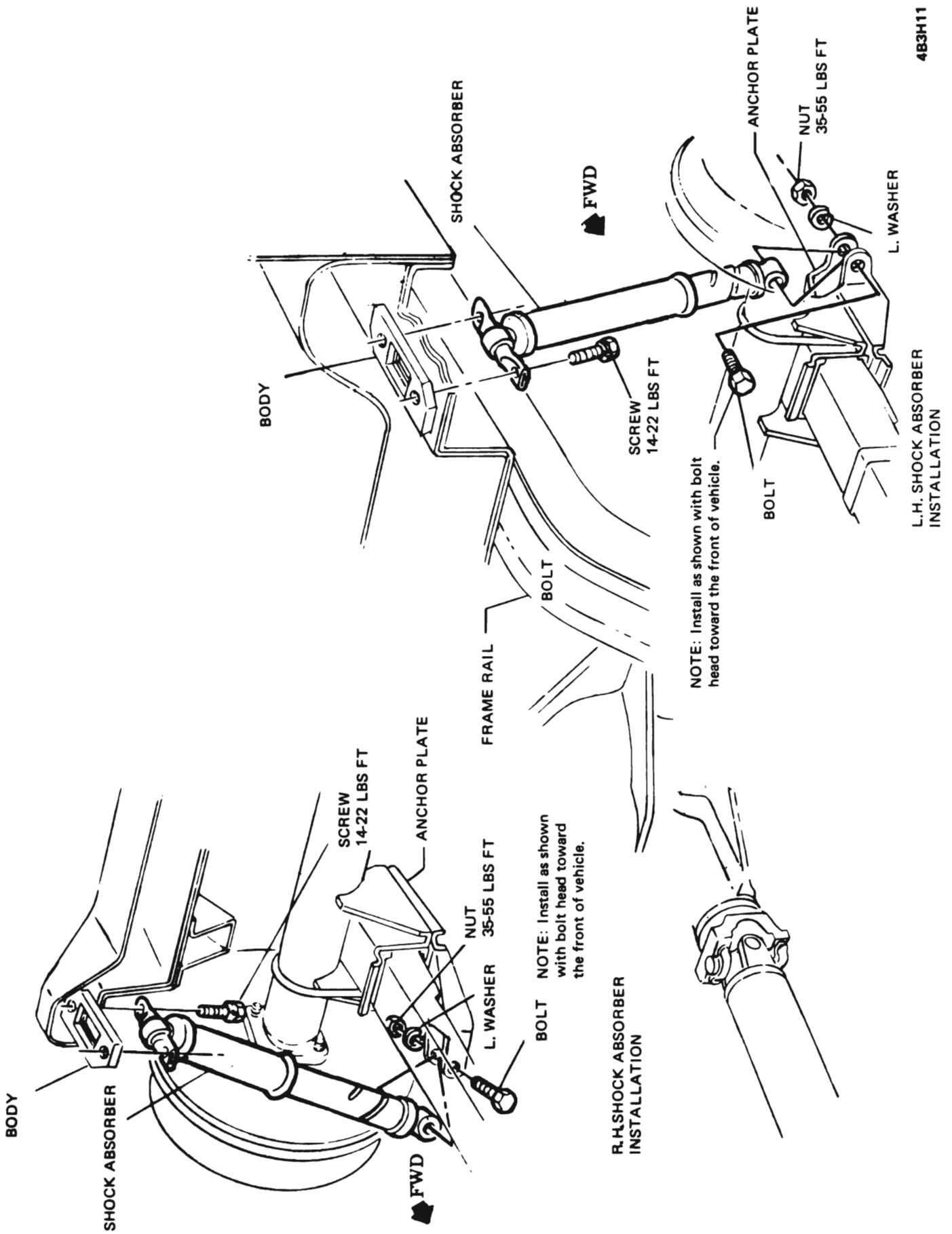

Figure 3H-11 X Series Rear Shock Mounting

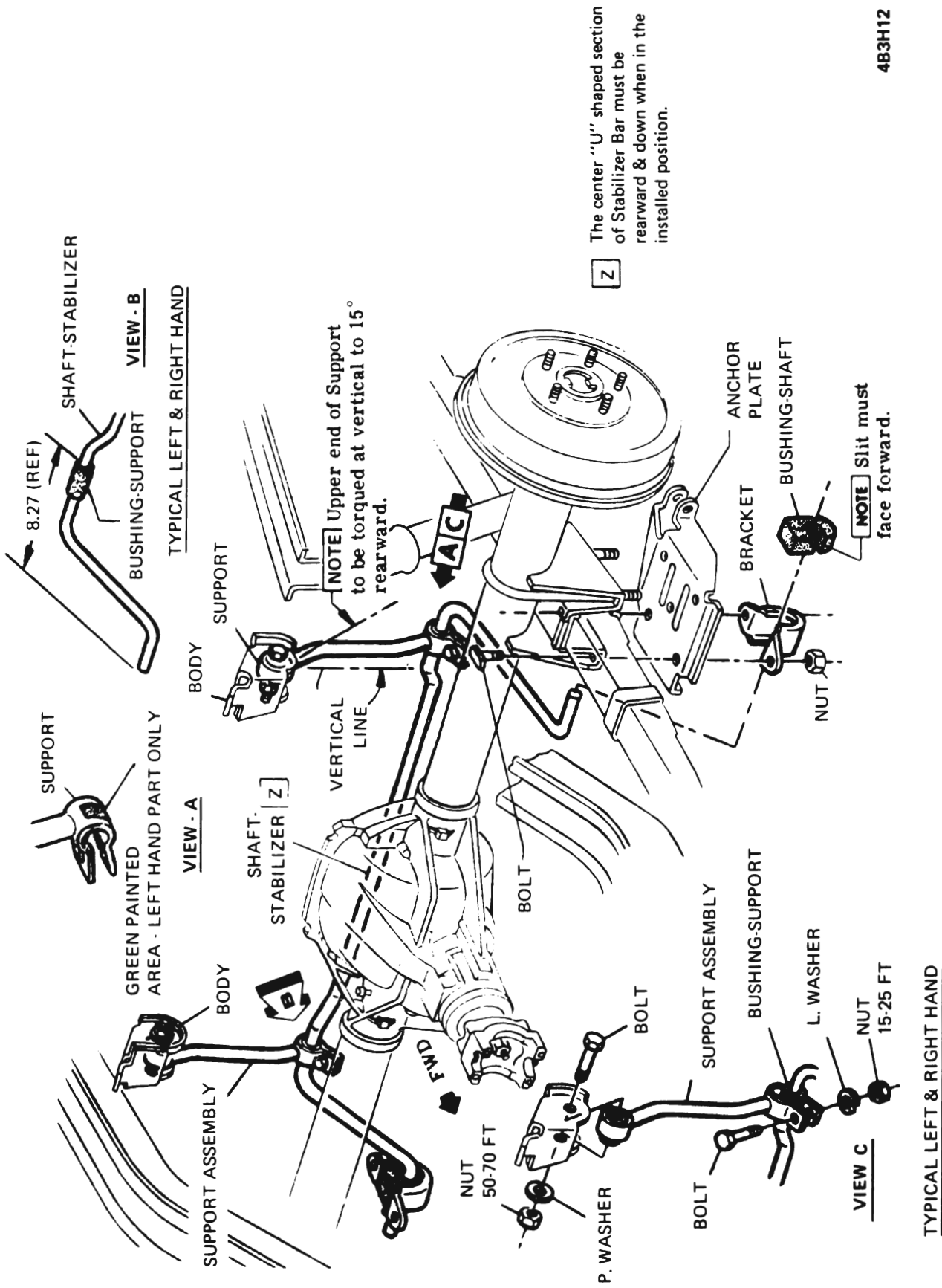
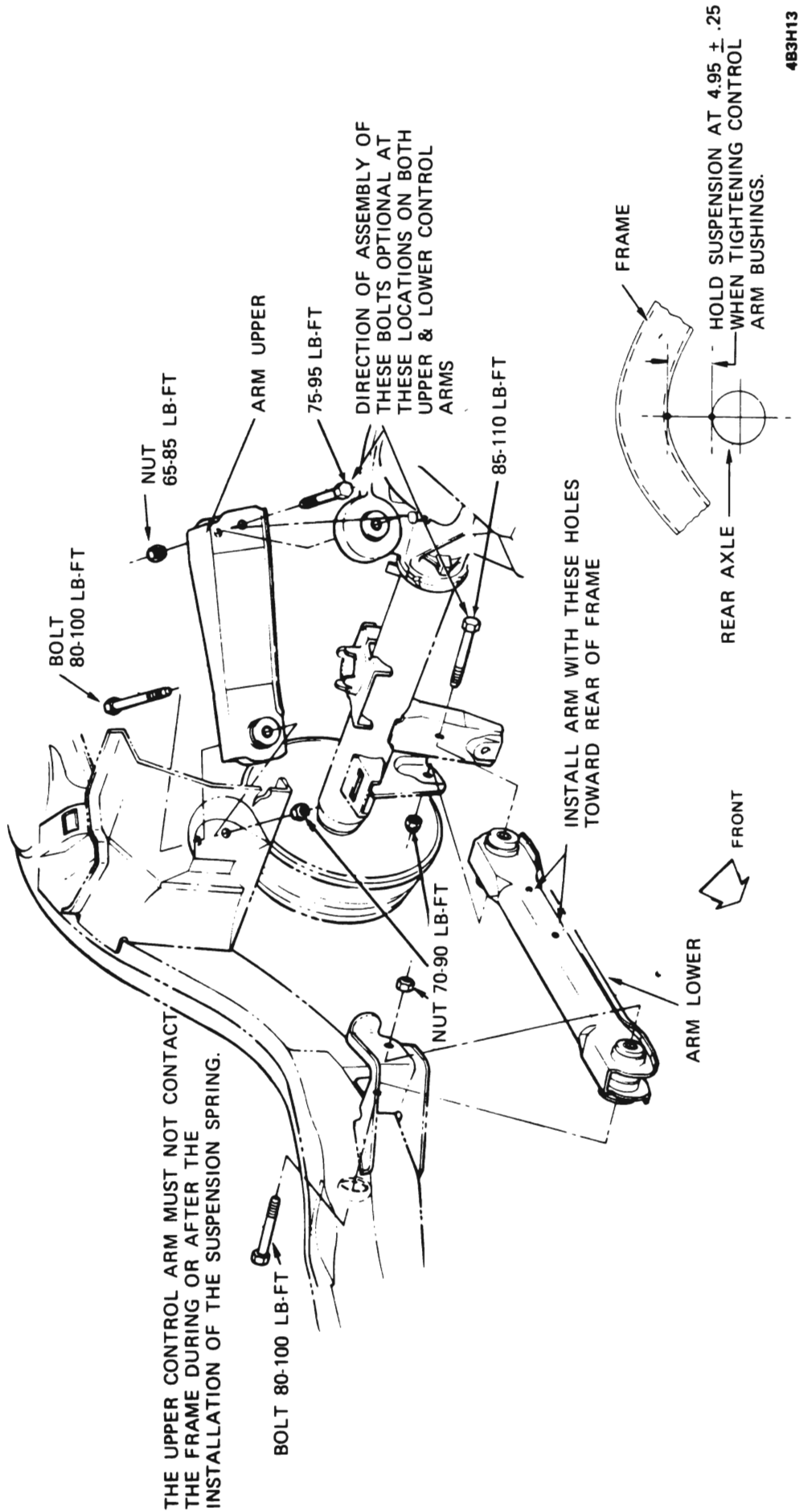

Figure 3H-12 X Series Stabilizer Bar



4B3H13

Figure 3H-13 A Series Rear Control Arms

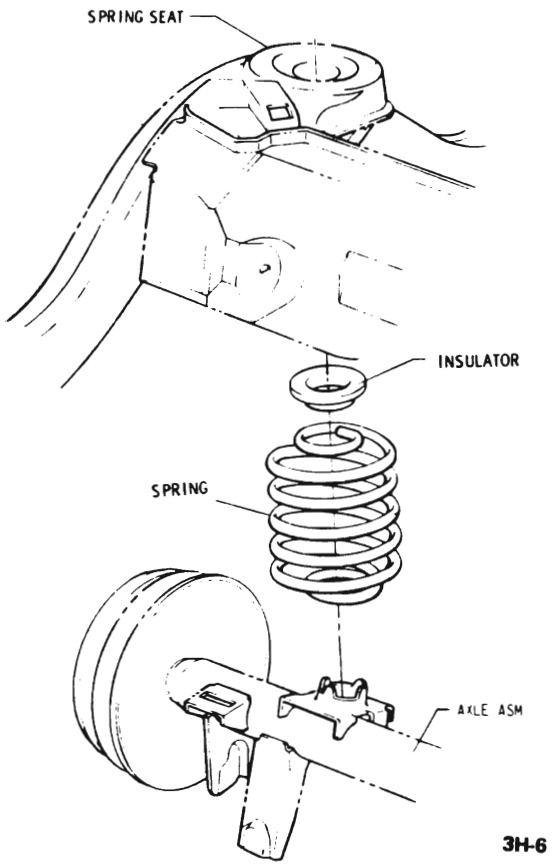

Figure 3H-14 A Series Rear Spring

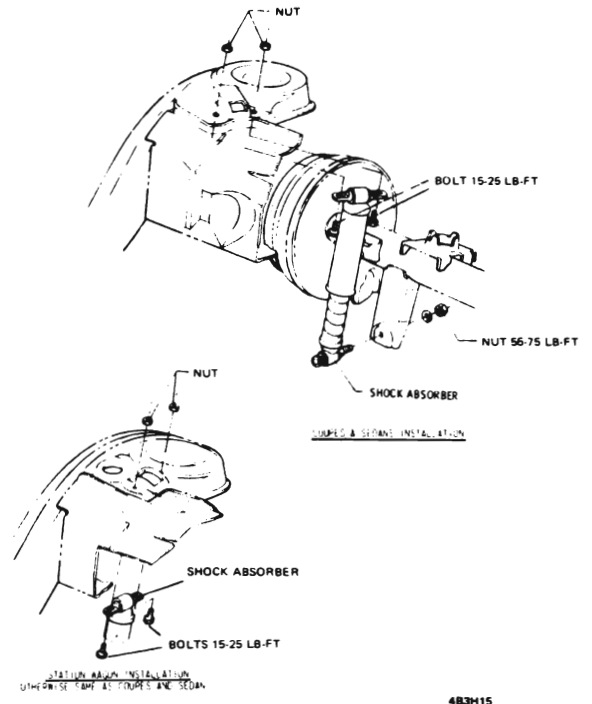

Figure 3H-15 A Series Rear Shock Mounting

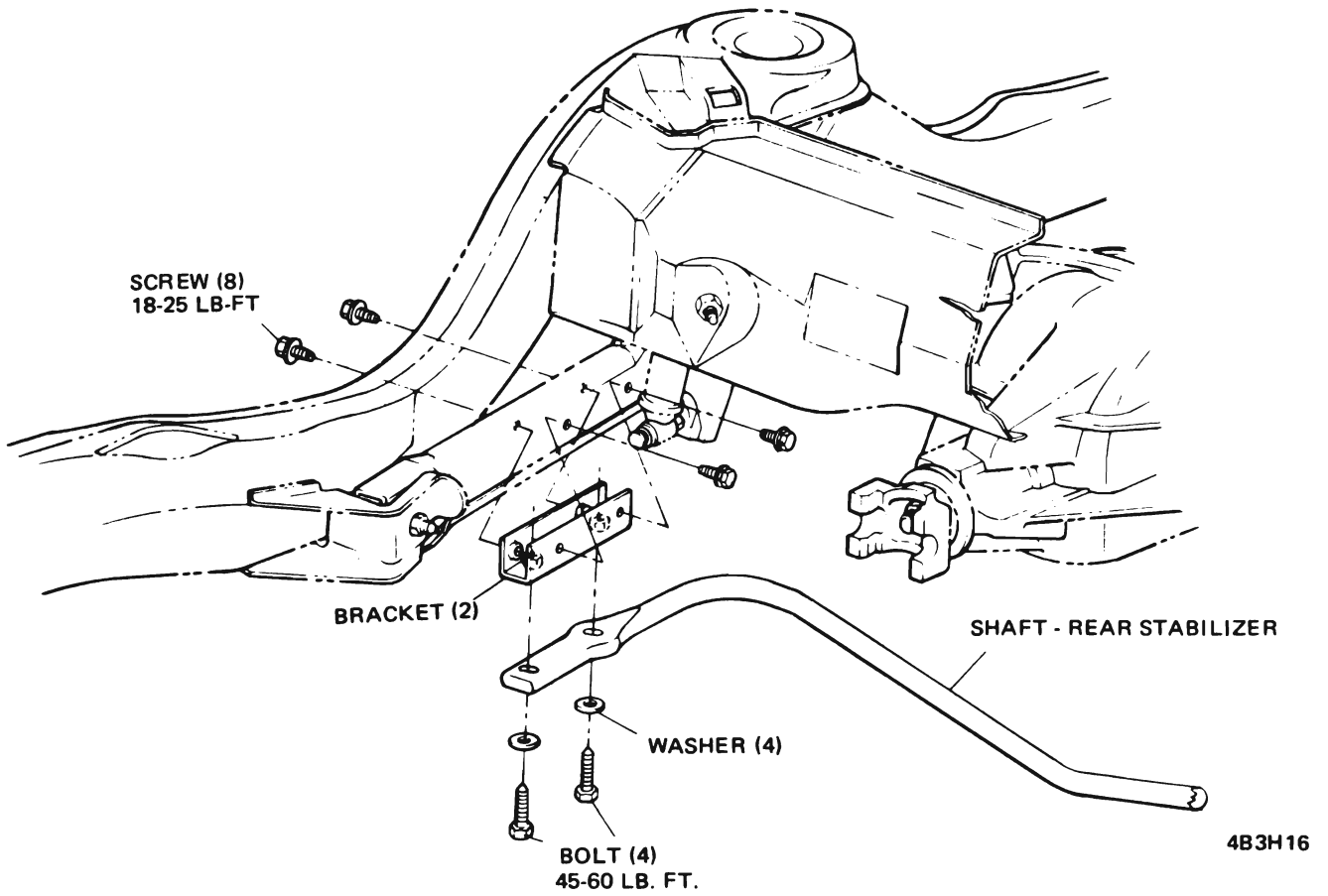
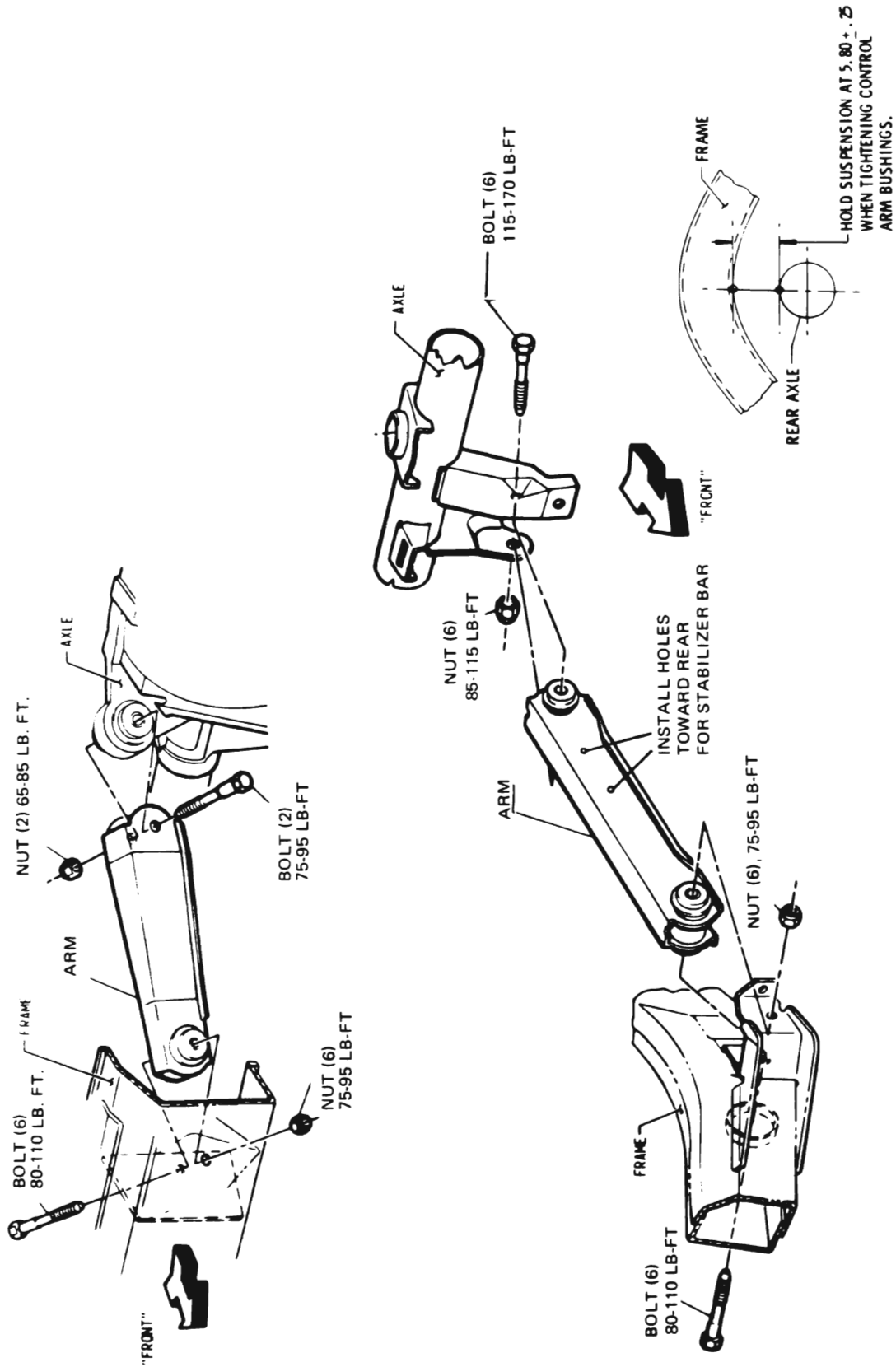
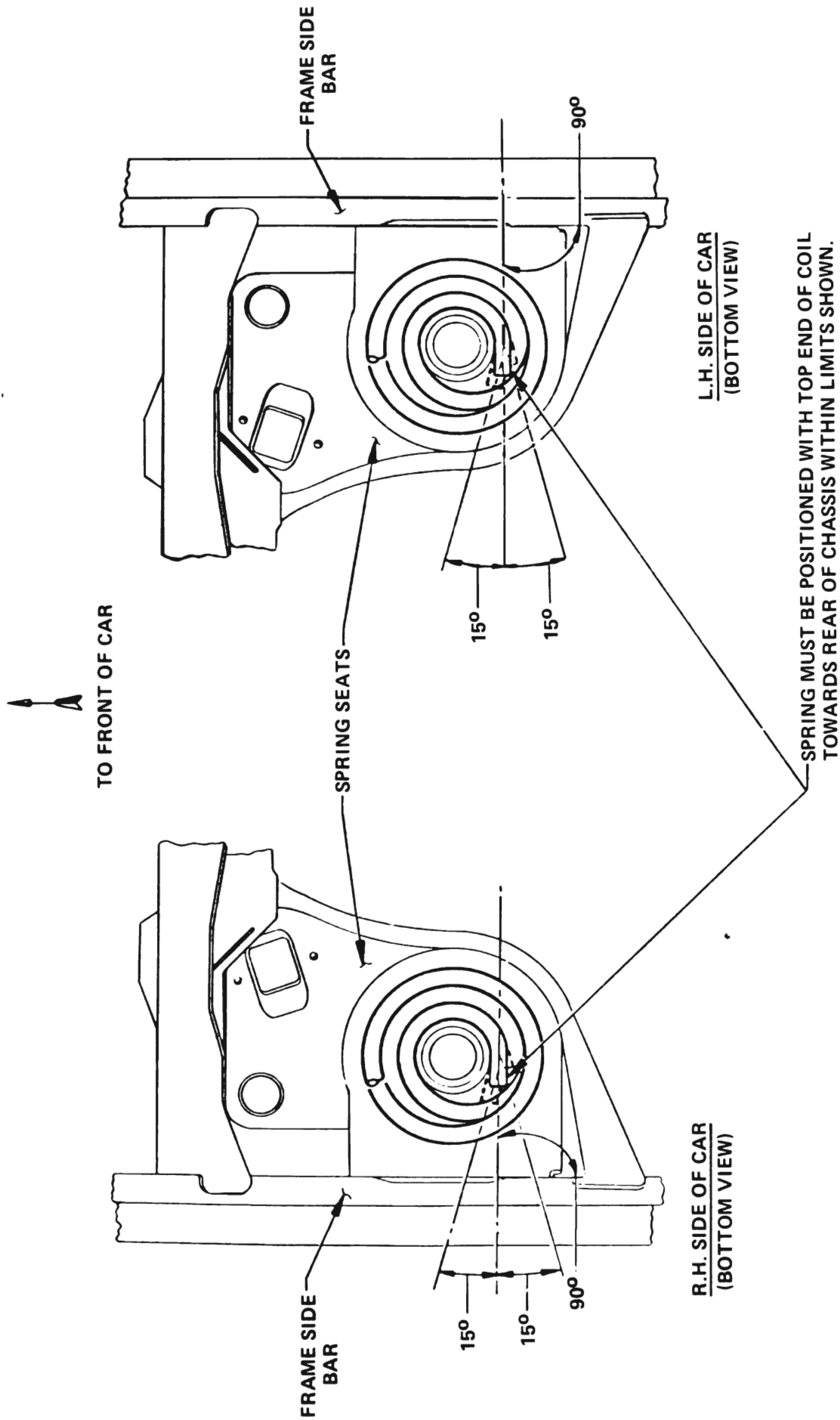

Figure 3H-16 A Series Stabilizer Bar



483H17

Figure 3H-17 B-C-E Series Rear Control Arms (Less Wagons)



3H-11

Figure 3H-18 Rear Spring Orientation B-C-E Series (Less Wagon)

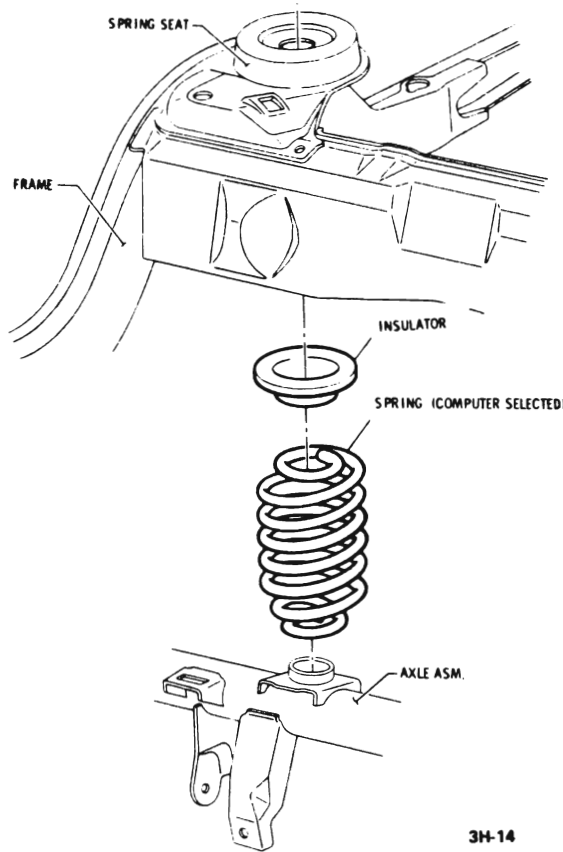

Figure 3H-19 B-C-E Series Rear Spring (Less Wagon)

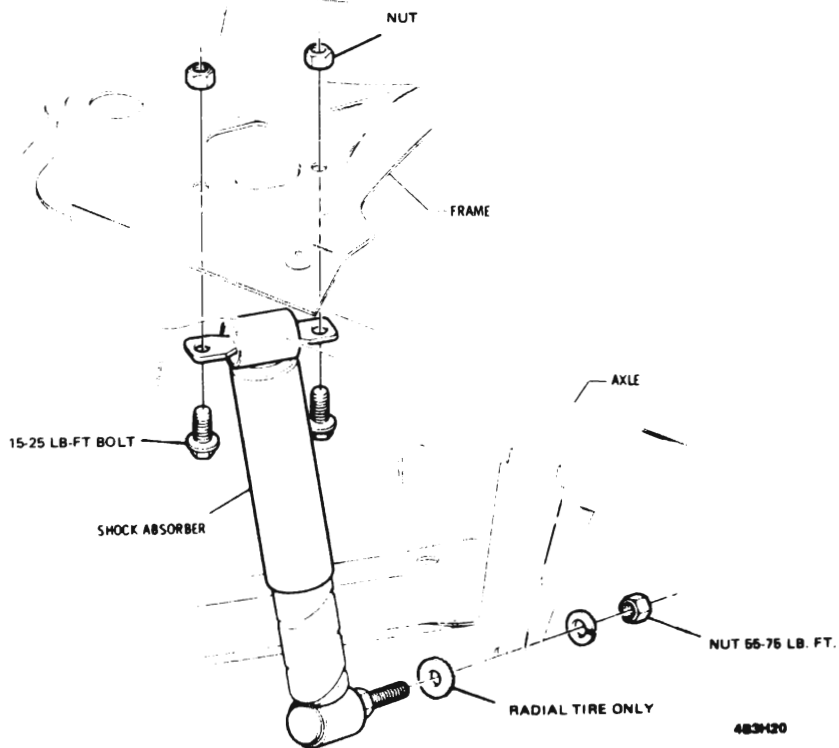

Figure 3H-20 B-C-E Series Rear Shock Mounting (Less Wagon)

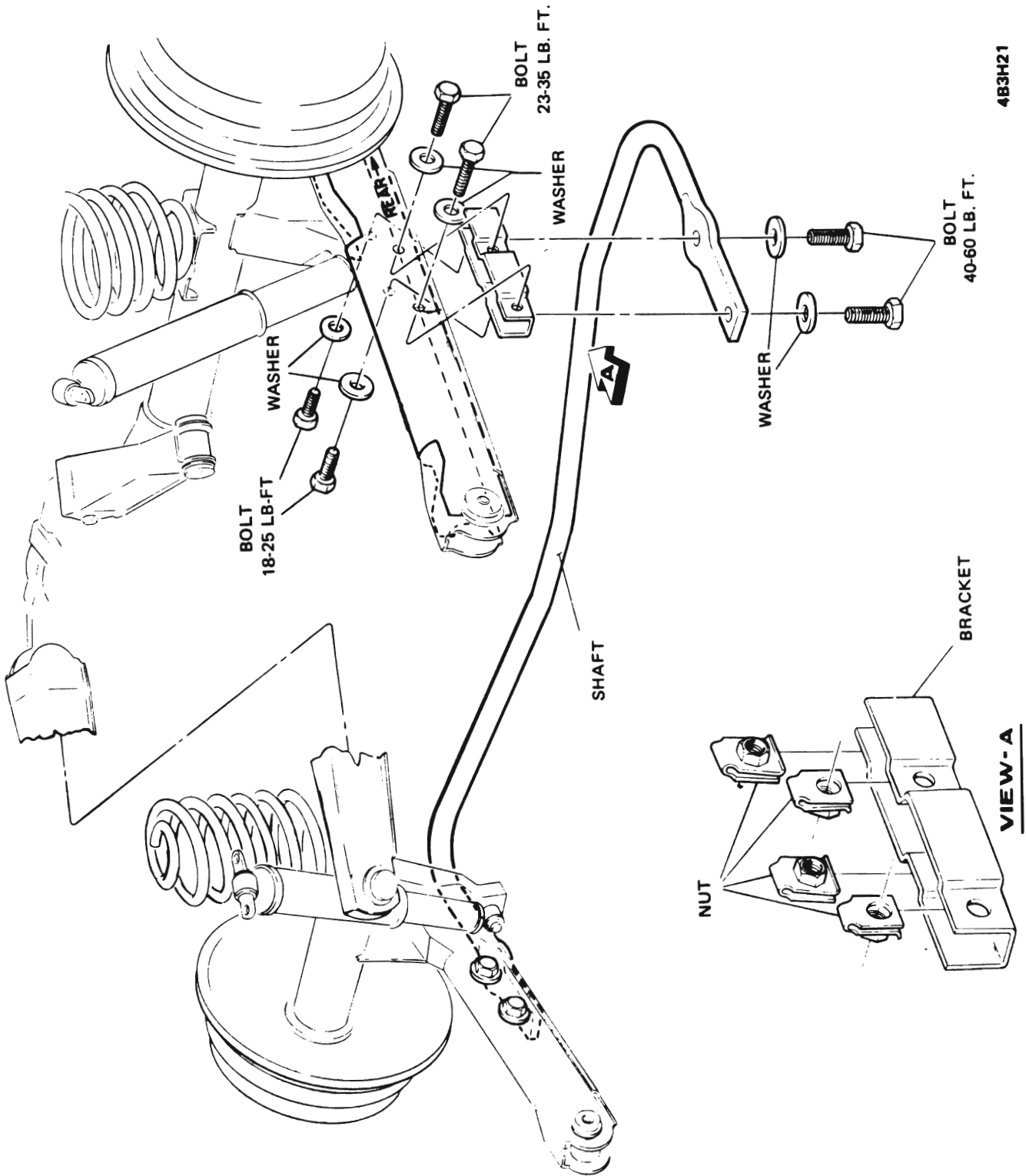

Figure 3H-21 B-E Series Stabilizer Bar

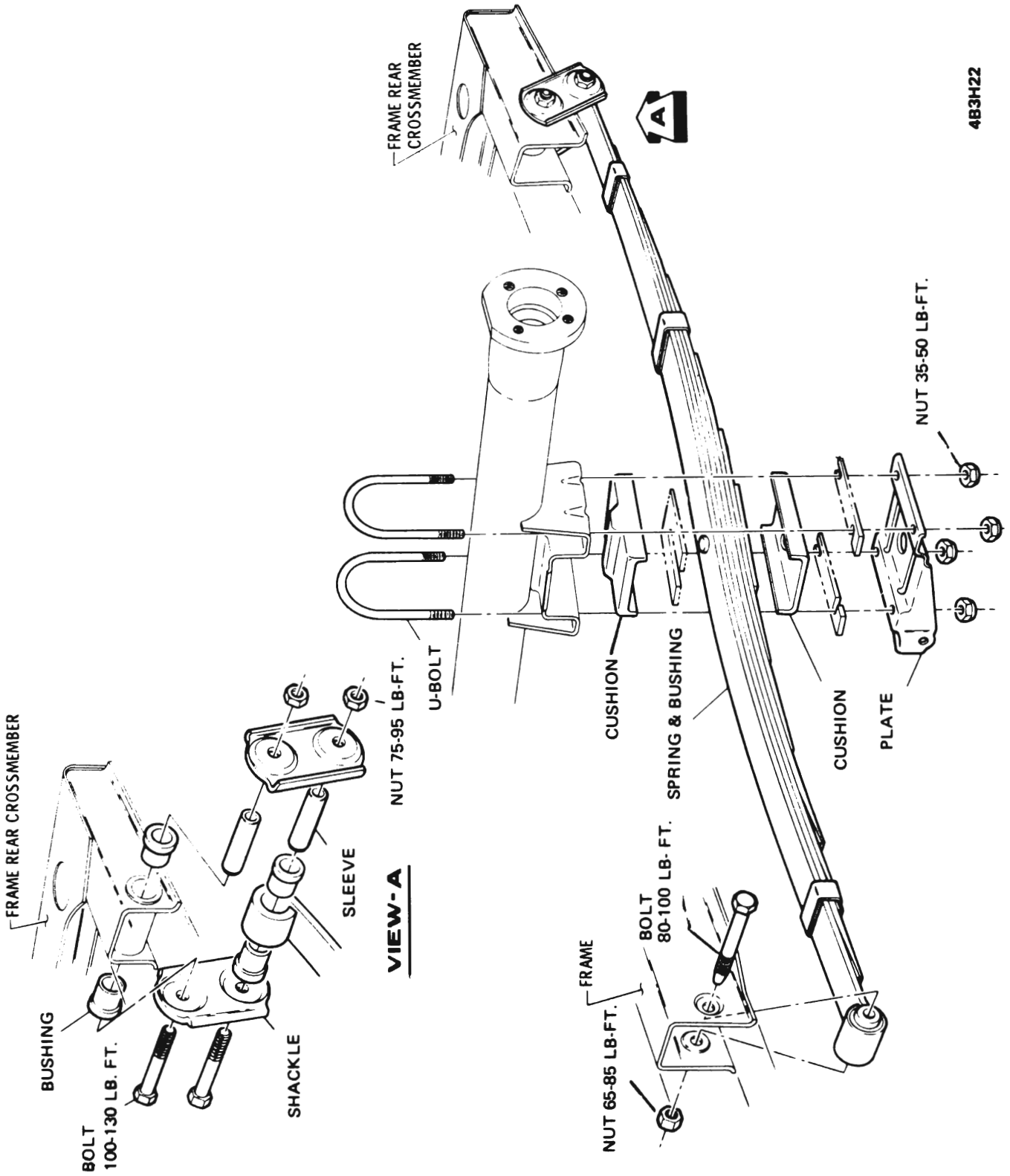

Figure 3H-22 B Wagon Rear Springs

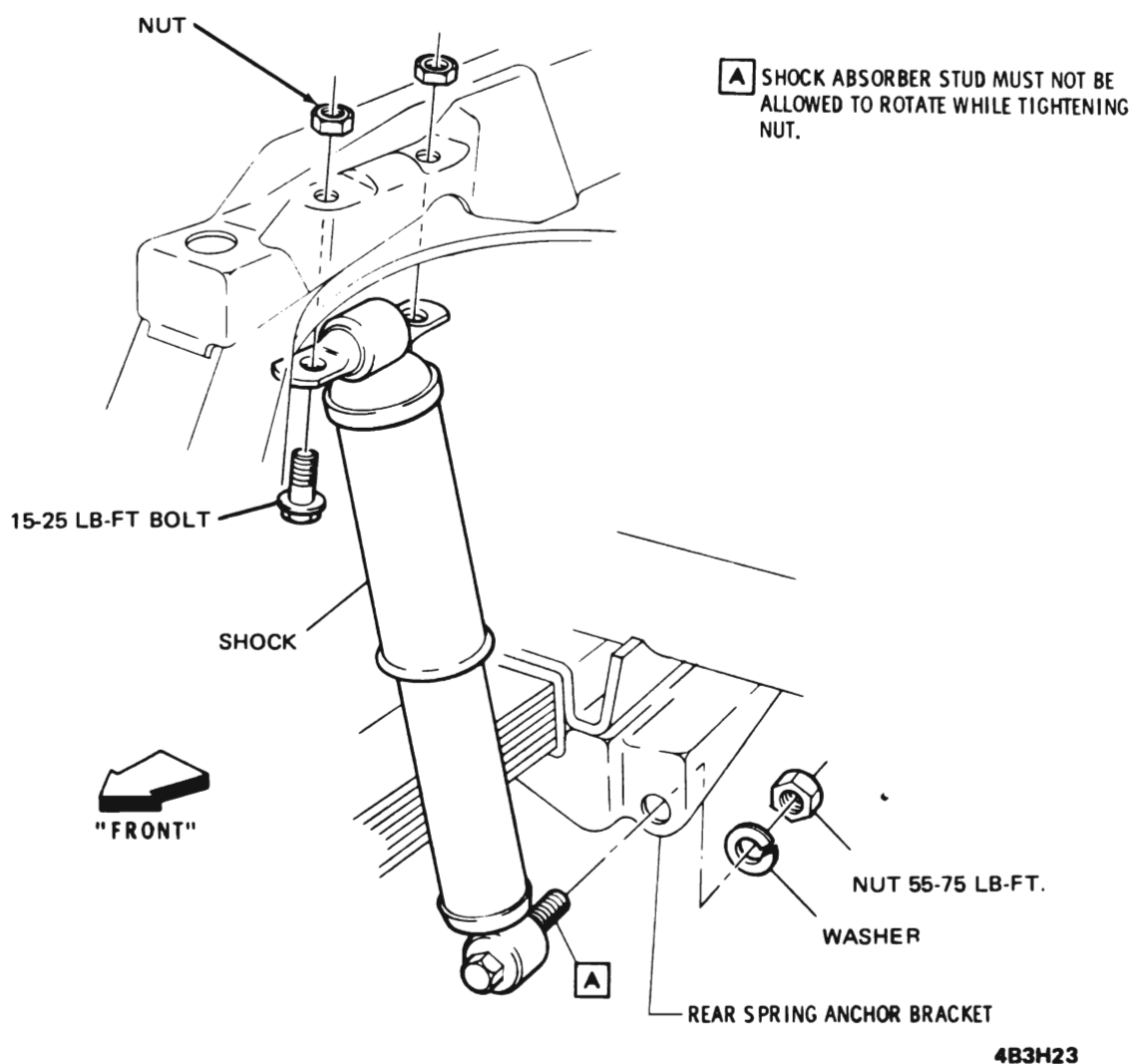

Figure 3H-23 B Wagon Rear Shock Mounting